

I/C CABLE 4c x 10 sqmm AL. COND.
Armed XLPE from MAIN L.T PANEL

NO. OF PDB = 01

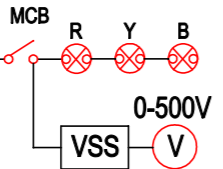

TPN MCB
50 A ; 10 KA
Curve 'C'

TPN AL. BUSBAR - 100 A

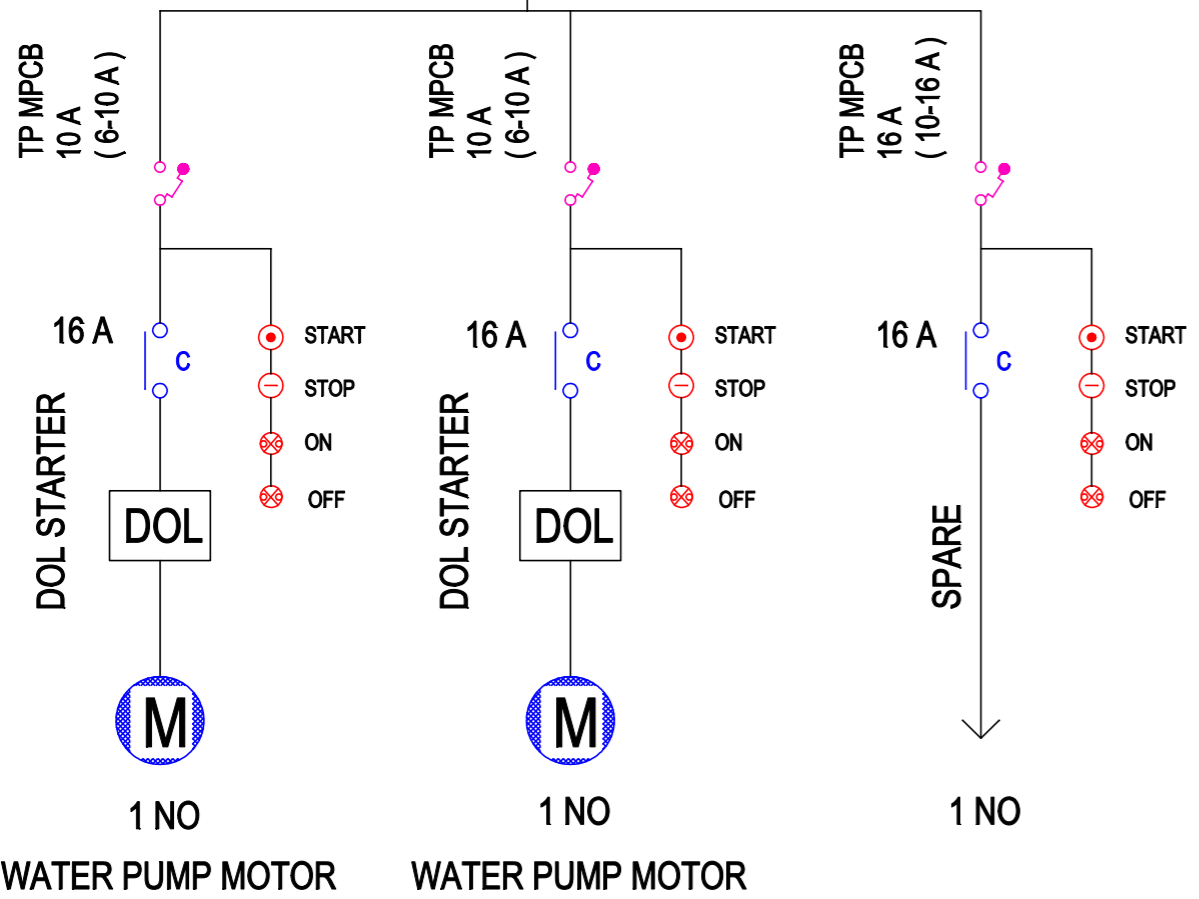

PDB FOR WATER PUMP DOMESTIC WATER SUPPLY

I/C CABLE 4c x 16 sqmm AL. COND.
Armed XLPE from MAIN L.T PANEL

NO. OF PDB = 01

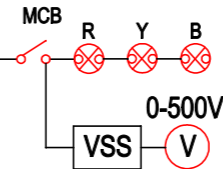

TPN MCCB
63 A ; 10 KA
Curve 'C'

TPN AL. BUSBAR - 100 A

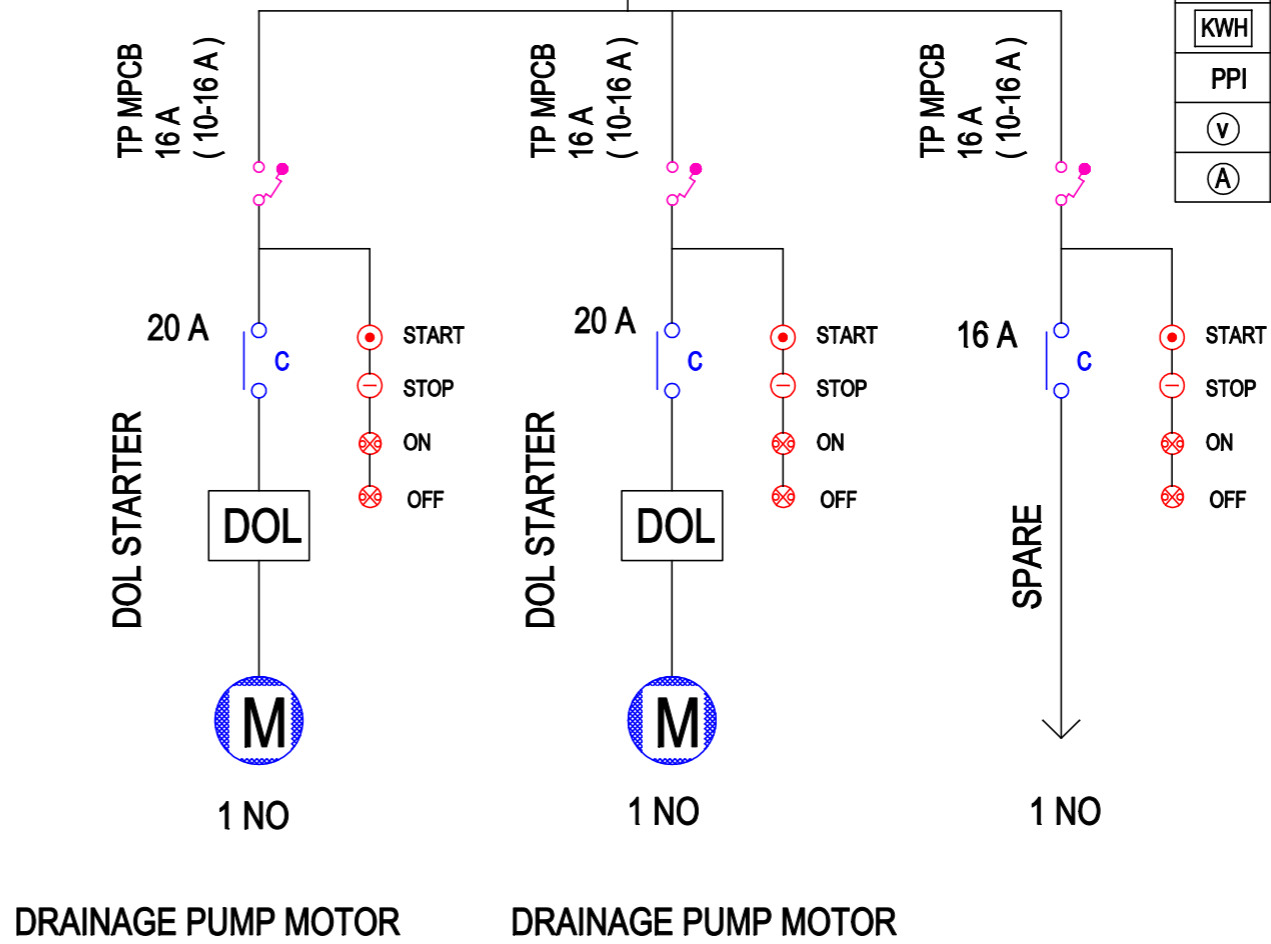

PDB FOR WATER DRAINAGE PUMP

LEGEND		SAFETY / INDICATION DEVICES
	(MCB ,SP/TP/4P)	MINITURE CIRCUIT BREAKER
	(MCCB ,TPN/4P)	MOULDED CASE CIRCUIT BREAKER
		INDICATION LAMP
	DG	SET
	HT/LT	TRANSFORMER
	C	CONTACTOR ,TP/4P
	(ACB ,TPN/4P)	AIR CIRCUIT BREAKER
	(TP/TPN)	MOTOR PROTECTION CIRCUIT BREAKER WITH BUILT IN THERMAL OIL RELEASE VARIABLE
	11KV GO	SWITCH WITH DROP OUT FUSES
	MF	MULTI FUNCTION METER
		AUTO MANUAL SWITCH
	RCCB/ELCB	(-TPN/DP)
		START / STOP PUSH BUTTON
	M	MOTOR - KW
	KWH	DUAL ENERGY METER (TO READ SEB / DG POWER CONSUMPTION)
	PPI	PER PHASE ISOLATION WITH SEPARATE 'N' FOR EACH PHASE
	V	VOLTMETER WITH SELECTOR SWITCH
	A	AMMETER WITH SELECTOR SWITCH

PROJECT:
UNDER GROUND PARKING FOR IMPROVEMENT TRUST AMRITSAR

SHEET TITLE:
PDB FOR WATER PUMP DOMESTIC WATER SUPPLY & PDB FOR WATER DRAINAGE PUMP

DRG.NO. SLD-9
DATE: 02.05.2013
REVISION:
ENGINEER:

BALWINDER SINGH ENGG. CONSULTANTS
OFFICE:24/8,INDUSTRIAL AREA,PHASE-II,CHANDIGARH
BRANCH OFFICE:W2/313,TEACHERS COLONY,HIRA MAHAL,NABHA.
PHONE NO.9872455534,9501105681

