

**BEAUTIFICATION OF  
DURGIANA MANDIR COMPLEX  
AMRITSAR  
(PROPOSED PARKING )**

**GENERAL NOTES:**

1. The contractor/site engineer is to verify and relate all dimensions on site before execution of work. Change, if any is brought to the notice of architect immediately.
2. All dimension are to be read and not to be scaled.
3. All architectural and other drawings must be co-related by the contractor before execution of work.
4. Entire construction work is to be executed as per P.W.D. Specifications, B.I.S. Specifications and Specifications of each item as per approved in the Detail Estimate.

OWNER :

ARCHITECT :

VIVEK SUD  
(ARCHITECT)

DRAWING TITLE

**JOINERY DETAIL  
UPPER & LOWER BASEMENT**

DRAWING NO.

DET - 03

DRAWN BY

SEEMA

PROJ.NO.

0967

CHKD. BY

SHARDA PAL

SCALE

1/2" - 1'-0"

DATE

21.06.2013

**ARCHITECTS CONSORTIUM**

ARCHITECTS, PLANNERS, ENGINEERS,  
INTERIOR & INDUSTRIAL DESIGNERS  
S.C.O - 42, PHASE-3B2, MOHALI. (Pb.).  
☎ - 0172-5093132; ☎ - 0172-4643132;  
📠 - 98154 43132.  
E-mail - info@sudvivek.com  
Web site :- www.sudvivek.com

© COPYRIGHT

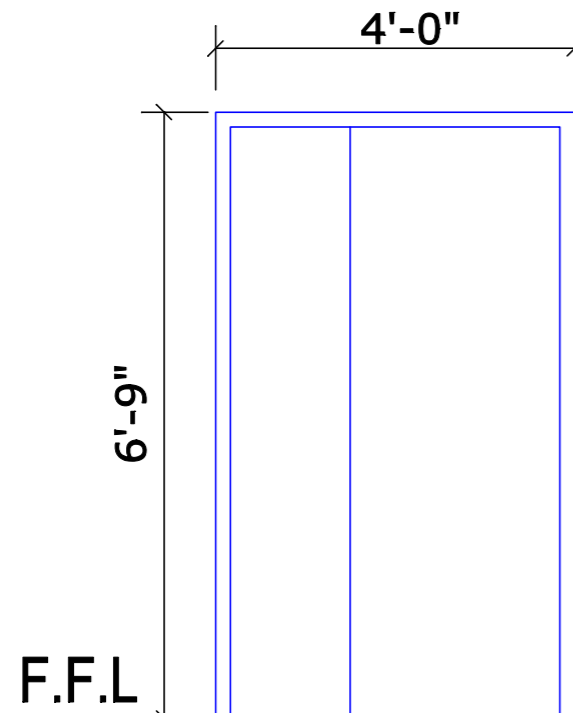

**D = 4'-0" X 6'-9"  
STAIR HALL**

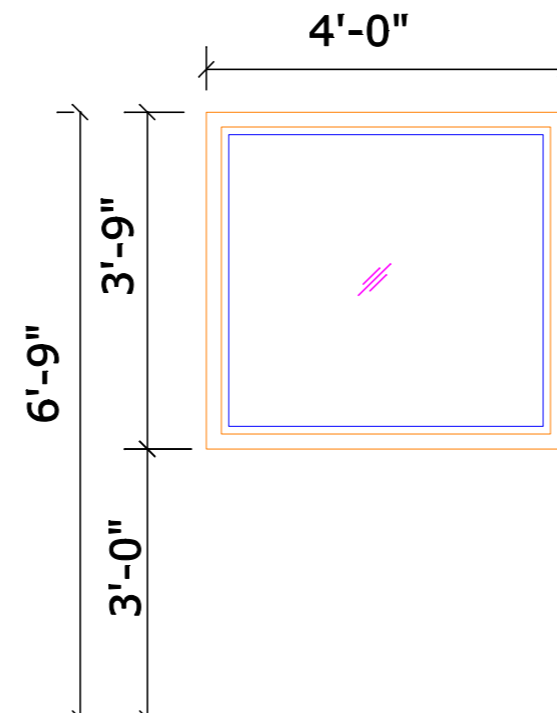

**W1 = 4'-0" X 3'-9"**

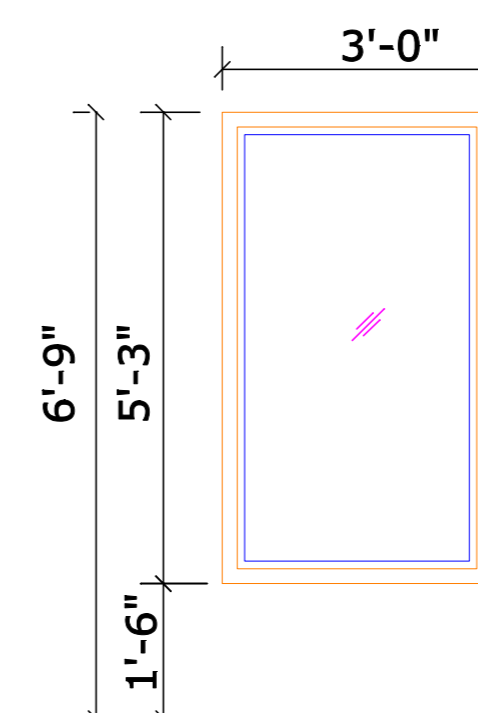

**W2 = 3'-0" X 5'-3"**

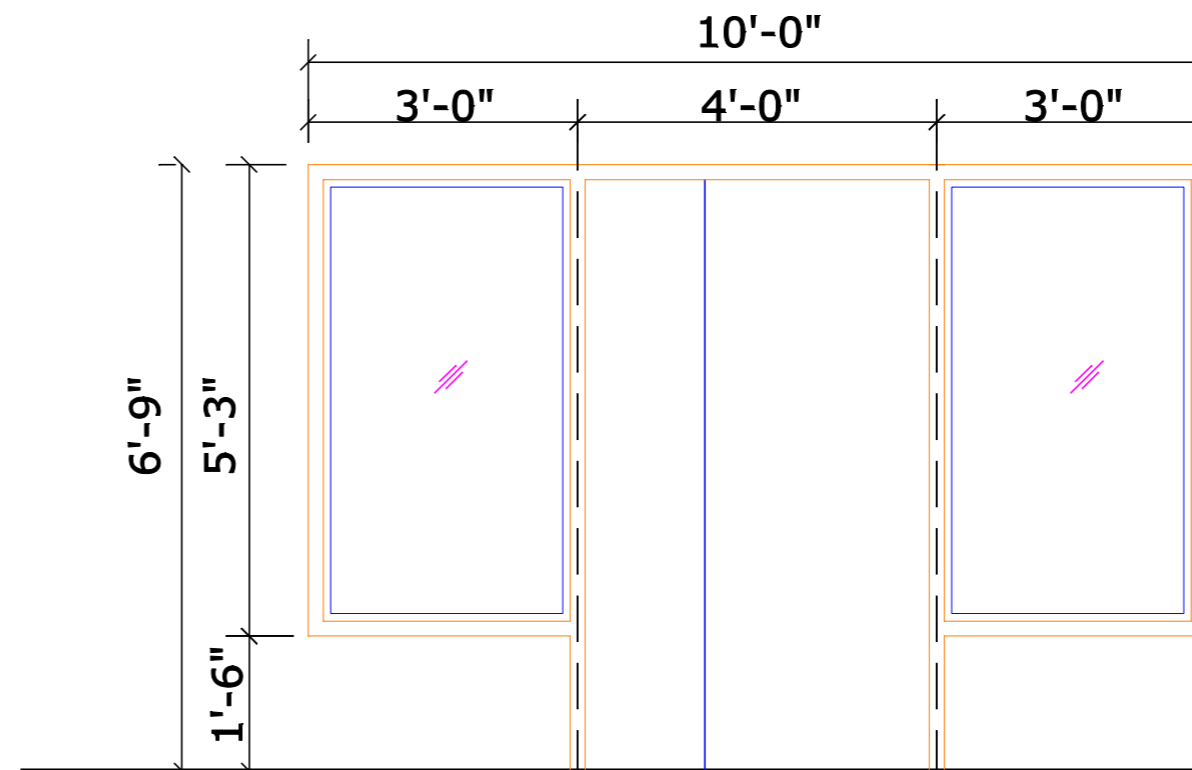

**D = 4'-0" X 6'-9"  
W2 = 3'-0" X 5'-3"  
STAIR HALL**

**SCHEDULE OF DOORS & WINDOWS**

| SR. NO. | TYPE | NOS. | MASONRY OPENING |        |       |       |
|---------|------|------|-----------------|--------|-------|-------|
|         |      |      | WIDTH           | HEIGHT | CILL  | TOP   |
| 1       | D    |      | 4'-0"           | 6'-9"  | ---   | 6'-9" |
| 2       |      |      |                 |        |       |       |
| 3       | W1   |      | 4'-0"           | 3'-9"  | 3'-0" | 6'-9" |
| 4       | W2   |      | 3'-0"           | 5'-3"  | 1'-6" | 6'-9" |
| 5       |      |      |                 |        |       |       |

**Note:-**

1. Entire construction work is to be executed as per P.W.D. Specifications , B.I.S. Specifications and Specifications of each item as per approved in the Detail Estimate.
2. Basement Concreting , Water Proofing Treatment & Treatment to construction joints should be properly followed as per Specifications given in the Detail Estimate.