

Individual Spread Footing

U H Varyani

H S Rai

January 26, 2016

Contents

12 Individual Spread Footing	11
12.1 Introduction	11
12.2 Types of Individual Footings	11
12.3 Design for Perimeter Shear	13
12.4 Design for Moment and Beam Shear	14
12.5 Development Length of Bars	17
12.6 Selection of Type of Footings	17
12.7 Examples	18
12.8 Conclusion	23

List of Figures

12.1	Types of individual spread footing.	12
12.2	Perimeter shear for square footing.	13
12.3	Critical sections for bending moment and beam shear in footings.	15
12.4	Development length of footing bars.	17

List of Charts

12.1 Effective Depth (d) of Square Individual Footings for Safety of perimeter shear 22

List of Tables

12.1 Depth of Footing for Safe Bearing Capacity 23

Chapter 12

Individual Spread Footing

12.1 Introduction

Clause 34 of the *IS456:2000* gives the provisions governing the design of reinforced concrete footings. These provisions are similar to those given by the ACI Committee 318. The design of footings in accordance with *IS456:2000* differs from that by the *IS456:1964* in the following aspects.

- I Perimeter shear stress must not exceed the allowable value. This aspect was not given in the *IS456:1964*. But it is similar to the familiar concept of punching shear stress.
- II Bond-stress-criterion was given in the *IS456:1964*, but it is omitted in the *IS456:2000*. Instead, development length of footing bars is required to be checked at the sections where bending moment is critical.
- III 25% excess pressure on edge of footing was allowed by the *IS456:1964* when a footing is eccentrically loaded. This concession is withdrawn by the *IS456:2000*, thereby adding to the cost of eccentrically loaded footings.

The *IS456:2000* requires footings to be designed for the following limit states.

- (a) Perimeter shear
- (b) Bending moment
- (c) Beam shear
- (d) Development length of footing bars
- (e) Development length of column bars

12.2 Types of Individual Footings

Individual spread footings can be either square or rectangular in plan, the area of a rectangular footing with sides A and B being given by,

$$A \times B = \frac{P}{p} \quad (12.1)$$

where P is the column load in kN and p denotes the net allowable soil pressure in kN/m^2 . In this development, self-weight of footing may not be considered. This involves only a small error in that, the weight of the concrete of footing is assumed here to be approximately equal to the weight of the earth displaced by it. Further, it is assumed here that the soil pressure under the footing is uniform. This is a reasonable assumption as discussed elsewhere. Various types of individual spread footings are shown in Fig.12.1. With the area of footing known from Equation 12.1, dimensions A and B are easily finalise. The only dimension of footing which remains to be known is the depth (D) of the footing. A common way of design of footing is to assume D , rather generously, with a view to reduce steel area as well as to help provide fixity to the column base, in order to be close to the assumptions made in the frame analysis of superstructure.

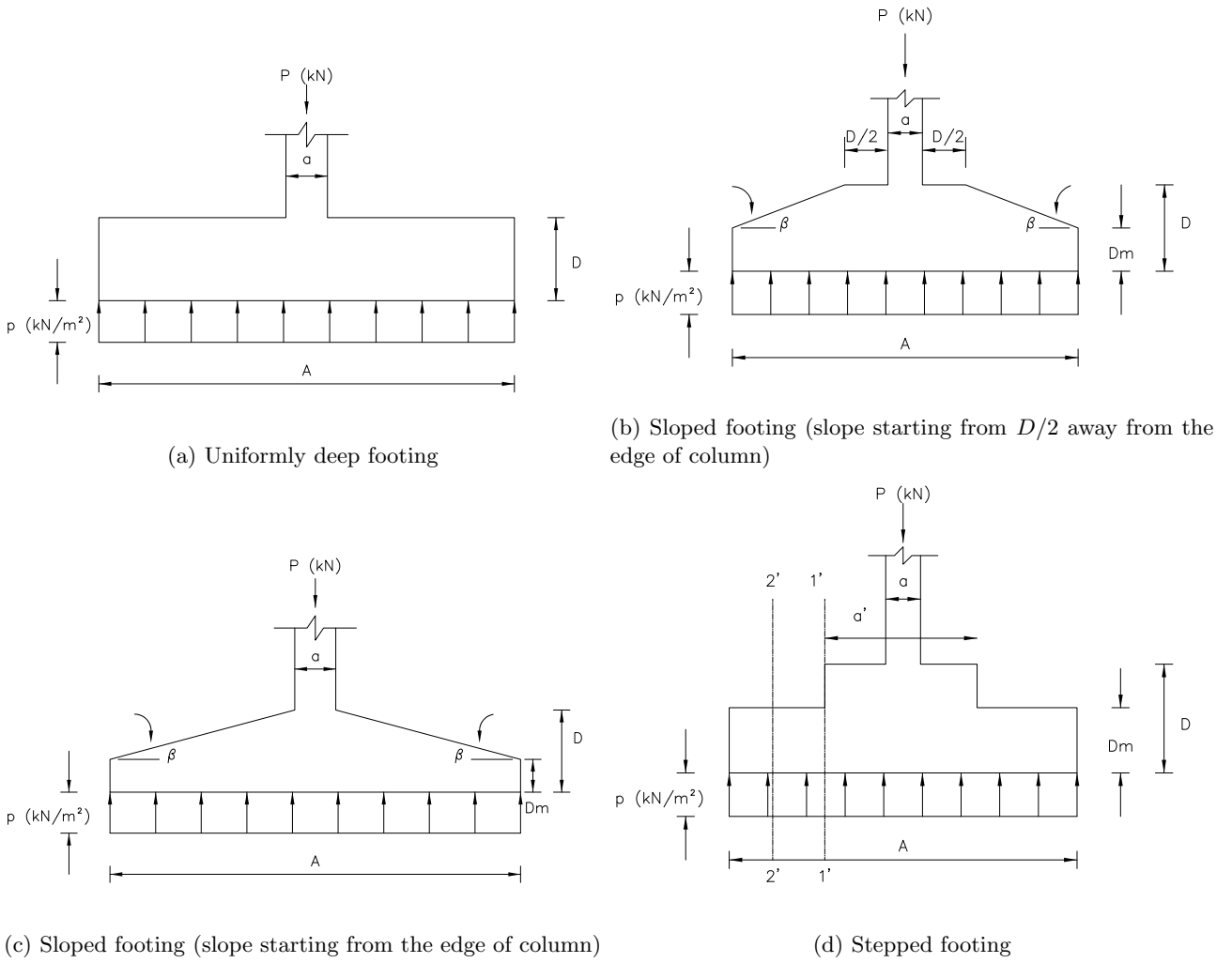
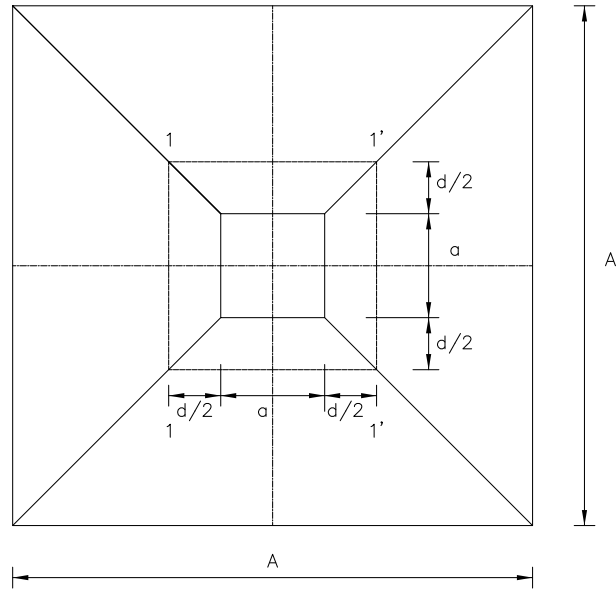
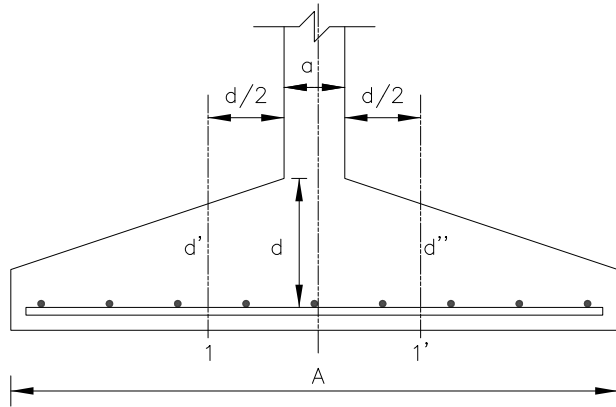

Figure 12.1: Types of individual spread footing.



(a) Critical perimeter 1-1-1-1 in plan for perimeter shear



(b) Section of sloped footing showing reduced depth d' for perimeter shear

Figure 12.2: Perimeter shear for square footing.

12.3 Design for Perimeter Shear

Depth of footing is fixed from the consideration of perimeter shear stress which depends on concrete quality, being independent of types of reinforce steel. For a square footing of uniform depth with a square column of side a (Fig.12.2a), perimeter shear stress τ_v is given by

$$\tau_v = \frac{V_u}{b_0 \times d} = \frac{1.5 \times S_p}{4(a + d) \times d} \quad (12.2)$$

where

$$S_p = P - p \times (a + d)^2 \quad (12.3)$$

and b_0 = Perimeter of critical closed section.

The allowable perimeter shear stress τ_a (clause 31.6.3 of the *IS456:2000*) is given by,

$$\tau_a = k_s \cdot \tau_c = k_s \times 0.25 \sqrt{f_{ck}} \quad (12.4)$$

where, f_{ck} is to be put in N/mm^2 .

$k_s = 1.0$ for square columns and also for rectangular with aspect ratio $\left(\frac{b}{a}\right) \leq 2.0$. For the condition $\tau_v = \tau_a$, Equation(12.2) and (12.4) give,

$$-\frac{\frac{a^2}{A^2} + \frac{2ad}{A^2} + \frac{d^2}{A^2} - 1}{\frac{ad}{A^2} + \frac{d^2}{A^2}} = \frac{0.0670 \alpha \sqrt{fck}}{p} = k(\text{say}) \quad (12.5)$$

For a square sloped footing with a square column of side a (Fig.12.2b),

$$\tau_v = \frac{V_u}{b_0 \times d''} = \frac{1.5 \times S_p}{4(a+d) \times d''} \quad (12.6)$$

Assuming $d'' = \alpha.d$, the condition $\tau_v = \tau_a$ gives,

$$-\frac{\frac{a^2}{A^2} + \frac{2ad}{A^2} + \frac{d^2}{A^2} - 1}{\frac{ad}{A^2} + \frac{d^2}{A^2}} = \frac{0.0670 \alpha \sqrt{fck}}{p} = k \quad (12.7)$$

$\alpha = 1.0$ for footings of Types (a), (b) and (d) (Fig.12.1), while $\alpha < 1.0$ for sloped footings of Type (c). The overall depth of footing is given by,

$$D = c + d + \phi \quad (12.8)$$

Here, d is regarded as an average value for either steel layer. For sloped footings (Fig.12.2b), simple geometry gives,

$$\alpha = \frac{d''}{d} = \frac{D_m}{d} + \frac{D - D_m}{d} \cdot \frac{\left(1 - \frac{a}{A} - \frac{d}{A}\right)}{\left(1 - \frac{a}{A}\right)} = \frac{(c + \phi)}{d} \quad (12.9)$$

Chart12.1 is developed on the basis of Equation(12.5) and (12.7) and it applies to both uniformly deep and sloped square footings. It can also be used for rectangular footings with rectangular columns by using average values of a and A , provided an equal overhang is left on all sides of column, which requires,

$$-a + b = -A + B \quad (12.10)$$

Solution of numerical examples gives an idea that it is possible to develop thumb rules for fixing depth of footings. It may be noted that there is no dire need of exactness in fixing the value of depth of footing, only it should be more than adequate for the actions imposed on a footing. Table12.1, based on Equation(12.5), is developed for footings of Types (a) and (b) (Fig.12.1).It gives values of D/A for various practicable values of p . It is seen that, for safety in beam shear, these values are to be increased by 10% in case of steel types $Fe 415$ and $Fe 500$. For sloped and stepped footings (Types c and d), the depth of footing given by Table12.1 may be increased by 20%. The depth at the free end of a footing may be restricted to 150 mm, which is the minimum prescribed by the *IS456:2000* for spread footings.

12.4 Design for Moment and Beam Shear

Section 1-1 in Fig.12.3 is the critical section for bending moment. The bending moment for full width B is given by,

$$M_{1-1} = \frac{1}{8} (A - a) B p \quad (12.11)$$

For footings of uniform depth and also stepped footings, the concrete compression zone is rectangular and charts of Chapter 2 are used to calculate the required area of steel. But for sloped footings, the concrete compression zone is of a trapezoidal shape and Chart4.1 of Chapter 4 is to be used for finding steel area. Chart4.1 can be used for both uniformly deep ($\gamma = 0$) and sloped footings. The calculated steel area should not be less than the specied minimum steel area (Table11.4 of Chapter 11) for spread footings which may be regarded as slabs for this purpose.

Section 2-2 in Fig.12.3 is the critical section for beam shear. The shear force and moment at section 2' - 2' for the full width of footing is given by,

$$S_{2-2} = \frac{1}{2} (A - a - 2d) B p \quad (12.12)$$

$$M_{2-2} = \frac{1}{8} (A - a - 2d)^2 B p \quad (12.13)$$

Beam shear stress τ_v for footings of uniform depth and stepped footings is given by,

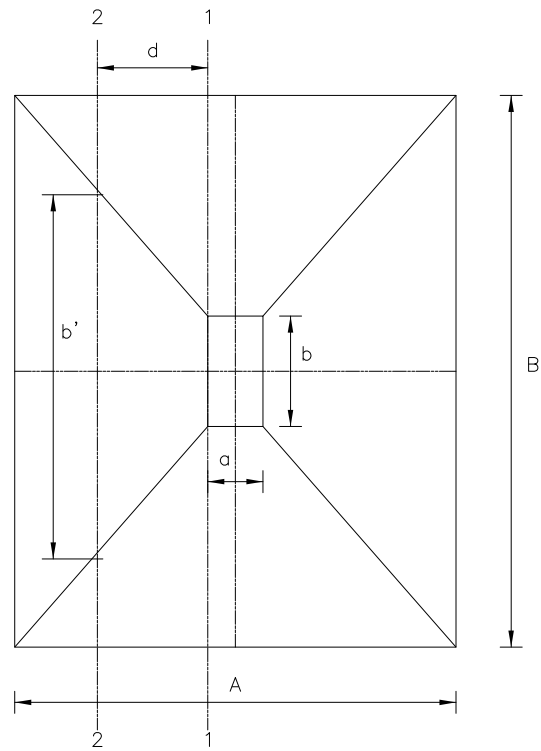

(a) Plan of sloped footing

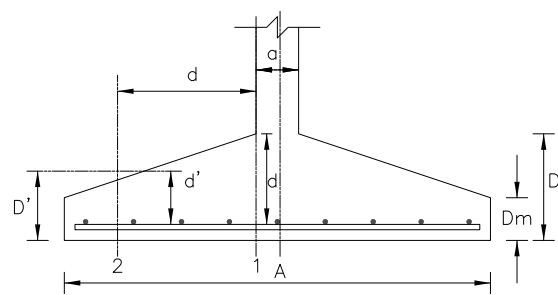

(b) Section of sloped footing

Figure 12.3: Critical sections for bending moment and beam shear in footings.

$$\tau_v = \frac{V_u}{bd} = \frac{1.5 \times S_{2-2}}{bd} \quad (12.14)$$

where,

$$\begin{aligned} b &= B \text{ for uniformly deep footings,} \\ &= a \text{ for stepped footing (Fig.12.1d)} \end{aligned}$$

For sloped footings, clause 40.1.1 of the *IS456:2000* gives, (-ve sign applies here),

$$\tau_v = \frac{V_u}{b'd'} - \frac{M_u}{b'd'^2} \cdot \tan \beta \quad (12.15)$$

where b' , d' are shown in Fig.12.3a and Fig.12.3b and M_u is the ultimate moment at section 2-2.

$$D' = D_m + \frac{(D - D_m) \left(\frac{a}{A} + \frac{2d}{A} - 1 \right)}{\frac{a}{A} - 1} \quad (12.16)$$

$$d' = D' - (c + \phi) \quad (12.17)$$

$$b' = b + \frac{2(B - b)d}{A - a} \beta \quad (12.18)$$

For Type (c), Fig.12.1c gives,

$$\tan(\beta) = \frac{2(D - D_m)}{A - a} \quad (12.19)$$

For Type (b), Fig.12.1b gives,

$$\tan(\beta) = \frac{2(D - D_m)}{A - D - a} \quad (12.20)$$

The calculated value of τ_v must not exceed the allowable stress τ_a , as shear reinforcement is just not provided in individual footings for reasons of economy, the same as in solid slabs. The allowable stress in concrete solid slabs τ_a is given by,

$$\tau_a = k\tau_c \quad (12.21)$$

τ_c is given by Table19 of the *IS456:2000* depending on the steel area provided for moment at the critical section 2-2 (the minimum value of τ_c is assumed for $p_t \leq 0.15$ in Table19 and

$$\begin{aligned} k &= 1.0 \text{ for } D \geq 300mm \\ &= 1.1 \text{ for } D = 250mm \\ &= 1.2 \text{ for } D = 200mm \\ &= 1.25 \text{ for } D = 175mm \\ &= 1.30 \text{ for } D \leq 150mm \end{aligned}$$

Normally, depth of footing given for perimeter shear (Chart12.1) is more than adequate to satisfy the requirements of beam shear. But when steel type *Fe 415* and *Fe 500* are used as reinforcement beam shear may govern the depth of footing. For stepped footings, additional checks for moment and beam shear are required to be made for the portion of the footing of depth D_m (Fig.12.1d). When section 1' - 1' is the critical section for moment and section 2' - 2' is that for beam shear (Fig.12.1d), expressions for moment and shear are given as,

$$M_{1'-1'} = p \cdot B \cdot \frac{(A - a')^2}{B} \quad (12.22)$$

$$S_{2'-2'} = p \cdot B \left[\frac{(A - a')^2}{B} - d_m \right] \quad (12.23)$$

For finding steel area, Chart4.1 (with $\gamma = 0$), may be used, as the concrete compression zone is of a rectangular shape of width equal to B . Shear stress τ_v is given by,

$$\tau_v = \frac{V_v}{bd} = \frac{1.5S_{2-2}}{B \cdot d_m} \quad (12.24)$$

and it must not exceed τ_a given by Equation(12.21), failing which depth D_m should be suitably increased. Normally $D_m = 0.30 D$ to $0.50 D$ is kept in stepped footings and perimeter shear stress can be checked to be safe by using first principles.

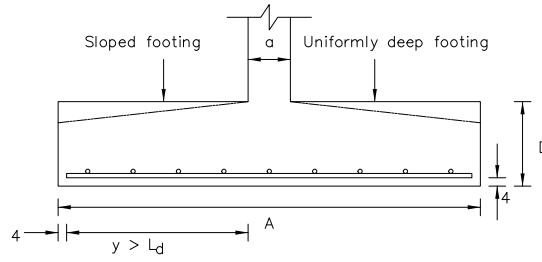

(a) Section of uniformaly and sloped footing

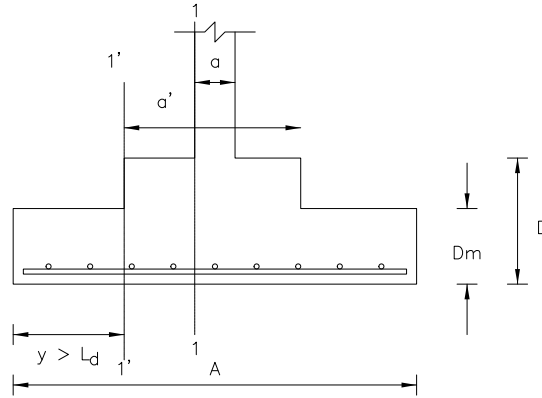

(b) Section of stepped footing

Figure 12.4: Development length of footing bars.

12.5 Development Length of Bars

Column dowel bars should extend into footings for a distance equal to the development length (Table 11.3 of Chapter 11) of column bars in compression (or in tension when moment in column is large). With the clause 26.2.2.2 of the *IS456:2000*, column bars can always be adequately anchored in the footing, whatever be the depth of footing.

For development length of footing bars, there should be adequate bar length available (y), either straight or bent-up or both measured from the face of column. Referring to Fig. 12.4a, for sloped or uniformly deep footings,

$$y = \frac{1}{2} A - \frac{1}{2} a - 4 > L_d(\text{tension}) \quad (12.25)$$

where 40 mm is taken as clear cover over ends of bars in footings. If Equation 12.25 is not satisfied, there are two ways to tackle this problem :

1. bend bars up, as shown dotted in Fig. 12.4a
2. choose smaller diameter for bars.

For stepped footings Fig. 12.4b, the available straight length of bars beyond the critical section 1' - 1' is,

$$y' = \frac{(A - a')}{2} - 4 > L_d(\text{tension}) \quad (12.26)$$

Normally, full steel area required at section 11 is provided throughout and the steel strength σ_s at section 1 - 1 may be less than its maximum value of $0.87 f_y$. The value of L_d (tension) should be calculated for the appropriate value of σ_s .

12.6 Selection of Type of Footings

Footings of uniform depth (Type a), though commonly used in practice for reasons of ease in design and construction, are the costliest. These consume more concrete quantity (about 25% to 45%) than that by sloped footings. This type is suitable only for small footings with overall depth being restricted to, say, 300 mm.

For footings of intermediate size, sloped footings with slope starting from $\frac{D}{2}$ away from the edge of column (Type *b*), are quite suitable. This type is quite economical giving concrete and steel quantities quite reasonable in comparison with other types. This type is easy to design as well as to execute. This type is recommended for most individual footings encountered in buildings with overall depth greater than 300 mm. The depth at the free end of footing may be kept at 150 mm, the specified minimum given by the *IS456:2000*. The depth (*D*) of this type of footing is kept the same as that for footings of uniform depth.

For large-sized footings, sloped footings with the slope starting from the edge of column (Type *c*) or stepped footings (Type *d*) are preferred to other types, as these give the least quantities for concrete and steel consumption. The stepped footings give the least steel quantity, while the sloped footings (Type *c*), give the least concrete quantity. The depth for these types of footings works out to be about 20% more than that for footings of uniform depth. Stepped footings are a little cumbersome in construction, while the sloped footings are easier in execution, albeit a little more labour-intensive than the footings of uniform depth.

12.7 Examples

Example 12.1. Square footing of Uniform Depth (Type *a*).

Given:

$$\begin{aligned} P &= 1000kN \\ p &= 200.kN/m^2 \\ a &= 400mm \\ f_{ck} &= 15N/mm^2 \\ f_y &= 415N/mm^2 \end{aligned}$$

Required: Design the footing

Solution:

(i) **Dimensions of footing**

Equation12.1 gives,

$$\begin{aligned} A^2 &= \frac{P}{p} = 5.0053 \times 10^6 mm^2 \\ A &= 2236.mm \\ A &= 2250mm \end{aligned}$$

Provided 2250 × 2250 base and

$$p = 197.5kN/m^2$$

Table12.1 gives for $p = 0.00020$, and steel *Fe* 415,

$$D = 0.222 A = 500.mm$$

(ii) **Check for perimeter shear**

Chart12.1 gives for,

$$\begin{aligned} k &= \frac{670. \alpha \sqrt{f_{ck}}}{p} = 13.15 \\ \frac{a}{A} &= 0.178 \\ \frac{A}{d} &= 5.5 \\ d &= 410. \end{aligned}$$

Equation12.8 gives with $c = 40.mm$, $\phi = 12.$,

$$D = c + d + \phi = 464.0mm$$

$$D = 500.mm \text{ is safe}$$

(iii) **Design for moment** Equation 12.11 gives,

$$M_{1-1} = \frac{1}{8} (A - a)^2 B p = 190.1 \text{ kNm}$$

With rectangular compression zone, Chart (2.2) gives for,

$$d = D - c - \phi = 423.0 \text{ mm}$$

$$k = 0.04723$$

$$\mu = 0.047$$

$$A_{st} = \frac{1.15 A d f_{ck} \mu}{f_y} = 1878. \text{ mm}^2$$

$$\frac{A_{st}}{A} = 834.7 \text{ mm}^2 / \text{m}$$

Table 11.4 gives the minimum tension steel area in footings taken as slab,

$$A_{st}(\text{min}) = 1.2 D = 600. \text{ mm}^2 / \text{m}$$

$\phi 12/135$ c/c both ways provided giving an area = $837.3 \text{ mm}^2 / \text{m}$ which is exceeded by that provided.

(iv) **Design for beam shear**

Equation 12.12 gives,

$$S_{2-2} = \frac{1}{2} (A - a - 2d) A p = 223.1 \text{ kN}$$

Equation 12.14 gives

$$\tau_v = \frac{1.5 S_{22}}{A d} = 0.35 \text{ N/mm}^2$$

$$\frac{100 A_s}{b d} = 0.1980$$

Table 19 of the *IS 456:2000* gives,

$$\tau_c = 0.32 \text{ N/mm}^2$$

With

$$k = 1.0$$

Equation 12.21 gives,

$$\tau_a = \tau_c = 0.32 \text{ N/mm}^2$$

With

$$\tau_v = \tau_a, D = 50 \text{ mm is safe}$$

(v) **Check on development length of footing bars**

Table (11.13) gives, for footings bars of $\phi 12$ Fe 415),

$$L_d(\text{tension}) = 55 \phi = 660. \text{ mm}$$

Equation 12.25 gives,

$$y = \frac{1}{2} A - \frac{1}{2} a - 4 = 921. \text{ mm}$$

with $y > L_d$ (tension), footing bars will develop full strength at the critical section.

It may be noted that with $D = 500. \text{ mm}$, this type of footing of uniform depth is not economical. Footing of Types (b) and (c) with sloping depth would be more economical than the present design.

Example 12.2. Rectangular sloped footing of Type (c).

Given:

Same as in Ex. 12.1 with

$$a = 400mm$$

$$b = 600mm$$

and the footing is to have equal overhangs on all sides of column.

Required: Design the footing

Solution:

(i) **Dimensions of footing**

Equation12.1 gives,

$$A \times B = \frac{P}{p} = 5.005 \times 10^6$$

$$A \times B = \frac{1000}{0.02} = 50000mm^2$$

The equal overhang condition, Equation12.9 gives,

$$-a + b = -A + B = 200$$

The solution of these two equations gives,

$$A = 2140mm$$

$$B = 2340mm$$

Practical designer may choose $A = 2140mm$ and $B = 2340mm$

$$p = \frac{P}{AB} = 200.kN/m^2$$

Table12.1 gives for $p = .02$ and steel Fe 415,

$$\frac{D}{A} = \frac{1}{4.5} \times 1.20$$

$$D = \frac{2}{15} A + \frac{2}{15} B = 600.mm$$

$$D = 600.mm \text{ and } D_m = 150.mm$$

(ii) **Check for perimeter shear**

Equation12.8 gives, with $c = 40mm$, $\phi = 12.mm$,

$$d = D - c - \phi = 545.mm$$

Equation12.9 gives,

$$\alpha = \frac{D_m}{d} - \frac{c + \phi}{d} + \frac{(D - D_m)(\frac{a}{A} + \frac{d}{A} - 1)}{d(\frac{a}{A} - 1)} = 0.74$$

Chart12.1 gives for,

$$k = \frac{670. \alpha \sqrt{f_{ck}}}{p} = 9.64$$

$$\frac{a}{A} (\text{average value}) = \frac{a + b}{A + B} = 0.22$$

$$\frac{A}{d} = 4.98 \text{ or } d = 0.201 A = 429.$$

$$D = c + d + \phi = 481.mm$$

$D = 600.mm$ is safe in perimeter shear.

(iii) Design for moment

Equation 12.11 gives,

$$M_{1-1} = \frac{1}{8} (A - a)^2 B p = 176.9 \text{ kNm}$$

with trapezoidal compression zone, Chart 4.1 gives for,

$$b = 600 \text{ mm}, d = 545 \text{ mm}$$

$$\tan \beta = \frac{2(D - D_m)}{B - b} = 0.5156$$

$$\gamma = \frac{d}{b \times \tan \beta} = 1.8$$

$$k = \frac{200000 M_{1-1} \gamma f}{3 b d^2} = 0.12$$

$$\mu = 0.11$$

$$A_{st} = \frac{100 b d f_{ck} \mu}{87 f_y} = 1494 \text{ mm}^2$$

$$\frac{A_{st}}{B} = 638.5 \text{ mm}^2/\text{m}$$

Minimum steel for average value of $D = \frac{1}{2} D + \frac{1}{2} D_m = 373 \text{ mm}$ regarding footings as slabs,

$$A_{st}(\text{min}) = 1.2 \times 373 = 448 \text{ mm}^2/\text{m}$$

Provide ϕ 12/177 c/c bothways, area = 638.6 mm²/m

(iv) Design for beam shear

Equation (12.12) gives

$$S_{2-2} = \frac{1}{2} (A - a - 2 d_m) B p = 152 \text{ kN}$$

Equation (12.16) gives,

$$D' = D_m + \frac{(D - D_m) \left(\frac{a}{A} + \frac{2d}{A} - 1 \right)}{\frac{a}{A} - 1} = 316 \text{ mm}$$

Equation (12.17) gives,

$$d' = D' - c - \phi = 264 \text{ mm}$$

Equation (12.18) gives,

$$b' = b + \frac{2(B - b)d}{A - a} = 1691 \text{ mm}$$

Equation (12.13) gives

$$M_{2-2} = \frac{1}{8} (A - a - 2 d)^2 B p = 24.629 \text{ kNm}$$

Equation 12.15 gives,

$$\tau_v = \frac{228}{1691 \times 264} = \frac{1.5 \times 24.629 \times 0.5156}{1691 \times (264)^2}$$

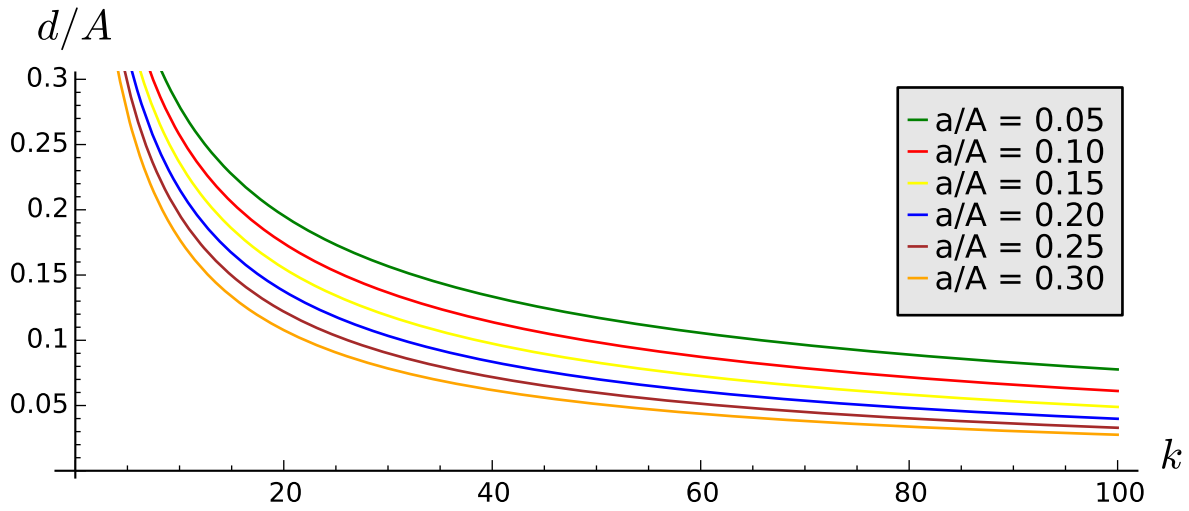

Chart 12.1: Effective Depth (d) of Square Individual Footings for Safety of perimeter shear

$$\tau_v = 0.510N/mm^2$$

For

$$\frac{100 A_s}{b' d'} = 0.242$$

Table19 gives $\tau_c = 0.35 N/mm^2$

$$k = 1.0, \tau_u = \tau_c = 0.0350N/mm^2 > \tau_u = 0.34N/mm^2,$$

$D = 600.mm$ is safe in beam shear

(v) **Check on development length of footing bars**

Table(11.3)gives for ϕ 12 bars

$$L_d(\text{tension}) = 55 \phi = 660mm$$

Chart12.1 Effective Depth (d) of Square Individual Footings for Safety in perimeter shear.

$$k = \frac{\left[1 - \left(\frac{a}{A}\right)^2 - 2 \left(\frac{a}{A}\right)^2 \left(\frac{d}{A}\right) - \left(\frac{d}{A}\right)^2 \right]}{\left[\left(\frac{a}{A}\right) \left(\frac{d}{A}\right) + \left(\frac{d}{A}\right)^2 \right]}$$

$$k = 0.067 \frac{\sqrt{f_{ck}}}{p}$$

Equation12.25 gives,

$$y = \frac{1}{2} A - \frac{1}{2} a - 4 = 866.mm > 660mm \text{ OK,}$$

Notes:

1. f_{ck} in N/mm^2
2. p in kN/mm^2
3. For rectangular column $a \times b$ Assume $a = \frac{(a+b)}{2}$ as in approximation provided $a/b \leq 0.50$.

4. Chart can be used for squarish rectangular footings provided an equal overhang is left beyond faces of column with $A = \frac{A+B}{2}$
For equal overhang $(b-a) = (B-A)$

5. $\alpha = 1.0$ for types (a),(b) and (d)(Fig.12.1)

6. $\alpha < 1.0$ for type (c). Use Equation12.9

$$7. \alpha = \frac{D_m}{d} + \frac{D - D_m}{d} \cdot \frac{\left(1 - \frac{a}{A} - \frac{d}{A}\right)}{\left(1 - \frac{a}{A}\right)} - \frac{(c + \phi)}{d}$$

12.8 Conclusion

Provisions of the *IS456:2000* on footings have been applied to individual spread footings, square, or rectangular in plan with depth uniform, varying or stepped. Design aids are given for fixing depth of footings and checking it in respect of requirements of safety in perimeter shear. Procedure for design of footings for bending moment, shear and development length of tension steel bars is given in detail and examples are given to illustrate it. For a large-sized rectangular footing, a footing beam in the long direction will be more economical than the traditional isolated footing. Also, for large square footings, two cross footing beams with a uniform base slab will make for economy.

p(kN/m ²)	A/D	Fe415,Fe500
50	8	7
100	6	5.5
150	5.5	5
200	5	4.5
250	4.5	4
300	4	3.5

Table 12.1: Depth of Footing for Safe Bearing Capacity

Note:

1. 'A' is the average of sides of rectangular footing.
2. For sloped (type c) and stepped (type d) footings, increased depth given by the above table by 20%.

Bibliography

- [1] ACI Committee 318. *ACI Standard Building Code Requirements for Reinforced Concrete (ACI 318-77)*. ACI standard 318-77. American Concrete Institute, 1981. URL: <https://books.google.co.in/books?id=amE0fgtA-DYC>.
- [2] *IS456:1964*.
- [3] *IS456:2000*.