



KV/IRC/3

RV/IRC/3



KV/IRC/3

IRC: 83 (Part II) - 1987

**STANDARD SPECIFICATIONS
AND
CODE OF PRACTICE
FOR
ROAD BRIDGES**

**SECTION : IX
BEARINGS
PART II : ELASTOMERIC BEARINGS.**



**THE INDIAN ROADS CONGRESS
1996**

Devlkarpani
Dec 96

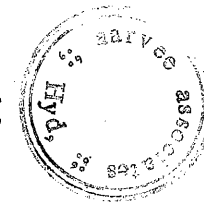

NY 13K410

IRC : 83 (Part II)-1987

**STANDARD SPECIFICATIONS
AND
CODE OF PRACTICE
FOR
ROAD BRIDGES**

**SECTION : IX
BEARINGS**

PART II : ELASTOMERIC BEARINGS

Published by
THE INDIAN ROADS CONGRESS
Jamnagar House, Shahjahan Road,
New Delhi-110 011
1996

Price Rs. 48.00
(Plus packing & postage)

First published : June, 1987

Reprinted : March, 1991

Reprinted : January, 1996

CONTENTS

	<i>Page No.</i>
Introduction	1
912. Scope	2
913. Terminology	2
914. Notations	4
915. Materials	5
916. Design	8
917. Fabrication	11
918. Acceptance Specification	13
919. Certification and Marking	19
920. Installation	20
921. Maintenance	22
<i>Appendix 1 : Standard Plan Dimensions and Design Data</i>	23
<i>Appendix 2 : Test on Complete Bearings or Sections</i>	24
<i>Appendix 3 : Quality Control Report</i>	29

(Rights of Publication and Translation are Reserved)

BEARINGS

Part II : ELASTOMERIC BEARINGS

INTRODUCTION

The Subcommittee for preparing Standard Specifications and Code of Practice for Bridge Bearings and Expansion Joints (personnel given below), finalised the Code of Practice for Elastomeric Bearings Part II, in their meeting held at New Delhi on the 4th April, 1987.

L.S. Bassi	... <i>Convenor</i>
A.D. Narain	... <i>Member-Secretary</i>

MEMBERS

B.K. Bassi	Achyut Ghosh
J.N. Chaudha	D.T. Grover
S.P. Chakraborti	Brijendra Singh
V.P. Deshpande	Dr. P. Ray Choudhury
A.K. Gupta	Dr. T.N. Subba Rao
P.S. Gokhale	Secretary, IRC (Ninan Koshi)- <i>Ex-officio</i>

President, IRC and Director General (Road Development) & Addl. Secretary to the Govt. of India (K.K. Sarin)—*Ex-officio*

The Bridges Committee considered and approved the said draft in their meeting held at New Delhi on the 28th April, 1987. Later the Code of Practice was approved by the Executive Committee and the Council in their meetings held on the 28th April, and 22nd May, 1987 respectively.

This Specification and Code of Practice is being brought out in four parts, Part I deals with Metallic Bearings, Part II with Elastomeric Bearings, Part III with PTFE Bearings, and Part IV with Expansion Joints.

The Part I of the Code relating to Metallic Bearings has since been published as IRC:83-1982.

The provisions of this Code Part II, pertaining to Elastomeric Bearings are meant to serve as a guide to both the design and construction engineers, but mere compliance with the provisions stipulated herein will not relieve them in any way of their responsibility for the overall stability and soundness of the structure designed and erected.

Clauses 900 to 911 and Figs. 1 to 7 relating to Part I Metallic Bearings of this Code are printed in IRC : 83-1982.

912. SCOPE

912.1. This Section of the Specifications (referred to as 'Code' hereinafter) shall apply to laminated rectangular free elastomeric bearings, Fig. 8, for common use in road bridges and satisfying the following:

- (i) The internal layers of elastomer shall be of equal thickness, having elastomer cover on top, bottom and sides and the entire bearing vulcanised as a single homogenous block.
- (ii) The top and bottom elastomer surfaces shall directly bear on the structure faces and any displacement of the bearing safe-guarded by only interface friction, without the aid of adhesive or other external anchoring devices.
- (iii) No dowel holes in elastomer and laminate shall be provided including those filled in subsequently.
- (vi) For locations where the minimum atmospheric temperature drops below zero °C for continuous periods of 24 hours or more, the provision of this Code shall not apply.

912.2. Relevant provisions of this Code, suitably supplemented and modified may be applied to some other types of elastomeric bearings as given below, subject to prior approval of the engineer :

- (i) Free bearing circular
- (ii) Free bearing—rectangular or circular with dowel holes (for alignment of laminates during fabrication), subsequently filled in
- (iii) Free bearing, rectangular or circular, secured against displacement with the aid of adhesive or other positive attachment.
- (iv) Fixed bearing, anchored with dowels.

913. TERMINOLOGY**913.1. Crystallisation**

A phase change in elastomer (arrangement of previously disordered polymer segments of repeating patterns into geometric symmetry) promoted by very low temperature and marked by large and quick changes in hardness, stiffness, shear modulus, etc. which are reversible.

913.2. Chloroprene Rubber (CR)

Also known as polychloroprene is a polymerised form of the monomer chloroprene.

913.3. Elastomer

Any member of a class of polymeric substances obtained

after vulcanisation and possessing rubber like-properties, especially the ability to regain shape almost completely after large deformation.

913.4. Elastomeric Bearing

A bearing consisting of one or more internal layers of elastomer bonded to internal steel laminates by the process of vulcanisation. The bearing caters for translation and/or rotation of the superstructure by elastic deformation.

913.5. Engineer

The Engineer-in-Charge, official of the highway administration, responsible for the execution of the bridge project and so designated in the contract or his authorised representative.

913.6. Inspector

Authorised representative of the engineer for acceptance testing of given lots of bearings at the manufacturers' plant.

913.7. Laminate

A layer of reinforcing material integrally bonded to elastomer during vulcanisation process, to restrain the lateral expansion of the elastomer.

913.8. Laminated Bearing

A bearing composed of alternate layers of elastomer and laminates, integrally bonded during vulcanisation.

913.9. Ethyl Propylene Dimonomer (EPDM) Isobutane Isoprene Copolymer (IIR) Chloro-Isoprene Copolymer (CIIR)

Synthetic rubber like materials capable of being used in bridge bearings by the process of vulcanisation (not permitted by this Code) but have enjoyed limited use in various parts of the world.

913.10. Natural Rubber (NR) (Polyisoprene)

A polymer occurring naturally in the sap of certain plants, particularly *Hevea Brasiliensis*.

913.11. Raw Elastomer

This shall be virgin polychloroprene (CR) capable of being vulcanised with compounds to produce an elastomeric bearing.

913.12. Shore Hardness

Mechanical property of a material which describes its resistance to indentation of a standard device (i.e. durometer) and measured in degrees on several scales (I.R.H. Shore A, Shore B, etc.).

914. NOTATIONS

A	=	$l \times b$ —effective plan area of bearing excluding cover common to that of laminate
b	=	effective width of bearing (excluding cover) common to that of laminate, Fig. 8
b_o	=	$b + 2c$, overall width of bearing (including cover), Fig. 8
c	=	side cover, Fig. 8
d	=	denotes design value
E	=	elastic modulus (modulus of longitudinal deformation) of steel/concrete in superstructure
E_a	=	Apparent elastic modulus of bearing
E_e	=	Elastic modulus (instantaneous) of concrete
$E_{c\alpha}$	=	Equivalent elastic modulus of concrete in superstructure accounting for creep, shrinkage, etc.
G	=	Shear modulus
h_o	=	Outer dimension
h	=	$n.h_i + 2h_e$, total elastomer thickness
h_i	=	thickness of individual internal layer of elastomer, Fig. 8
h_e	=	thickness of top/bottom outer layer of elastomer, Fig. 8
h_{max}, h_{min}	=	maximum and minimum values of h permitted
h_s	=	thickness of steel laminate, Fig. 8
H_u	=	Horizontal load acting on the bearing, design value
H_{test}	=	maximum horizontal load used in acceptance testing (Appendix 2)
I	=	moment of inertia of superstructure section
l	=	effective length of bearing (excluding cover) common to that of laminate, Fig. 8
l_o	=	$l + 2c$, overall length of bearing
L	=	span length of superstructure measured between centre lines of bearings
M_{max}	=	maximum mid-span bending moment in superstructure
n	=	total number of internal elastomer layers
n_{max}, n_{min}	=	maximum and minimum permissible number of internal elastomer layers
N_d	=	normal load applied to the bearing, design value

N_{max}	=	maximum permissible N , design capacity
N_{min}	=	minimum permissible N , design capacity
N_{test}	=	N used in acceptance testing (Appendix 2)
S	=	shape factor; ratio of one loaded surface area to the surface area free to bulge, for an internal layer of elastomer (excluding side cover)
α_d	=	total angle of rotation due to imposed loads and support rotation of the superstructure design, value.
α_{bd}, α_{ld}	=	angle of rotation across the width b and the length l (if any) of the bearing
$\alpha_{it, max}$	=	maximum permissible angle of rotation of a single internal layer of elastomer corresponding to σ_m value of 10 MPa (across b)
$\alpha_{lt, max}$	=	maximum permissible angle of rotation of a single internal layer of elastomer corresponding to σ_m value of 10 MPa (across l)
β	=	$\sigma_m/10$, ratio of acting σ_m to permissible value
Δd	=	Imposed translation of elastomer bearing due to longitudinal deformation (temperature, shrinkage, creep, etc.) of superstructure, design value
$\Delta b_d, \Delta l_d$	=	translation in the direction of width ' b ' and the length ' l ' (if any) of the bearing
Δh	=	Vertical deformation
γ_d	=	shear strain of elastomer bearing, design value
γ_{bd}, γ_{ld}	=	shear strain in the direction of width ' b ' and the length ' l ' (if any) of the bearing
σ_m	=	N/A —Average compressive stress
τ_m	=	H/A —Average shear stress
τ_c	=	Shear stress due to axial compression
τ_r	=	Shear stress due to horizontal deformation
τ_α	=	Shear stress due to rotation
		Note : SI units shall be used.

915. MATERIALS

915.1. Raw Material

Chloroprene (CR) only shall be used in the manufacture of bearing.

915.1.1. Grades of raw elastomer of proven use in elastomeric bearings, with low crystallisation rates and adequate shelf life (e.g. Neoprene WRT, Bayprene 110 or equivalent) shall be used.

915.1.2. No reclaimed rubber or vulcanised wastes shall be used.

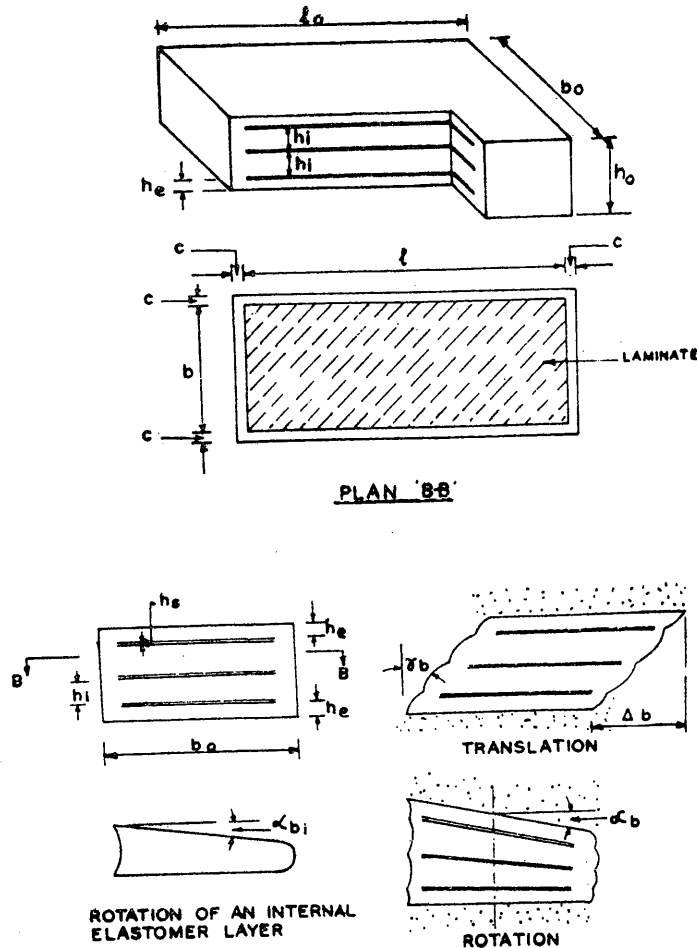

Fig. 8. Elastomeric bearing : General features

915.1.3. The raw elastomer content of the compound shall not be lower than 60 per cent. The ash content shall not exceed 5 per cent. (As per tests conducted in accordance with ASTM D-297).

915.1.4. EPDM and other similar candidate elastomers for bridge bearing use shall not be permitted.

915.2. Properties

The elastomer shall conform to all the properties specified in Table 1.

TABLE 1. (Refer Clause 915.2)
PROPERTIES OF ELASTOMER

Property	Unit	Test method, I.S. Specification reference	Value of the characteristic specified
(1)	(2)	(3)	(4)
1. Physical properties			
1.1. Hardness	IRHD	IS : 3400 (Part II)	60 ± 5
1.2. Minimum tensile Strength	MPa	IS : 3400 (Part I)	17
1.3. Minimum elongation at break	%	IS : 3400 (Part I)	400
2. Maximum compression set			
	%	IS : 3400 (Part X) duration (h) temperature (°C)	
C.R.		(+0 to 24-2) 100 ± 1	35
3. Accelerated ageing			
		IS : 3400 (Part IV) duration (h) temperature (°C)	
C.R.		70 100 ± 1	
3.1. Maximum change in hardness	IRHD		+ 15
3.2. Maximum change in tensile strength	%		- 15
3.3. Maximum change in elongation	%		- 40

IRC : 83 (Part II)-1987

915.2.1. Shear modulus of the elastomer bearing shall not be less than 0.80 MPa nor greater than 1.20 MPa.

915.2.2. The adhesion strength of elastomer to steel plates determined according to IS : 3400 Part XIV method A shall not be less than 7kN/m.

915.2.3. For elastomeric bearings (CR) used in adverse climatic conditions the following ozone resistance test shall be satisfied :

The ozone resistance of elastomer shall be proved satisfactory when assessed by test according to IS : 3400 Part XX. The strain, temperature, duration and ozone concentration for the test shall be 20 per cent, $40 \pm 1^\circ\text{C}$, 96 h and 50 ppm by volume respectively. No cracking detected by visual observation at the end of the test shall be considered satisfactory. No specific tests for assessment of low temperature resistance may be deemed necessary.

Note : For use of elastomer in extreme cold climates, Engineer may specify special grade of low temperature resistant elastomer in conformity with operating ambient temperature conditions. The specifications of such special grade elastomer including the tests for low temperature resistance shall be mutually agreed to by the engineer and the producer supplier and are outside the purview of this Code.

915.3. Laminates of mild steel conforming to IS : 226 shall only be permitted to be used. Use of any other materials like fibre-glass or similar fabric as laminates are not permitted for the purpose of this Code.

916. DESIGN

916.1. The following design values of local effects applicable to bearing under design shall be determined by suitable analysis of structure under any critical combination of loads at their service values as specified in IRC : 6.

- (1) Normal loads N_d
- (2) Horizontal load H_d
- (3) Imposed translation Δ_d
- (4) Rotation α_d

Components both in the direction of the width 'b' and length 'l' of the bearing shall be assessed, where relevant.

The most critical values from all load combinations including seismic, wind, etc. shall be adopted (no increase in permissible

limits given in design criteria 916.3.3. to 916.3.7. shall be made for seismic, wind and other load combinations).

916.2. Plan Dimensions

916.2.1. Standard plan dimensions conforming to *Appendix I* shall be preferred. However, interpolation of plan dimensions is permitted if deemed necessary, provided these conform to clause 916.3.

916.2.2. If bearings conforming to standard plan dimensions are, used the following design criteria shall be satisfied :

- (i) The design vertical load N_d shall not be greater than N_{max} nor less than N_{min} given in *Appendix I* (corresponding to the size Index No.)
- (ii) The average normal stress σ_n shall not exceed the concrete contact pressure permitted according to Clause 307 of IRC : 21.
- (iii) Thickness of individual elastomer layer h_i shall conform to any of those given in *Appendix I*. (corresponding to the size Index No.)
- (iv) Thickness of outer layers shall be $h_o = h_i/2$ subject to a maximum of 6 mm and side cover shall be 6 mm for all bearings.
- (v) The number of internal layers of elastomer shall not be greater than n_{max} nor less than n_{min} given in *Appendix I* (corresponding to size Index No.)
- (vi) The number of internal layers of elastomer chosen shall satisfy the limits of translation, rotation friction and total shear stress given in Clauses 916.3.4.; 916.3.5.; 916.3.6. and 916.3.7. respectively where α_i, m_{ax} shall be read from the Table given in *Appendix I*.
- (vii) Thickness of steel laminates shall be 3 mm for $h_i = 8$ and 10 mm and 4 mm for $h_i = 12$ mm.

916.2.3. Bearings with plan dimensions interpolated between those shown in the standard plan dimension in *Appendix I* shall conform to the design criteria given in Clause 916.3.

916.3. Design Rules

916.3.1. Thickness of all internal layers of elastomer ' h_i ' in any elastomer bearing shall conform to one of the following :

- (i) 8 mm
- (ii) 10 mm
- (iii) 12 mm
- (iv) 16 mm (for special use)

916.3.2. Thickness of outer layers shall be $h_o = h_i/2$ subject to a maximum of 6 mm and side cover shall be 6 mm for all bearings.

IRC : 83 (Part II)-1987

916.3.3. The dimensioning of the bearing and the number of internal layers of elastomer chosen shall satisfy the following criteria :

- (1) Plan dimensions shall conform to R' 20 series of IS : 1076.
- (2) $l_0/b_0 \leq 2$
- (3) $h \leq b_0/5$ & $\geq b_0/10$
- (4) h_i (mm) 8 10 12 16
- (5) h_s (mm) 3 3 4 6
- (6) h_o (mm) 4 5 6 6
- (7) $c = 6$ mm
- (8) $S > 6$
 ≤ 12

Note : h_s for laminates with dowel holes shall not be less than 4 mm for $h_i \leq 10$ mm; and 6 mm for $h_i \geq 12$ mm.

916.3.4. Translation

- (1) Elastomer thickness provided shall satisfy the following :

$$\gamma_a \leq 0.7$$

where $\gamma_a = \gamma_{ba} = \Delta_{ba}/h + \tau_{ma}$ (where τ_{ma} is in MPa)

or in case of γ_{ia} co-existing

$$\gamma_a = (\gamma_{ba}^2 + \gamma_{ia}^2)^{1/2}$$

(2) In absence of more accurate analysis, Δ_{ba} the longitudinal translation due to creep; shrinkage, temperature etc. can be computed assuming a total longitudinal strain of 5×10^{-4} for common reinforced concrete bridge decks.

916.3.5. Rotation

- (1) The number of elastomer layers provided shall satisfy the following :

$$\alpha_a \leq \beta n. \alpha_{di, max}$$

where $\alpha_a = \alpha_{ba}$ and $\alpha_{di, max} = \frac{0.5 \sigma_m h_i}{b.S^2}$

or in case of α_{ia} co-existing

$$\alpha_a = (\alpha_{ba} \cdot b + \alpha_{ia} l)/b$$

Note : For calculating α_{di} , σ_m shall be taken as 10 MPa

- (2) In absence of more accurate analysis, α_a for simply supported spans may be computed by the following :

$$\alpha_{ba} = 400 M_{max} L/(EI) 10^{-3}$$

For concrete, creep effects may be catered for by assuming an equivalent modulus of $E_e \alpha = E_c/2$ for permanent loads, in absence of more accurate analysis.

916.3.6. Friction : The following limit shall be satisfied under any critical design load combination.

$$\gamma_a \leq 0.2 + 0.1 \sigma_m$$

$$10 \text{ MPa} \geq \sigma_m \geq 2 \text{ MPa}$$

916.3.7. Total shear stress

$$\tau_c + \tau_Y + \tau_a \leq 5 \text{ MPa}$$

where $\tau_c = 1.5 \sigma_m/S \text{ MPa}$

$$\tau_Y = \gamma_a \text{ MPa}$$

$$\tau_a = 0.5 \left(\frac{b}{h_i} \right)^2 \alpha_{bi} \text{ MPa}$$

where α_{ii} co-exists

$$\tau_a = \frac{0.5}{h_i^2} (b^2 \alpha_{bi} + l^2 \alpha_{ii})$$

917. FABRICATION

917.1. Bearing with steel laminates shall be cast as a single unit in a mould and vulcanised under heat and pressure.

Casting of elements in separate units and subsequent bonding is not permitted, nor shall cutting from large size cast be permitted.

917.2. Bearings of similar size to be used in particular bridge project shall be produced by identical process and in one lot as far as practicable. Phased production may only be resorted to when the total number of bearings is large enough.

917.3. The moulds used shall have standard surface finish adequate to produce bearings free from any surface blemishes.

917.4. Steel plates for laminates shall be sand blasted, clean of all mill scales and shall be free from all contaminants prior to

bonding by vulcanisation. Rusted plates with pitting shall not be used. All edges of plates shall be rounded.

917.5. Spacers used in mould to ensure cover and location of laminates shall be of minimum size and number practicable. Any hole at surface or in edge cover shall be filled in subsequently.

917.6. Care shall be taken to ensure uniform vulcanising conditions and homogeneity of elastomer through the surface and body of the bearing.

917.7. The bearings shall be fabricated with the tolerances specified in Table 2.

TABLE 2. TOLERANCES

ITEMS	TOLERANCES
1. Overall plan dimensions (l_0, b_0)	-0, + 6 mm
2. Total bearing thickness (h_0)	-0, + 5%
3. Parallelism	
(a) Of top surface of bearing with respect to the bottom surface as datum	1 in 200
(b) Of one side surface with respect to the other as datum	1 in 100
4. (a) Thickness of individual internal layer of elastomer (h_t)	$\pm 20\%$ (maxm of 2 mm)
(b) Thickness of individual outer layer (h_o)	-0, + 1 mm
5. (a) Plan dimensions of laminates (l, b)	-3 mm, + 0
(b) Thickness of laminate	$\pm 10\%$
(c) Parallelism of laminate with respect to bearing base as datum	1 in 100

917.8. The vulcanising equipment/press should be such that between the platens of the press the pressure and temperature are uniform and capable of being maintained at constant values as required for effecting an uniform vulcanisation of the bearing.

917.9. The moulding dies utilised for manufacturing the bearings should be so set inside the platen of the press so that the pressure developed during vulcanisation of the product is evenly distributed and the thickness maintained at all places are within acceptable tolerance limits taking into consideration, the shrinkage allowance of vulcanizate.

917.10. The raw compound which has been introduced inside the metal dies for vulcanisation, should be accurately weighed each time and it must be ensured that sufficient quantity has been put inside the die for proper flow of material at every place so that a homogeneous and compact bearing is produced without any sign of sponginess or deficiency of material at any place.

917.11. Before any vulcanizate of any batch of production is used for producing vulcanised bearings, test pieces in the form of standard slab and buttons should be prepared in accordance with prescribed standards and salient properties tested and recorded regularly against each batch of production to monitor the quality of the products.

918. ACCEPTANCE SPECIFICATION

918.1. The manufacturer shall have all test facilities required for process and acceptance control tests installed at his plant to the complete satisfaction of the engineer. The test facilities and their operation shall be open to inspection by the engineer on demand.

918.1.1. All acceptance and process control tests shall be conducted at the manufacturers plant. Cost of all materials, equipment and labour shall be borne by the manufacturer unless otherwise specified or specially agreed to between the manufacturer and engineer.

918.1.2. Acceptance testing shall be commenced with the prior submittal of testing programme by the manufacturer to the engineer and after obtaining his approval.

918.1.3. Any acceptance testing delayed beyond 180 days of production shall require special approval of the engineer and modified acceptance specification, if deemed necessary by him.

918.1.4. All acceptance testing shall be conducted by the inspector with aid of the personnel having adequate expertise and experience in rubber testing provided by the manufacturer, working under the supervision of inspector and to his complete satisfaction.

918.1.5. Lot by lot inspection and acceptance shall be made.

918.2. Acceptance Lot

A lot under acceptance shall comprise all bearings, including the pair of extra test bearings where applicable (Clause 918.3.1), of equal or near equal size produced under identical conditions of manufacture to be supplied for a particular project.

918.2.1. The size and composition of acceptance lot shall be got approved by the engineer.

918.2.2. For the purpose of grading levels of acceptance testing (Clause 918.3) lots will be classified as below :

- (i) A lot size of 24 or larger number of bearings shall be defined as a *large lot*.
- (ii) A lot size of less than 24 bearings shall be defined as a *small lot*.

918.2.3. When the number of bearings of equal or near equal size for a single bridge project is large and phased production and acceptance is permitted, the number of bearings supplied in any single phase of supply shall comprise a lot under acceptance. When such phased supply is made, each such lot shall be considered as a large lot for the purpose of acceptance testing.

918.3. Levels of Acceptance Inspection

The level of acceptance testing shall generally be graded into the following two levels depending on lot size :

Level 1 acceptance testing

Level 2 acceptance testing

918.3.1. Acceptance testing level 1 is a higher level inspection and shall be applicable to large lots only, unless otherwise specified (Clause 918.2.3.). This shall involve manufacture of two extra bearings for each lot to be used as test bearing and eventually consumed in destructive testing.

918.3.2. Acceptance testing level 2 shall be applicable to small lots only, unless otherwise specified and shall not involve any destructive testing of finished bearings.

918.3.2.1. Acceptance inspection level 1 may be specified at the sole discretion of the engineer, taking into account the special importance of bridge project, for small lots also under the purview of special acceptance inspection (Clause 918.5). The cost of extra test bearings, in such cases shall be borne by the user,

while cost of all other materials, equipment and testing shall be borne by the manufacturer.

918.4. Testing

Acceptance testing shall comprise

General inspection

Test on specially moulded test pieces

Test on complete bearings or sections for measurement of various quality characteristics detailed below :

918.4.1. Acceptance testing level 1**918.4.1.1. General inspection**

(1) All bearings of the lot shall be visually inspected for absence of any defects in surface finish; shape or any other discernible superficial defects.

(2) All bearings of the lot shall be checked for tolerances specified in Table 2.

(3) All bearings of the lot shall be subjected to an axial load to correspond to $\sigma_m = 15$ MPa applied in steps and held constant while visual examination is made to check for discernible defects like :

Misalignment of reinforcing plates

Poor bond at laminate/steel interface

Variation in h_i or h_e

Any surface defects

Low stiffness

Deflection under loads between $\sigma_m = 5$ MPa and $\sigma_m = 15$ MPa shall be measured and recorded for all bearings with sufficient accuracy (± 5 per cent). Variation in stiffness of any individual bearing from the mean of the measured values for all such bearings of the lot shall not be larger than 20 per cent (of the mean value).

918.4.1.2. Tests on specially moulded test pieces

(1) Test pieces shall be moulded by the manufacturer with identical compound and under identical vulcanising conditions as used in the manufacture of the bearings of the acceptance lot. The process shall be open to inspection by the inspector or engineer.

(2) Test pieces offered for inspection shall be identified by suitable markings and duly certified by the manufacturer.

(3) The quality characteristics to be tested are listed below. The specification references in parenthesis shall define the corresponding specification for test piece, test method and criterion of acceptance.

- Composition (Clause 915.1.3.; see Note 1 below)
- Hardness (Table 1-1.1)
- Tensile Strength (Table 1-1.2)
- Elongation at Break (Table 1-1.3)
- Compression Set (Table 1-2)
- Accelerated Ageing (Table 1-3)
- Adhesion Strength (Clause 915.2.2.)
- Ozone Resistance (Clause 915.2.3. see also Note 2 below)

Note 1 : For acceptance testing level 1 the ash content (%) and specific gravity of elastomer of test pieces from test bearing shall be compared with those for corresponding specially moulded test pieces furnished by the manufacturer. The following variations shall be deemed maximum acceptable.

Specific gravity	± 0.2
Ash content	± 0.5%
Hardness	(Table 1-1.1)
Tensile strength	(Table 1-1.2)
Elongation at break	(Table 1-1.3)
Compression set	(Table 1-2)
Accelerated ageing	(Table 1-3)
Adhesion strength	(Clause 915.2.2.)

Note 2 : Ozone resistance test can be waived by the engineer for bearings of CR, when satisfactory results of ozone resistance tests on similar grade of elastomer may be available from process control records or development test data furnished by the manufacturer.

Where such process control data are not available or the frequency of testing not deemed adequate, ozone resistance test shall be mandatory for acceptance of bearings of CR.

However, such tests may not be insisted for bearings not located under adverse conditions of exposure and where the test on accelerated ageing could be considered as adequate.

Process and acceptance control tests for ozone resistance by an independent testing agency shall be acceptable.

918.4.1.3. Tests on complete bearings or sections

(1) Two bearings shall be selected at random from the lot as

test bearings. These bearings shall be excluded from the lot accepted.

(2) The following tests shall be conducted on test bearings:

- Test for determination of shear modulus
- Test for determination of elastic modulus (short term loading)
- Test for determination of adhesion strength
- Test for determination of ultimate compressive strength.

The test specifications and acceptance criteria shall conform to those given in *Appendix 2*.

918.4.2. Acceptance testing level 2

918.4.2.1. General inspection : This shall conform to the provision in Clause 918.4.1.1. in all respects.

918.4.2.2. Test on specially moulded test pieces : This shall conform to the provisions in Clause 918.4.1.2. in all respects.

918.4.2.3. Test on complete bearings : Test for determination of shear modulus shall be conducted using two bearings of the lot selected at random and conforming to relevant provisions of Clause 918.4.1.3. These bearings shall, however, be part of the lot accepted.

918.5. Special Acceptance Inspection

918.5.1. Special acceptance inspection may comprise the following:

- (1) Acceptance testing level 1 for the small lots (Clause 918.3.2.1.)
- (2) Acceptance testing by an independent external agency with separate or supplemental test facilities provided by it.
- (3) Acceptance testing on test pieces prepared from the surface or body of the test bearings instead of specially moulded test pieces.
- (4) Acceptance tests not covered by this Code and according to the specifications laid down by the engineer.

918.5.2. Special acceptance inspection may be specified under the following conditions:

- (1) Special contract agreement
- (2) Unsatisfactory evidence of process or acceptance control.

918.6. Inspection Certificate

918.6.1. A lot under inspection shall be accepted by the inspector and so certified, when no defect is found with respect to any of the quality characteristics tested on samples drawn from the lot according to specifications laid down in Clause 918.4. covering general inspection and tests on specially moulded test pieces and on complete bearings.

In case of any bearing with defect, the lot shall be rejected by the inspector and so certified.

918.6.2. In case any bearing is found defective to any quality characteristic, discerned by general inspection specified in Clauses 918.4.1.1. and 918.4.2.1; tests on specially moulded test pieces and complete bearings as applicable according to Clauses 918.4.1.2; 918.4.1.3; 918.4.2.2. and 918.4.2.3. shall nevertheless be completed. If the said lot, rejected by general inspection, satisfies the acceptance criteria in respect of these other tests, the lot and individual bearings found defective shall be clearly identified in the inspection certificate.

918.6.3. The manufacturer shall obtain from the inspector, immediately on completion of his inspection, an inspection certificate which shall include the details of a lot or lots accepted/ rejected by him and records of all test measurements.

918.7. Quality Control Certificate

The manufacturer shall certify for each lot of bearing under acceptance:

That an adequate system of continuous quality control was operated in his plant.

That the entire process remained in control during the production of the lot of bearings under acceptance as verified from the quality control records/charts which shall be open to inspection of the engineer/inspector on demand.

A certified copy of the results of process control testing done on samples of elastomer used in the production of the lot shall be appended and shall include at least the following information.

Composition of the compound—raw elastomer and ash content, the grade of raw elastomer used (include name, source, age on shelf), test results of hardness, tensile strength, elongation at break, compression set, accelerated ageing, etc.

918.7.1. A higher level certification of the process quality control shall be called for at the sole discretion of the engineer in special cases e.g. where adequate historical information about the process from acceptance inspection of bearings similar to those comprising the lot under inspection produced in the same plant is not available with the engineer or in case of any evidence of process or acceptance control being deemed unsatisfactory. The higher level certification shall comprise submittal of a complete quality control report as given in *Appendix 3*, supplementing the quality control certificate.

918.8. Acceptance

918.8.1. The manufacturer shall furnish the following to engineer for the acceptance judgement:

(1) Quality control certificate as laid down in Clause 918.7.

(2) Inspection certificate as laid down in Clause 918.6.

918.8.2. The manufacturer shall furnish any supplementary information on the system of quality control and or process and acceptance control testing as may be deemed necessary by engineer.

918.8.3. In case of any evidence of process or acceptance control testing being deemed unsatisfactory by him, engineer at his sole discretion may call for a special acceptance inspection of the lot according to specifications laid down by him, without any prejudice to his right to reject the lot. The entire cost of such supplementary inspection shall be borne by the manufacturer.

918.8.4. Engineer shall be the sole authority for acceptance of a lot on scrutiny of the certificates according to Clause 918.8.1. along with any supplementary evidence according to Clauses 918.8.2. and 918.8.3; and complete satisfaction therewith.

918.8.5. In case of rejection of a lot, engineer shall reserve the right to call for special acceptance inspection for the succeeding lots offered for inspection, according to the specifications laid down by him. The entire cost of such tightened inspection shall be borne by the manufacturer.

919. CERTIFICATION AND MARKING

919.1. Bearings shall be transported to bridge site after final acceptance by engineer and shall be accompanied by an authenticated copy of the certificate to that effect.

919.2. An information card giving the following details for the bearings, duly certified by the manufacturer shall also be appended:

- Name of manufacturer
- Date of manufacture
- Elastomer grade used
- Bearing dimensions
- Production batch No.
- Acceptance lot No.
- Date of testing
- Specific bridge location, if any
- Explanation of markings used on the bearing

919.3. All bearings shall have suitable index markings identifying the information given in Clause 919.2. The markings shall be made in indelible ink or flexible paint and if practicable should be visible after installation. The top of the bearing and direction of installation shall be indicated.

920. INSTALLATION

920.1. Care shall be taken in packing, transportation, storage and handling to avoid any mechanical damage, contamination with oil, grease and dirt, undue exposure to sunlight and weather.

920.2. Installation of multiple bearings one behind the other on a single line of support is not permitted.

920.3. All the bearings installed along a single line of support shall be of identical dimensions.

920.4. Bearings must be placed between true horizontal surfaces (maximum tolerance 0.2 per cent perpendicular to load) and at true plan position of their control lines marked on receiving surfaces (maximum tolerance ± 3 mm). Concrete surfaces shall be free from local irregularities (maximum tolerance ± 1 mm in height).

920.4.1. Design shall be checked for the actual inclination in seating if larger inaccuracies than those specified in Clause 920.4. are permitted.

920.5. For cast-in-place concrete construction of superstructure, where bearings are installed prior to its concreting, the forms around the bearings shall be soft enough for easy removal. Forms

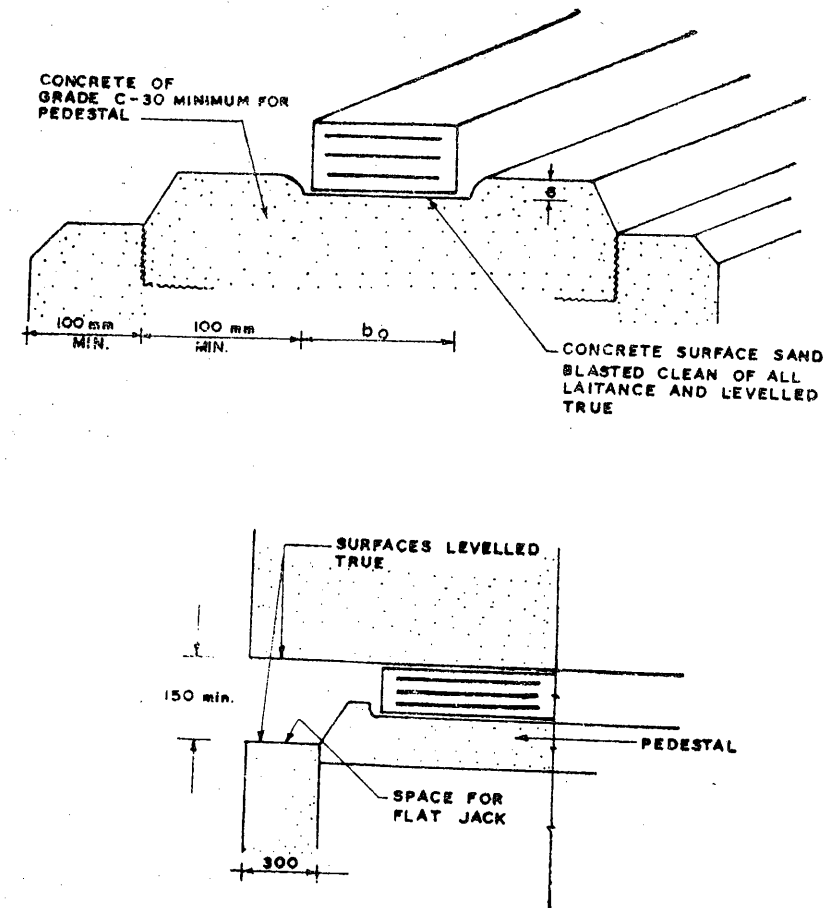

Fig. 9. Pedestal for elastomeric bearing

shall also fit the bearings snugly and prevent any leakage of mortar grout. Any mortar contaminating the bearings during concreting shall be completely removed before setting.

920.6. For precast concrete or steel superstructure elements, fixing of bearing to them may be done by application of epoxy resin adhesive to interface, after specified surface preparation. The specifications for adhesive material, workmanship and control shall be approved by the engineer. Care shall be taken to guard against faulty application and consequent behaviour of the adhesive layer as a lubricant. The bonding by the adhesive shall be deemed effective only as a device for installation and shall not be deemed to secure bearing against displacement for purpose of design.

920.7. As a measure of ample safety against accidental displacement, the bearings shall be placed in a recess as shown in Fig. 9. (This provision shall not be deemed to secure bearings against displacement for the purpose of design).

921. MAINTENANCE

921.1. The bearings shall be subjected to planned maintenance care.

921.1.1. The exposed bearing surface shall be maintained clean and free from contamination with grease or oil, etc.

921.1.2. Annual routine maintenance inspection or special maintenance inspection of all bearings shall be made to check for any surface cracking or signs of damage, deterioration or distress.

921.2. Damaged bearings shall be replaced immediately. To avoid differences in stiffness, all adjacent bearings on the same line of support shall also be replaced.

921.2.1. Arrangements for insertion of jacks to lift the bridge deck shall be made in detailing of the structure (Fig. 9 for a possible arrangement).

Note : The lifting of a cast-in-place post-tensioned bridge deck for relieving time dependent deformation shortly after installation of bearings should be avoided. In case such lifting is unavoidable, the lifting arrangement, proper seating of the girder on the bearing, etc. shall be rigidly controlled to avoid any risk of misalignment.

Appendix I

STANDARD PLAN DIMENSIONS AND DESIGN DATA
(Refer Clause 916.2)

Size Index No.	b_0 mm	l_0 mm	$A.10^{-1}$ mm ²	N_{upper} kN	N_{min} kN	h_i mm	n_{upper}	n_{min}	h_{upper} mm	h_{min} mm	α_d , max. 10^{-3}
1.	160	250	3.5	350	70	8	3	1	32	16	8
2.	160	320	4.6	460	90	8	3	1	32	16	7
3.	200	320	5.8	580	120	8	4	2	40	24	4
4.	200	400	7.3	730	150	8	4	2	40	24	3.5
5.	250	400	9.2	920	180	12	3	1	50	30	4
						12	3	1	48	24	6.5
6.	250	500	11.6	1160	230	10	4	2	50	30	3
						12	3	1	48	24	5.5
7.	320	500	15.0	1500	300	10	5	2	60	30	2
						12	4	2	60	36	3
8.	320	630	19.5	1900	380	10	5	2	60	30	1.5
						12	4	2	60	36	2.5
9.	400	630	23.9	2400	480	12	6	3	84	48	1.5
10.	400	800	30.6	3100	600	12	6	3	84	48	1.3

Notes : 1. When N_{min} , N_{max} limits cannot be simultaneously satisfied, a marginal increase in N_{min} not exceeding 10 per cent over the specified value may be permitted.
2. Where two values of h_i are given, the higher one may be adopted, only when the lower one cannot cater for α_d specified.

TESTS ON COMPLETE BEARINGS OR SECTIONS
(Refer Clause 918.4.1.3.)

1. All tests shall be conducted on test bearings (or sections taken therefrom) chosen at random from the lot under acceptance testing.
2. All testing shall be conducted by skilled personnel under competent supervision with adequate experience in rubber testing, to the complete satisfaction of the inspector.
3. All testing shall be done at room temperatures.
4. No bearings shall be tested earlier than a week after vulcanisation.
5. Bearing sections shall be cut from test bearings without overheating the rubber and with smooth-cut square edges and no after treatment of the section shall be permitted.
6. Test for determination of E_a may precede that of G , when both tests are conducted on the same pair of test bearings.
7. All details of test equipment and method shall be furnished with the submittal of the acceptance testing programme according to Clause 918.1 2. of text.

8. Test for Determination of Shear Modulus

8.1. Scope

The test shall determine the value of shear modulus G under specified short term loading.

8.2. Test Piece

Two test bearings.

8.3. Test Procedure

8.3.1. Test assembly--as in Fig. 10 (a).

8.3.2. Conditioning load : Bearings shall be preloaded with maximum horizontal load H_{test} (with N_{test} held constant) and unloaded before test loading.

8.3.3. Rate of loading : N_{test} corresponding to $\sigma_m = 5 MPa$ shall be held constant during test and the horizontal loading H shall be gradually increased to yield a shear stress rate of approximately 0.05 to 0.1 MPa per minute.

8.3.4. Maximum test loading H_{test} : The horizontal loading H shall be increased upto a maximum H_{test} which corresponds to horizontal deflection equal to h .

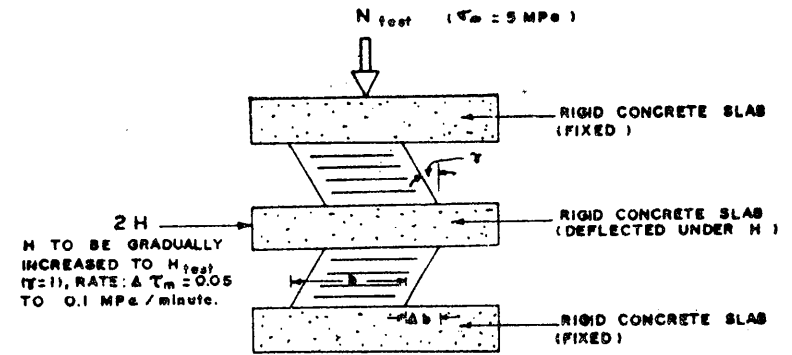

(a) TEST ASSEMBLY

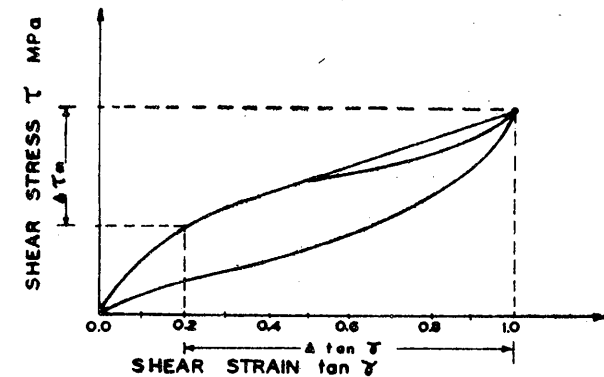

$$\tau_m = H / A$$

$$G = \Delta \tau_m / \Delta \tan \gamma, \text{ MPa}$$

(b) SHEAR STRESS STRAIN CURVE AND G

Fig. 10 Determination of shear modulus

8.3.5. Measurement : Load and deflection measurements shall be made at approximately equal intervals not less than 5.

9. Evaluation

9.1. A shear stress strain curve shall be plotted and the value of shear modulus G determined as shown in Fig. 10 (b).

IRC : 83 (Part II)-1987

9.2. The test result shall be deemed—satisfactory if G determined is within $\pm 20\%$ of 1 MPa and provided there is no evidence of instability, defect or damage discovered by close inspection during the test.

Note : For level 2 acceptance testing, the test bearings used for this test shall not be excluded from the lot under acceptance.

10. Test for Determination of Elastic Modulus

10.1. Scope

The test shall determine the value of apparent elastic modulus E_a under specified short term axial loading.

10.2. Test Piece

Two test bearings.

10.3. Test Procedure

10.3.1. Test assembly as shown in Fig. 11 (a)

10.3.2. Conditioning load : Bearing shall be preloaded upto N_{test} . The load shall be retained for 10 minutes and unloaded upto $\sigma_m = 2 \text{ MPa}$ before test loading.

10.3.3. Rate of loading : The axial load N is increased gradually at a rate yielding approximately $\sigma_m = 0.5 \text{ MPa}$ to 1 MPa per minute.

10.3.4. Maximum test loading N_{test} .

Maximum test loading shall correspond to $\sigma_m = 20 \text{ MPa}$.

10.3.5. Measurement : Load and deflection measurements shall be made in approximately equal load intervals not less than 5. Deflection shall be measured at four edges and mean value accounted for.

10.4. Evaluation

A compressive stress strain curve shall be plotted and the value of apparent elastic modulus E_a shall be determined as shown in Fig. 11 (b).

10.5. Acceptance Criteria

Test result shall be deemed satisfactory if E_a determined is within ± 20 per cent of $1/(0.2/S^2 + 0.0005)$ and provided there is no evidence of any defect or damage discerned by close visual inspection during the test.

11. Test for Determination of Stripping Strength

11.1. Scope

This test shall determine whether requisite adhesion exists between the elastomer and steel laminate.

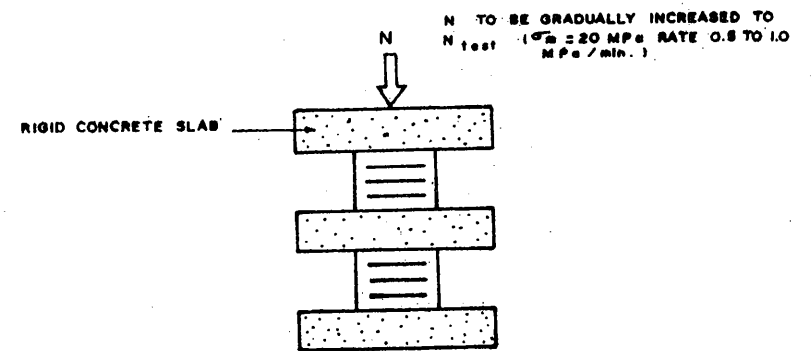

(a) TEST ASSEMBLY

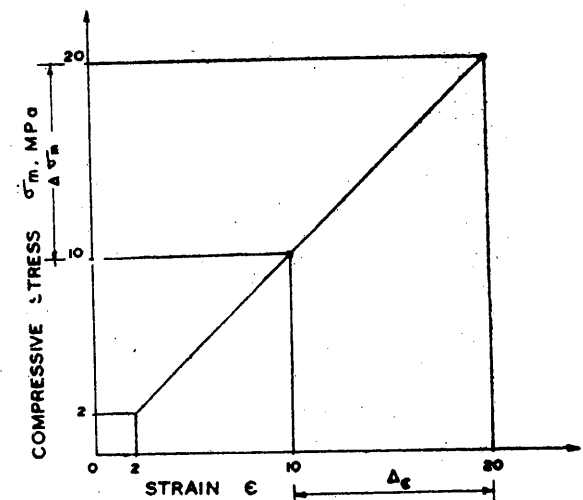

$m = N/A$
 $\epsilon = \Delta h / h$; $\Delta h = \text{VERTICAL COMPRESSIVE DEFLECTION (MEAN OF VALUES MEASURED AT FOUR EDGES)}$

$E_a = \Delta \sigma_m / \Delta \epsilon \text{ MPa}$

(b) COMPRESSIVE STRESS STRAIN CURVE AND E_a

Fig. 11. Determination of elastic modulus

11.2. Test Piece

Two identical test pieces shall be cut from the test bearing. The plan dimensions of each test piece shall not be less than 100 mm × 200 mm, Fig. 12.

Two opposing ends of each test piece shall be bevelled to an angle of 45°.

11.3. Test Procedure

11.3.1. Test assembly : as shown in Fig. 12.

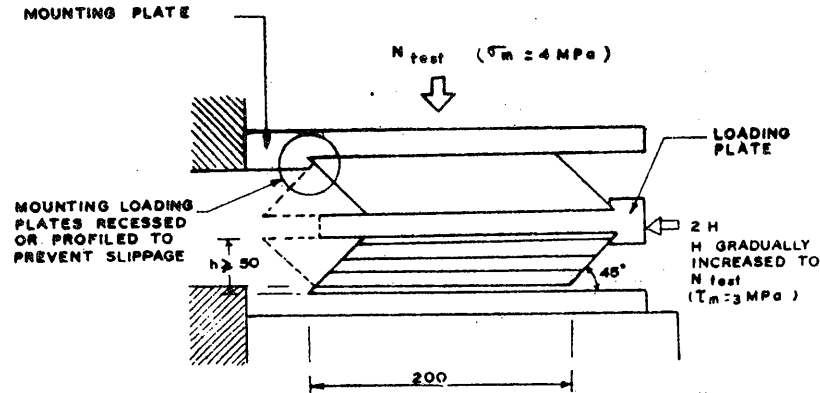

Fig. 12. Determination of adhesion strength

11.3.2. Maximum test loading : N_{test} corresponding to a $\sigma_m = 4 MPa$ is to be held constant during the test.

11.3.3. The horizontal loading H shall be increased gradually upto a maximum yielding $\tau = 3 MPa$.

11.4. Evaluation

Examine the test pieces for evidence of cracking or peeling both in the strained and unstrained state.

11.5. Acceptance Criteria

If neither test piece shows evidence of peeling or separation at or near the interface between rubber and reinforcement layers the bearing shall be deemed to have satisfactory adhesion.

12. Test for Determination of Ultimate Compressive Strength

The test pieces are to be loaded either till the failure of the steel laminate or till the irreversible squeezing out of elastomer whichever is earlier. The test assembly and the test pieces may be identical to Clause 8. However, a small section (not less than 100 × 200 mm) cut from test bearing and testing to failure by placing directly between the plates of the testing machine shall also be permitted. The rate of loading shall not exceed 10 MPa per minute. The result of the test shall be deemed satisfactory if the σ_m at failure is not less than 60 MPa.

QUALITY CONTROL REPORT

(Refer Clause 918.7.1.)

1. Where deemed necessary and so demanded specifically by the engineer, the manufacturer shall furnish to him a complete report on the process quality control comprising the following :

1.1. A general description of the system of quality control including sampling testing and quality control records and/or charts used.

1.2. Test results for the quality characteristics mentioned in Clause 918.4.1.2.(3).

1.3. The information shall pertain to a period not less than 180 days of production of the same grade of elastomeric and the type of bearings as under acceptance.

1.4. Engineer shall reserve the right to call for the above report at any stage of acceptance inspection, before and after acceptance testing.

2. Mean, standard deviation, range and minimum values of the following characteristics shall be reported for the period of report mentioned in para 1.3.

- Composition (raw elastomeric and ash content)
- Hardness
- Tensile strength
- Elongation at break
- Compression set
- Accelerated ageing
- Shear modulus

3. The test methods shall conform to those mentioned in Clause 918.4. of this Code.

4. The results reported shall be based on random sampling. In case of more than one test measurement of any characteristics from a single batch, their mean value shall only be taken into account as representative of the batch.

The test results reported shall represent a grand lot comprising not less than 50 separate inspection lots.

5. Results of ozone resistance tests according to Clause 915.2.3. and frequency of testing shall be reported.

Results of any other control tests conducted on moulded samples of finished bearings may also be reported.