



RC : 21-2000

**STANDARD SPECIFICATIONS  
AND  
CODE OF PRACTICE  
FOR  
ROAD BRIDGES**

**SECTION: III  
CEMENT CONCRETE (PLAIN AND REINFORCED)**  
*(Third Revision)*



**THE INDIAN ROADS CONGRESS  
2000**

*Antuapri*  
21/6

IRC : 21-2000

**STANDARD SPECIFICATIONS  
AND  
CODE OF PRACTICE  
FOR  
ROAD BRIDGES**

**SECTION: III  
CEMENT CONCRETE (PLAIN AND REINFORCED)**  
*(Third Revision)*

*Published by*  
**THE INDIAN ROADS CONGRESS**  
**Jamnagar House, Shahjahan Road,**  
**New Delhi-110011**  
**2000**

*Price Rs.160/-*  
**(Plus packing & postage)**

First published	: October, 1966	
Reprinted	: January, 1969	
First Revision	: March, 1972	(Incorporates Amendment No.1-Nov.1971)
Reprinted	: July, 1974	(Incorporates Amendments No.2-Dec.1972, No.3-Nov.1973 and No.4-April, 1974)
Reprinted	: April, 1977	(Incorporates Amendment No.5-April, 1976)
Reprinted	: June, 1980	(Incorporates Amendment No.6-May, 1977)
Reprinted	: March, 1983	(Incorporates Amendments No.7-September 1981 and No.8-December 1982, modification of Clause No. 303.5, changes in Notations and units as per IRC:71)
Second Revision	: March, 1987	
Reprinted	: August, 1988	
Reprinted	: September, 1994	(Incorporates Amendment to Clause 304.7.1.1 Errata and Amendment Nos. I to Second Revision)
Reprinted	: November, 1996	
Reprinted	: December, 1997	
Third Revision	: October, 2000	

*(Rights of Publication and of Translation are reserved)*

## CEMENT CONCRETE (PLAIN AND REINFORCED)

### CONTENTS

	<i>Page No.</i>
Composition of Bridge Specifications & Standards Committee	(i) to (ii)
Notations	(iii) to (v)
Clause No.	
Introduction	1
300 Scope	2
301 Terminology	3
302 Materials	4
303 Basic Permissible Stresses	18
304 General Design Requirements	20
305 Beams and Slabs	43
306 Columns and Compression Members	58
307 Footing or Bases	65
308 Balanced Cantilever and Continuous Construction	69
309 Box Girders	70
310 Workmanship	71
Appendix 1 : Design Surface Crack Width	79

## MEMBERS OF THE BRIDGE SPECIFICATIONS AND STANDARDS COMMITTEE

(As on 7.12.99)

- |     |   |  |
|-----|---|--|
| 1.  | Prafulla Kumar*<br>(Convenor)                   | DG(RD) & Addl. Secretary, Ministry of Surface Transport<br>(Roads Wing), Transport Bhawan, New Delhi-110001                          |
| 2.  | The Chief Engineer(B)<br>S&R (Member-Secretary) | (V. Velayutham), Ministry of Surface Transport<br>(Roads Wing), Transport Bhawan, New Delhi-110001                                   |
| 3.  | S.S. Chakraborty                                | Managing Director, Consulting Engg. Services (I) Ltd., 57,<br>Nehru Place, New Delhi-110019  |
| 4.  | Dr. M.G. Tamhankar                              | Emeritus Scientist, Structural Engg. Res. Centre, 399, Pocket<br>E, Mayur Vihar Phase II, Delhi-110091                               |
| 5.  | Ninan Koshi                                     | DG(RD) & Addl. Secretary (Retd.), 56, Nalanda Apartments,<br>Vikasपुरी, New Delhi  |
| 6.  | A.G. Borkar                                     | Technical Adviser to Metropolitan Commr., A-I, Susnehi Plot<br>No. 22, Arun Kumar Vaidya Nagar, Bandra Reclamation,<br>Mumbai-400050 |
| 7.  | N.K. Sinha                                      | Chief Engineer (PIC), Ministry of Surface Transport (Roads<br>Wing), Transport Bhawan, New Delhi-110001                              |
| 8.  | M.V.B: Rao                                      | Head, Bridge Division, Central Road Research Institute, P.O.<br>CRRI, New Delhi-110020   |
| 9.  | C.R. Alimchandani                               | Chairman & Managing Director (STUP Consultants Ltd.,<br>1004-5, Raheja Chambers, 213, Nariman Point, Mumbai-<br>400021               |
| 10. | Dr. S.K. Thakkar                                | Professor, Department of Earthquake Engg., University of<br>Roorkee, Roorkee-247667  |
| 11. | M.K. Bhagwagar                                  | Consulting Engineer, Engg. Consultants (P) Ltd., F-14/15,<br>Connaught Place, New Delhi-110001                                       |
| 12. | P.D. Wani                                       | Member, Maharashtra Public Service Commission, Bank of<br>India Building, Mumbai-400025  |
| 13. | S.A. Reddi                                      | Dy. Managing Director, Gammon India Ltd., Gammon House,<br>Prabhadevi, Mumbai-400025   |
| 14. | Vijay Kumar                                     | Managing Director, UP State Bridge Corporation Ltd., Setu<br>Bhavan, 16, Madan Mohan Malviya Marg, Lucknow-226001                    |
| 15. | C.V. Kand                                       | Consultant, E-2/136, Mahavir Nagar, Bhopal-462016  |
| 16. | M.K. Mukherjee                                  | 40/182, C.R. Park, New Delhi-110019  |
| 17. | Mahesh Tandon                                   | Managing Director, Tandon Consultants (P) Ltd., 17, Link<br>Road, Jangpura, Extn., New Delhi   |
| 18. | Dr. T.N. Subba Rao                              | Chairman, Construma Consultancy (P) Ltd., 2nd Floor, Pinky<br>Plaza, Mumbai-400052   |
| 19. | A.K. Harit                                      | Executive Director (B&S), Research Designs & Standards<br>Organisation, Lucknow-226001   |
| 20. | A.D. Narain                                     | Director General (Road Development) & Addl. Secy., MOST<br>(Retd.), B-186, Sector 26, NOIDA  |
| 21. | V.R. Jayadas                                    | Chief Engineer, Dy. Director General (B), DGBR, Seema<br>Sadak Bhavan, Delhi Cantt., Naraina, New Delhi-66                           |
| 22. | P.C. Bhasin                                     | 324, Mandakini Enclave, Alkananda, New Delhi-110019  |

\*ADG(B) being not in position. The meeting was presided by Shri Prafulla Kumar, Director General (Road Development) and Addl. Secretary, Ministry of Surface Transport.

## IRC : 21-2000

23. P.K. Sarmah Chief Engineer, PWD (Roads) Assam, P.O. Chandmari, Guwahati-781003
24. S.R. Tambe Secretary, Maharashtra PWD (Retd.), 72, Pranit J. Palkar Marg, Opp. Podar Hospital, Worli, Mumbai-400025
25. The Secretary to the Govt. of Gujarat (H.P. Jamdar) R&B Department, Block No. 14, New Sachivalaya, 2nd Floor, Gandhinagar-382010
26. The Chief Engineer (R&B) (D. Sree Rama Murthy), National Highways, Irrum Manzil, Hyderabad-500482
27. The Chief Engineer(NH) (D. Guha), Public Works Department, Writers' Building, Block C, Calcutta-700001
28. The Engineer-in-Chief (R.R. Sheoran), Haryana P.W.D., B&R, Sector-19 B, Chandigarh-160019
29. The Director General (Works) Central Public Works Department, Nirman Bhawan, New Delhi
30. The Chief Engineer Ministry of Surface Transport (Roads Wing), New Delhi
31. The Chief Engineer (R) S&R (C.C. Bhattacharya), Ministry of Surface Transport (Roads Wing), Transport Bhawan, New Delhi
32. The Director Highways Research Station, 76 Sarthat Patel Road, Chennai-600025.
33. The Director & Head Bureau of Indian Standards, Manak Bhawan, 9, Bahadurshah Zafar Marg, New Delhi-110002
34. The Chief Engineer (NH) M.P. Public Works Department, Bhopal-461004
35. The Chief Engineer (NH) U.P. P.W.D., Lucknow
36. The Chief Engineer (NH) Punjab PWD, B&R Branch, Patiala

**Ex-Officio Members**

37. President K.B. Rajoria  
Indian Roads Congress Engineer-in-Chief, Delhi, PWD, New Delhi
38. Director General Prafulla Kumar,  
(Road Development) DG(RD) & Addl. Secretary to the Govt. of India, Ministry of Surface Transport (Roads Wing), Transport Bhawan, New Delhi-110001
39. Secretary, S.C. Sharma,  
Indian Roads Congress Chief Engineer  
Ministry of Surface Transport (Roads Wing)  
Transport Bhawan, New Delhi-110001

**Corresponding Members**

1. N.V. Merani Principal Secretary (Retd.), A-47/1344, Adarsh Nagar, Worli, Mumbai-400083
2. Dr. G.P. Saha Chief Engineer, Hindustan Construction Co. Ltd., Hincan House, Lal Bahadur Shastri Marg, Vikhroli (W), Mumbai-400083
3. Shitala Sharan Advisor Consultant, Consulting Engg. Services (I) Pvt. Ltd., 57, Nehru Place, New Delhi-110019

**NOTATIONS**

$E_s$	=	modulus of Elasticity of steel
$E_c$	=	modulus of Elasticity of concrete
$l_o$	=	Basic anchorage length
$n$	=	Factor for basic anchorage length
$\phi$	=	diameter of reinforcing bars
$l_d$	=	Design anchorage length
$\alpha_1$	=	factor for reduction in anchorage length
$\alpha_2$	=	Factor for reduction in anchorage length for excess reinforcement
$A_s$	=	area of bars actually provided
$A_{sd}$	=	area of bars required at full permissible stress
$V$	=	Shift of curtailment line
$V_o$	=	Shift of curtailment line at end supports
$l_a$	=	Lap length
$R$	=	Support reaction
$h$	=	Depth of Section
$a$	=	axial spacing of the bar for calculating the lap length (cl. 304.6.6.3) or the distance of centre of gravity of the concentrated load from the nearer support (cl. 305.16.2)
$b$	=	edge distance of bar for calculation of lap length (cl. 304.6.6.3) or the breadth of the rectangular beam or slab or the breadth of the rib in case of flanged beam (cl. 304.7.1.1.1)
$V$	=	the design shear across the section
$d$	=	effective depth of the section, beam or slab
$\beta$	=	The angle between the top and bottom edges of the beam or slab of varying depth at the section considered for shear (cl. 304.7.1.1.2) or coefficient for reduction in maximum permissible stresses in long column (cl. 306.4.3) or Ratio of the long side to the short side of the footing (cl. 307.2.4)
$P$	=	axial compressive force in Newtons,
$A_g$	=	gross area of the concrete section in mm <sup>2</sup>
$\tau$	=	Design Shear Stress at any cross section
$\tau_{max}$	=	Maximum permissible Shear Stress
$A_{sw}$	=	total cross-sectional area of stirrup legs or bent up bars within a distances

Bharadwaj

IRC : 21-2000

IRC : 21-2000

$s$	=	spacing of the stirrups or bent-up bars along the length of the member
$\sigma_s$	=	permissible tensile stress in shear reinforcement
$\alpha$	=	angle between the inclined stirrup or bent up bar and the axis of the member, not less than 45° or (cl.307.1.4) or constant for calculation of effective width (cl.305.16.2) or modular ratio (cl. 306.5.2)
$V_e$	=	equivalent shear
$T$	=	torsional moment
$M$	=	bending moment at the cross-section
$M_t$	=	equivalent Bending Moment due to torsion
$D$	=	the overall depth of the beam
$A_{swl}$	=	cross-sectional area of bar forming the closed hoop
$b_1$	=	centre to centre distance between corner bars in the direction of the width
$d_1$	=	centre to centre distance between corner bars in the direction of the depth
$\tau_e$	=	equivalent shear stress
$\tau_c$	=	shear strength of the concrete
$l_o$	=	effective span (cl. 305.4) or the unsupported length of the compression flange (cl.305.9), or the distance between points of zero moments (cl. 305.15.2)
$l$	=	distance between centre of supports Clause 305.15.2 or effective length of column (cl. 306.4.3)
$l_1$	=	clear span
$d$	=	effective depth of beam or slab
$b_e$	=	effective width for compression flange
$b_w$	=	thickness of the web for beams (for T-beam and slab) or thickness of the webs + width of the slab between webs (for hollow box sections)
$b_{ef}$	=	the effective width of slab on which the load acts
$b_l$	=	the breadth of concentration area of the load for calculation of effective width
$\sigma_c$	=	the permissible stress in direct compression for concrete
$\sigma_{sc}$	=	the permissible stress in direct compression for the longitudinal steel
$A_c$	=	the cross-sectional area of concrete exclusive of any finishing material applied after the casting of the column

$A_s$	=	the cross-sectional area of the longitudinal steel in columns or area of the tension reinforcement
$A_{co}$	=	the cross-sectional area of concrete in the column core, excluding the area of longitudinal steel
$A_{sp}$	=	the equivalent area of helical reinforcement
$\sigma_{sp}$	=	Tension in helical reinforcement
$r$	=	the least radius of gyration
$N$	=	the permissible axial load on the column
$W$	=	the section modulus
$\sigma_c, cal$	=	the calculated direct compressive stress
$\sigma_c, cal$	=	the calculated compressive bending stress
$\sigma_c$	=	the permissible flexural compressive stress
$A_1$	=	dispersed concentric area which is geometrically similar to the loaded area $A_2$
$A_2$	=	loaded area
$c_{min}$	=	is the minimum cover to the tension steel
$\sigma_{cr}$	=	is the perpendicular distance from the point considered to the surface of the nearest longitudinal bar
$\epsilon_m$	=	is the average strain at the level where cracking is being considered calculated allowing for the stiffening effect of the concrete in the tension zone
$b_1$	=	is the width of the section at the centroid of the tension steel
$a$	=	is the distance from the compression face to the point at which the crack width is being calculated
$\epsilon_1$	=	is the average strain at the level where cracking is being considered, calculated ignoring the stiffening effect of the concrete in the tension zone
$x$	=	is the depth of the neutral axis found from the analysis to determine $e_1$
$f_y$	=	characteristics strength of untempered steel in N/mm <sup>2</sup>

**CEMENT CONCRETE (PLAIN AND REINFORCED)****INTRODUCTION**

The Standard Specifications and Code of Practice for Road Bridges, Section III - Cement Concrete (Plain and Reinforced) was first published in October, 1966. To cater for the technological developments which were taking place in course of time, the Code was examined by the Technical Committees of the IRC and revised in 1972 and in 1987 in the light of their recommendations.

In the light of further developments in the field of plain and reinforced concrete, the provisions of the Code were reviewed by the Committee for Reinforced, Prestressed and Composite Concrete (B-6) consisting of the following personnel:

Ninan Koshi	..	<i>Convenor</i>
A.N. Dhodapkar	..	<i>Member-Secretary</i>

**MEMBERS**

N.K. Sinha	Jose Kurien
S.G. Joglekar	P.Y. Manjure
Dr. T.N. Subba Rao	A.S. Prasada Rao
M.K. Mukherjee	R.A. Chaudhary
Dr. M.G. Tamhankar	G.R. Haridas
Shitala Sharan	D.D. Sharma
Mahesh Tandon	Director & Head, Civil Engg., Bureau of Indian Standard,
S.A. Reddi	(Vinod Kumar)
Ashok K. Basa	

T. Viswanathan

**EX-OFFICIO MEMBERS**

President, IRC (K.B. Rajoria)	DG(RD) (Prafulla Kumar)
	Secretary, IRC (S.C. Sharma)

**CORRESPONDING MEMBER**

P.S. Tyagi

The amendments as finalised by this Committee were considered and approved by the Bridge Specifications and Standards Committee in their meeting held at New Delhi on 7th December, 1999 and later approved by the Executive Committee in their meeting held at New Delhi on 14th December, 1999. The draft amendments were discussed and approved by the Council of the Indian Roads Congress at the 157th Council Meeting held at Madurai on 4th January, 2000.

It was also decided that the document would be published as a fully revised Code after incorporating all the amendments.

The object of issuing the Standard Specifications and Code of Practice for Road Bridges Section III-Cement Concrete (Plain and Reinforced) is to establish a common procedure for the design and construction of road bridges in India. The publication is meant to serve as a guide to both the design engineers and the construction engineers but compliance with the provisions therein does not relieve them in any way of the responsibility for the stability, soundness and safety of the structures designed and erected by them.

The design and construction of road bridges require an extensive and thorough knowledge of science and technique involved and should be entrusted only to specially qualified engineers with adequate experience of bridge engineering, capable of ensuring careful execution of work.

### 300. SCOPE

This Code deals with the structural use of plain cement concrete and reinforced cement concrete in road bridges.

### 301. TERMINOLOGY

For the purpose of this Code, the following definitions shall apply:

#### 301.1. Concrete

A mixture of cement, water, fine and coarse aggregates and any admixture (that may be permitted by the competent authority) prepared and placed in accordance with this Code.

301.1.1. **Reinforced concrete** : Concrete containing steel reinforcement (non-prestressed) conforming to Clause 302.5 of this Code and of no less than the minimum amount required by this Code and is a composite material in which both materials act in co-operation to resist the stress resultants.

(Concrete containing prestressed steel reinforcement for introducing precompression of tensile flange of element is termed Prestressed Concrete which is outside the purview of this Code).

301.1.2. **Plain concrete** : Concrete containing no steel reinforcement or less amount of reinforcement than specified for reinforced concrete in this Code, the co-operation of such steel being ignored in resisting stress resultants.

(Plain concrete cast in such massive dimensions as to require specific measures to be taken to cater for generation of heat and attendant volume change to minimise cracking is termed Mass Concrete which is outside the purview of this Code).

301.2. **Core of Helically Reinforced Column** : The portion of the concrete enclosed within the outer surface formed by the helical reinforcement.

301.3. **Curing Concrete** : Maintaining moisture condition to promote continued hydration of cement in the concrete.



301.4. **Effective Depth of a Beam** : The distance between the centroid of the area of tension reinforcement and the fibre at which the compressive stress is maximum.

301.5. **Mortar** : A mixture of cement, fine aggregate and water and any admixture that may be permitted by the competent authority.

301.6. **Cover** : The thickness from the outer surface of the concrete to the nearest surface of the reinforcement.

### 302. MATERIALS

#### 302.1. Cement

Any of the following types of cement may be used with prior approval of competent authority.

Table 1

Type	Conforming to
(i) Ordinary Portland Cement 33 Grade	IS: 269
(ii) Ordinary Portland Cement 43 Grade	IS: 8112
(iii) Ordinary Portland Cement 53 Grade	IS: 12269
(iv) Rapid Hardening Portland Cement	IS: 8041
(v) Sulphate Resistant Portland Cement	IS: 12330
(vi) Portland Pozzolana Cement	IS: 1489-Part-I
(vii) Portland Blast Furnace Slag Cement	IS: 455
(viii) Low Heat Portland Cement	IS: 12600

Notes : (1) Use of Portland pozzolana cement may be permitted only in plain concrete members.

(2) Under severe condition of sulphate content in subsoil water, special literature on precautions to be taken with regard to the use of special types of cement with low  $C_3A$  content may be referred to. Durability criteria like minimum cement content and water cement ratio, etc. should also be given due consideration.

#### 302.2. Admixtures

To improve workability of concrete, admixtures, conforming to IS:9103 may be used.

#### 302.3. Aggregates

302.3.1. **General** : All coarse and fine aggregates shall conform to IS:383 and shall be tested to conform to IS:2386 Parts I to VIII.

##### 302.3.2. Coarse aggregate

302.3.2.1. Coarse aggregates shall consist of clean, hard, strong, dense, non-porous and durable pieces of crushed stone, crushed gravel, natural gravel or a suitable combination thereof or other approved inert material.

302.3.2.2. The maximum size of the coarse aggregate may be as large as possible within the limits specified, but in no case greater than one quarter of the minimum thickness of member or 10 mm less than the minimum lateral clear distance between individual reinforcements or 10 mm less than the minimum clear cover to any reinforcement.

302.3.2.3. The preferred nominal size of aggregate is 20 mm for reinforced concrete and prestressed concrete. However, larger sizes upto 40 mm may be permitted in special cases when there is no restriction to flow of concrete in a section.

For plain concrete, preferred nominal sizes may be between 20 mm and 40 mm. However, larger sizes may be permitted only in special cases, subject to supplemental specifications and precautions.

302.3.3. **Fine aggregates** : Fine aggregates shall consist of hard, strong, durable clean particles of natural sand, crushed

stone or gravel or suitable combination of natural sand and crushed stone or gravel. They shall not contain dust, lumps, soft or flaky particles, mica and other deleterious materials in such quantities as would reduce the strength or durability of concrete or attack the reinforcement.

302.3.4. Grading of aggregates shall be such as to produce a dense concrete of the specified strength, which can be worked readily into position without segregation and without the use of excessive water content.

#### 302.4. Water

Water used for mixing and curing shall be clean and free from injurious amounts of oils, acids, alkalis, salts, sugar, organic materials or other substances that may be deleterious to concrete or steel.

302.4.1. In case of doubt regarding development of strength, the suitability of water for making concrete shall be ascertained by the compressive strength and initial setting time tests specified in 302.4.1.2. and 302.4.1.3.

302.4.1.1. The sample of water taken for testing shall represent the water proposed to be used for concreting, due account being paid to seasonal variation. The sample shall not receive any treatment before testing other than that envisaged in the regular supply of water proposed for use in concrete. The sample shall be stored in a clean container previously rinsed out with similar water.

302.4.1.2. Average 28 days compressive strength of at least three 150 mm concrete cubes prepared with water proposed to be used shall not be less than 90 per cent of the average of strength of three similar concrete cubes prepared with distilled water. The cubes shall be prepared, cured and

tested in accordance with the requirements of IS:516.

302.4.1.3. The initial setting time of test block made with the appropriate cement and the water proposed to be used shall not be less than 30 minutes and shall not be more than 30 minutes from the initial setting time of control test block prepared with the same cement and distilled water. The test blocks shall be prepared and tested in accordance with the requirements of IS:4031 (Part 5).

302.4.2. The pH value of water shall not be less than 6. Potable water is generally considered satisfactory for mixing concrete. As a guide the following concentrations represent the maximum permissible values :

- (a) To neutralise 100 ml sample of water, using phenolphthalein as an indicator, it should not require more than 5 ml of 0.02 normal NaOH. The details of test are given in 8.1 of IS:3025 (Part 22).
- (b) To neutralise 100 ml sample of water, using mixed indicator, it should not require more than 25 ml of 0.02 normal H<sub>2</sub>SO<sub>4</sub>. The details of test shall be as given in Clause 8 of IS:3025 (Part 23).
- (c) Permissible limits for solids shall be as given in Table 2.

**Table 2. Permissible Limit for Solids**

	Tested as per	Permissible limit max.
Organic	IS:3025 (Pt. 18)	200 mg/lit.
Inorganic	IS:3025 (Pt. 18)	3000 mg/lit.
Sulphates (as SO <sub>4</sub> )	IS:3025 (Pt. 28)	400 mg/lit.
Chlorides (as Cl)	IS:3025 (Pt. 32)	2000 mg/lit.
		for concrete work not containing embedded steel and 500 mg/lit. for prestressed/reinforced concrete work
Suspended matter	IS:3025 (Pt. 17)	2000 mg/lit.

302.4.3. Mixing or curing of concrete with sea water is not permitted because of presence of harmful salts in sea water.

302.4.4. Water found satisfactory for mixing is also suitable for curing concrete. However, water used for curing should not produce any objectionable stain or unsightly deposit on the concrete surface. The presence of tannic acid or iron compounds is objectionable.

### 302.5. Reinforcement

Reinforcement shall consist of the following grades of reinforcing bars, designated by their characteristic strength, where characteristic strength  $f_y$  shall be taken as that specified in governing IS Specifications listed in Table 3 as the minimum value of 0.2 per cent proof stress or yield stress.

Table 3

Grade designation	Bar type conforming to governing IS specifications	Characteristic strength $f_y$ MPa	Elastic modulus GPa
Fe 240	IS:432 Part I Mild steel	240	200
Fe 415	IS:1786 Deformed bar	415	200
Fe 500	IS:1786 Deformed bar	500	200

Note: Wire fabrics conforming to IS:1566 and TMT bars conforming to IS:1786 can also be used.

### 302.6. Concrete

302.6.1. **Concrete grade** : The concrete shall be in grades designated in Table 4, where the characteristic strength is defined as the strength of material below which not more than 5 per cent of test results are expected to fall :

Table 4

Grade designation	Specified characteristic compressive strength of 150 mm cubes at 28 days (MPa)
M 15	15
M 20	20
M 25	25
M 30	30
M 35	35
M 40	40
M 45	45
M 50	50
M 55	55

302.6.2. Minimum concrete grade, minimum cement content and maximum water cement ratio for structural members under different conditions of exposure are given in Table 5.

302.6.3. The cement content shall not exceed 540 kg/m<sup>3</sup> of concrete.

302.6.4. Total water soluble sulphate (SO<sub>3</sub>) content of the concrete mix expressed as (SO<sub>3</sub>) shall not exceed 4 per cent by mass of cement used in the mix.

302.6.5. Total chloride content in concrete expressed as chloride-ion shall not exceed the following values by mass of

**Table 5**

**A) FOR BRIDGES IN PRESTRESSED CONCRETE OR THOSE WITH TOTAL LENGTH MORE THAN 60 M OR THOSE THAT ARE BUILT WITH INNOVATIVE DESIGN/CONSTRUCTION**

STRUCTURAL MEMBER	MINIMUM GRADE OF CONCRETE CONDITIONS OF EXPOSURE		MIN. CEMENT CONTENT FOR ALL EXPOSURE CONDITIONS (kg./cu.m)	MAXIMUM WATER CEMENT RATIO CONDITIONS OF EXPOSURE	
	Moderate	Severe		Moderate	Severe
a) PCC members	M25	M30	360	0.45	0.45
b) RCC members	M30	M35	380	0.45	0.40
c) PSC members	M35	M40	400	0.40	0.40

**B) FOR BRIDGES OTHER THAN THOSE MENTIONED IN TABLE A, FOR CULVERTS AND OTHER INCIDENTAL CONSTRUCTION**

STRUCTURAL MEMBER	MINIMUM GRADE OF CONCRETE CONDITIONS OF EXPOSURE		MIN. CEMENT CONTENT (Kg./cu.m.)	MAXIMUM WATER CEMENT RATIO CONDITIONS OF EXPOSURE	
	Moderate	Severe		Moderate	Severe
a) PCC members	M15	M20	250	0.50	0.45
b) RCC members	M20	M25	310	0.45	0.40

Notes :- (1) Conditions of exposure :

**Severe** - Marine environment: alternate wetting and drying due to sea spray; alternate wetting and drying combined with freezing; buried in soil (having corrosive effect); members in contact with water where the velocity of flow and the bed material are likely to cause erosion of concrete.

**Moderate** - conditions other than 'severe'.

(2) The minimum cement content is based on 20 mm size aggregates. For larger size aggregates, it may be reduced suitably by not more than 10 per cent. Similarly for smaller size aggregates, it may be suitably increased, but not more than 10 per cent.

cement used :

Type	Per cent
PSC	0.10
R.C.C. (in severe condition of exposure)	0.20
R.C.C. (in moderate condition of exposure) and P.C.C.	0.30

**302.7. Requirement for Design Mixes**

**302.7.1. Target mean strength :** The target mean strength of specimen shall exceed the specified characteristic strength by at least the current margin :

- (i) The current margin for a concrete mix shall be determined and shall be taken as 1.64 times the standard deviation of sample test results taken from at least 40 separate batches of concrete of nominally similar proportions produced at site by the same plant under similar supervision, over a period exceeding 5 days, but not exceeding 6 months.
- (ii) Where there are insufficient data to satisfy the above, the current margin for the initial mix design shall be taken as given in Table 6.

**Table 6**

Concrete Grade	Current Margin (MPa)	Target Mean Strength (MPa)
M 15	10	25
M 20	10	30
M 25	11	36
M 30	12	42
M 35	12	47
M 40	12	52
M 45	13	58
M 50	13	63
M 55	14	69
M 60	14	74

This initial current margin, given in Table 6, shall be used only until sufficient data are available to determine the current margin as per sub-clause (i) above.

**302.7.2. Suitability of proposed mix proportions :** Following information shall be furnished for deciding suitability of proposed mix proportions

- (a) Nature and source of each material
- (b) the quantities of each material per cubic metre of fully compacted concrete
- (c) either of the following
  - (i) appropriate existing data as evidence of satisfactory previous performance for target mean strength, current margin, workability and water/cement ratio and any other additional requirement(s) as specified.
  - (ii) full details of tests on trial mixes carried out in accordance with sub-clause 302.7.3 or
  - (iii) for ordinary structural concrete, a statement that, for initial production, the appropriate mix proportions given in Table 7 will be used.

**Table 7. Proportions for Nominal Mix Concrete**

Concrete Grade	Total quantity of dry aggregate by mass per 50 kg of cement to be taken as the sum of individual masses of fine and coarse aggregate (Kg)	Proportion of fine aggregate to coarse aggregate (by mass)	Maximum quantity of water per 50 kg of cement (Litres)	
			P.C.C.	R.C.C.
M15	350	Generally 1:2, subject to upper limit 1:1.5 and lower limit 1:2.5	25	-
M20	250		25	22

**302.7.3. Trial mixes :** Trial mixes shall be prepared using samples of approved materials for all grades of concrete.

Sampling and testing procedures shall be in accordance with Clauses 302.10 and 302.11.

The concreting plant and means of transportation employed to make the trial mixes and to transport them to representative distances shall be similar to the corresponding plant and transport to be used in the works. A clean dry mixer shall be used and the first batches shall be discarded. Test cubes shall be taken for trial mixes as follows. For each mix, set of six cubes shall be made from each of three consecutive batches. Three from each set of six shall be tested at an age of 28 days and three at an earlier age approved by the engineer-in-charge. The cubes shall be made, cured, stored, transported and tested in compression in accordance with the specification.

The average strength of the nine cubes at 28 days shall exceed the specified characteristic strength by the current margin minus 3.5 MPa.

**302.7.4. Additional trial mixes :** Additional trial mixes and tests, shall be carried out during production before substantial changes are made in the material or in the proportions of the materials to be used, except when adjustments to the mix proportions are carried out in accordance with 302.9.2.1.

### 302.8. Requirement for Nominal Mix Concrete

Unless otherwise specified, the nominal mix concrete shall be as detailed in Table 7.

### 302.9. Production of Concrete

**302.9.1. Batching and mixing :** The quantities of cement, fine aggregate and the various sizes of coarse aggregate

shall be measured by weight, unless otherwise authorised by the engineer-in-charge.

A separate weighing machine shall be provided for weighing the cement. Different types of cement shall not be mixed.

The quantity of water shall be measured. Any admixture to be added shall be measured and, if solid, shall be measured by weight.

The batch weight of aggregate shall be adjusted to allow for moisture content typical of the aggregate being used.

All measuring equipment shall be maintained in a clean and serviceable condition. Its accuracy shall be checked over the range in use when set up at each site, and maintained thereafter.

The accuracy of equipment shall fall within the following limits :

Measurement of cement	±	3 per cent of the quantity of cement in each batch.
Measurement of water	±	3 per cent of the quantity of water in each batch
Measurement of aggregate	±	3 per cent of the quantity of aggregate in each batch
Measurement of admixture	±	5 per cent of the quantity of admixture in each batch

The concrete mixer shall comply with the requirement of BIS where applicable. The mixing time shall be not less than that recommended by the manufacturer, subject to the approval of the trial mixes by the engineer-in-charge.

Concrete mixers that have been out of use for more than 30 minutes shall be thoroughly cleaned before any fresh

concrete is mixed. Unless otherwise agreed the first batch of concrete through the mixer shall then contain only two-thirds of the normal quantity of coarse aggregate. Mixing plant shall be thoroughly cleaned before changing from one type of cement to another.

### 302.9.2. Control of strength of designed mixes

**302.9.2.1. Adjustment to mix proportions :** Adjustment to mix proportions may be made in order to minimise the variability of strength subject to approval of engineer-in-charge and to maintain the target mean strength subject to approval of engineer-in-charge. Such adjustments shall not be taken to imply any change in the current margin.

**302.9.2.2. Change of current margin :** When required by the engineer-in-charge, the current margin shall be recalculated in accordance with Clause 302.7.1. The recalculated value shall be adopted as directed by the engineer-in-charge, and it shall become the current margin of concrete produced subsequently.

### 302.10. Sampling and Testing

**302.10.1. General :** Samples from fresh concrete shall be taken as per IS:1199 and cubes shall be made, cured and tested at 28 days in accordance with IS:516.

**302.10.2. Sampling procedure :** A random sampling procedure shall be adopted to ensure that each concrete batch shall have a reasonable chance of being tested, that is, the sampling should be spread over the entire period of concreting and cover all mixing units. The point and time of sampling shall be at delivery into the construction, unless otherwise agreed to.

**302.10.3. Frequency :** The minimum frequency of sampling of concrete of each grade shall be in accordance with Table 8.

Table 8

Quantity of Concrete in Work (m <sup>3</sup> )	Number of Samples
1-5	1
6-15	2
16-30	3
31-50	4
51 and above	4 plus one additional sample for each additional 50 m <sup>3</sup> or part thereof

At least one sample shall be taken from each shift of work.

302.10.4. **Test specimen and sample strength** : Three test specimens shall be made from each sample for testing at 28 days. Additional cubes may be required for various purposes such as to determine the strength of concrete at 7 days for any other purpose.

The test strength of the sample shall be the average of the strength of three specimens. The individual variation should not be more than  $\pm 15$  per cent of the average.

### 302.11. Acceptance Criteria

302.11.1. **Compressive strength** : When both the following conditions are met, the concrete complies with the specified compressive strength:

- The mean strength determined from any group of four consecutive samples should exceed the specified characteristic compressive strength by 3 MPa.
- Strength of any sample is not less than the specified characteristic compressive strength minus 3 MPa.

302.11.2. **Workability** : The concrete mix proportions chosen should be such that the concrete is of adequate

workability for placing condition of the concrete to ensure proper compaction. Suggested ranges of workability of concrete measured in accordance with IS:1195 are given below :

Degree of Workability	Slump (mm)
Low	25-50
Medium	50-100
High	100-150

302.11.3. **Chloride content** : Unless otherwise specified and agreed, the method of calculation and test shall be based upon the chloride-ion contents of all constituents and the composition of the concrete. The chloride-ion content of each of the constituent used in the calculation shall be one of the following:

- the measured value
- the value declared by the manufacturer
- the maximum value where specified in the BIS for the constituent as appropriate.

The calculated chloride content of the concrete expressed as the percentage of chloride-ion by mass of cement shall not exceed the value specified in Clause 302.6.5.

302.11.4. **Density of fresh concrete** : Where minimum density of fresh concrete is specified, the mean of any four consecutive samples shall not be less than the specified value and any individual sample result shall not be less than 97.5 per cent of the specified value.

302.11.5. **Density of hardened concrete** : Where minimum density of hardened concrete is specified, the mean of any four consecutive samples shall not less than the specified value and

IRC : 21-2000

any individual sample result shall not be less than 97.5 per cent of the specified value.

**302.12. Storage of Materials**

All efforts shall be made to store the materials in proper places so as to prevent their deterioration or intrusion by foreign matter and to ensure their satisfactory quality and fitness for the work. The storage space shall also permit easy inspection, removal and re-storage of the materials. All such materials, even though stored in approved storage, shall be subjected to acceptance test prior to their use.

**303. BASIC PERMISSIBLE STRESSES**

303.1. The permissible stresses for concrete of different grades shall be as indicated in Table 9.

**Table 9. Properties and Basic Permissible Stresses of Concrete**

Properties/permissible stresses	Concrete grade										
	M 15	M 20	M 25	M 30	M 35	M 40	M 45	M 50	M 55	M 60	
1. Modulus of elasticity Ec-design value (GPa)	26	27.5	29	30.5	31.5	32.5	33.5	35	36	37	
2. Permissible direct compressive stresses (MPa) $\sigma_{co}$ , allowable	3.75	5	6.25	7.5	8.75	10	11.25	12.5	13.75	15	
3. Permissible flexural compressive stresses (MPa) $\sigma_c$ , allowable.	5	6.67	8.33	10	11.67	13.33	15	16.67	18.3	20	

- Notes: (1) For calculating stresses in section, a modular ratio ( $E_s/E_c$ ) of 10 may be adopted.  
 (2) For design specifications of shear, bond/anchorage see Clause 304.6 and 304.7.

**303.2. Permissible Tensile and Compressive Stresses in Steel Reinforcement**

303.2.1. Permissible tensile and compressive stresses in steel reinforcement shall not exceed those given in Table 10.

**Table 10. Permissible Stresses in Reinforcing Bars**

Bar grade	Type of stress in steel reinforcement	Permissible stress in MPa
1	2	3
Fe 240	Tension in flexure, shear or combined bending	125
Fe 415		200
Fe 500		240
Fe 240	Direct compression	115
Fe 415		170
Fe 500		205
Fe 240	Tension in helical reinforcement	95
Fe 415		95
Fe 500		95

303.3. The basic permissible tensile stresses in plain concrete elements shall not exceed those given in Table 11.

**Table 11**

Concrete grade	M 15	M 20	M 25	M 30 and above
Permissible tensile stresses MPa	0.40	0.53	0.61	0.67

In case of concrete members cast in one lift with no construction joints or when special precautions are taken for surface preparation of joints like use of wet sand blasting or surface retarders, the basic values given in Table 11 can be permitted to be increased but in no case shall these exceed 1.25 times the basic value given in Table 11.



**303.4. Control of Cracking in Concrete**

303.4.1. The requirement of crack control at the tensile face of reinforced concrete components under sustained loads shall be deemed to have been satisfied, provided the following detailing criteria are met :

- (i) For slabs, the diameter and spacing of reinforcing bar shall not exceed 25 mm and 150 mm respectively.
- (ii) For beams, including top and bottom flanges in rectangular voided slab and box beams and for solid slabs in solid slab balanced cantilever bridges the diameter and spacing of reinforcing bar shall not exceed 32 mm and 150 mm respectively.
- (iii) For columns the diameter and spacing of reinforcing bar shall not exceed 32 mm and 300 mm respectively.

303.4.2. In special cases, where the detailing criteria stated in Clause 303.4.1 are not possible to be achieved, the designs shall be checked for crack width limitations as specified in *Appendix-1*.

**303.5. Permissible Stresses under various Combinations of Loads and Forces**

303.5.1. The permissible stresses given in Clause 303 shall not be exceeded for combination I of Clause 202.3 of IRC:6. The permissible increase for other combinations shall conform to Clause 203 of IRC:6.

**304. GENERAL DESIGN REQUIREMENTS****304.1. General**

304.1.1. Various stresses that are likely to occur in any plain and reinforced concrete structure, under the worst combination of loads and forces, specified in IRC:6 shall be provided for in accordance with accepted design and construction

procedure and in conformity with the fundamental principles of mechanics without exceeding the limits of stresses specified in Clause 303.

304.1.2. The detailing of reinforcement in all components shall be such as to ensure satisfactory placement and good compaction of concrete all around in the components with due consideration being given to the construction techniques adopted.

**304.2. Basis of Design**

304.2.1. The strength of a reinforced concrete structural member may be assessed by commonly employed elastic theory and it may be assumed that :

- (i) the modulus of elasticity of steel is 200 GP<sub>a</sub> unless otherwise determined by tests.
- (ii) the modular ratio has the values given in Table 9 (note 1) and
- (iii) unless otherwise permitted, the tensile strength of concrete is ignored.

304.2.2. In plain concrete structures, tension upto limits specified in Table 11 may be permitted.

**304.3. Cover**

304.3.1. The minimum clear cover to any reinforcement bar, closest to the concrete surface, shall be 40 mm.

304.3.2. Increased minimum cover thickness of 50 mm shall be provided when concrete members are exposed to severe conditions of exposure as mentioned in note (1) of Table 5 except that for the condition of alternate wetting and drying and in case of foundations where the minimum clear cover shall be 75 mm.

304.3.3. The above cover may be reduced by 5 mm for

factory made precast products with higher level of quality assurance.

#### 304.4. Bar Sizes

304.4.1. The maximum size of reinforcement shall be 40 mm diameter or a section of equivalent area, unless a bigger size is permitted by the competent authority.

304.4.2. The diameter of any reinforcing bar, including transverse ties, helicals, stirrups and all secondary reinforcement, shall generally be not less than 8 mm.

304.4.3. The diameter of longitudinal reinforcing bars in columns shall not be less than 12 mm.

304.4.4. The diameter of reinforcement in slabs shall be limited to one-tenth the depth of slab; and the diameter of shear reinforcement in beam-webs, including cranked bars, if any, shall be limited to one-eighth the thickness of the web.

#### 304.5. Distance Between Bars

304.5.1. The horizontal distance between two parallel reinforcing bars shall not be less than the greatest of the following three dimensions :

- (i) the diameter of the bar - if the diameters are equal;
- (ii) the diameter of the largest bar - if the diameters are unequal; and
- (iii) 10 mm more than the nominal size of the coarse aggregate used in concrete.

Note : In order to comply with the provisions of this sub-clause, the size of the coarse aggregate for the concrete around congested reinforcement may be reduced. This does not preclude the use of large size aggregate where the reinforcement is not congested.

304.5.2. Sufficient space shall be left between groups of bars to enable the vibrator to be inserted.

304.5.3. The minimum vertical distance between two horizontal main reinforcing bars shall be 12 mm or the maximum diameter of the coarse aggregate or the maximum size of the bar, whichever is greater.

304.5.4. When contact of bars along the lap length cannot be avoided, such bars shall preferably be grouped in the vertical plane. In no case, however, shall there be more than three bars in contact. The vertical and horizontal distances specified in the Clauses 304.5.1, 304.5.2 and 304.5.3 shall be maintained between any such group and an adjacent group or bar.

304.5.5. Subject to satisfying crack control criteria as given in Clause 303.4 the pitch of bars or wires of main tensile reinforcement in slabs shall not exceed 300 mm or twice the effective depth of the slab whichever is smaller.

304.5.6. All mesh reinforcement shall be of such dimensions as will enable the coarsest material in the concrete to pass easily through the meshes of such reinforcement.

#### 304.6. Bond, Anchorage, Splice

304.6.1. To prevent bond failure, design tension or compression in any reinforcing bar at any section of an element shall be developed on each side of the section by an appropriate anchorage length conforming to provisions given in Clause 304.6.2 or by a special anchoring device or by a combination of both.

Provided this is done, local bond stresses may be ignored.

304.6.2. Anchorage length

304.6.2.1. Permissible basic value- $l_o$  : The length required for developing full strength of bar with straight ends in tension at anchorage to keep the average bond stresses within allowable limits is termed as the basic permissible value of anchorage length  $l_o = n \phi$ .

The values of  $n$  are given in Table 12 varying with

- grade of reinforcement
- grade of concrete
- and bonding zone

Table 12. Values of  $l_o$  as Multiplies of  $\phi$

Concrete grade		$n = l_o/\phi$				
		M 20	M 25	M 30	M 35	M 40 and above
	Bar grade					
Bonding zone I (favourable)	Fe 500	66	56	48	42	42
	Fe 415	55	46	40	35	35
	Fe 240	65	60	55	50	50
Bonding zone II (unfavourable)	Fe 500	1.4 times the values given for bonding zone I				
	Fe 415					
	Fe 240					

Bonding zone II (unfavourable) shall apply to horizontal or barbed less than  $45^\circ$  and so located that more than 300 mm of fresh concrete is cast below the bar, Fig. 1.

Bonding zone I (favourable) shall apply to bar not located in bonding zone II.

304.6.2.2. Design value  $l_d$  for bars in tension

- (1) Bars in tension shall be developed either by a design anchorage length with straight ends or with end hooks of the shape

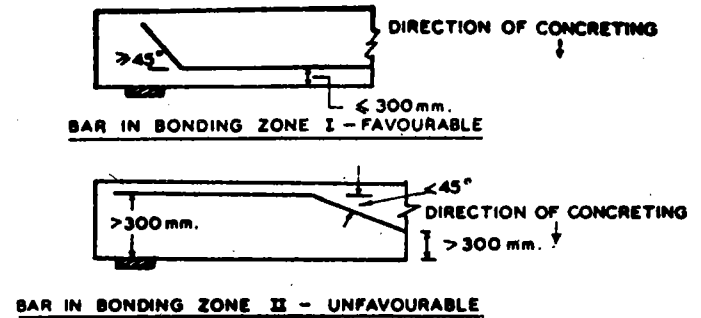
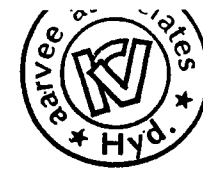

Fig. 1. Bonding zones

specified in Fig. 2. For bars of grade Fe 240 anchorage with straight ends is not permitted.

- (2) Bars developing for full tensile strength shall have design anchorage length.

$$l_d = l_{d1} = \alpha_1 l_o$$

- $\alpha_1 = 1$  for bars with straight ends  
 $= 0.7^*$  for bars with end hooks

\*applies when cover in the plane of curvature and transverse to it is not less than  $3\phi$ . With less cover,  $\alpha_1 = 1$  applies.

- (3) At sections where reinforcement area in excess of design requirement ( $A_s \geq A_{sd}$ ) has been provided a reduced length -

$$l_d = l_{d2} = \alpha_2 l_{d1}$$

shall be provided, where

$$\alpha_2 = A_{sd}/A_s \text{ with } \alpha_2 \geq 1/3$$

$\alpha_2$  (factor for excess reinforcement) =  $A_{sd}/A_s$

$A_s$  = area of bars actually provided

$A_{sd}$  = area of bars required at full permissible stress

- (4)  $l_d$  adopted shall at least be equal to  $l_a$ , min., in all cases -  $l_d \geq l_a$ , minimum

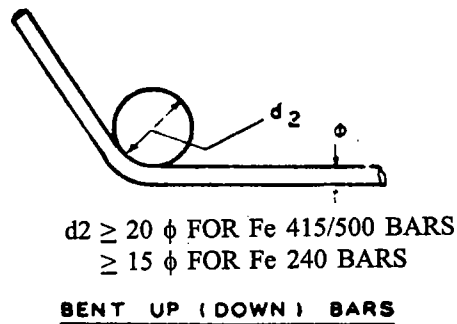
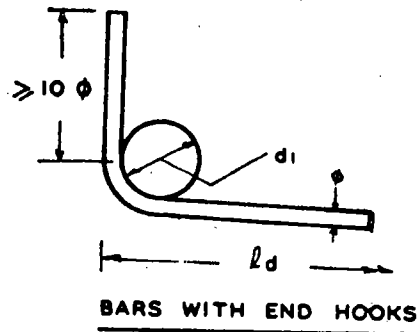
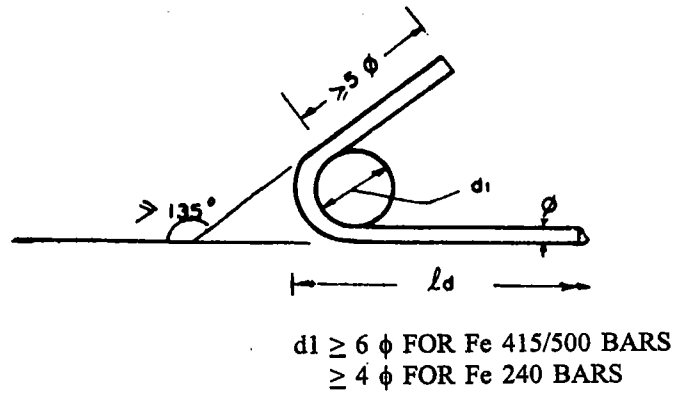

Fig. 2. Bend diameter for hooks and bent up (down) bars

for bars with straight ends

$l_d$  min. =  $12 \phi$  or 300 mm

Whichever is greater.

for bars with end hooks

$l_d$  min. =  $6 \phi$  or 150 mm

Whichever is greater.

**304.6.2.3. Design value  $l_d$  for bars in compression :** Bars in compression shall be developed by an anchorage length with straight ends, end hooks being deemed not effective and value of  $l_d$  shall be same as that specified for bars in tension in Clause 304.6.2.2.

**304.6.3. Anchorage of flexural reinforcement in beams and slabs :** The provisions of the clause shall illustrate, supplement and modify the general requirements given in Clause 304.6.2.

**304.6.3.1. Anchorage of bars over bearings :** Anchorage length of bottom bars may be reduced to 2/3 at end or at intermediate simple support to cater for the favourable effects of transverse compression. Anchorage length shall be measured from the inner (span) face of the support, Fig. 3.

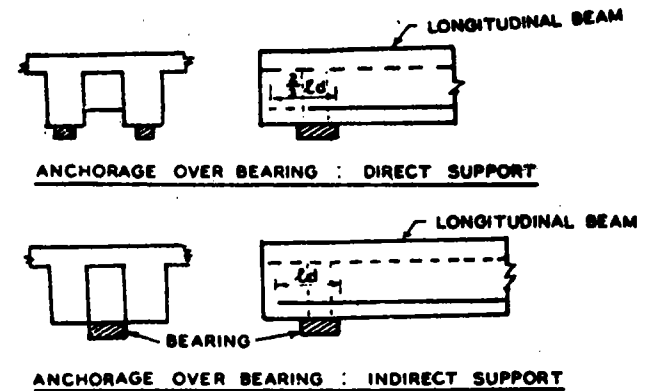

Fig. 3. Anchorage over bearings

For indirect support full  $l_d$  shall be provided.

304.6.3.2. **Anchorage of bars in tension zone** : Bars may be curtailed and anchored in the tension zone of a beam or slab when the following conditions are satisfied :

- (1) The curtailment and anchorage is done according to Fig. 4.
- (2) Curtailment of bars is optimally staggered and the area of bars curtailed satisfies the limits on continuing bars laid down in Clause 305.7.
- (3) The ends of curtailed bars are bent up at a very flat angle over the anchorage length to yield a bigger cover as shown in Fig.4.

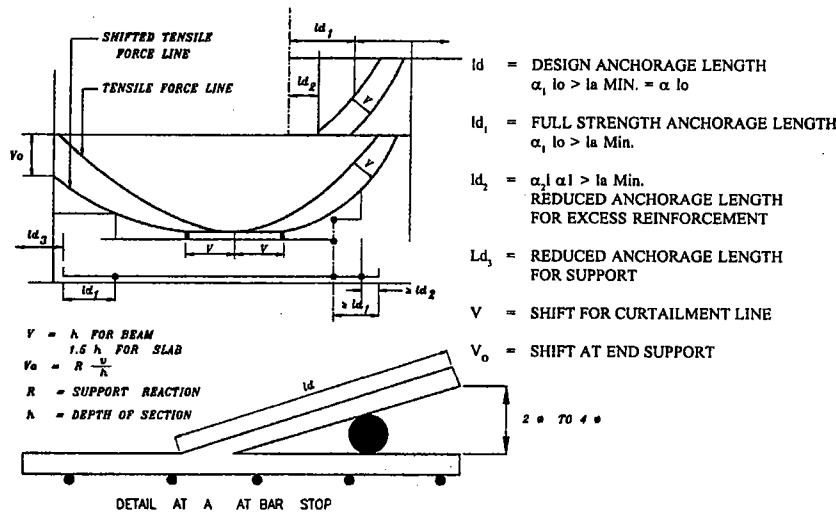

Fig. 4. Curtailment and anchorage of bars in tension zone

304.6.3.3. **Anchorage of bars bent up (down)** : Bars not required for shear resistance shall have an anchorage length  $ld$  measured from the point of bending.

Bars required for shear resistance will be continued to the opposite face of the beam/slab and anchored with a length of  $0.6$

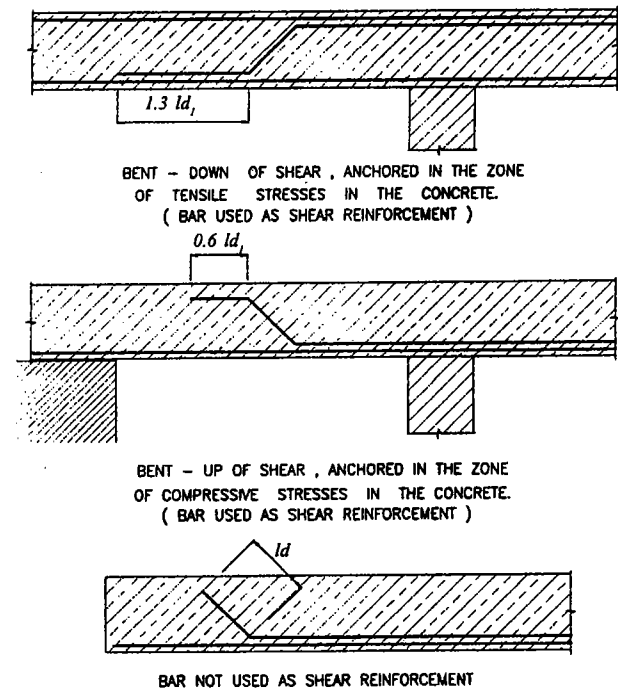

Fig. 5. Anchorage of bars bent up (down)

$ld_1$  in compression zone and  $1.3 ld_1$  in tension zone parallel to face of the beam, see Fig. 5.

304.6.4. The shear stirrups shall be deemed adequately anchored when the requirements illustrated in Fig. 6 are met with.

304.6.5. **Special anchoring device** : When the ends of a secondary reinforcement, such as stirrups or binders, are anchored in the compression zone; complete anchorage shall be notwithstanding any of the other provisions of this Code, deemed to have been provided when the end is bent round a bar of at least its own diameter through an angle of at least  $90^\circ$  and

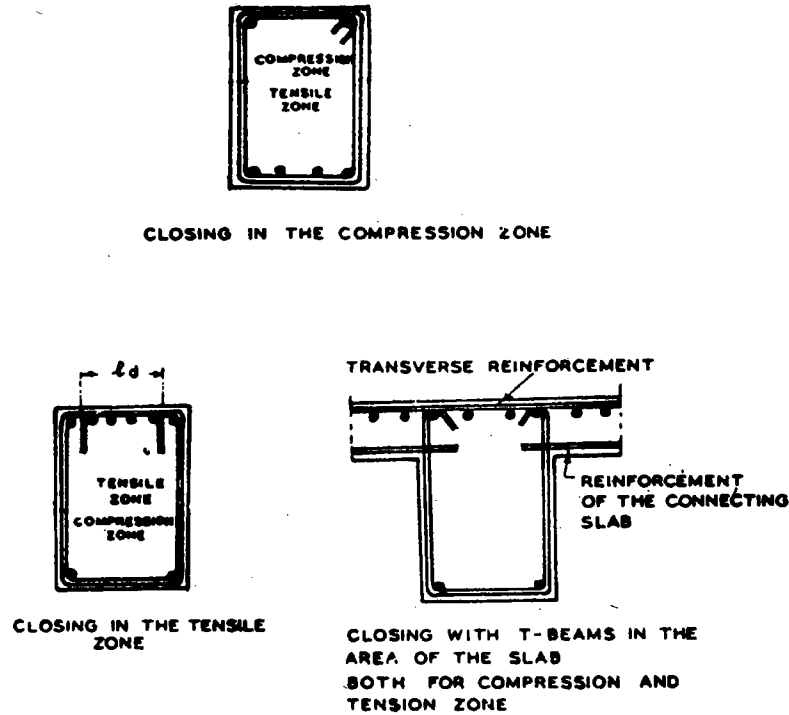

Fig. 6. Shape of stirrups

continued beyond the end of the curve for at least eight times the diameter or alternatively through an angle of at least 180° and continued beyond the end of the curve for at least four times the diameter of the bar.

304.6.6. Splices

304.6.6.1. Splices of reinforcement shall be formed by

- (1) laps of bars with straight ends or bars with end hooks
- (2) welded joints
- (3) joints with mechanical devices

304.6.6.2. Lap splices of bars in tension

- (1) Lap splices of bars in tension shall be longitudinally staggered as far as practicable. The longitudinal and transverse spacing shall conform to Fig. 7.

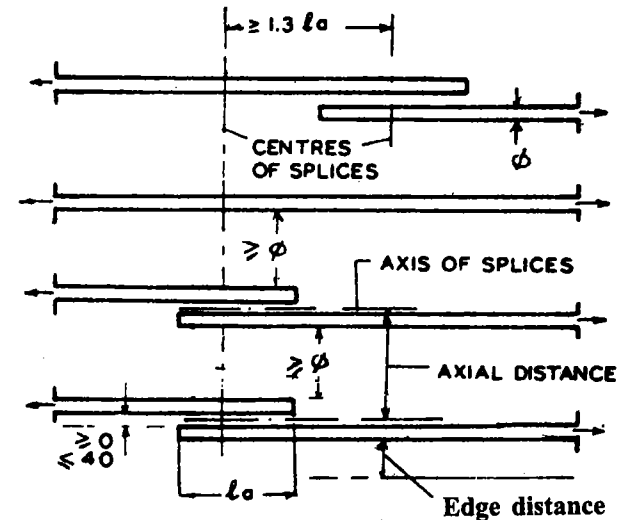

Fig. 7. Longitudinal staggering and transverse distance of reinforcing bars in the region of lap splices (dimensions in mm)

- (2) Area of bars spliced at any section shall not exceed the following proportions  $\rho$  in relation to the total area of bars provided at the section:

bar grade	$\rho$
Fe 500/415	50 per cent
Fe 240	25 per cent

In exceptional cases, 100 per cent lapping at a section may be permitted for deformed bars only, subject to special precautions and supplemental specifications.

304.6.6.3. Lap length  $l_a$

(1) the length of lap of bars in tension with straight end or with end hooks shall be  $l_a = K.l_d$  where the value of  $K$  varies with  $\rho$  as given below:

$\rho$ %	$\leq 25\%$	$> 25\%$	$> 40\%$	$> 50\%$
	$\leq 40\%$	$\leq 50\%$		
$K =$	1.4	1.6	1.8	2.2

The values of  $K$  can be reduced by 20 per cent when  $a > 10 \phi$  and/or  $b > 5 \phi$ .

Where  $a$  = axial spacing of the bar  
 $b$  = edge distance of bar shown in Fig. 7.

(2) the length of lap of bars in compression shall be equal to  $l_d$ . Hooks shall not be considered effective.

304.6.6.4. Transverse reinforcement at lap splices :  
 Minimum reinforcement in the form of stirrups shall be provided over the length conforming to the requirements shown in Fig. 8.

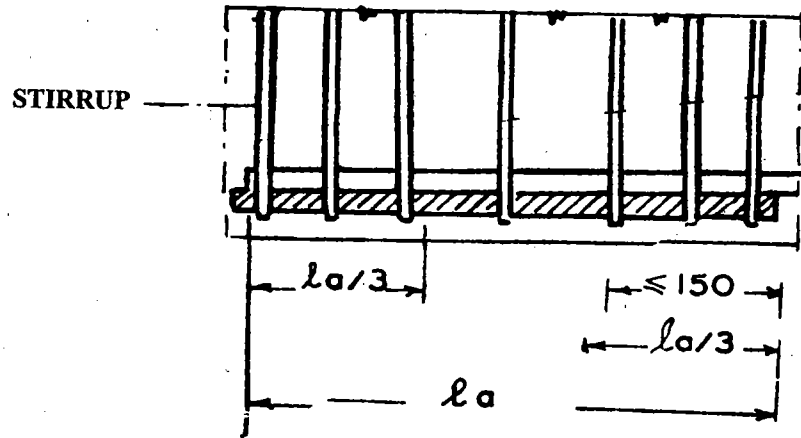

Fig. 8. Longitudinal section

304.6.6.5. Welded joints may be used subject to the following :

- (a) Welding of Fe 240 grade bars conforming to IS:432 shall be permitted. Welding of other grades of bars including Fe 500/415 grade bars conforming to IS: 1786 shall in general be prohibited except in special cases mentioned in (h) below.
- (b) Welding shall conform to IS:2751 except as provided herein.
- (c) Welding may be carried out by metal arc welding process. Oxy-acetylene welding shall not be permissible. Any other process may be used subject to the approval of the engineer and necessary additional requirements to ensure satisfactory joint performance. Precautions on over heating, choice of electrode, selection of correct current in arc welding etc., should be strictly observed.
- (d) All bars shall be butt welded except for smaller diameter bars with diameter of less than 20 mm which may be lap welded. Single-V or Double-V butt joints may generally be used. For vertical bars single bevel or double bevel butt joints may be used.
- (e) Welded joints shall be located well away from bends and not less than twice the bar diameter away from a bend.
- (f) Generally, shop welding in controlled conditions is to be preferred, where feasible. Site welding where necessary shall, however, be permitted when the facilities, equipment, process, consumables, operators, welding procedure are adequate to produce and maintain uniform quality at par with that attainable in shop welding to the satisfaction of the engineer.
- (g) Joint welding procedures which are to be employed shall invariably be established by a procedure specification and shall be qualified prior to use by tests as prescribed in IS:2751. All welders and welding operators to be employed shall have to be qualified by tests prescribed in IS:2751. Inspection of welds shall conform to IS:822 and destructive or non-destructive testing may be undertaken when deemed necessary. Joints with

weld defects detected by visual inspection or dimensional inspection shall not be accepted.

- (h) As exception to the provision of (a) above, bars of grades other than Fe 240 grade including special welding grade of Fe 500/415 grade bars conforming to IS:1786, for which necessary chemical analysis has been secured and the carbon equivalent calculated from the chemical composition using the formula

$$\text{C.E.} = C + \frac{\text{Mn}}{6} + \frac{\text{Cr+Mo+V}}{5} + \frac{\text{Ni+Cu}}{15}$$

is 0.4, or less, may be permitted to be welded. The method of welding shall conform to supplemental specifications to the satisfaction of the engineer and shall be subject to suitable qualification tests.

304.6.6.6. At the welded joints complying with Clause 304.6.6.5, while 100 per cent of the cross sectional area may be taken into account as effective for Fe 240 grade bars conforming to IS:432, only 80 per cent of such area in respect of bars other than mild steel including Fe 500/415 grade bars conforming to IS:1786 shall be considered as effective.

304.6.6.7. Bars may be joined with mechanical devices e.g. by special grade steel sleeves swaged on to bars in end to end contact or by screwed couplers.

The effectiveness of such joints shall invariably be proved by static and fatigue strength tests. Patented systems with proven use shall only be permitted to be used on production of test results showing the adequacy of the device to the satisfaction of the competent authority.

A mechanical joint including its connecting elements shall develop in tension or compression at least 125 per cent of the characteristic strength  $f_y$ .

## 304.7. Shear and Torsion

### 304.7.1. Shear

#### 304.7.1.1. Shear stress

304.7.1.1.1. The design shear stress  $\tau$  at any cross section of beams or slabs of uniform depth shall be calculated by the equation :

$$\tau = \frac{V}{b.d}$$

Where  $V$  = the design shear across the section  
 $b$  = breadth of the member, which for flanged sections shall be taken as the breadth of the web, and  
 $d$  = effective depth of the section

Note : For obtaining the maximum shear stress, the section at a distance equal to effective depth from the face of the support shall be checked and the shear reinforcement calculated at the section shall be continued up to the support.

304.7.1.1.2. In case of a beams or slabs of varying depth, the equation shall be modified as :

$$\tau = \frac{V \pm \frac{M \tan \beta}{d}}{b.d}$$

Where  $\tau$ ,  $V$ ,  $b$  and  $d$  are the same as in 304.7.1.1.1

$M$  = bending moment at the section, due to load position corresponding to shear  $V$   
 $\beta$  = angle between the top and the bottom edges of the beam at that section.

The negative sign in the formula applies when the bending moment  $M$  increases numerically in the same direction as the effective depth  $d$  increases, and the positive sign when the moment decreases numerically in this direction.



304.7.1.2. **Maximum permissible shear stress  $\tau_{max}$**  : When shear reinforcement is provided the shear  $\tau$  in beams shall not exceed stress  $\tau_{max}$ , given in Table 12A.

For slabs,  $\tau$  shall not exceed half the value of  $\tau_{max}$ , given in Table 12A.

**Table 12A. Maximum Shear Stress,  $\tau_{max}$ , N/mm<sup>2</sup>**

Concrete Grade	M20	M25	M30	M35	M40 and above
$\tau_{max}$ , N/mm <sup>2</sup>	1.8	1.9	2.2	2.3	2.5

### 304.7.1.3. Design shear strength of concrete

304.7.1.3.1. The permissible shear stress  $\tau_c$  in concrete in beams without shear reinforcement is given in Table 12B.

304.7.1.3.2. For solid slabs the permissible shear in concrete shall be  $K\tau_c$  where  $K$  has the values given in Table 12C.

304.7.1.3.3. **Shear strength of members under axial compression** : For members subjected to axial compression  $P$ , the permissible shear stress in concrete  $\tau_c$  given in Table 12B, shall be multiplied by the following factor:

$$d = 1 + \frac{5P}{A_g f_{ck}} \quad \text{but not exceeding } 1.5$$

Where  $P$  = axial compressive force in Newtons,  
 $A_g$  = gross area of the concrete section in mm<sup>2</sup>, and  
 $f_{ck}$  = characteristic compressive strength of concrete

**Table 12B. Permissible Shear Stress in Concrete**

$\frac{100 A_s}{bd}$	Permissible Shear Stress in Concrete, $\tau_c$ N/mm <sup>2</sup>				
	Grade of Concrete				
	M20	M25	M30	M35	M40
(1)	(2)	(3)	(4)	(5)	(6)
0.15	0.18	0.19	0.20	0.20	0.20
0.25	0.22	0.23	0.23	0.23	0.23
0.50	0.30	0.31	0.31	0.31	0.32
0.75	0.35	0.36	0.37	0.37	0.38
1.00	0.39	0.40	0.41	0.42	0.42
1.25	0.42	0.44	0.45	0.45	0.46
1.50	0.45	0.46	0.48	0.49	0.49
1.75	0.47	0.49	0.50	0.52	0.52
2.00	0.49	0.51	0.53	0.54	0.55
2.25	0.51	0.53	0.55	0.56	0.57
2.50	0.51	0.55	0.57	0.58	0.60
2.75	0.51	0.56	0.58	0.60	0.62
3.00 and above	0.51	0.57	0.60	0.62	0.63

Note : ' $A_s$ ' is that area of longitudinal tension reinforcement which continues at least one effective depth beyond the section being considered except at supports where the full area of tension reinforcement may be used provided the detailing conforms to Clause 304.6.

**Table 12C. Values of  $K$  for Solid Slabs**

Overall depth of slab, mm	300 or more	275	250	225	200	175	150 or less
$K$	1.00	1.05	1.10	1.15	1.20	1.25	1.30

304.7.1.4. **Members with shear reinforcement** : When  $\tau$  exceeds  $\tau_c$  given in Table 12B, shear reinforcement shall be provided in any of the following forms :

IRC : 21-2000

- a) Vertical stirrups,
- b) Bent-up bars along with stirrups, and
- c) Inclined stirrups

Where bent up bars are provided, their contribution towards shear resistance shall not be more than half that of the total shear reinforcement.

Shear reinforcement shall be provided to carry a shear  $V_s = V - \tau_c \cdot bd$ . to be calculated as below :

$$A_{sw} = \frac{V_s \cdot s}{\sigma_s \cdot d \cdot (\sin\alpha + \cos\alpha)}$$

- Where
- $A_{sw}$  = total cross-sectional area of stirrup legs or bent-up bars within  $\alpha$  distance  $s$ ,
  - $s$  = spacing of the stirrups or bent-up bars along the length of the member,
  - $b$  = breadth of the member which for flanged beams, shall be taken as the breadth of the web,
  - $\sigma_s$  = permissible tensile stress in shear reinforcement
  - $\alpha$  = angle between the inclined stirrup or bent up bar and the axis of the member, not less than  $45^\circ$ , and
  - $d$  = the effective depth

Note: Where more than one type of shear reinforcement is used to reinforce the same portion of the beam, the total shear resistance shall be computed as the sum of the resistance for the various types separately. The areas of the stirrups shall not be less than the minimum specified in 304.7.1.5.

**304.7.1.5. Minimum shear reinforcement for beams :**  
When  $\tau$  is less than  $\tau_c$  given in Table 12B, minimum shear reinforcement for beams shall be provided in accordance with

the following :

$$P_w \text{ min.} = \frac{A_{sw}}{b \cdot s} = \frac{0.4}{0.87 f_y}, f_y \leq 415 \text{ MPa}$$

304.7.1.6. Maximum spacing of stirrups shall be limited to one-half the depth of the beam subject to a maximum of 300 mm. Stirrups shall pass round, or otherwise be secured to the appropriate longitudinal tensile reinforcement. The ends of stirrups shall be adequately anchored in the compression zone in accordance with Clause 304.6.4. Where for practical purposes it is found necessary to anchor the ends of the stirrups in the tensile zone full anchorage length in accordance with Clause 304.6.2.2 shall be provided.

304.7.1.7. Bent-up bars shall be carried through a depth of at least equal to the lever arm of the resisting moment and adequately anchored in accordance with Clause 304.6.3.3. The spacing of the bent-up bar measured at the level of neutral axis and in the direction of longitudinal axis of the beam shall not exceed three-quarter the effective depth of the beam.

### 304.7.2. Torsion

304.7.2.1. **General :** In structures where torsion is required to maintain equilibrium, members shall be designed for torsion. However, for such indeterminate structures where torsion can be eliminated by releasing redundant restraints, no specific design for torsion is necessary provided torsional stiffness is neglected in the calculation of internal forces. Adequate control of any torsional cracking is provided by the shear reinforcement as per Clause 304.7.1.

Torsional reinforcement is not calculated separately for torsion alone. Instead the total longitudinal reinforcement is determined for a fictitious bending moment which is a function

of actual bending moment and torsion; similarly web reinforcement is determined for a fictitious shear which is a function of actual shear and torsion.

The design rules shall apply to beams of solid rectangular cross-section. However, these clauses may also be applied to flanged beams by substituting  $b_w$  for  $b$ , in which case they are generally conservative.

**304.7.2.2. Critical section :** Sections located less than a distance  $d$ , from the face of the support may be designed for the same torsion as computed at a distance  $d$ , where  $d$  is the effective depth.

### 304.7.2.3. Equivalent shear

304.7.2.3.1. Equivalent shear,  $V_e$ , shall be calculated from the formula :

$$V_e = V + \frac{1.6T}{b}$$

Where  $V_e$  = equivalent shear,  
 $V$  = shear,  
 $T$  = torsional moment, and  
 $b$  = breadth of beam

The equivalent nominal shear stress,  $\tau_c$ , in this case shall be calculated as given in 304.7.1.1.1. except for substituting  $V$  by  $V_e$ . The values of  $\tau_c$  shall not exceed the values of  $\tau_{max}$  given in Table 12A.

304.7.2.3.2. If the equivalent shear stress  $\tau_c$  does not exceed  $\tau_c$ , given in Table 12B, minimum shear reinforcement shall be provided as specified in 304.7.1.5.

304.7.2.3.3. If  $\tau_c$  exceeds those given in Table 12B, both

longitudinal and transverse reinforcement shall be provided in accordance with 304.7.2.4.

### 304.7.2.4. Reinforcement in members subjected to torsion

304.7.2.4.1. Reinforcement for torsion, when required shall consist of longitudinal and transverse reinforcement.

**304.7.2.4.2. Longitudinal reinforcement :** The longitudinal reinforcement shall be designed to resist an equivalent bending moment,  $M_e l$ , given by

$$M_e l = M + M_t$$

Where  $M$  = bending moment at the cross section, and

$$M_t = \frac{T(1+D/b)}{1.7}, \text{ where } T \text{ is the torsional moment,}$$

$D$  = the overall depth of the beam  
 $b$  = breadth of the beam.

304.7.2.4.2.1. If the numerical value of  $M_t$  as defined in 304.7.2.4.2. exceeds the numerical value of the moment  $M$ , longitudinal reinforcement shall be provided on the flexural compression face, such that the beam can also withstand an equivalent moment  $Me_2$  given by  $Me_2 = M_t - M$ , the moment  $Me_2$  being taken as acting in the opposite sense to the moment  $M$ .

**304.7.2.4.3. Transverse reinforcement :** Two legged closed hoops enclosing the corner longitudinal bars shall have an area of cross section  $A_{sw}$  given by

$$A_{sw} = \frac{T.s}{b_1 d_1 \sigma_s} + \frac{V.s}{2.5 d_1 \sigma_s}, \text{ but}$$

the total transverse reinforcement shall not be less than

$$\frac{(\tau_e - \tau_c) b_s}{\sigma_s}$$

Where	$T$	=	torsional moment
	$V$	=	shear force
	$A_{sw}$	=	cross sectional area of bar forming the closed hoop
	$s$	=	spacing of the stirrup reinforcement
	$b_l$	=	centre to centre distance between corner bars in the direction of the width
	$d_l$	=	centre to centre distance between corner bars in the direction of the depth
	$b$	=	breadth of the member
	$\sigma_s$	=	permissible tensile stress in shear reinforcement
	$\tau_e$	=	equivalent shear stress as specified in 304.7.2.3.1, and
	$\tau_c$	=	shear strength of the concrete as specified in Table 12B

**304.7.2.5. Distribution of torsion reinforcement :** When a member is designed for torsion, torsion reinforcement shall be provided as below :

- The transverse reinforcement shall be rectangular closed stirrups placed perpendicular to the axis of the member. The spacing of the stirrups shall not exceed the smaller of  $\frac{X_1 + Y_1}{4}$  or 300 mm. Where  $X_1$  and  $Y_1$  are respectively the short and long dimensions of the member.
- In all cases there shall be at least one longitudinal bar in each corner of the stirrups. The diameter of these longitudinal bars shall not be less than the diameter of the stirrups or 12 mm whichever is greater.

### 304.8. Moment of Inertia

**304.8.1. Moment of inertia for calculating relative stiffness :** To determine the relative stiffness of members of statically indeterminate structures, the moment of inertia may be calculated by considering :

- the entire concrete section, ignoring the reinforcement, or
- the entire concrete section, including the reinforcement on the basis of the modular ratio, or
- the compression area of the concrete section, combined with the reinforcement, on the basis of the modular ratio.

Whichever method is adopted for the beams, the same method should be used for the columns.

**304.8.2. Moment of inertia for calculating deflection:** Appropriate values of moment of inertia may be used.

### 304.9. Temperature and Shrinkage Effects

**304.9.1.** The values of co-efficients of thermal expansion and shrinkage of concrete shall be taken as follows

- |                         |   |
|-------------------------|---|
| (i) Thermal expansion   |   |
| For reinforced concrete | $117 \times 10^{-7}$ per degree celsius |
| For plain concrete      | $108 \times 10^{-7}$ per degree celsius |
| (ii) Shrinkage          | $2 \times 10^{-4}$                      |

**304.9.2.** Every simply supported span shall be provided with means to permit both rotation and longitudinal expansion caused by the design loads and forces.

### 305. BEAMS AND SLABS

**305.1.** For bridges having beam and slab type of super-structure the number of longitudinals shall not be less than

three, except for single-lane bridges and pedestrian bridges.

305.2. The minimum thickness of the deck slab including that at the tip of the cantilever shall be 200 mm. However, reduction in the thickness of the slab upto a maximum of 50 mm may be permitted at the cantilever tip subject to satisfactory detailing. The thickness of the webs shall not be less than 250 mm.

305.3. Cross girder monolithic with the deck slab shall be provided at the bearings. Intermediate cross-girders shall be provided depending on design requirements. The thickness of the cross girders shall not be less than the minimum web thickness of the main longitudinal girder. The depth of the cross girders at bearings shall be suitably adjusted to allow access for proper inspection of bearings and to facilitate positioning of jacks for future lifting up of the super-structure.

#### 305.4. Effective Span

305.4.1. In the case of free supports on line bearings, the effective span  $l_0$  shall be the distance from the centre to centre of the bearings.

305.4.2. In the case of a free support, not on line bearings, the effective span  $l_0$  shall be  $l_1 + d$  or  $l$  whichever is smaller,

- Where  $l$  = distance between centre of supports  
 $l_1$  = clear span  
 $d$  = effective depth of beam or slab.

305.4.3. In the case of restraint at the support, the effective span may be taken as equal to the clear distance between the faces of the supports.

#### 305.5. Effective Depth

305.5.1. The effective depth of a beam or slab shall be the depth from edge of the compression section to the centroid of the tension reinforcement.

305.5.2. Where haunches are provided, no portion of the haunch lying below a plane which makes a slope of 1:3, as shown in Fig. 9 shall be considered as adding to the effective depth.

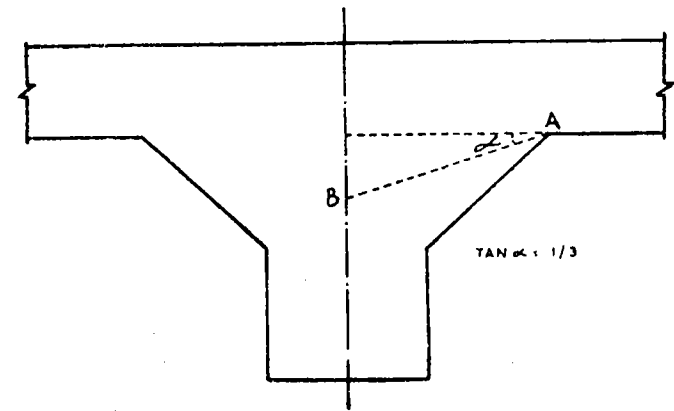

Fig. 9. Portion below line AB to be ignored for effective depth

However, for calculating the moments in a haunched slab or beam, the actual variation of moment of inertia in the span shall be considered.

305.5.3. Where member thickness varies, no portion of the member lying below or above a plane which makes a slope of 1:3 with the horizontal shall be considered as adding to the effective depth.

### 305.6 **Compression Reinforcement in Beams and Slabs**

(i) **Beams** : When in a beam, part or all of the main reinforcement is required to resist compression, links or ties atleast one quarter of the size of the largest compression bar should be provided at a maximum spacing of 12-times the size of the smallest compression bar. Links should be so arranged that every corner and alternate bar in an outer layer of reinforcement is supported by a link passing round the bar having an included angle of not more than 135°. All other bars within a compression zone shall be within 150 mm of a restrained bar.

(ii) **Slabs** : When the designed percentage of reinforcement in the compression face of a slab exceeds 1 per cent, links of atleast 6 mm or one quarter the size of the largest compression bar should be provided for a depth of 200 mm through the thickness of the slab. If the thickness of the slab is insufficient to accommodate then it should be tied with the tension bar. The spacing of these links should not exceed twice the member thickness in either of the two principal directions of the member or 400 mm and in the direction of the compression force not greater than 16 times the bar size.

#### 305.7. **Curtailment of Bars**

305.7.1. To prevent large changes in the moment of resistance the points at which the bars are curtailed shall be suitably spread.

305.7.2. In simply supported spans, at least 33 per cent of the steel required to resist the maximum bending moment shall be carried over the supports along the tension side of the beam and in the case of slab this shall not be less than 50 per

cent. For a span continuous beyond a support, at least 25 per cent of the steel required to resist the maximum positive bending moment shall be similarly carried over the support both in case of beam or slab.

#### 305.8. **Curved or Sloped Reinforcement**

Where the alignment of the reinforcement deviates from the normal to the plane of bending, as in the case of a beam with curved or sloped soffit, only the area of the reinforcement effective in the direction normal to the plane of bending shall be considered.

#### 305.9. **Lateral Support in Beams**

In flanged beams with length between adequate lateral restraints greater than thirty times the width of the compression flange, the permissible compressive stress in concrete shall be reduced by a factor equal to  $1.5 - \frac{l_o}{60b}$  where  $l_o$  is the unsupported length and  $b$  is the width of the compression flange of the beam.

#### 305.10. **Shrinkage and Temperature Reinforcement**

All faces of reinforced concrete member either fully exposed or lying within a depth of 500 mm below the level of perennial submergence under water, soil or soil-soil-water system shall be reinforced for shrinkage and temperature. This reinforcement shall be provided in two directions at right angles to each other in a plane parallel to the surface under consideration and shall be spaced at 300 mm maximum with 250 mm<sup>2</sup> of steel area per metre in each direction for all grades of reinforcement. Reinforcing bars placed near the surface of a member in each direction to carry other loads may be considered as fully

effective in providing reinforcement for shrinkage and temperature e.g. main longitudinal reinforcement, distribution reinforcement in slabs, web reinforcement in beams and ties or helicals in columns.

### 305.11. Dispersion of Live Loads on Longitudinal Beams

The dispersion of the live load along the span length through the wearing coat, deck slab and filling shall not be considered.

### 305.12. Distribution of Live Loads on Longitudinal Beams

305.12.1. When longitudinal beams are connected together by transverse members like deck slab, cross girders, diaphragms soffit slab, etc., the distribution of bending moments between longitudinals shall be calculated by one of the following methods :

- (i) Finding the reactions on the longitudinals assuming the supports of the deck slab as unyielding. This method is applicable where there are only two longitudinals with no soffit slab;
- (ii) Distributing the loads between longitudinals by Courbon's method, strictly within its limitation, i.e., when the effective width of the deck is less than half the span and when the stiffness of the cross girders is very much greater than that of the longitudinals; and
- (iii) Distributing the loads between longitudinals by any rational method of grid analysis, e.g., the method of harmonic analysis as given by Hendry and Jaeger or Morice and Little's version of the isotropic plate theory of Guyon and Massonet, etc.

305.12.2. In calculating the shear force on sections of longitudinal beams, wheel loads or track loads shall be allocated

to respective longitudinal beams by any rational method. Alternatively, the following method shall be followed :

#### (i) For loads at or within 5.5 metres of either supports

The reaction on the longitudinal beams shall be the greater of the results obtained by

- (a) assuming the deck slab simply supported or continuous as the case may be with the supports being assumed as unyielding and
- (b) following one of the three methods given in Clause 305.12.1 for the distribution of bending moments.

#### (ii) For loads more than 5.5 metres away from either supports

Distribution of the loads between the longitudinals for the purpose of finding shearing forces shall be assumed to be the same as for bending moments given in Clause 305.12.1.

### 305.13. Dispersion of Live Loads on Transverse Beams

Dispersion of live loads along the span length through the wearing coat, deck slab and filling shall not be considered.

### 305.14. Distribution of Live Loads on Intermediate Transverse Floor Beams

Distribution of loads between longitudinal beams for the purpose of finding bending moments and shears in intermediate transverse floor beams shall be made by one of the methods given in Clause 305.12.1.

### 305.15. T-Beams and L-Beams

305.15.1. For T-beams or L-beams, the slab shall be considered as an integral part of the beam if adequate bond and shear resistance are provided at the junction of the slab and the web of the beam.

305.15.2. In the absence of a more accurate determination, the effective width for compression flanges of beams with solid webs and hollow box sections shall be taken as the following, but not exceeding the actual flange width.

$$b_e = b_w + 1/5 l_o \text{ (T-beams)}$$

$$b_e = b_w + 1/10 l_o \text{ (L-beams)}$$

- Where  $b_e$  = effective width for compression flange  
 $b_w$  = thickness of the web for beams (for T-beam and slab) or thickness of the webs + width of the slab between webs (for hollow box sections).  
 $l_o$  = the distance between points of zero moments. (In the absence of elaborate calculations, for the continuous spans, it may be taken as 0.7 times the effective span).

The effective width shall be taken as constant over the entire span. In general, the effective width for tension flange may be taken as actual value.

305.15.3. If T-form or L-form is used only for the purpose of providing additional compression area, such as in continuous

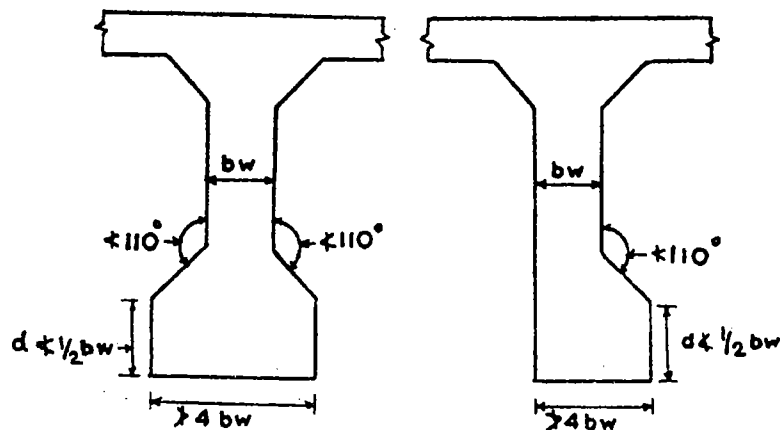

Fig. 10

beams over supports, the flange thickness shall not be less than one-half the width of the web and a total flange width not more than four times the width of the web. For effective stress transfer, it is desirable to splay the junction of the web and the flange so as to form an angle of not less than 110°, as shown in Fig. 10.

305.15.4. Where the principal reinforcement in a slab which is considered as the flange of a T-beam or L-beam is parallel to the beam, transverse reinforcement shall be provided at the top of the flange. This reinforcement shall be equal to sixty per cent of the main reinforcement of the slab at its mid-span unless it is specially calculated. The length of such reinforcing bars shall be as indicated in Fig. 11.

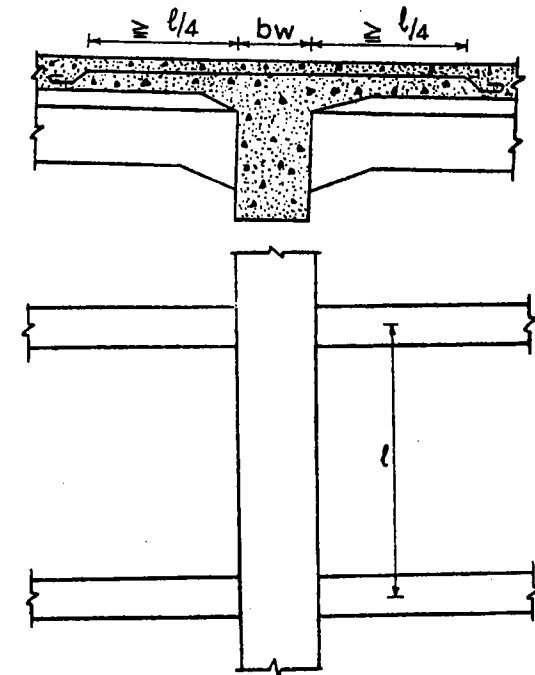

Fig. 11



305.16. Effect of Live Loads on Deck Slabs

305.16.1. The effect of concentrated loads on slabs spanning in one or two directions or on cantilever slabs may be calculated from the influence fields of such loads or by any other rational method. A value of 0.15 may be assumed for Poisson's ratio.

305.16.2. The bending moment per unit width of slab caused by concentrated loads on solid slabs spanning in one direction or on cantilever slabs, may also be calculated by assessing the width of slab that may be taken as effective in resisting the bending moment due to the concentrated loads. For precast slabs, the term 'actual width of slab' used in this Clause shall indicate the actual width of each individual precast unit.

- (l) Solid slab spanning in one direction
- (i) For a single concentrated load, the effective width may be calculated in accordance with the following equation :

$$b_{ef} = \alpha_a \left( 1 - \frac{a}{l_o} \right) + b_1$$

Where  $b_{ef}$  = the effective width of slab on which the load acts,  
 $l_o$  = the effective span as indicated in Clause 305.4,  
 $a$  = the distance of the centre of gravity of the concentrated load from the nearer support,  
 $b_1$  = the breadth of concentration area of the load, i.e., the dimension of the tyre or track contact area over the road surface of the slab in a direction at right angles to the span plus twice the thickness of the wearing coat or surface finish above the structural slab, and  
 $\alpha$  = a constant having the following values depending upon the ratio  $\frac{b}{l_o}$  where  $b$  is the width of the slab

Provided that the effective width shall not exceed the actual width of the slab. And provided further that in case of a load near the unsupported edge of a slab, the effective width shall not exceed the above value nor half the above value plus the distance of the load from the unsupported edge.

$\frac{b}{l_o}$	$\alpha$ for simply supported slab		$\alpha$ for continuous slab	
	$\alpha$ for simply supported slab	$\alpha$ for continuous slab	$\alpha$ for simply supported slab	$\alpha$ for continuous slab
0.1	0.40	0.40	1.1	2.28
0.2	0.80	0.80	1.2	2.36
0.3	1.16	1.16	1.3	2.40
0.4	1.48	1.44	1.4	2.48
0.5	1.72	1.68	1.5	2.48
0.6	1.96	1.84	1.6	2.52
0.7	2.12	1.96	1.7	2.56
0.8	2.24	2.08	1.8	2.60
0.9	2.36	2.16	1.9	2.60
1.0	2.48	2.24	2 & above	2.60

- (ii) For two or more concentrated loads in a line in the direction of the span, the bending moment per unit width of slab shall be calculated separately for each load according to its appropriate effective width of slab calculated as in (i) above.
- (iii) For two or more loads not in a line in the direction of the span : If the effective width of slab for one load overlaps the effective width of slab for an adjacent load, the resultant effective width for the two loads equals the sum of the respective effective widths for each load minus the width of overlap, provided that the slab so designed is tested for the two loads acting separately.

## (2) Solid slab cantilever

- (i) For a single concentrated load, the effective width may be calculated in accordance with the following equation :

$$b_{ef} = 1.2a + b_1$$

Where  $b_{ef}$  = the effective width, $a$  = the distance of the centre of gravity of the concentrated load from the face of the cantilever support, and $b_1$  = the breadth of concentration area of load, i.e., the dimension of the tyre or track contact area over the road surface of the slab in a direction parallel to the supporting edge of the cantilever plus twice the thickness of wearing coat or surface finish above the structural slab.

Provided that the effective width of the cantilever slab shall not exceed one-third the length of the cantilever slab measured parallel to the support. And provided further that when the concentrated load is placed near one of the two extreme ends of the length of cantilever slab in the direction parallel to the support, the effective width shall not exceed the above value, nor shall it exceed half the above value plus the distance of the concentrated load from the nearer extreme end measured in the direction parallel to the fixed edge.

- (ii) For two or more concentrated loads

If the effective width of slab for one load overlaps the effective width of slab for an adjacent load, resultant effective width for the two loads shall be taken as equal to the sum of the respective effective width for each load minus the width of overlap, provided that the slab so designed is tested for the two loads acting separately.

Note : Slabs designed on the above basis need not be checked for shear.

- (3) For ribbed slab or through slab other than solid slabs

The effective width shall depend on the ratio of the transverse and longitudinal flexural rigidities of the slab. When this ratio is one, that is when the transverse and longitudinal flexural rigidities are approximately equal, the value of effective width as found for solid slabs may be used. But as the ratio decreases, a proportionately smaller value shall be taken.

**305.16.3. Dispersion of loads along the span :** The effect of contact of wheel or track load in the direction of span length shall be taken as equal to the dimension of the tyre contact area over the wearing surface of the slab in the direction of the span plus twice the overall depth of the slab inclusive of the thickness of the wearing surface.

**305.16.4. Dispersion of loads through fills and wearing coat :** The dispersion of loads through fills and wearing coat shall be assumed at 45 degrees both along and perpendicular to the span.

**305.17. Stiffening Unsupported Edges of Slabs**

**305.17.1.** Unsupported edges of all slabs shall be suitably stiffened as indicated in the following Clauses :

**305.17.2.** Each unsupported edge of a slab parallel to traffic and beyond the clear road width, shall be so stiffened as to give a resisting moment for any type of flexure equal to or in excess of that of a 300 mm strip of the main roadway slab adjoining the edge. In case of a roadway slab of uniform depth, whether the reinforcement is one-way (parallel to or across the traffic) or two-way, the maximum resisting moment of the roadway slab adjoining the edge and given by a 300 mm strip in any direction shall be taken as the criterion for the resisting moment or the stiffened edge. When the roadway slab is of varying depth in the direction parallel to the edge concerned, the stiffening at any particular point along the length of edge shall

be adjusted according to the resisting moment of the 300 mm adjacent strip at that particular point.

Stiffening of edge may consist of a reinforced kerb section, or an edge stiffening beam.

305.17.3. Unsupported edge along a line across the traffic of a roadway slab (as at the cantilever end of a solid slab cantilever bridge) shall, for a strip of at least 300 mm width in addition to the articulation, if any be suitably stiffened by providing top and bottom reinforcement across the direction of traffic. The sectional area of such reinforcement for a 300 mm width of this strip, both at the top and bottom shall each be not less than the average area of longitudinal reinforcement for 300 mm width at the end of the cantilever.

305.17.4. For cantilever slab, minimum reinforcement of 4 nos. of 16 mm dia HYSD bars shall be provided parallel to the free edge at 150 mm spacing at the tip divided equally between the top and bottom surfaces.

### 305.18. Distribution Reinforcement in Slabs

305.18.1. For solid slabs spanning in one direction, distributing bars shall be provided at right angles to the main tensile bars to provide for the lateral distribution of loads. The distribution reinforcement shall be such as to produce a resisting moment in the direction perpendicular to the span equal to 0.3 times the moment due to concentrated live loads plus 0.2 times the moment due to other loads such as dead load, shrinkage, temperature, etc.

305.18.2. In cantilever slabs and in portions of supported slabs which never experience sagging moment, the total distribution steel shall be distributed half at the top and half at

the bottom of the slab. For cantilever slabs the distribution steel shall be calculated on the basis of 0.3 times the live load moment plus 0.2 times the dead load moment and for portions of supported slabs on the basis of moments indicated in Clause 305.18.1.

### 305.19. Minimum Reinforcement in Beams and Slabs

The area of tension reinforcement in a beam shall be not less than 0.2 per cent of  $bt.d$  when using Fe 415/500 grade bars or 0.3 per cent of  $bt.d$  when using Fe 240 grade where  $bt$  is the breadth of section and  $d$  is the effective depth. For a box, T or I section  $bt$  shall be taken as the average width of concrete below the upper flange.

In slabs the tension reinforcement shall be not less than 0.12 per cent of the total cross-sectional area when using Fe 415/500 grade bars and not less than 0.15 per cent of the total cross-sectional area when using Fe 240 grade bars.

### 305.20. Bending Moments

The bending moments to be provided for at a cross-section of a continuous beam or slab should be the maximum positive and negative moments at such cross-sections, allowing, in both cases, if so desired, for the reduced moments due to the width of the supports, for the following arrangements of superimposed loadings :

- (i) alternate spans loaded and all other spans unloaded.
- (ii) any two adjacent spans loaded and all other spans unloaded.

Except where the approximate values of bending moments are used, the negative moments at the supports for any assumed arrangement of loading may each be increased or decreased by not more than 15 per cent, provided that these modified negative

IRC : 21-2000

moments are used for the calculation of the corresponding moments in the span.

**306. COLUMNS AND COMPRESSION MEMBERS**

**306.1. Classification**

Columns can be classified under the following three categories :

- (i) **Pedestal columns** : Ratio of effective length to least radius of gyration less than 12.
- (ii) **Short columns** : Ratio of effective length to least radius of gyration more than 12 but less than 50.
- (iii) **Long columns** : Ratio of effective length to least radius of gyration more than 50 but less than 150.

306.1.1. For the purpose of calculating the radius of gyration for this clause, the cross-section of the column for columns with binders and in the case of columns with helical reinforcement, the section of the core within the outer surface of the helical reinforcement shall be considered.

306.1.2. For purpose of this Clause the effective column length given in Table 12 should be used, where  $l$  is the length of the column, between adequately restrained supports. The effective column length values given in this Table 13 are in respect of typical cases only and embody the general principles which should be employed in assessing the appropriate value for any particular column.

**306.2. Longitudinal Reinforcement**

306.2.1. In a pedestal column the cross-sectional area of longitudinal reinforcement shall be not less than 0.15 per cent of the gross cross-sectional area of the column and in-column other

**Table 13. Effective Column Length**

Type of column	Effective column length
Properly restrained at both ends in position and direction	$0.75 l$
Properly restrained at both ends in position and imperfectly restrained in direction at one or both ends	A value intermediate between $0.75 l$ and $l$ depending upon the efficiency of the directional restraint
Properly restrained at one end in position and direction and imperfectly restrained in both position and direction at the other end	A value intermediate between $l$ and $2l$ depending upon the efficiency of the imperfect restraint

Notes : Effective length of piers shall be as follows :

- (1) Only pier condition (without superstructure) -  $2 l$
- (2) Superstructure on one side condition -  $1.75 l$
- (3) Service condition with simply supported spans on both sides and pier fixed at base -  $1.2 l$

Where  $l$  is the length of piers between surfaces of restraint. For abutments the conditions (1) and (2) will generally apply.

than pedestal columns, the cross-sectional area of longitudinal reinforcement shall neither be less than 0.8 per cent nor more than 8 per cent of the gross sectional area of the column.

306.2.2. In any column other than pedestal columns that has a larger cross-sectional area than the minimum required to resist the loads including the horizontal forces, the minimum percentage of steel shall be based upon the area of concrete required to resist the direct stress and not upon the actual area. In any case the area of steel provided shall be not less than 0.3 per cent of the gross sectional area of concrete.

306.2.3. A short or long rectangular column shall have a minimum of four longitudinal bars. In case of columns with other than rectangular sections, there shall be one longitudinal bar placed near each angle point of the column.

Short and long columns with helical or circular binders shall have at least six longitudinal bars.

### 306.3. Transverse Reinforcement

306.3.1. A reinforced concrete column shall have transverse reinforcement in the form of lateral ties, circular rings or a helical. They shall be so arranged that every corner bar and alternate longitudinal bar near the face of the column shall have lateral support provided by the corner of a tie having an included angle of not more than 135 degrees and no bar shall be farther than 150 mm from such a laterally supported bar. Where the bars are located around the periphery of a circle, a complete circular tie may be used.

306.3.2. The diameter of transverse reinforcement of any type shall not ordinarily be less than one-quarter the diameter of the largest longitudinal bar in that region of the column and in no case less than 8 mm.

306.3.3. The pitch of transverse reinforcement shall not exceed 300 mm or the lesser of the following two dimensions :

- (i) The least lateral dimension of the column.
- (ii) Twelve times the diameter of the smallest longitudinal reinforcement in the column.

306.3.4. Where the pitch actually adopted is less than the permissible maximum as per Clause 306.3.3, the diameter of the transverse reinforcement may be reduced from that given in Clause 306.3.2 subject to a minimum of 8 mm. But the volume



of lateral reinforcement calculated on the basis of diameter and maximum pitch given by Clauses 306.3.2 and 306.3.3 respectively, shall not be reduced.

306.3.5. In case of helical reinforcement intended for the increased load capacity as per Clause 306.5.2, the helical reinforcement shall in addition to Clauses 306.3.2, 306.3.3 and 306.3.4 satisfy the following requirements :

- (i) Helical reinforcement shall consist of evenly spaced helicals and shall have their ends anchored. The splicing of the helicals shall be made by welding or by a lap of one and a half turns.
- (ii) The pitch of the helicals shall not be more than 75 mm nor more than one sixth the diameter of the core of the column.

### 306.4. Permissible Load on Axially Loaded Columns

306.4.1. On a short column, reinforced with longitudinal bars and lateral ties, the permissible axial load  $N$  on the column shall not exceed the value obtained from the equation :

$$N = \sigma_c o \cdot A_c + \sigma_{sc} A_s$$

Where  $\sigma_c o$  = the permissible stress in direct compression for concrete as given in Clause 303,

$\sigma_{sc}$  = the permissible stress in direct compression for the longitudinal steel as given in Clause 303.2,

$A_c$  = the cross-sectional area of concrete exclusive of any finishing material applied after the casting of the column and exclusive of the areas of longitudinal steel, and

$A_s$  = the cross-sectional area of the longitudinal steel.

306.4.2. On a short column reinforced with longitudinal bars and helicals complying with Clause 306.3.5, the permissible axial load  $N$  on the column shall not exceed that given by the equation in Clause 306.4.1 or by the equation given below

whichever is greater :

$$N = \sigma_c \cdot A_{c0} + \sigma_{sc} \cdot A_s + 2 \sigma_{sp} \cdot A_{sp}$$

Where  $A_{c0}$  = the cross-sectional area of concrete in the column core, excluding the area of longitudinal steel,

$A_{sp}$  = the equivalent area of helical reinforcement (i.e., the volume of helical reinforcement per unit length of the column), and

$\sigma_{sp}$  = Tension in helical reinforcement

The sum of the terms  $\sigma_c \cdot A_{c0}$  and  $2 \sigma_{sp} \cdot A_{sp}$ , shall not exceed  $0.5 f_{ck} A_c$ , where  $f_{ck}$  is the characteristic strength of concrete.

306.4.3. In case of a long column reinforced with longitudinal bars and ties or helical reinforcement, the permissible axial load on the column shall be obtained from the equations given in Clauses 306.4.1 and 306.4.2 respectively provided reduced values of permissible stress for steel and for concrete are taken. Such reduced values of the maximum permissible stresses shall be obtained by multiplying the appropriate maximum permissible stresses given in Clauses 306.4.1 and 306.4.2 by the co-efficient  $\beta$  given by the equation:

$$\beta = 1.5 - \frac{l}{100r}$$

Where  $\beta$  = the reduction co-efficient,

$l$  = the effective length of the column, and

$r$  = the least radius of gyration

Note : When in a column having helical reinforcement, the permissible load is based on the core area, the radius of gyration shall also be based on the diameter of the core.

### 306.5. Design of Sections for Combined Axial Load and Bending

306.5.1. When reinforced concrete section under axial compression is subjected to bending in one or more directions, the section shall be designed by any recognised rational method or by the method given in Clauses 306.5.2 to 306.5.4.

306.5.2. The maximum direct stress and bending stress in the section shall be calculated by the following methods :

- (1) Direct stress :
  - (i) For columns with helical reinforcement complying with Clause 306.3.5.

$$\text{Direct stress} = \frac{N}{A_{c0} + \alpha \cdot A_s + 2 \cdot \alpha \cdot A_{sp}}$$

- (ii) For columns with transverse reinforcement other than that in (i) above.

$$\text{Direct stress} = \frac{N}{A_c + \alpha A_{sp}}$$

- (2) Bending stress =  $\pm \frac{M}{W}$

Where  $N$  = the load on the column in the direction of its axis,  
 $A_c$  = the area of concrete section perpendicular to the axis of the column,  
 $\alpha$  = the modular ratio,  
 $W$  = the section modulus (in case of bending in two directions,  $W$  is the section modulus with reference to the appropriate principal axis for two-way bending), and  
 $M$  = moment

In case of rectangular section subjected to bending in two directions, the expression

$\frac{M}{W}$  in the equation (2) above can be substituted

by

$$\frac{M_x}{W_y} \pm \frac{M_y}{W_x}$$

Where  $M_x$  and  $M_y$  are the bending moments about two principal axis of the section and  $W_y$  and  $W_x$  are the corresponding section moduli.

306.5.3. If the direct and the bending stresses, calculated from equations given in (1) and (2) of Clause 306.5.2 satisfy all the following conditions, the section may be considered safe :

$$(i) \quad \frac{\sigma_{c0, cal}}{\sigma_{c0}} + \frac{\sigma_{c, cal}}{\sigma_c} > 1$$

Where  $\sigma_{c0, cal}$  = the calculated direct compressive stress,

$\sigma_{c0}$  = the permissible direct compressive stress, according to Clause 303; multiplied by the reduction factor given in Clause 306.4.3.

$\sigma_{c, cal}$  = the calculated flexural compressive stress, and

$\sigma_c$  = the permissible flexural compressive stress, according to Clause 303, multiplied by the reduction co-efficient given in Clause 306.4.3.

(ii) The resultant tension due to direct compression and flexure is not greater than the value specified in Table 11 for the appropriate grade of concrete mix.

306.5.4. If the condition given in Clause 306.5.3 (ii) is not satisfied, the section shall be deemed to have cracked in the region of tension and the tensile resistance of concrete is

ignored altogether. The maximum stresses in concrete and steel shall then be found according to the recognised theory of cracked section. The fibre compressive stress in concrete shall not exceed the values given for flexural compressive stress as given in Table 9 and those for tension in steel shall not exceed the permissible stress in reinforcement given in Table 10.

### 307. FOOTING OR BASES

#### 307.1. Allowable Pressure on the Loaded Area

The allowable bearing pressure  $\sigma_{cc}$  with near uniform distribution on the loaded area of a footing or base under a bearing or column shall be given by the following equation :

$$\sigma_{cc} = \sigma_{c0} \sqrt{\frac{A_1}{A_2}}$$

Where  $\sigma_{c0}$  = the permissible direct compressive stress in concrete at the bearing area of the base.

$A_1$  = dispersed concentric area which is geometrically similar to the loaded area  $A_2$ , and also the largest area that can be contained in the plane of  $A_1$ , (maximum width of dispersion beyond the loaded area face shall be limited to twice the height)

$A_2$  = loaded area and,

$$\sqrt{\frac{A_1}{A_2}} \leq 2$$

The projection of the base or footing beyond the face of the bearing or column supported on it shall not be less than 150 mm in any direction.

Adequate reinforcement for spalling and bursting tension shall be provided with small diameter reinforcement at close spacing.

**307.2. Design of Footing**

**307.2.1. Bending moment in footing :** The bending moments at any section of base for a reinforced concrete column or wall shall be taken to be the moment of the forces over the entire area on one side of the section. The critical section for bending in the bases shall be taken at the face of the column or wall.

**307.2.2. Shear**

**307.2.2.1.** The shear strength of the footings - shall be governed by the severer of the following two conditions :

- (a) The footing acting essentially as a wide beam, with a critical section extending in a plane across the entire width; the critical section for this condition shall be assumed as vertical section located from the face of the column, pedestal or wall at a distance equal to the effective depth of the footing.
- (b) Two way action for slab or footing with a critical section perpendicular to plane of slab and so located that its perimeter is minimum but need not approach closer than half the effective depth to the perimeter of concentrated load or reaction area.

**307.2.3. Bond :** The critical section for checking the local bond stress shall be taken to be the same section as given in Clause 307.2.1 and also all other vertical planes where abrupt changes in section occur.

**307.2.4. Tensile reinforcement :** The reinforcement provided to resist the bending moments determined in Clause 307.2.1 shall be distributed uniformly across the full width of the section except that in rectangular footings for columns or pedestals, the reinforcement parallel to the short edge shall be more closely spaced near the column or pedestal in a band width, equal to the short side of the footing. The reinforcement in band width shall be as given below :

*Rv/IRC/102*

$$\frac{\text{Reinforcement in band width}}{\text{Total reinforcement in short direction}} = \frac{2}{(\beta + 1)}$$

Where  $\beta$  is the ratio of the long side to the short side of the footing.

**307.2.5. Design of pile caps**

**307.2.5.1. General :** The pile caps shall be designed either by truss analogy or by bending theory.

**307.2.5.2. Design by truss analogy :** The thickness of pile cap shall be so proportioned to act as stiff member. The minimum thickness of cap shall be 0.5 times the spacing of the pile where there are two rows of piles.

The truss should be a triangular form with a node at the centre of loaded area. The lower node of the truss lie at the intersection of the centre line of the piles with the tension reinforcement. When the truss method issued with widely spaced piles (spacing exceeding three times the pile diameter) only the reinforcement within 1.5 times the pile diameter from the centre of a pile shall be considered to constitute a tension member.

Eighty per cent of the total reinforcement shall be concentrated in strips linking the pile heads and the remainder uniformly distributed throughout the pile cap.

No check for shear is required to be carried out in case pile caps are designed by truss analogy.

**307.2.5.3. Design by bending theory :** The bending moment at any section of the cap for a reinforced concrete column or wall shall be taken to be the moment of the forces over the entire area on one side of the section. The critical



section for bending in the cap shall be taken at the face of the column or wall.

307.2.5.4. **Check for shear** : The critical section for checking shear shall be taken at a distance of effective depth from the face of the column or wall for caps acting in one direction and at a distance of half the effective depth for caps acting in two directions.

Shear on any section for a pile cap shall be in accordance with the following :

- Entire reaction from any pile where its centre is located at a distance half the pile diameter or more outside the section shall be considered as producing shear on that section.
- Reaction from any pile where centre is located at a distance half the pile diameter or more inside the section shall be considered as producing no shear on that section.
- For intermediate positions of pile centre, the portion of the pile reaction to be considered as producing shear on the section shall be based on straight line inter-polation between full value for condition (a) and zero value for condition (b).

307.2.5.5. **Check for punching shear** : The punching shear shall be checked both around the column and the pile on a perimeter, as shown in Fig. 12.

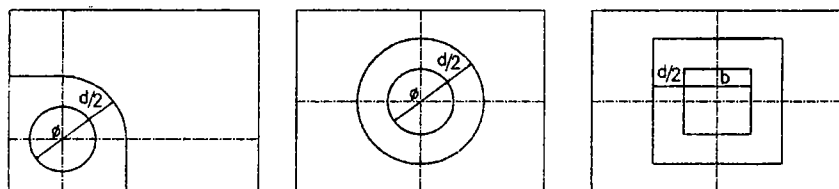

Ø = Diameter of Pier or Pile  
d = Thickness of Cap  
b = Breadth of Pier

Fig. 12. Locations of sections for checking punching shear

The punching shear shall not exceed  $0.16 \sqrt{f_{ck}}$ .

### 308. BALANCED CANTILEVER AND CONTINUOUS CONSTRUCTION

#### 308.1. Moments

308.1.1. At sections where the dead load moment is of a sign opposite to that of the live-load moment, the design bending moment for this condition of loading shall be taken as equal to the live load moment plus 0.7 dead load moment, with proper signs. This condition of loads shall be allowed for in design in addition to the other normal load conditions. However at least 20 per cent of the maximum negative reinforcement at the support shall be carried out right across the span even if not required by design calculations.

#### 308.2. Articulations

308.2.1. The design of bearings at articulations shall ensure that concentrated edge stresses will not be induced and the angular rotation of the cantilevers and the suspended span is possible without any damage to the articulation.

308.2.2. The slope and arrangement of reinforcement of articulation shall be as in the Fig. 13 (a) and (b).

#### 308.3. Distribution of Reinforcement in the Tensile Flange

Where the flanges of T-beams are subjected to tensile stresses in longitudinal direction, the bars of the principal reinforcement shall be suitably distributed along the flanges with some concentration at the position of the web.

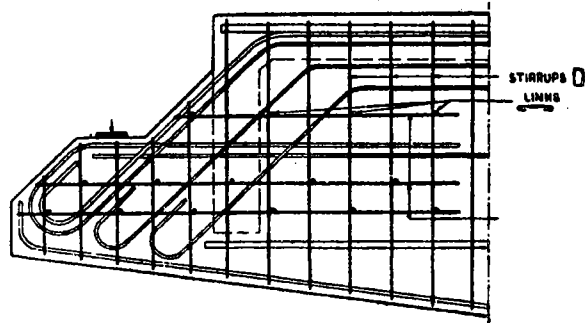

Fig. 13(a). Articulation (general shape and arrangement)

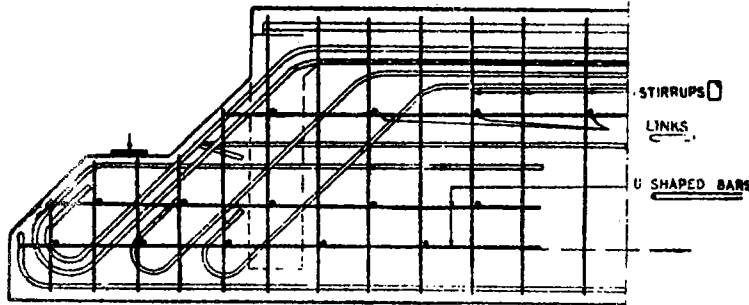

Fig. 13(b). Articulation (general shape and arrangement)

### 309. BOX GIRDERS

#### 309.1. Effective Compression Flange Width

For calculating stresses at any section of a box girder the effective width of the slab functioning as the compression flange shall be in accordance with Clause 305.15.2.

#### 309.2. Soffit Slab Thickness

The minimum thickness of the bottom flange shall be determined by the maximum allowable stresses specified in Clauses 303.1 and 303.2 but in no case shall it be less than 200 mm or one-twentieth of the clear span between the main girders, whichever is **greater**. The thickness of the deck slab and webs shall not be **less than that stipulated** in Clause 305.2.

#### 309.3. Reinforcement of Soffit Slab

Minimum reinforcement of 0.5 per cent of the flange section for Fe 240 grade bar or 0.30 per cent of the flange section for Fe 500/415 grade bars shall be placed in transverse direction distributed equally over both surfaces. Bar spacing shall not exceed 300 mm. These bars shall be bent up into the exterior girder stems at least ten times the bar diameter. In the longitudinal direction, the longitudinal steel needed from stress consideration may be distributed equally between the top and the bottom surfaces and also it must be ensured that each surface has atleast the minimum reinforcement specified in Clause 305.10.

309.4. Reinforcement in the top flange in a direction transverse to the girders shall extend to the exterior face of all outside girders, and a minimum of one-third of such reinforcement shall either be anchored with 90° bends or extended beyond the girder face a sufficient distance to develop the strength of the bar in bond provided the flange projects beyond the girders face a sufficient distance to provide this bond length.

309.5. The minimum clear height inside the box girders shall be 1.5 m to facilitate inspection.

### 310. WORKMANSHIP

#### 310.1. Concrete

Measurement of ingredients: All the ingredients of concrete, i.e., cement, fine and coarse aggregates and water and admixtures, if any, shall be determined by weight. Due allowance shall be made for the weight of moisture present in the aggregates.

#### 310.2. Proportioning Ingredients of Concrete

310.2.1. The proportions of cement, aggregates and

water may be determined by any of the recognised methods of proportioning provided that all the requirements of Clause 303 are satisfied.

310.2.2. Accurate control shall be kept on the quantity of mixing water, which when specified, shall not be changed without the approval of the competent authority.

### 310.3. **Mixing Concrete**

All concrete shall be machine-mixed. In order to ensure uniformity and good quality of concrete, the ingredients shall be mixed in a power driven batch mixer with hopper and suitable weigh batching arrangement or in a central mix plant.

The concrete shall be mixed until it is of even colour and uniform consistency throughout. In no case shall the mixing be done for less than two minutes after all the ingredients are in the mixer.

The addition of water after the completion of the initial mixing operation shall not be permitted.

### 310.4. **Transporting Concrete**

310.4.1. Mixed concrete shall be transported from the place of mixing to the place of final deposit as rapidly as practicable by methods which will prevent the segregation or loss of the ingredients and deposited as near as practicable to its final position to avoid rehandling or flowing.

Concrete may be transported by transit mixers or properly designed buckets or by pumping. Transit mixers or other hauling equipment when used should be equipped with means of discharge of concrete without segregation.

The maximum period between the addition of water to the

mix and the placing and compaction of concrete in final position shall not exceed 30 minutes or the initial setting time of the cement whichever is less, excepting in the case where retarders are used.

310.4.2. When concrete is conveyed by chute, the plant shall be of such size and design as to ensure practically continuous flow in the chute. The slope of the chute shall be such as to allow the concrete to flow without the use of an excessive quantity of water and without segregation of the ingredients. The delivery end of the chute shall be as close as possible to the point of deposit. The chute shall be thoroughly flushed with water before and after each working period and the water used for this purpose discharged outside the formwork.

### 310.5. **Placing and Compacting Concrete**

310.5.1. The concrete shall be placed before setting has commenced and shall not be subsequently disturbed unless retempering is specially permitted. Concrete shall be so placed as to avoid segregation of the materials and displacement of reinforcement. To achieve this concrete should be lowered vertically in the forms and horizontal movement of concrete inside the forms should as far as practicable be brought to a minimum. In wall forms drop chutes attached to hoppers at the top should preferably be used to lower concrete to the bottom of the form. Under no circumstances concrete shall be dropped freely from a height of more than 2 metre.

310.5.2. Concrete shall be thoroughly compacted during the operation of placing and carefully worked around the reinforcement, around embedded fixtures and into the corners of the form work. To achieve proper compaction vibrators shall be used. The vibrator can be internal or external types and depending upon the shape and size of the member both the types

together shall be used. When internal vibrators are used they shall be inserted vertically to the full depth of the layer being placed and ordinarily shall penetrate the layer below for a few centimetres. The vibrator should be kept in place until air bubbles cease escaping from the surface and then withdrawn slowly to ensure that no hole is left in the concrete, care being taken to see that it remains in continued operation while being withdrawn.

The internal vibrators shall be inserted in an orderly manner and the distance between insertions should be about  $1\frac{1}{2}$  times the radius of the area visibly affected by vibration.

### 310.5.3. Construction Joints

310.5.3.1. Concreting shall be carried out continuously upto construction joints, the position and arrangement of which shall be pre-determined by the designer.

310.5.3.2. For a vertical construction joint, a stopping board shall be fixed previously at the pre-determined position and it shall be properly stayed to have sufficient lateral rigidity to prevent displacement or bulging when concrete is compacted against it. Concreting shall be continued right up to the board. The board shall not be removed before the expiry of the period specified in Clause 310.10 for removal of vertical forms. Preparation of the concrete surface and resumption of concreting shall be in accordance with Clause 310.5.4.

310.5.4. Before resuming work at a construction joint when concrete has not yet fully hardened, all laitance shall be removed thoroughly, care being taken to avoid dislodgement of coarse aggregates.

When work has to be resumed on a surface which has

hardened, it should be thoroughly hacked, swept clean, wetted and covered with a layer of neat cement grout. The neat cement grout shall be applied to the surface and this shall be followed by a 10 mm thick layer of cement mixed in the same proportion as that of cement and sand in concrete and the concreting shall be resumed immediately thereafter. The first batch of concrete shall be rammed against the old work to avoid formation of any stone pockets, particular attention being paid to corners and closed spots.

310.5.5. The sequence of concreting, striking of forms and positioning of bearings for every individual structure shall be decided, well in advance of the commencement of work.

310.6. Spacers may be embedded in concrete provided that the quality of the effective cover of any part of the structure is not reduced below the standard required by this code. To ensure adequate cover use of manufactured chairs is recommended.

### 310.7. Curing and Protection of Concrete

The concrete should be kept constantly wet for a minimum period of 14 (fourteen) days except for rapid hardening cement concrete when it can be reduced to 5 (five) days. Water should be applied on unformed surfaces as soon as it can be done without marring the surface and on formed surfaces immediately after the forms are stripped. The concrete shall be kept constantly wet by ponding or covered with a layer of sacking, canvas, hessian or a similar absorbent material and kept constantly wet.

After placing and during the first stages of hardening concrete shall be protected from harmful effects of sunrays, drying winds, cold, running water, shocks, vibrations, traffic including construction traffic etc.

shall be properly braced to make it rigid and strong. Vertical splicing of ballies shall not be permitted.

Where centering trusses or launching trusses are adopted for casting of superstructure, the joints of the centering or launching arrangement, whether welded, revetted or bolted shall be thoroughly checked and various members of the centering trusses shall be examined for proper alignment and unintended deformation before proceeding with the concreting.

The location where fixing of reinforcement and placing of concrete are being done, shall be accessible to the inspecting officers at all stages of construction.

### 310.11. Tests

310.11.1. Tests of cement, aggregates, water etc., to satisfy the requirements of Clause 302 shall be carried out for designing the mix of design mix concrete in accordance with relevant ISI Codes. These tests may also be carried out while arriving at the proportions of ingredients in the case of nominal mix concrete if required by the competent authority.

310.11.2. Tests of reinforcing steel, cement, aggregates and water actually used at site for production of concrete plain or reinforced and if any grade shall be carried out to satisfy the requirements of Clause 302 and in accordance with relevant ISI Codes.

310.11.3. Load tests on the completed structure may be carried out if specially desired.

## DESIGN SURFACE CRACK WIDTH

A.1. The design crack width may be calculated from the following equation :

$$\text{Design surface crack width} = \frac{3 a_{cr} \cdot \epsilon_m}{1 + 2(2c_{min} - c_{min})} (h - x)$$

- Where
- $c_{min}$  = is the minimum cover to the tension steel;
  - $a_{cr}$  = is the perpendicular distance from the point considered to the surface of the nearest longitudinal bar;
  - $\epsilon_m$  = is the average strain at the level where cracking is being considered calculated allowing for the stiffening effect of the concrete in the tension zone; this may be obtained from the equation :

$$\epsilon_m = \epsilon_1 - \frac{[1.2 b_1 h (a' - x)] 10^{-3}}{A_s (h - x) f_y}$$

- Where
- $b_1$  = is the width of the section at the centroid of the tension steel;
  - $a'$  = is the distance from the compression face to the point at which the crack width is being calculated;
  - $h$  = is the overall depth of the member;
  - $\epsilon_1$  = is the average strain at the level where cracking is being considered, calculated ignoring the stiffening effect of the concrete in the tension zone;
  - $x$  = is the depth of the neutral axis found from the analysis to determine  $\epsilon_1$ ;
  - $A_s$  = is the area of tension reinforcement.



IRC : 21-2000

A negative value of  $\epsilon_m$  indicates that the section is uncracked. In assessing the strains the modulus of elasticity of the concrete should be taken as half the instantaneous value.

**A.2. Permissible crack width:** The crack width under sustained loads shall not exceed 0.2 mm for severe conditions of exposure and 0.3 mm for moderate condition of exposure. The conditions of exposure are given in Table 4 and the sustained loads may be taken as dead load plus 50 per cent of live load.

---

