

इंटरनेट

मानक

Disclosure to Promote the Right To Information

Whereas the Parliament of India has set out to provide a practical regime of right to information for citizens to secure access to information under the control of public authorities, in order to promote transparency and accountability in the working of every public authority, and whereas the attached publication of the Bureau of Indian Standards is of particular interest to the public, particularly disadvantaged communities and those engaged in the pursuit of education and knowledge, the attached public safety standard is made available to promote the timely dissemination of this information in an accurate manner to the public.

“जानने का अधिकार, जीने का अधिकार”

Mazdoor Kisan Shakti Sangathan

“The Right to Information, The Right to Live”

“पुराने को छोड़ नये के तरफ”

Jawaharlal Nehru

“Step Out From the Old to the New”

IS 5372 (1975): Taper washers for channels (ISMC) [PGD 31: Bolts, Nuts and Fasteners Accessories]



“ज्ञान से एक नये भारत का निर्माण”

Satyanarayan Gangaram Pitroda

“Invent a New India Using Knowledge”



“ज्ञान एक ऐसा खजाना है जो कभी चुराया नहीं जा सकता है”

Bhartrhari—Nitiśatakam

“Knowledge is such a treasure which cannot be stolen”

BLANK PAGE



Indian Standard
**SPECIFICATION FOR
 TAPER WASHERS FOR CHANNELS (ISMC)**
(First Revision)

1. Scope — Covers the requirements for taper washers for use with Indian Standard Medium Weight Channels (ISMC) with bolts in the diameter range of 10 to 39 mm.

2. Dimensions — As given in Table 1.

TABLE 1 DIMENSIONS OF TAPER WASHERS FOR CHANNELS (ISMC)

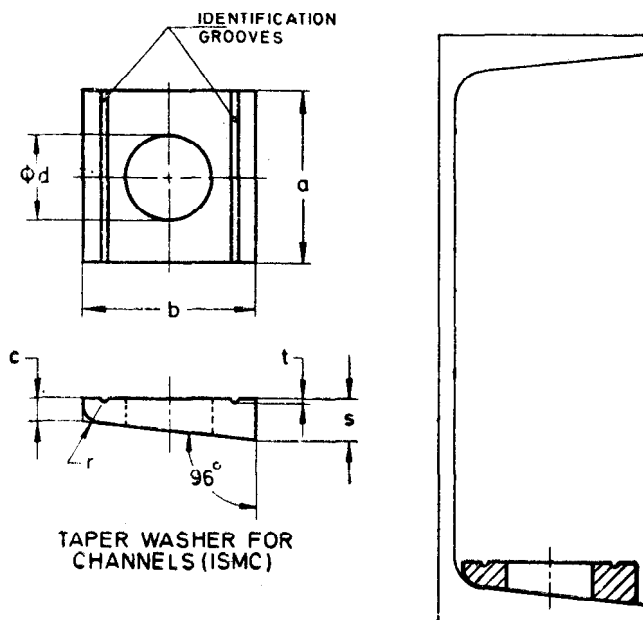

All dimensions in millimetres.

Nominal Size <i>d</i>	<i>a</i>	<i>b</i>	<i>c</i>	<i>r</i>	<i>s</i>	<i>t</i> Approx	For Bolt Size
11	22	22	2	2.4	4.3	0.5	M10
14	26	30	2.5	2.4	5.7	0.7	M12
18	32	36	3	2.4	6.8	0.8	M16
22	40	44	3.5	3.2	8.1	0.9	M20
(24)	44	50	4	3.2	9.2	1	(M22)
26	56	56	4	4.0	9.9	1	M24
(30)	56	56	4	4.0	9.9	1	(M27)
33	62	62	4	4.0	10.5	1.2	M30
(36)	68	68	4	4.0	11.2	1.2	(M33)
39	75	75	4	4.8	11.9	1.2	M36
(42)	80	80	4	4.8	12.4	1.2	(M39)

Note — Sizes shown within parentheses are of second preference.

3. Material — The taper washers shall be made from any suitable low carbon steel.

Note — Suitable low carbon steels are indicated in IS : 1570-1961 'Schedules for wrought steels for general engineering purposes'.

4. Grade — The taper washers shall conform to 'ordinary' grade specified in IS : 5369-1975 'General requirements for plain washers and lock washers (*first revision*)'.

5. Designation — Shall be designated by the name, size and the number of this standard.

Example:

A taper washer of nominal size 18 mm shall be designated as:

Taper Washer 18 IS : 5372

6. Sampling — The sampling and criteria of acceptance shall be in accordance with IS : 6821-1973 'Methods for sampling non-threaded fasteners'.

7. General Requirements — In regard to requirements not covered in this standard, it shall conform to the requirements of ordinary grade washers of IS : 5369-1975 'General requirements for plain washers and lock washers (*first revision*)'.

8. Certification Marking — Details available with the Bureau of Indian Standards.

EXPLANATORY NOTE

This standard was first published in 1969. In the present revision the nominal size 'd' has been modified to the medium series of clearance holes given in IS : 1821-1967 'Dimensions for clearance holes for metric bolts (*first revision*)'. In the preparation of this standard considerable assistance has been derived from DIN 434-1970 Scheiben : vierkant, für U — Trager (Square taper washers for channels), issued by Deutsches Institut für Normung.