

इंटरनेट

मानक



Disclosure to Promote the Right To Information

Whereas the Parliament of India has set out to provide a practical regime of right to information for citizens to secure access to information under the control of public authorities, in order to promote transparency and accountability in the working of every public authority, and whereas the attached publication of the Bureau of Indian Standards is of particular interest to the public, particularly disadvantaged communities and those engaged in the pursuit of education and knowledge, the attached public safety standard is made available to promote the timely dissemination of this information in an accurate manner to the public.

“जानने का अधिकार, जीने का अधिकार”

Mazdoor Kisan Shakti Sangathan

“The Right to Information, The Right to Live”

“पुराने को छोड़ नये के तरफ”

Jawaharlal Nehru

“Step Out From the Old to the New”

IS 1363-3 (2002): Hexagon Head Bolts, Screws and Nuts of Product Grade C, Part 3: Hexagon Nuts (Size Range M5 to M64) [PGD 31: Bolts, Nuts and Fasteners Accessories]

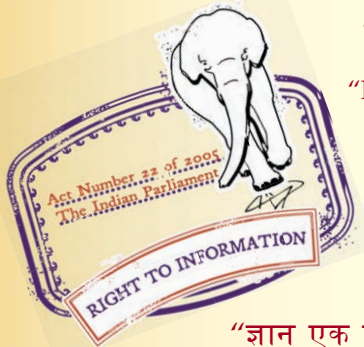

“ज्ञान से एक नये भारत का निर्माण”

Satyanarayan Gangaram Pitroda

“Invent a New India Using Knowledge”



“ज्ञान एक ऐसा खजाना है जो कभी चुराया नहीं जा सकता है”

Bhartrhari—Nitiśatakam

“Knowledge is such a treasure which cannot be stolen”



BLANK PAGE



भारतीय मानक

उत्पाद ग्रेड 'सी' के लिए षटकोणीय शीर्ष वाले
काबले, पेंच और ढिबरियाँ

भाग 3 षटकोणीय ढिबरियाँ (साइज रेंज एम 5 से एम 64 तक)
(चौथा पुनरीक्षण)

Indian Standard

HEXAGON HEAD BOLTS, SCREWS AND
NUTS OF PRODUCT GRADE 'C'

PART 3 HEXAGON NUTS (SIZE RANGE M 5 TO M 64)

(*Fourth Revision*)

ICS 21.060.20

© BIS 2002

BUREAU OF INDIAN STANDARDS
MANAK BHAVAN, 9 BAHADUR SHAH ZAFAR MARG
NEW DELHI 110002

NATIONAL FOREWORD

This Indian Standard (Part 3) (Fourth Revision) which is identical with ISO 4034 : 1999 'Hexagon nuts — Product grade C' issued by the International Organization for Standardization (ISO) was adopted by the Bureau of Indian Standards on the recommendation of the Bolts, Nuts and Fasteners Accessories Sectional Committee and approval of the Basic and Production Engineering Division Council.

IS 1363 was originally published in 1960 and first revised in 1967. Subsequent to the publication of 1967 edition, many changes had been agreed upon at international level which have been reflected in IS 1367 series of standards covering 'Technical supply conditions for threaded steel fasteners'. Accordingly, the second revision was published in 1984 splitting the standard into 3 parts covering hexagon head bolts, hexagon head screws and hexagon nuts. The third revision of this standard was published in 1992 by adoption of ISO 4034 : 1988. This fourth revision has been prepared by adoption of latest edition of ISO 4034 published in 1999. The remaining parts of the standard, that is, Part 1 and Part 2 have also been revised by adopting the corresponding latest editions of ISO Standards published in 1999.

In 1967 version of this standard, the widths across flat dimensions for M10 and M12 size fasteners were specified as 17 mm and 19 mm respectively. However, in the 1984 version these widths across flat dimensions were brought in line with ISO 4034 : 1979 and specified as 16 mm and 18 mm respectively for M10 and M12 size fasteners. Recognizing the difficulty of immediate changeover to new width across flat dimensions, the Committee decided to permit width across flat dimensions as per 1967 version, that is, 17 mm and 19 mm for M10 and M12 size fasteners till 31 December 1994. Now it is expected that the entire fastener industry would have switched over to new width across flat dimensions and from 1 January 1995, no old width across flat dimensions shall be permitted.

The text of ISO Standard has been approved as suitable for publication as Indian Standard without deviations. Certain terminology and conventions are, however, not identical to those used in Indian Standards. Attention is drawn especially to the following:

- a) Wherever the words 'International Standard' appear referring to this standard, they should be read as 'Indian Standard'.
- b) Comma (,) has been used as a decimal marker while in Indian Standards, the current practice is to use a point (.) as the decimal marker.

In this adopted standard, reference appears to certain International Standards for which Indian Standards also exist. The corresponding Indian Standards which are to be substituted in their place are listed below along with their degree of equivalence for the editions indicated:

<i>International Standard</i>	<i>Corresponding Indian Standard</i>	<i>Degree of Equivalence</i>
ISO 225 : 1983	IS 8536 : 1987 Fasteners — Bolts, screws, studs and nuts — Symbols and designation of dimensions (<i>first revision</i>)	Identical
ISO 724 : 1993	IS 4218 (Part 3) : 1999 ISO General purpose metric screw threads: Part 3 Basic dimensions (<i>second revision</i>)	do
ISO 898-2 : 1992	IS 1367 (Part 6) : 1994 Technical supply conditions for threaded steel fasteners: Part 6 Mechanical properties and test methods for nuts, with specified proof loads (<i>third revision</i>)	do

(Continued on third cover)

Indian Standard

**HEXAGON HEAD BOLTS, SCREWS AND
NUTS OF PRODUCT GRADE 'C'**

PART 3 HEXAGON NUTS (SIZE RANGE M 5 TO M 64)

(Fourth Revision)

1 Scope

This International Standard specifies the characteristics of hexagon nuts with threads from M5 up to and including M64 and product grade C.

If, in special cases, specifications other than those listed in this International Standard are required, they should be selected from existing International Standards, for example ISO 724, ISO 898-2, ISO 965-1 and ISO 4759-1.

2 Normative references

The following normative documents contain provisions which, through reference in this text, constitute provisions of this International Standard. For dated references, subsequent amendments to, or revisions of, any of these publications do not apply. However, parties to agreements based on this International Standard are encouraged to investigate the possibility of applying the most recent editions of the normative documents indicated below. For undated references, the latest edition of the normative document referred to applies. Members of ISO and IEC maintain registers of currently valid International Standards.

ISO 225:1983, *Fasteners — Bolts, screws, studs and nuts — Symbols and designations of dimensions.*

ISO 724:1993, *ISO general-purpose metric screw threads — Basic dimensions.*

ISO 898-2:1992, *Mechanical properties of fasteners — Part 2: Nuts with specified proof load values — Coarse thread.*

ISO 965-1:1998, *ISO general purpose metric screw threads — Tolerances — Part 1: Principles and basic data.*

ISO 3269:—¹⁾, *Fasteners — Acceptance inspection.*

ISO 4042:1999, *Fasteners — Electroplated coatings.*

ISO 4759-1:—²⁾, *Tolerances for fasteners — Part 1: Bolts, screws, studs and nuts — Product grades A, B and C.*

ISO 8992:1986, *Fasteners — General requirements for bolts, screws, studs and nuts.*

ISO 10683:—³⁾, *Fasteners — Non-electrolytically applied zinc flake coatings.*

¹⁾ To be published. (Revision of ISO 3269:1988)

²⁾ To be published. (Revision of ISO 4759-1:1978)

³⁾ To be published.

3 Dimensions

See Figure 1 and Tables 1 and 2.

Symbols and descriptions of dimensions are defined in ISO 225.

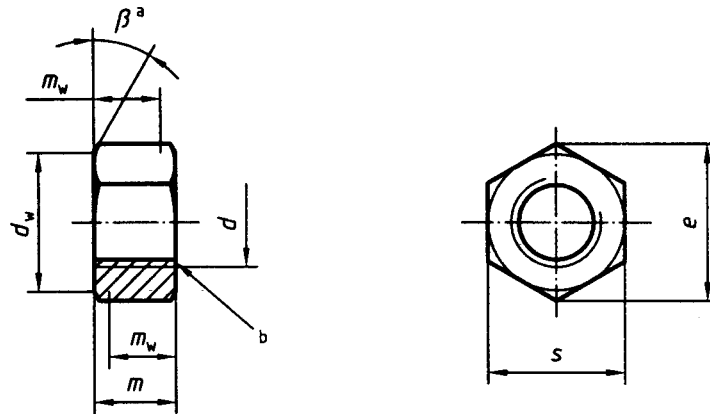

- a $\beta = 15^\circ$ to 30°
- b Countersink at start of thread permissible

Figure 1

Table 1 — Preferred threads

Dimensions in millimetres

Thread (d)		M5	M6	M8	M10	M12	M16	M20
pa		0,8	1	1,25	1,5	1,75	2	2,5
d_w	min.	6,7	8,7	11,5	14,5	16,5	22	27,7
e	min.	8,63	10,89	14,2	17,59	19,85	26,17	32,95
m	max.	5,6	6,4	7,9	9,5	12,2	15,9	19,0
	min.	4,4	4,9	6,4	8,0	10,4	14,1	16,9
m_w	min.	3,5	3,7	5,1	6,4	8,3	11,3	13,5
s	nom. = max.	8,00	10,00	13,00	16,00	18,00	24,00	30,00
	min.	7,64	9,64	12,57	15,57	17,57	23,16	29,16

Thread (d)		M24	M30	M36	M42	M48	M56	M64
pa		3	3,5	4	4,5	5	5,5	6
d_w	min.	33,3	42,8	51,1	60	69,5	78,7	88,2
e	min.	39,55	50,85	60,79	71,3	82,6	93,56	104,86
m	max.	22,3	26,4	31,9	34,9	38,9	45,9	52,4
	min.	20,2	24,3	29,4	32,4	36,4	43,4	49,4
m_w	min.	16,2	19,4	23,2	25,9	29,1	34,7	39,5
s	nom. = max.	36	46	55,0	65,0	75,0	85,0	95,0
	min.	35	45	53,8	63,1	73,1	82,8	92,8

a p is the pitch of the thread.

Table 2 — Non-preferred threads

Dimensions in millimetres

Thread (<i>d</i>)		M14	M18	M22	M27	M33	M39	M45	M52	M60
<i>p_a</i>		2	2,5	2,5	3	3,5	4	4,5	5	5,5
<i>d_w</i>	min.	19,2	24,9	31,4	38	46,6	55,9	64,7	74,2	83,4
<i>e</i>	min.	22,78	29,56	37,29	45,2	55,37	66,44	76,95	88,25	99,21
<i>m</i>	max.	13,9	16,9	20,2	24,7	29,5	34,3	36,9	42,9	48,9
	min.	12,1	15,1	18,1	22,6	27,4	31,8	34,4	40,4	46,4
<i>m_w</i>	min.	9,7	12,1	14,5	18,1	21,9	25,4	27,5	32,3	37,1
<i>s</i>	nom. = max.	21,00	27,00	34	41	50	60,0	70,0	80,0	90,0
	min.	20,16	26,16	33	40	49	58,8	68,1	78,1	87,8

^a *P* is the pitch of the thread.

4 Specifications and reference standards

See Table 3.

Table 3 — Specification and reference standards

Material		Steel
General requirements	International Standard	ISO 8992
Thread	Tolerance	7H
	International Standards	ISO 724, ISO 965-1
Mechanical properties	Property class ^a	<i>d</i> ≤ M16: 5 M16 < <i>d</i> ≤ M39: 4, 5 <i>d</i> > M39: as agreed
	International Standard	<i>d</i> ≤ M39: ISO 898-2 <i>d</i> > M39: as agreed
Tolerances	Product grade	C
	International Standard	ISO 4759-1
Finish and/or coating		As processed Requirements for electroplating are covered in ISO 4042. Requirements for non-electrolytically applied zinc flake coatings are covered in ISO 10683. If different electroplating requirements are desired or if requirements are needed for other finishes, they should be agreed between customer and supplier.
Acceptability		For acceptance procedure, see ISO 3269.

^a For other property classes see ISO 898-2.

5 Designation

EXAMPLE

A hexagon nut with thread M12 and property class 5 is designated as follows:

Hexagon nut ISO 4034 - M12 - 5

Bibliography

- [1] ISO 4014:1999, *Hexagon head bolts — Product grades A and B.*
- [2] ISO 4015:1979, *Hexagon head bolts — Product grade B — Reduced shank (shank diameter approximately equal to pitch diameter).*
- [3] ISO 4016:1999, *Hexagon head bolts — Product grade C.*
- [4] ISO 4017:1999, *Hexagon head screws — Product grades A and B.*
- [5] ISO 4018:1999, *Hexagon head screws — Product grade C.*
- [6] ISO 4032:1999, *Hexagon nuts, style 1 — Product grades A and B.*
- [7] ISO 4033:1999, *Hexagon nuts, style 2 — Product grades A and B.*
- [8] ISO 4035:1999, *Hexagon thin nuts (chamfered) — Product grades A and B.*
- [9] ISO 4036:1999, *Hexagon thin nuts (unchamfered) — Product grade B.*
- [10] ISO 4161:1999, *Hexagon nuts with flange — Coarse thread.*
- [11] ISO 4162:—⁴⁾, *Hexagon bolts with flange — Small series — Product grade combination A/B.*
- [12] ISO 4775:1984, *Hexagon nuts for high-strength structural bolting with large width across flats — Product grade B — Property classes 8 and 10.*
- [13] ISO 7411:1984, *Hexagon bolts for high-strength structural bolting with large width across flats (thread lengths according to ISO 888) — Product grade C — Property classes 8.8 and 10.9.*
- [14] ISO 7412:1984, *Hexagon bolts for high-strength structural bolting with large width across flats (short thread length) — Product grade C — Property classes 8.8 and 10.9.*
- [15] ISO 7413:1984, *Hexagon nuts for structural bolting, style 1, hot-dip galvanized (oversize tapped) — Product grades A and B — Property classes 5, 6 and 8.*
- [16] ISO 7414:1984, *Hexagon nuts for structural bolting with large width across flats, style 1 — Product grade B — Property class 10.*
- [17] ISO 7417:1984, *Hexagon nuts for structural bolting, style 2, hot-dip galvanized (oversize tapped) — Product grade A — Property class 9.*
- [18] ISO 8673:1999, *Hexagon nuts, style 1, with metric fine pitch thread — Product grades A and B.*
- [19] ISO 8674:1999, *Hexagon nuts, style 2, with metric fine pitch thread — Product grades A and B.*
- [20] ISO 8675:1999, *Hexagon thin nuts (chamfered) with metric fine pitch thread — Product grades A and B.*
- [21] ISO 8676:1999, *Hexagon head screws with metric fine pitch thread — Product grades A and B.*
- [22] ISO 8765:1999, *Hexagon head bolts with metric fine pitch thread — Product grades A and B.*
- [23] ISO 10663:1999, *Hexagon nuts with flange — Fine pitch thread.*
- [24] ISO 15071:1999, *Hexagon bolts with flange — Small series — Product grade A.*

⁴⁾ To be published. (Revision of ISO 4162:1990)

(Continued from second cover)

<i>International Standard</i>	<i>Corresponding Indian Standard</i>	<i>Degree of Equivalence</i>
ISO 965-1 : 1998	IS 14962 (Part 1) : 2001 ISO General purpose metric screw threads — Tolerances: Part 1 Principles and basic data	Identical
ISO 3269 : ¹⁾	IS 1367 (Part 17) : 1996 ²⁾ Industrial fasteners — Threaded steel fasteners — Technical supply conditions: Part 17 Inspection, sampling and acceptance procedure (<i>third revision</i>)	do
ISO 4042 : 1999	IS 1367 (Part 11) : 2002 Technical supply conditions for threaded steel fasteners: Part 11 Electroplated coatings (<i>third revision</i>)	do
ISO 4759-1: ³⁾	IS 1367 (Part 2) : 2002 Technical supply conditions for threaded steel fasteners: Part 2 Product grades and tolerances (<i>third revision</i>)	do
ISO 8992 : 1986	IS 1367 (Part 1) : 2002 Technical supply conditions for threaded steel fasteners: Part 1 Introduction and general information (<i>third revision</i>)	do

The concerned Technical Committee has reviewed the provisions of the following ISO Standard referred in this adopted standard and has decided that it is acceptable for use in conjunction with this standard:

<i>ISO Standard</i>	<i>Title</i>
ISO 10683 : ⁴⁾	Fasteners — Non-electrolytically applied zinc flake coatings

ALTERATION

In clause 5, the designation of hexagon nut shall be read as:

'Hexagon nut — IS 1363 (Part 3)/ISO 4034 – M-12-5' in place of **'Hexagon nut — ISO 4034 — M-12-5'**

PACKAGING

The packaging of hexagon nuts shall be in accordance with IS 1367 (Part 18) : 1996 'Industrial fasteners — Threaded steel fasteners — Technical supply conditions: Part 18 Packaging (*third revision*)'.

BIS CERTIFICATION MARKING

Details available with the Bureau of Indian Standards.

For the purpose of deciding whether a particular requirement of this standard is complied with, the final value, observed or calculated, expressing the result of a test or analysis, shall be rounded off in accordance with IS 2 : 1960 'Rules for rounding off numerical values (*revised*)'. The number of significant places retained in the rounded off values should be the same as that of the specified value in this standard.

¹⁾ To be published (Revision of ISO 3269 : 1988).

²⁾ Identical with ISO 3269 : 1988.

³⁾ Since revised in 2000.

⁴⁾ To be published.

Bureau of Indian Standards

BIS is a statutory institution established under the *Bureau of Indian Standards Act, 1986* to promote harmonious development of the activities of standardization, marking and quality certification of goods and attending to connected matters in the country.

Copyright

BIS has the copyright of all its publications. No part of these publications may be reproduced in any form without the prior permission in writing of BIS. This does not preclude the free use, in the course of implementing the standard, of necessary details, such as symbols and sizes, type or grade designations. Enquiries relating to copyright be addressed to the Director (Publications), BIS.

Review of Indian Standards

Amendments are issued to standards as the need arises on the basis of comments. Standards are also reviewed periodically; a standard along with amendments is reaffirmed when such review indicates that no changes are needed; if the review indicates that changes are needed, it is taken up for revision. Users of Indian Standards should ascertain that they are in possession of the latest amendments or edition by referring to the latest issue of 'BIS Catalogue' and 'Standards : Monthly Additions'.

This Indian Standard has been developed from Doc : No. BP 33 (0112).

Amendments Issued Since Publication

Amend No.	Date of Issue	Text Affected

BUREAU OF INDIAN STANDARDS

Headquarters:

Manak Bhavan, 9 Bahadur Shah Zafar Marg, New Delhi 110 002
Telephones : 323 01 31, 323 33 75, 323 94 02

Telegrams: Manaksanstha
(Common to all offices)

Regional Offices :

Central : Manak Bhavan, 9 Bahadur Shah Zafar Marg
NEW DELHI 110 002

Telephone
{ 323 76 17
323 38 41

Eastern : 1/14 C. I. T. Scheme VII M, V. I. P. Road, Kankurgachi
KOLKATA 700 054

{ 337 84 99, 337 85 61
337 86 26, 337 91 20

Northern : SCO 335-336, Sector 34-A, CHANDIGARH 160 022

{ 60 38 43
60 20 25

Southern : C. I. T. Campus, IV Cross Road, CHENNAI 600 113

{ 254 12 16, 254 14 42
254 25 19, 254 13 15

Western : Manakalaya, E9 MIDC, Marol, Andheri (East)
MUMBAI 400 093

{ 832 92 95, 832 78 58
832 78 91, 832 78 92

Branches : AHMADABAD. BANGALORE. BHOPAL. BHUBANESHWAR. COIMBATORE.
FARIDABAD. GHAZIABAD. GUWAHATI. HYDERABAD. JAIPUR. KANPUR.
LUCKNOW. NAGPUR. NALAGARH. PATNA. PUNE. RAJKOT. THIRUVANANTHAPURAM.