

**IS : 1199 - 1959**  
**( Reaffirmed 1991 )**

# *Indian Standard*

## **METHODS OF SAMPLING AND ANALYSIS OF CONCRETE**

**( Eleventh Reprint NOVEMBER 1991 )**

**UDC 666'97:620'11**

**© Copyright 1959**

**BUREAU OF INDIAN STANDARDS**  
**MANAK BHAVAN, 9 BAHADUR SHAH ZAFAR MARG**  
**NEW DELHI 110002**

# *Indian Standard*

## METHODS OF SAMPLING AND ANALYSIS OF CONCRETE

### Cement and Concrete Sectional Committee, BDC 2

#### *Chairman*

SHRI E. A. NADIRSHAH

The Concrete Association of India, Bombay; and  
The Institution of Engineers (India), Calcutta

#### *Members*

SHRI BALESHWAR NATH

Central Board of Irrigation & Power (Ministry of  
Irrigation & Power)

SHRI N. H. BHAGWANANI

Engineer-in-Chief's Branch, Army Headquarters

SHRI N. D. DAFTARY

Bombay State Road Transport Corporation, Bombay

SHRI P. L. DAS

Directorate General of Supplies & Disposals  
(Ministry of Works, Housing & Supply)

DIRECTOR

Central Building Research Institute (CSIR),  
Roorkee

SHRI C. H. KHADILKAR (*Alternate*)

SHRI C. L. HANDA

Directorate of Designs, Bhakra Dam, New Delhi

SHRI P. S. BHATNAGAR (*Alternate*)

DR R. R. HATTIANGADI

The Associated Cement Companies Ltd, Bombay

SHRI V. N. PAI (*Alternate*)

SHRI P. C. HAZRA

Geological Survey of India, Calcutta

DR R. C. HOON

Central Water & Power Commission (Ministry of  
Irrigation & Power)

SHRI GEORGE OOMMEN (*Alternate*)

SHRI S. B. JOSHI

S. B. Joshi & Co, Bombay

SHRI S. R. MEHRA

Central Road Research Institute (CSIR), New Delhi

SHRI S. N. MUKERJI

Government Test House, Calcutta

SHRI K. K. CHATTERJEE (*Alternate*)

SHRI E. P. NICOLAIDES

Gammon India Ltd, Bombay; and Indian Roads  
Congress, New Delhi

REPRESENTATIVE

Martin Burn Ltd, Calcutta

SHRI J. M. RIJHWANI

Central Public Works Department

SHRI M. S. BHATIA (*Alternate*)

SHRI NIHAR CHANDRA ROY

Dalmia Cement (Bharat) Ltd, Calcutta

SHRI A. K. CHAKRAVARTI (*Alternate*)

SHRI SARUP SINGH

National Buildings Organisation (Ministry of Works,  
Housing & Supply)

DEPUTY DIRECTOR (MATERIAL) (*Alternate*)

(Continued on page 2)

BUREAU OF INDIAN STANDARDS  
MANAK BHAVAN, 9 BHADUR SHAH ZAFAR MARG  
NEW DELHI 110002

(Continued from page 1)

*Members*

SHRI H. P. SINHA	Roads Wing, Ministry of Transport & Communications
SHRI J. M. TREHAN ( <i>Alternate</i> )	
SHRI K. C. SOOD	Research, Design & Standardization Organization (Ministry of Railways)
SHRI S. S. VARMA ( <i>Alternate</i> )	
DR LAL C. VERMAN ( <i>Ex-officio</i> )	Director, BIS
<i>Secretary</i>	
SHRI C. S. CHANDRASEKHARA	Deputy Director (Bldg), BIS

Concrete Subcommittee, BDC 2 : 2

*Convener*

SHRI S. B. JOSHI	S. B. Joshi & Co, Bombay
------------------	--------------------------

*Members*

SHRI K. F. ANTIA	The Associated Cement Companies Ltd, Bombay
SHRI N. H. BHAGWANANI	Engineer-in-Chief's Branch, Army Headquarters
SHRI M. S. BHATIA	Central Public Works Department
SHRI T. S. VEDAGIRI ( <i>Alternate</i> )	
DIRECTOR	Engineering Research Laboratories, Hyderabad
SHRI P. C. HAZRA	Geological Survey of India, Calcutta
DR R. C. HOON	Central Water & Power Commission (Ministry of Irrigation & Power)
SHRI G. L. N. IYENGAR	The Concrete Association of India, Bombay
SHRI S. V. NATU	Public Works Department, Bombay
SHRI C. C. PATEL ( <i>Alternate</i> )	
SHRI E. P. NICOLAIDES	Gammon India Ltd, Bombay
DR K. L. RAO	Central Water & Power Commission (Ministry of Irrigation & Power)
SHRI SARUP SINGH	National Buildings Organisation (Ministry of Works, Housing & Supply)
SHRI K. RAMA VARMAN ( <i>Alternate</i> )	
SHRI H. P. SINHA	Roads Wing, Ministry of Transport & Communications
SHRI K. C. SOOD	Research, Design & Standardization Organization (Ministry of Railways)

# *Indian Standard*

## METHODS OF SAMPLING AND ANALYSIS OF CONCRETE

### 0. FOREWORD

**0.1** This Indian Standard was adopted by the Indian Standards Institution on 10 November 1959, after the draft finalized by the Cement and Concrete Sectional Committee had been approved by the Building Division Council.

**0.2** Testing plays an important role in controlling the quality of cement concrete work. Systematic testing of the raw materials for concrete as also, the concrete, both while it is fresh and after it has hardened, is an inseparable part of any quality control programme for concrete. It helps to achieve higher efficiency of the materials used and greater assurance of the performance of the concrete in regard to both strength and durability. The test methods used should be simple, direct and convenient in their application. This standard has been prepared with this object in view and provides a guide to the sampling, analysis, and determination of linear changes of concrete. Strength tests for concrete have been covered separately in IS : 516-1959 Methods of Tests for Strength of Concrete.

**0.3** The Sectional Committee responsible for the preparation of this standard has taken into consideration the views of concrete specialists, testing authorities, consumers and technologists and has related the standard to the practices followed in the country in this field. The need for international co-ordination between standards prevailing in different countries of the world has also been recognized. These considerations led the Sectional Committee to derive assistance from the published standards and publications of the following organizations:

BRITISH STANDARDS INSTITUTION

AMERICAN SOCIETY FOR TESTING AND MATERIALS

AMERICAN CONCRETE INSTITUTE

CANADIAN ENGINEERING STANDARDS ASSOCIATION

RESEARCH, DESIGN & STANDARDIZATION ORGANIZATION, MINISTRY  
OF RAILWAYS, GOVERNMENT OF INDIA

THE CONCRETE ASSOCIATION OF INDIA

**0.4** The Indian Standard Methods of Tests for Strength of Concrete (IS : 516-1959) is a necessary adjunct to this standard. Besides, this

standard requires reference to the following Indian Standards:

\*IS : 269-1958 SPECIFICATION FOR ORDINARY, RAPID-HARDENING AND LOW HEAT PORTLAND CEMENT ( *Revised* )

†IS : 383-1952 SPECIFICATION FOR COARSE AND FINE AGGREGATES FROM NATURAL SOURCES FOR CONCRETE

‡IS : 460-1953 SPECIFICATION FOR TEST SIEVES

**0.4.1** Wherever a reference to any standard mentioned under **0.4**, except IS : 460-1953, appears in this standard, it shall be taken as a reference to the latest version of the standard.

**0.5** In pursuance of the decision of the Government of India to introduce a uniform system of weights and measures throughout the country based on the metric system, in this standard all dimensions and values have been given in metric units only. It is hoped that this step will facilitate the change-over to the metric system by the industry more expeditiously.

**0.6** For the purpose of deciding whether a particular requirement of this standard is complied with, the final value, observed or calculated, expressing the result of a test or analysis, shall be rounded off in accordance with ‡IS : 2-1949 Rules for Rounding Off Numerical Values. The number of significant places retained in the rounded off value should be the same as that of the specified value in this standard.

**0.7** This standard is intended chiefly to cover the technical provisions relating to sampling and analysis of concrete, and it does not include all the necessary provisions of a contract.

---

## 1. SCOPE

**1.1** This standard covers the methods of taking samples of concrete and their analysis.

## 2. TERMINOLOGY

**2.0** For the purpose of this standard, the following definitions shall apply.

**2.1 Absorption ( Air-Dry Basis )** — The percentage of water absorbed by an air-dried aggregate when immersed in water at 27°C for a period of 24 hours.

**2.2 Absorption ( Saturated Surface-Dry Basis )** — The percentage of water absorbed by an aggregate when immersed in water at 27°C

---

\*Third revision in 1976.

†Second revision in 1970.

‡Since revised.

for 24 hours, the aggregate being previously dried in an oven at 105 to 110°C to constant weight.

**2.3 Admixture** — A material other than water, aggregates and portland cement used as an ingredient of concrete and added to it immediately before or during its mixing.

**2.4 Air-Entrained Concrete** — Concrete containing a small volume of air deliberately entrained in the form of minute discrete air voids by the addition of an air-entraining agent.

**2.5 Apparent Specific Gravity** — The weight of the oven-dry aggregate divided by its absolute volume excluding the natural voids in the aggregate particles.

**2.6 Bulk Specific Gravity (Oven-Dry Basis)** — The weight of the aggregate dried to constant weight in an oven at 100°C divided by its absolute volume including the natural voids in the aggregate particles.

**2.7 Bulk Specific Gravity (Saturated Surface-Dry Basis)** — The weight of the saturated surface-dry aggregate divided by its absolute volume including the natural voids in the aggregate particles.

**2.8 Concrete** — A mixture of cement, water and inert aggregates with or without admixtures.

**2.9 Concrete Mix** — A mixture of cement, water and inert aggregates which is freshly mixed during a period of two hours from the time of addition of water to the solid ingredients.

**2.10 Constant Length** — The stage when the difference between two consecutive readings taken of the dimensions of a specimen is less than a specified value. In the case of a 15 cm specimen, this value shall be 0.05 mm and for larger specimens proportionately greater.

**2.11 Drying Shrinkage** — The difference between the length of a specimen cut from a concrete which has been matured and subsequently saturated, and its length when dried to constant length.

**2.12 Drying Shrinkage, Initial** — The difference between the length of a specimen moulded and cured under specified conditions and its length when dried to constant length.

**2.13 Moisture Movement** — The difference between the length of a specimen when dried to constant length and its length when subsequently saturated.

**2.14 Saturated Surface-Dry Weight** — The weight of aggregate whose component pieces are saturated with water but contain no free surface moisture.

**2.15 Surface Moisture** — The moisture contained in the aggregate in excess of that contained in the natural voids of the aggregate.

**2.16 Water Cement Ratio** — The ratio of the weight of water in a concrete mix, exclusive of the water absorbed by aggregates to the weight of cement.

**2.17 Workability** — The property of concrete which determines the amount of useful internal work necessary to produce complete compaction.

### 3. SAMPLING OF FRESH CONCRETE IN THE FIELD

**3.1** This method specifies the procedure to be followed in the field for obtaining representative samples of fresh concrete directly from the mixer or from concrete at the time and place of deposition.

**3.2 Sample** — The composite sample shall be truly representative of the batch and shall be not less than  $0.02 \text{ m}^3$  in volume. It shall be composed of a mixture of portions taken from different points in the batch. When continuous mixers are used, a batch shall be regarded as the discharge from the mixture during one minute.

#### 2.3 Procedure

**3.3.1 From Mixers** — At least three approximately equal sample increments totalling  $0.02 \text{ m}^3$  shall be taken from a batch during its discharge and each sample increment shall be collected by passing a clean and dry receptacle across the stream of concrete. This receptacle shall be constructed of non-absorbent material, preferably of metal and shall be such that the sample retained is not segregated. A flat surface without retaining sides will not fulfil this purpose. Where three sample increments are taken they shall be taken at about the time when one-quarter, one-half and three-quarters of the concrete have been discharged from the mixer and if more than three are taken they shall be at correspondingly shorter, but equally spaced, intervals.

**3.3.2 From Concrete at the Time and Place of Deposition** — The sample shall be taken while a batch of concrete is being, or immediately after it has been, discharged on the site. The sample shall be collected from not less than five well-distributed positions, avoiding the edge of the mass where segregation may have occurred.

**3.4 Mixing the Composite Sample** — The composite sample obtained by either of the methods described above, shall be mixed on a non-absorbent base either with a shovel or by other-suitable implement in such a manner as to ensure uniformity. The sample thus obtained shall be used immediately for the purpose of carrying out the tests. Care shall be taken to protect the sample from the weather.

**3.5 Recording of Samples** — The following information regarding the samples shall be recorded:

- a) date and time of sampling,
- b) method of sampling used,
- c) mix proportions (proportion of ingredients including water, admixtures, etc)
- d) mixture from which delivered (if more than one is used),
- e) the location of the sampled batch after placing, and
- f) temperature and weather conditions.

#### **4. SECURING AND PREPARING TEST SPECIMENS FROM HARDENED CONCRETE**

**4.1 Precautions** — The clause specifies the procedure for securing and preparing test specimens from hardened concrete in structures and pavements. A specimen to be tested for strength shall not be removed from the structure until the concrete has become hard enough to permit its removal without disturbing the bond between the mortar and the coarse aggregate. Normally, the concrete shall be 14 days old before the specimens are removed. Specimens that show abnormal defects or that have been damaged in removal shall not be used.

#### **4.2 Apparatus**

**4.2.1 Drills** — A core drill shall be used for securing cylindrical core specimens. For specimens taken perpendicular to the horizontal surface, a short drill is satisfactory. For inclined holes, a diamond drill is satisfactory.

**4.2.2 Saw** — A saw shall be used for securing beam specimens from the structure or pavement for flexural strength tests. The saw shall have a diamond or silicon carbide cutting edge and shall have adjustments that permit of cutting specimens conforming to the dimensions specified in 4.3.2.

#### **4.3 Test Specimens**

**4.3.1 Core Specimens** — A core specimen for the determination of pavement thickness shall have a diameter of at least 10 cm. A core specimen for the determination of compressive strength shall have a diameter at least three times the maximum nominal size of the coarse aggregate used in the concrete, and in no case shall the diameter of the specimen be less than twice the maximum nominal size of the coarse aggregate. The length of the specimen, when capped, shall be as nearly as practicable twice its diameter.

**4.3.2 Beam Specimen** — The beam specimen for the determination of flexural strength shall normally have a cross-section of 15 × 15 cm and shall be at least 70 cm in length.

**NOTE** — In many cases particularly with prisms cut from pavement slabs, the width is governed by the size of the coarse aggregate and the depth by the thickness of the slabs.



#### 4.4 Procedure

**4.4.1 Core Drilling** — A core specimen taken perpendicular to a horizontal surface shall be located, when possible, with its axis perpendicular to the bed of the concrete as originally placed. A specimen taken perpendicular to a vertical surface, or perpendicular to a surface with a batter, shall be taken from near the middle of a unit of deposit.

**4.4.2 Slab Removal** — A sufficiently large slab shall be removed so that the desired test specimens may be secured without the inclusion of any concrete which has been cracked, spalled, undercut, or otherwise damaged.

**4.4.3 Beam Sawing** — The sawing operation shall be so performed that the concrete will not be weakened by shock or by heating. The sawn surfaces shall be smooth, plane, parallel and shall be free from steps, ridges and grooves. Care shall be taken in handling the sawn beam specimens to avoid chipping or cracking.

#### 4.5 Measurement of Drilled Core Specimens

**4.5.1 Mean Diameter** — The mean diameter shall be determined to the nearest millimetre from three pairs of measurements. The two measurements in each pair shall be taken at right angles to each other, one pair being taken at the middle of the core and the other pairs at the quarter points of the depth. The mean of the six readings shall be taken as the diameter.

**4.5.2 Height** — The height of the core shall be determined by measuring the maximum and minimum heights, which shall be reported to the nearest millimetre.

**4.5.3 Position of Reinforcement** — The positions of any reinforcement shall be determined by measuring to the nearest millimetre from the centre of the exposed bars to the top of the core. The diameter and, if possible, the spacing of the bars shall be recorded, and also the minimum top and bottom cover.

### 5. TESTS FOR WORKABILITY

#### 5.1 Slump Test

**5.1.1** This method of test specifies the procedure to be adopted, either in the laboratory or during the progress of work in the field, for determining, by the slump test, the consistency of concrete where the nominal maximum size of the aggregate does not exceed 38 mm.

#### 5.1.2 Apparatus

- a) *Mould* — The mould for the test specimen shall be in the form of the frustum of a cone having the following internal dimensions:

<i>Dimensions</i>	<i>cm</i>
Bottom diameter	20
Top diameter	10
Height	30

The mould shall be constructed of metal (brass or aluminium shall not be used) of at least 1.6 mm (or 16 BG) thickness and the top and bottom shall be open and at right angles to the axis of the cone. The mould shall have a smooth internal surface. It shall be provided with suitable foot pieces and also handles to facilitate lifting it from the moulded concrete test specimen in a vertical direction as required by the test. A mould provided with a suitable guide attachment may be used. A typical mould without the guide is shown in Fig. 1.

- b) *Tamping rod* — The tamping rod shall be of steel or other suitable material, 16 mm in diameter, 0.6 m long and rounded at one end.

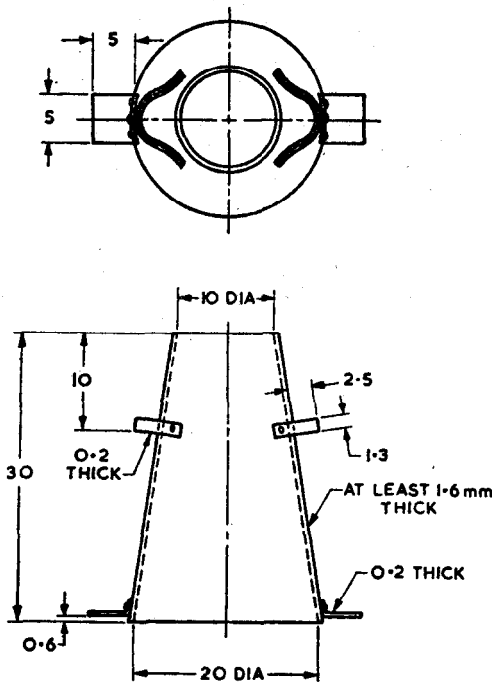

NOTE — To facilitate the lifting of the mould in a vertical direction, it is recommended that suitable guide attachments be provided. Any rivets used in the construction of the mould shall be countersunk flush on the inside of the cone. Attachments should preferably be welded to the mould.

All dimensions in centimetres.

FIG. 1 TYPICAL MOULD FOR SLUMP TEST

**5.1.3 Sampling** — If this test is being carried out in the field, the sample of freshly mixed concrete shall be obtained as described in 3. In the case of concrete containing aggregate of maximum size more than 38 mm, the concrete shall be wet-sieved through  $1\frac{1}{2}$  in screen to exclude aggregate particles bigger than 38 mm.

**5.1.4 Procedure** — The internal surface of the mould shall be thoroughly cleaned and freed from superfluous moisture and any set concrete before commencing the test. The mould shall be placed on a smooth, horizontal, rigid and non-absorbent surface, such as a carefully levelled metal plate, the mould being firmly held in place while it is being filled. The mould shall be filled in four layers, each approximately one-quarter of the height of the mould. Each layer shall be tamped with twenty-five strokes of the rounded end of the tamping rod. The strokes shall be distributed in a uniform manner over the cross-section of the mould and for the second and subsequent layers shall penetrate into the underlying layer. The bottom layer shall be tamped throughout its depth. After the top layer has been rodded, the concrete shall be struck off level with a trowel or the tamping rod, so that the mould is exactly filled. Any mortar which may have leaked out between the mould and the base plate shall be cleaned away. The mould shall be removed from the concrete immediately by raising it slowly and carefully in a vertical direction. This allows the concrete to subside and the slump shall be measured immediately by determining the difference between the height of the mould and that of the highest point of the specimen being tested. The above operations shall be carried out at a place free from vibration or shock, and within a period of two minutes after sampling.

**5.1.5 Slump** — The slump measured shall be recorded in terms of millimetres of subsidence of the specimen during the test. Any slump specimen which collapses or shears off laterally gives incorrect result and if this occurs the test shall be repeated with another sample. If, in the repeat test also, the specimen should shear, the slump shall be measured and the fact that the specimen sheared, shall be recorded.

NOTE — Some indication of the cohesiveness and workability of the mix can be obtained, if after the slump measurement has been completed, the side of the concrete is tapped gently with the tamping rod; a well-proportioned concrete which has an appreciable slump will gradually slump further, but if the mix has been badly proportioned, it is likely to fall apart.

## 5.2 Compacting Factor Test

**5.2.1** This clause specifies a procedure for determining the workability of concrete, where the nominal maximum size of the aggregate does not exceed 38 mm. The test is designed primarily for use in the laboratory, but if circumstances permit, it may also be used in the field. It is more precise and sensitive than the slump test and is particularly useful for

concrete mixes of very low workability as are normally used when concrete is to be compacted by vibration; such concrete may consistently fail to slump.

**5.2.2 Apparatus** — A diagram of the apparatus is shown in Fig. 2. It shall consist of the two conical hoppers (A and B) mounted above a cylindrical mould (C).



VIEW OF TRAP-DOOR  
PARTLY OPEN

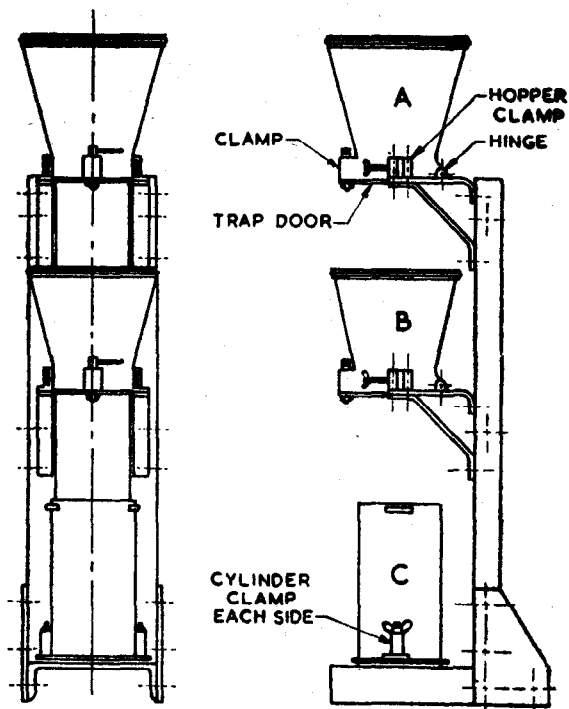

FIG. 2 COMPACTING FACTOR APPARATUS

**5.2.2.1** The essential dimensions of the hoppers and mould and distances between them shall be as shown in Table I. The hopper and cylinder shall be of rigid construction, true to shape and smooth inside. They shall preferably be made of cast brass or bronze, but stout sheet brass or steel may also be considered satisfactory provided the inside surfaces of the joints are smooth and flush. The lower ends of the hoppers shall be closed with tightly fitting hinged trap-doors having quick release catches. Metal plate 3 mm thick is suitable for the doors. The frame in which the hoppers and cylinder are mounted shall be of rigid construction and shall firmly locate them in the relative positions indicated in Table I. The cylinder and hoppers shall be easily detachable from the frame. The apparatus shall also include two ordinary bricklayer's trowels, one hand scoop about 15.2 cm long, a rod of steel or other suitable material of 1.6 cm diameter, 61 cm long rounded at one end, and scales (or a balance) to weigh up to 30 kg, to the nearest 10 g.

**5.2.3 Sampling** — If this test is carried out in the field, the sample of freshly mixed concrete shall be obtained by the method specified under 3. In the case of concrete containing aggregate of maximum size more than 38 mm, the concrete shall be wet-sieved through  $1\frac{1}{2}$  in screen to exclude aggregate particles bigger than 38 mm.

**TABLE I ESSENTIAL DIMENSIONS OF THE COMPACTING FACTOR APPARATUS FOR USE WITH AGGREGATE NOT EXCEEDING 38 mm NOMINAL MAXIMUM SIZE**

( Clause 5.2.2.1 )

DETAIL ( see FIG. 2 )	DIMENSION cm
Upper hopper, A	
Top internal diameter	25.4
Bottom internal diameter	12.7
Internal height	27.9
Lower hopper, B	
Top internal diameter	22.9
Bottom internal diameter	12.7
Internal height	22.9
Cylinder, C	
Internal diameter	15.2
Internal height	30.5
Distance between bottom of upper hopper and top of lower hopper	20.3
Distance between bottom of lower hopper and top of cylinder	20.3

**5.2.4 Procedure** — The sample of concrete to be tested shall be placed gently in the upper hopper, using the hand scoop. The hopper shall be filled level with its brim and the trap-door shall be opened so that the concrete falls into the lower hopper. Certain mixes have a tendency to stick in one or both of the hoppers. If this occurs, the concrete may be helped through by pushing the rod gently into the concrete from the top. During this process, the cylinder shall be covered by the trowels. Immediately after the concrete has come to rest, the cylinder shall be uncovered, the trap-door of the lower hopper opened, and the concrete allowed to fall into the cylinder. The excess of concrete remaining above the level of the top of the cylinder shall then be cut off by holding a trowel in each hand, with the plane of the blades horizontal, and moving them simultaneously one from each side across the top of the cylinder, at the same time keeping them pressed on the top edge of the cylinder. The outside of the cylinder shall then be wiped clean. The above operation shall be carried out at a place free from vibration or shock. The weight of the concrete in the cylinder shall then be determined to the nearest 10 g. This weight shall be known as 'the weight of partially compacted concrete'. The cylinder shall be refilled with concrete from the same sample in layers approximately 5 cm deep, the layers being heavily rammed or preferably vibrated so as to obtain full compaction. The top surface of the fully compacted concrete shall be carefully struck off level with the top of the cylinder. The outside of the cylinder shall then be wiped clean.

**NOTE** — The test is sufficiently sensitive to enable differences in workability arising from the initial processes in the hydration of the cement to be measured. Each test, therefore, should be carried out at a constant time interval after the mixing is completed if strictly comparable results are to be obtained. A convenient time for releasing the concrete from the upper hopper has been found to be 2 minutes after the completion of mixing.

**5.2.5 Calculation** — The compacting factor is defined as the ratio of the weight of partially compacted concrete to the weight of fully compacted concrete. It shall normally be stated to the nearest second decimal place.

### **5.3 Flow of Cement Concrete by the Use of the Flow Table**

**5.3.1** This method of test specifies the procedure for the use of the flow table to determine the fluidity of concrete, where the nominal size of the aggregate does not exceed 38 mm.

#### **5.3.2 Apparatus**

- a) *Mould* — The mould shall be made of a smooth metal casting, as shown in Fig. 3 in the form of the frustum of a cone with the following internal dimensions. A base 25 cm in diameter, upper surface 17 cm in diameter, and height 12 cm; the base and the

top shall be open and at right angles to the axis of the cone. The mould shall be provided with handles.

- b) *Flow table*—Flow table shall conform to the design shown in Fig. 4 and shall be mounted on and bolted to a concrete base having a height of 40 to 50 cm and weighing not less than 140 kg.

5.3.3 *Sampling*—Samples for test shall be obtained by the methods specified under 3. In the case of concrete containing aggregate of maximum size more than 38 mm, the concrete shall be wet-sieved through  $1\frac{1}{2}$  in screen to exclude aggregate particles bigger than 38 mm. They shall be transported to the place of moulding of the specimen, and to counteract segregation, the concrete shall be mixed with a shovel until it is uniform in appearance.

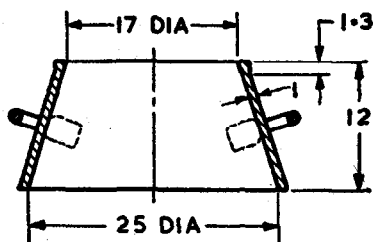
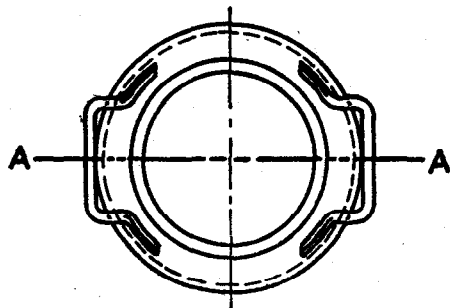

### SECTION AA

All dimensions centimetres.

FIG. 3 MOULD FOR FLOW TEST

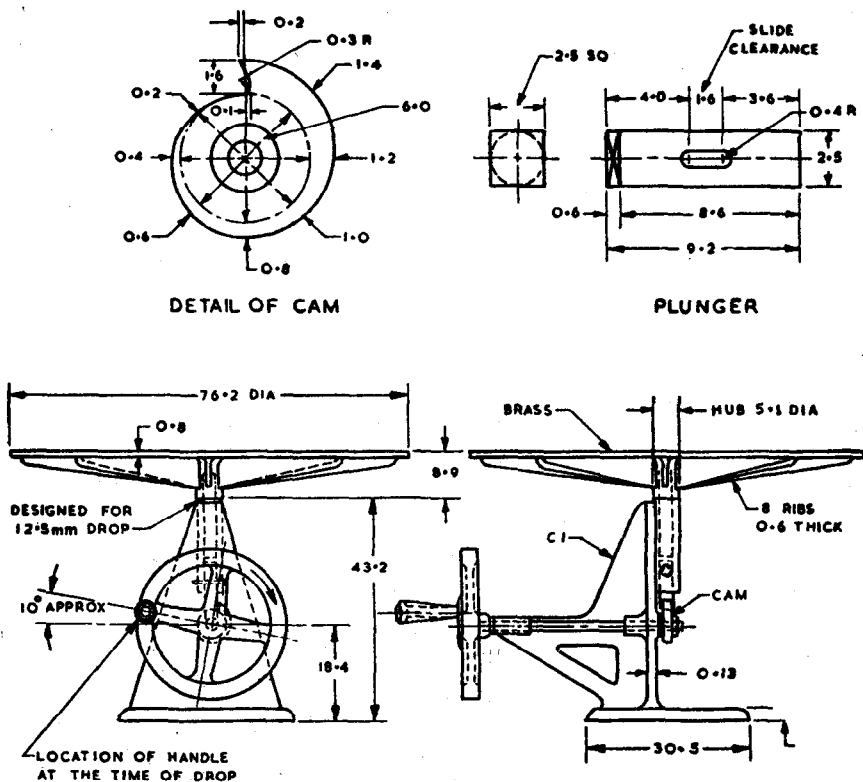

All dimensions in centimetres.

FIG. 4 FLOW TABLE APPARATUS

**5.3.4 Procedure**—Immediately preceding the test, the table top and inside of the mould shall be wetted and cleaned of all gritty material and the excess water removed with a rubber squeezer. The mould, centred on the table, shall be firmly held in place and filled in two layers, each approximately one-half the volume of the mould. Each layer shall be rodded with 25 strokes of a straight round metal rod 1.6 cm in diameter and 61 cm long, rounded at the lower tamping end. The strokes shall be distributed in a uniform manner over the cross-section of the mould and shall penetrate into the underlying layer. The bottom layer shall be rodded throughout its depth. After the top layer has been rodded,



the surface of the concrete shall be struck off with a trowel so that the mould is exactly filled. The excess concrete which has overflowed the mould shall be removed and the area of the table outside the mould again cleaned. The mould shall be immediately removed from the concrete by a steady upward pull. The table shall then be raised and dropped 12.5 mm, 15 times in about 15 seconds. The diameter of the spread concrete shall be the average of six symmetrically distributed caliper measurements read to the nearest 5 mm.

**5.3.5 Recording** — The flow of the concrete shall be recorded as the percentage increase in diameter of the spread concrete over the base diameter of the moulded concrete, calculated from the following formula:

$$\text{Flow, percent} = \frac{\text{spread diameter in cm} - 25}{25} \times 100$$

#### 5.4 Determination of Consistency of Concrete by Vee-Bee Consistometer Method

**5.4.1** This clause deals with the determination of consistency of concrete using a Vee-Bee Consistometer, which determines the time required for transforming, by vibration, a concrete specimen in the shape of a conical frustum into a cylinder.

**5.4.2 Apparatus** — The Vee-Bee Consistometer (see Fig. 5) consists of:

- a) A vibrator table resting upon elastic supports,
- b) A metal pot,
- c) A sheet metal cone, open at both ends, and
- d) A standard iron rod.

**5.4.2.1** The vibrator table (*G*) is 380 mm long and 260 mm wide and is supported on rubber shock absorbers at a height of about 305 mm above floor level. The table is mounted on a base (*K*) which rests on three rubber feet and is equipped with an electrically operated vibrometer mounted under it, operating on either 65 or 220 volts three phase, 50 cycles alternating current. A sheet metal cone (*B*) open at both ends is placed in the metal pot (*A*) and the metal pot is fixed on to the vibrator table by means of two wing-nuts (*H*). The sheet metal cone is 30 cm high and its bottom diameter is 20 cm and top diameter 10 cm. A swivel arm holder (*M*) is fixed to the base and into this is telescoped another swivel arm (*N*) with funnel (*D*) and guide-sleeve (*E*). The swivel arm can be readily detached from the vibrator table. The graduated rod (*J*) is fixed on to the swivel arm and at the end of the graduated arm a glass disc (*C*) is screwed. The division of the scale on the rod records the slump of the concrete cone in centimetres and the volume of concrete after vibration of the cone in the pot. The standard iron rod is 20 mm in diameter and 500 mm in length. The electrical

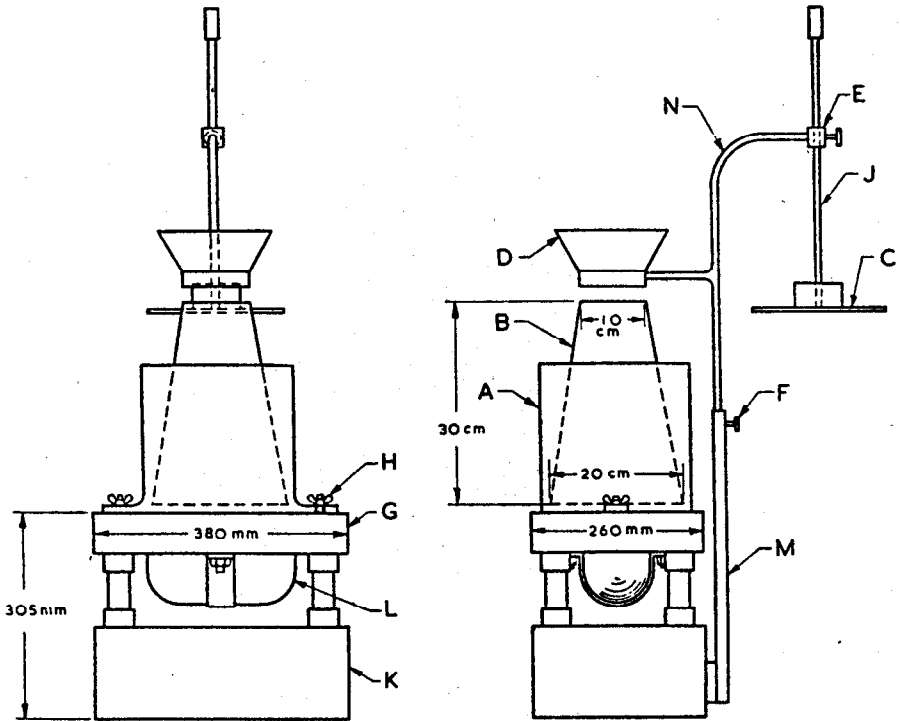

FIG. 5 VEE-BEE CONSISTOMETER, TYPE VBR

rod is 20 mm in diameter and 500 mm in length. The electrical equipment mounted on the base of the consistometer consists of a fixed plug and connector for the electric supply cable, plug and socket contacts for the detachable cable connected to the vibrometer and a control switch. A photograph of the apparatus under operation is given in Fig. 6.

**5.4.3 Procedure** — A slump test as described under 5.1 shall be performed in the sheet metal cylindrical pot of the consistometer. The glass disc (C) attached to the swivel arm shall be moved and placed just on the top of the slump cone in the pot and before the cone is lifted up, the position of the concrete cone shall be noted by adjusting the glass disc attached to the swivel arm. The cone shall then be lifted up and the slump noted on the graduated rod by lowering the glass disc on top of the concrete cone. The electrical vibrator shall then be switched on and the concrete shall be allowed to spread out in the pot. The vibration shall then be continued until the whole concrete surface uniformly adheres

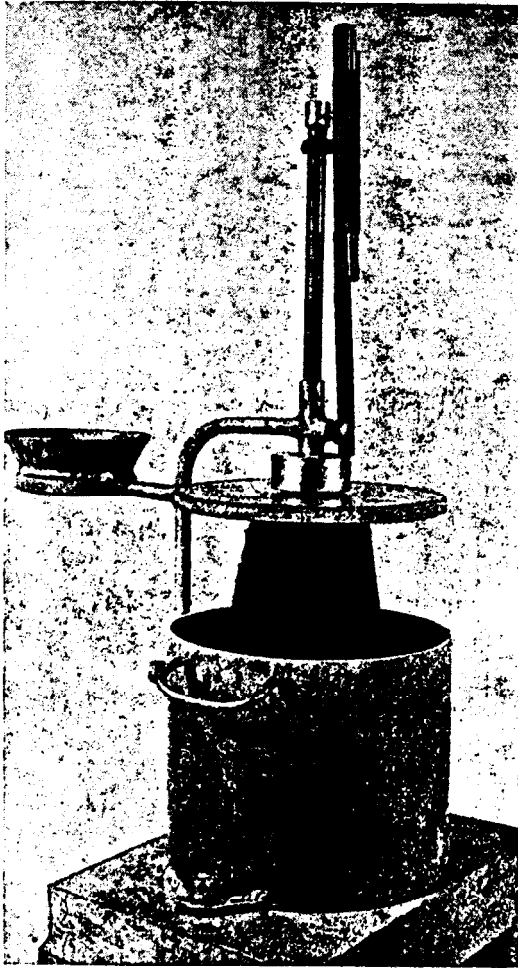

FIG. 6 . VEE-BEE CONSISTOMETER

to the glass disc as indicated in Fig. 6, and the time taken for this to be attained shall be noted with a stop watch. The time is recorded in seconds.

**5.4.4 Result** — The consistency of the concrete shall be expressed in VB-degrees which are equal to the time in seconds recorded in 5.4.3.

5.4.4.1 The required slump is obtained on the basis of the consistency scale given in Table II. The curve in Fig. 7 indicates the relationship between slump in cm and the degrees covered by the consistency scale given in Table II.

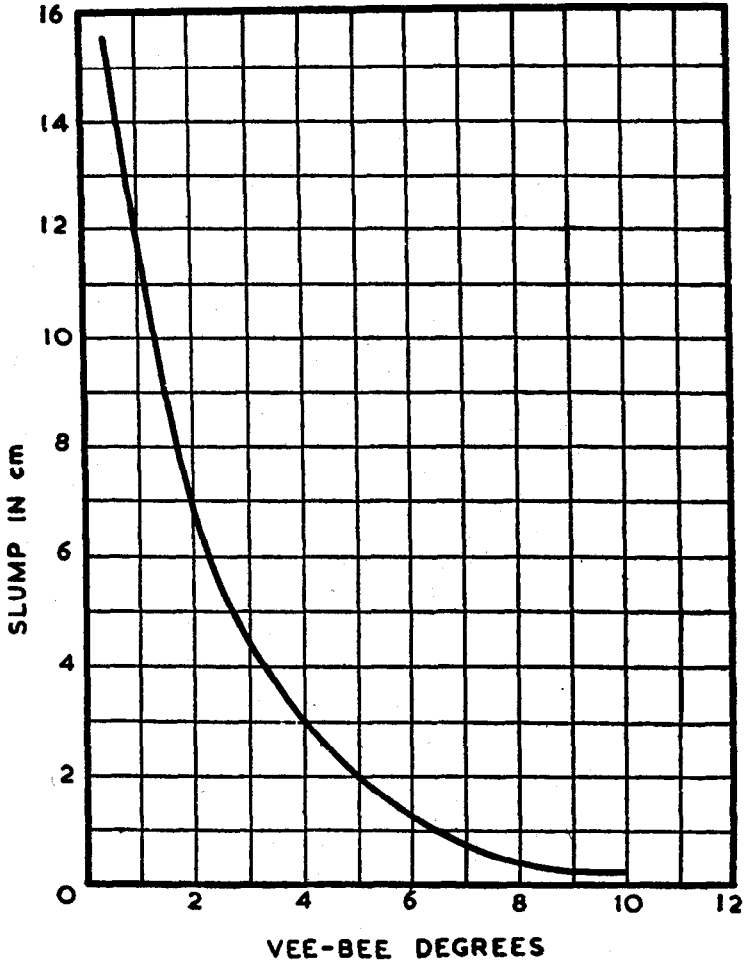

FIG. 7 RELATION BETWEEN SLUMP IN CM AND VEE-BEE DEGREES.

TABLE II CONSISTENCY SCALE

( Clause 5.4.4.1, and Fig. 7 )

CONSISTENCY	NUMBER OF VEE-BEE DEGREES	CHARACTERISTICS
Moist earth	40 to 25-20	Particles of coarse aggregate in the concrete are adhesive, but concrete does not clot. Risk of segregation.
Very dry	20 to 15-10	Concrete has the consistency of very stiff porridge, forms a stiff mound when dumped, and barely tends to shake or roll itself to form an almost horizontal surface when conveyed for a long time in, say, a wheel-barrow.
Dry	10 to 7-5	Concrete has the consistency of stiff porridge, forms a mound when dumped, and shakes or rolls itself to form a horizontal surface when conveyed for a long time in, say, a wheel-barrow.
Plastic	5 to 4-3	Concrete can be shaped into a ball between the palms of the hands, and adheres to the skin.
Semi-fluid	3 to 2-1	Concrete cannot be rolled into a ball between the palms of the hands, but spreads out even though slowly and without affecting the cohesion of the constituents so that segregation does not occur.
Fluid	More fluid than 1	Concrete spreads out rapidly and segregation takes place.

## 6. ANALYSIS OF FRESHLY MIXED CONCRETE

**6.1** This method of analysis deals with the procedure for determining the proportions of the constituents of freshly mixed concrete where the nominal size of the largest aggregate does not exceed 38 mm.

**6.1.1 General Procedure** — A sample of the concrete mix shall be taken and the analysis commenced within five minutes of the time of discharge of the concrete mix from the mixer or agitator. If this is not possible, the sample shall be placed in an air-tight container within five minutes of discharge and stored until the commencement of the analysis which shall be within a period of two hours from the addition of the water to the solid ingredients. Samples of the coarse and fine aggregates from the consignments used for the making of the concrete shall also be taken. Before the analysis of the concrete is carried out, the samples of the aggregates shall be tested for specific gravity, water absorption and proportion passing the appropriate sieves. If, however, the aggregates are obtained

from one source and the variations in the specific gravity do not exceed  $\pm 0.003$ , for the purpose of routine control the tests on the aggregates shall be made at agreed intervals.

**6.2 Apparatus** — The following apparatus, one form of which is shown in Fig. 8, shall be used:

- a) A semi-automatic balance capable of weighing up to 5 kg to an accuracy of 0.5 g. The balance shall be provided with a

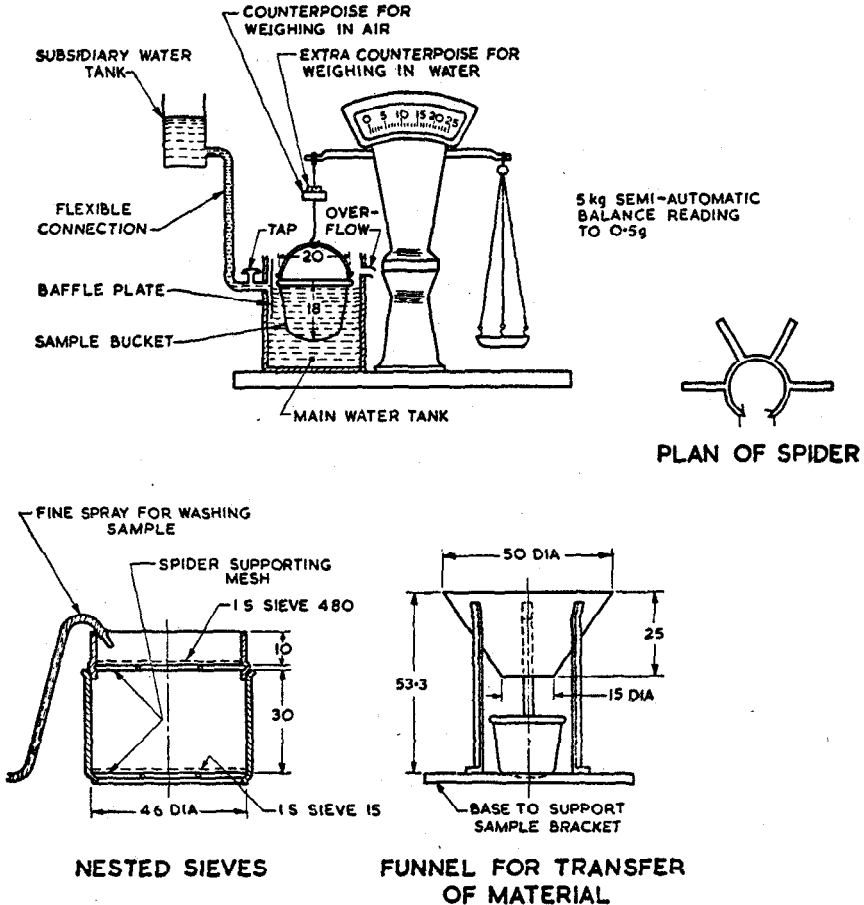

All dimensions in centimetres.

FIG. 8 APPARATUS FOR THE ANALYSIS OF FRESH CONCRETE

counterpoise to obtain equilibrium when an empty bucket is being weighed in air. A second counterpoise shall be provided to secure approximate equilibrium when an empty bucket is being weighed whilst immersed in water. If the sample is to be weighed in air and covered with water at the site before transport to a laboratory for analysis, a balance capable of weighing up to 5 kg to an accuracy of 1 g shall be available at the site.

- b) At least eight bucket-shaped containers made of corrosion resisting metal, each 20 cm in diameter at the top and 18 cm deep, and having sloping sides and a rounded bottom ( to prevent the trapping of air when it is immersed ). The containers shall all be of the same weight in air and each shall be clearly marked with the necessary correction figure to allow for the difference between its loss in weight when immersed in water and the weight of the second counterpoise.
- c) A tank approximately 28 cm in diameter and approximately 30 cm deep. This shall have an overflow spout in such a position that the rim of a bucket hung from the balance is completely immersed when the tank is full. The tank shall be connected by a 6.5 mm dia tap and flexible pipe to a subsidiary tank. This connection shall be such that, when the tap is open and the subsidiary tank is positioned below the main tank, the level of water in the main tank is below the lip of a bucket hanging on the balance. A baffle plate, extending from the top of the tank to a position 5 cm below the connection, shall be provided inside the main tank opposite the connection to the subsidiary tank.
- d) Two nesting sieves 46 cm in diameter, the upper sieve being 10 cm deep and of IS Sieve Designation 480, and the lower sieve being 30 cm deep and of IS Sieve Designation 15.
- e) A funnel approximately 50 cm in diameter at the top, 15 cm diameter at the bottom, and 25 cm deep.
- f) A hose fitted with a nozzle giving a fine spray of water strong enough to move the particles of fine aggregate over the surface of the IS Sieve 15.
- g) A metallic stirring rod, 1.6 cm in diameter.

### 6.3 Method of Taking Samples

**6.3.1 Aggregates** — Four samples of the coarse and four samples of the fine aggregates, as used in the concrete, shall be obtained by taking one main sample for each material and quartering as described in \*IS : 383-1952 until samples of the required size are obtained.

**6.3.2 Concrete Mix** — If the test is being carried out on a concrete mix made in the field, a sample of at least 0.02 m<sup>3</sup> obtained by the method

\*Second revision in 1970.

specified under 3 shall be quartered and remixed until a representative of sample required size is obtained.

**6.3.3 Samples** — Samples shall be taken from each of the various sizes of aggregates in the same nominal proportions as are used in the concrete and such that the total weight of the samples shall be approximately 3.5 kg. The sample of concrete shall weigh approximately 4 kg if the nominal size of coarse aggregate does not exceed 19 mm, otherwise the sample shall weigh approximately 8 kg and it shall be analyzed in two parts, each weighing approximately 4 kg.

#### 6.4 Determination of the Specific Gravity of the Aggregates

**6.4.1** The specific gravity of each of the aggregates shall be determined under conditions identical with those to be applied to the analysis of the concrete. Differences in the temperature of the water at the time of making any weighings during the test shall not exceed 2°C.

**6.4.2** Each sample of the coarse and fine aggregates shall be dried in a ventilated oven at a temperature of 100 to 110°C for 24 hours, cooled and weighed. The weights (in grammes) shall be recorded as  $A_a$  for the coarse aggregate or  $A_s$  for the fine aggregate.

**6.4.3** Each sample shall be placed in a clean bucket [ see 6.2(b) ] and the bucket filled with water to within 25 mm of the lip. The sample shall be stirred for one minute to remove any trapped air and the bucket hung in the water tank from the balance. The water level in the tank shall then be raised steadily by raising the subsidiary tank until the water starts to run from the overflow spout. The sample shall then be weighed in water. During the weighing, the maximum movement of the bucket shall be limited to 6.5 mm to avoid any inaccuracy caused by variations in its displacement or by agitation of the contents. The sample shall be left under water for 20 minutes, stirred, re-immersed and re-weighed, and this procedure shall be repeated until the change in weight between consecutive weighings is less than 0.5 g but in any case the period of immersion shall not exceed 8 hours. The final weights shall be recorded as  $B_a$  for the coarse aggregate or  $B_s$  for the fine aggregate. The time required to attain constant weight shall be recorded.

**6.4.4** The specific gravities shall be calculated as follows:

$$\text{Specific gravity of coarse aggregate} = \frac{A_a}{A_a - B_a}$$

$$\text{Specific gravity of fine aggregate} = \frac{A_s}{A_s - B_s}$$

The average specific gravity of each type of aggregate shall be calculated.



6.4.5 The maximum time required for any of the samples to attain constant weight shall be regarded as the time required for the absorption of water by the aggregates as a whole.

### 6.5 Specific Gravity of the Cement

6.5.1 For the purposes of this test, the specific gravity of portland cement shall be taken as 3.15. If other cements are used, the specific gravity shall be determined by a recognized inert liquid method.

### 6.6 Sieve Analysis

6.6.1 Each of the samples used to determine the specific gravity of the aggregates shall be used to determine the quantity of material passing each of the appropriate sieves.

6.6.2 One sample of the coarse aggregate shall be placed on IS Sieve 480 over the IS Sieve 15 and washed for two minutes under the spray of water, the aggregate being stirred during the washing. The material retained on IS Sieve 480 shall then be washed into a clean bucket by means of the funnel, stirred, immersed in water, and weighed (weight  $D_a$ ).

6.6.3 One sample of fine aggregate shall then be added to any material retained on IS Sieve 15 and washed under the spray of water for at least ten minutes, continuing until the water is clear. The residue retained on the sieve shall be washed into a clean bucket, stirred, immersed and weighed (weight  $D_s$ ). Care shall be taken in making these tests so that no material is lost in transferring the samples to the sieves and back to the buckets.

6.6.4 The correction factors shall be calculated as follows:

$$\text{For the coarse aggregate } C_a = \frac{B_a}{D_a}$$

$$\text{For the fine aggregate } C_s = \frac{B_s}{D_s}$$

NOTE — The correction factors are used to make allowance for the amount of coarse aggregate passing IS Sieve 480 and the amount of total aggregate passing IS Sieve 15.

6.6.5 The above procedure shall be repeated with each of the other three samples of coarse aggregate and of fine aggregate and the average correction factor for each type of aggregate determined.

6.6.6 The maximum time required for washing any of the samples shall be adopted as the time required for washing the concrete on IS Sieve 15 (see 6.7.9).

6.7 Analysis of Concrete — The sample of the concrete shall be placed in a clean bucket and analyzed as follows.

**6.7.1** The sample shall be weighed in air ( weight  $W$  ).

NOTE — This operation may be carried out at the site before the sample is transported to the laboratory. If this is done, the concrete shall be covered with water and the bucket itself covered during transport to the laboratory.

**6.7.2** The bucket shall be filled with water to within 25 mm of the lip and the contents stirred thoroughly for one minute to remove any trapped air.

**6.7.3** The sample shall be left immersed in water for a period of time not less than that required for absorption of water by the aggregate, as determined in accordance with \*IS : 383-1952 but in any case not longer than 8 hours. After this period of immersion, the concrete shall again be thoroughly stirred for one minute to remove any air expelled from the aggregates.

**6.7.4** The bucket shall be hung in the water tank from the balance with the water level in the tank below the lip of the bucket, namely with the subsidiary tank below the main tank and the tap open. The bucket shall then be carefully filled with water up to the lip and the sample left to settle for five minutes.

**6.7.5** The water level in the tank shall then be raised steadily by raising the subsidiary tank. When water overflows from the spout in the main tank, the tap shall be turned off and the sample weighed in water ( weight  $W$  ). During this process, care shall be taken to avoid shaking the sample and the maximum movement of the bucket shall be limited to that specified under 6.4.2. If the water level is raised steadily, little of the water containing fine particles of cement will spill out of the bucket. If the water in the tank becomes discoloured, it shall be changed between weighings to avoid any change in its specific gravity.

**6.7.6** The concrete shall be washed from the bucket on to the IS Sieve 480 placed over IS Sieve 15 [ see 6.2(d) ], care being taken to wash the bucket clean. The sample shall then be washed under the spray of water for at least two minutes continuously until the coarse aggregate is clean, the material being stirred during the washing.

**6.7.7** The clean coarse aggregate retained on the IS Sieve 480 shall then be washed into a clean bucket by means of the funnel and spray of water. The spray shall be used to remove any small particles from the mesh. Unless the water at this stage is clear, the washing specified in 6.7.6 shall be repeated before the aggregate is placed in the bucket.

**6.7.8** The coarse aggregate in the bucket shall be covered with water and stirred thoroughly for one minute. The bucket shall then be immersed in water in the tank and the aggregate weighed as before ( weight  $W_s$  ).

\* Second revision in 1970.

**6.7.9** The fine aggregate remaining on the IS Sieve 15 shall be washed under the spray of water.

**6.7.10** The clean fine aggregate shall be washed into a clean bucket, stirred, immersed in water and weighed as before ( weight  $W_s$  ).

**6.8 Calculation of Proportions** — The proportions of each constituent in the concrete shall be calculated as follows:

The weight of coarse aggregate in the sample,  $W_a = w_a C_a F_a$ .

The weight of fine aggregate in the sample,  $W_s = w_s C_s F_s$ .

The weight of cement in the sample,  $W_c = [ w - ( w_a C_a + w_s C_s ) ] F_c$ .

The weight of water in the sample,  $W_w = W - ( W_a + W_s + W_c )$

where

$$F_a = \frac{\text{specific gravity}}{\text{specific gravity} - 1} \quad \text{for the coarse aggregate,}$$

$$F_s = \frac{\text{specific gravity}}{\text{specific gravity} - 1} \quad \text{for the fine aggregate,}$$

$$F_c = \frac{\text{specific gravity}}{\text{specific gravity} - 1} \quad \text{for the cement,}$$

$W$  = the weight of the concrete in air,

$w$  = the weight of the concrete in water,

$W_a$  = the weight of the coarse aggregate in water,

$W_s$  = the weight of the fine aggregate in water,

$C_a$  = the correction factor for the coarse aggregate, and

$C_s$  = the correction factor for the fine aggregate.

**6.9 Water Cement Ratio** — The water cement ratio by weight may be calculated from the figures in 6.5 as  $W_w/W_c$  and shall be expressed to the nearest 0.01.

**NOTE** — The water/cement ratio as determined by this method includes any water contained in the aggregate before mixing.

**6.10 Report** — The following information shall be reported:

- a) identification mark of sample,
- b) date of test,
- c) weights of constituents,
- d) proportions of constituents,
- e) water cement ratio, and
- f) remarks, such as times for aggregates to attain constant weight.

## 7. DETERMINATION OF WEIGHT PER CUBIC METRE, YIELD, CEMENT FACTOR AND AIR CONTENT OF FRESHLY MIXED CONCRETE

7.1 This method specifies the procedure for determining the weight per cubic metre of freshly mixed concrete, and gives formulae for calculating the volume of concrete per batch, the yield per bag of cement, the cement factor, namely cement content per cubic metre, and the air content of the concrete.

NOTE — This method of calculating air content is of value particularly for air entrained concrete.

### 7.2 Apparatus

7.2.1 *Balance* — The balance shall be sensitive to 0.01 kg.

7.2.2 *Tamping Bar* — The tamping bar shall be a steel bar weighing 1.8 kg, 38 cm long, and shall have a ramming face square.

7.2.3 *Measure* — The measure shall conform to one of the sizes specified in Table III, according to the nominal size of the coarse aggregate in the concrete. The measure shall have a smooth interior, and shall be water-tight and of sufficient rigidity to retain its shape under rough usage. The rim of the measure shall be machined to a plane surface perpendicular to the axis of the cylinder. For convenience, the measure may be provided with handle.

7.2.3.1 *Calibration of measure* — The measure shall be calibrated by determining the weight of water at room temperature required to fill it so that no meniscus is present above the rim. Accurate filling of the measure may be secured by the use of a glass cover plate. The capacity of the measure in cubic metres shall then be obtained by dividing the weight of water (in grams) required to fill the measure by the unit weight of water, 1 000 g/l.

TABLE III DIMENSIONAL REQUIREMENTS FOR CYLINDRICAL MEASURES

( Clause 7.2.3 )

NOMINAL SIZE OF COARSE AGGREGATE mm	NOMINAL CAPACITY cu m	INSIDE DIAMETER mm	INSIDE HEIGHT mm	MINIMUM THICKNESS OF METAL	
				mm	BG
Up to 38	0.01	250	280	4	8
Over 38	0.02	350	285	5.5	5

**7.3 Sampling** — The sample of freshly mixed concrete shall be obtained in accordance with the method specified in 3 except when small batches are made under laboratory conditions.

#### 7.4 Procedure

**7.4.1 Compacting** — The measure shall be filled with concrete as soon as practicable after mixing, in such a way as to produce full compaction of the concrete with neither segregation nor excessive laitance. The concrete shall be filled into the measure in layers approximately 5 cm deep and each layer shall be compacted either by hand or by vibration as described below (see 7.4.1.1 and 7.4.1.2). After the top layer has been compacted, the surface of the concrete shall be struck off level with the top of the measure.

**7.4.1.1 Compacting by hand** — When compacting by hand the standard tamping bar shall be distributed in a uniform manner over the cross-section of the measure.

The number of strokes per layer required to produce the specified condition will vary according to the type of concrete, but in no case shall the concrete be subjected to less than 60 strokes per layer for the 0.01 m<sup>3</sup> measure or 120 strokes per layer for the 0.02 m<sup>3</sup> measure.

**7.4.1.2 Compacting by vibration** — When compacting by vibration each layer shall be vibrated by means of an electric or pneumatic hammer or by means of a suitable vibrating table until the specified condition is attained.

**7.4.2 Tapping** — The exterior surface of the cylinder shall be tapped smartly 10 to 15 times or until no large bubbles of air appear on the surface of the compacted layer.

**7.4.3 Strike-Off, Cleaning and Weighing** — After consolidation of the concrete, the top surface shall be struck-off and finished smoothly with a flat cover plate using great care to leave the measure just level full. All excess concrete shall then be cleaned from the exterior and the filled measure weighed.

#### 7.5 Calculations

**7.5.1 Weight per Cubic Metre** — The weight per cubic metre of concrete shall be calculated by dividing the weight of fully compacted concrete in the measure by the capacity of measure, determined in accordance with 7.2.3.1 and shall be recorded in kg/m<sup>3</sup>.

**7.5.2 Volume of Concrete per Batch** — The volume of concrete produced per batch shall be calculated as follows:

$$V = \frac{(N \times 50) + W_f + W_o + W_w}{W}$$

where

$V$  = volume in cu m of concrete produced per batch,

$N$  = number of 50 kg bags of cement per batch,

$W_f$  = total weight in kg of the fine aggregate per batch in condition used,

$W_c$  = total weight in kg of coarse aggregate per batch in condition used,

$W_w$  = total weight in kg of mixing water added to batch, and

$W$  = weight of concrete in kg/m<sup>3</sup>.

**7.5.3 Yield per Bag of Cement** — The yield shall be calculated as follows:

$$Y = \frac{V}{N}$$

where

$Y$  = yield of concrete per 50 kg bag of cement in m<sup>3</sup>,

$V$  = volume of concrete produced per batch in m<sup>3</sup>, and

$N$  = number of 50 kg bags of cement per batch.

**7.5.4 Cement Factor** — The cement factor shall be calculated as follows:

$$N_1 = \frac{1}{Y}$$

$$\text{or } N_1 = \frac{N}{V}$$

where

$N_1$  = cement factor, that is, number of 50 kg bags of cement per cubic metre of concrete produced,

$Y$  = yield of concrete per 50 kg bags of cement in m<sup>3</sup>,

$N$  = number of 50 kg bags of cement per batch, and

$V$  = volume of concrete produced per batch in m<sup>3</sup>.

**7.5.5 Air Content** — The air content shall be calculated as follows:

$$A = \frac{T - W}{T} \times 100$$

$$\text{or } A = \frac{V - V_A}{V} \times 100$$

where

$A$  = air content (percentage of voids) in the concrete,

$T$  = theoretical weight of the concrete, in kg/m<sup>3</sup>, computed on an air-free basis,

$W$  = weight of concrete in  $\text{kg/m}^3$ ,

$V$  = volume of concrete produced per batch in  $\text{m}^3$ , and

$V_A$  = total absolute volume of the component ingredients in the batch, in  $\text{m}^3$ .

**NOTE**—The determination of the theoretical weight per cubic metre should be carried out in the laboratory; its value is assumed to be constant for all batches made using identical component ingredients and proportions. It is calculated from the formula:

$$T = \frac{W_i}{V_A}$$

where

$T$  = theoretical weight of concrete in  $\text{kg/m}^3$ , computed on an air-free basis,

$W_i$  = total weight in kg of the component ingredients in the batch, and

$V_A$  = total absolute volume of the component ingredients in the batch in  $\text{m}^3$ .

The absolute volume of each ingredient is equal to the weight of that ingredient divided by its specific gravity. For the aggregate components, the bulk specific gravity and weight should be based on the saturated surface-dry condition.

For the cement, a value of 3.15 may be used unless the actual specific gravity is determined by a recognized inert liquid method.

## 8. AIR CONTENT OF FRESHLY MIXED CONCRETE BY THE PRESSURE METHOD

**8.1** This method specifies the procedure for determining the air content of freshly mixed concrete by the pressure method.

**NOTE**—This method is considered adequate for all ordinary types of concrete and mortar, except for concretes or mortars made with highly porous aggregates, where the aggregate correction factor cannot be determined accurately by the technique found satisfactory for the usual types of relatively dense natural aggregates.

### 8.2 Apparatus

- a) *Measuring Bowl*—A flanged cylindrical bowl, preferably of steel or hard metal not readily attacked by the cement paste, having a diameter equal to 1 to 1.25 times the height. The outer rim and upper surface of the flange, as well as the interior surfaces of the bowl, shall be smooth-machined surfaces. The minimum size of the container shall be a function of the size of coarse aggregate in the concrete sample. Containers shall be at least as large as is specified in Table IV, depending on the size of aggregate in the concrete.

The bowl shall be pressure-tight and sufficiently rigid to limit the expansion factor 'D' of the apparatus assembly (see 8.3.5)

**TABLE IV MINIMUM SIZE OF CONTAINERS CORRESPONDING TO NOMINAL MAXIMUM SIZE OF AGGREGATE**

MINIMUM SIZE OF CONTAINER	NOMINAL MAXIMUM SIZE OF AGGREGATE
m <sup>3</sup>	mm
0.005	38
0.01	75
0.1	150

to not more than 0.1 percent of the air content on the standpipe indicator scale when under the normal operating pressure.

NOTE - Large containers may be used for large samples of concrete in order to reduce errors in sampling.

- b) *Conical Cover Assembly* — The flanged cover, preferably of steel or hard metal not readily attacked by the cement paste, shall have interior surfaces inclined not less than 30° from the horizontal. The outer rim and lower surface of the flange and the sloping interior surface shall be pressure-tight and sufficiently rigid to limit the expansion factor of the apparatus assembly as prescribed in 8.2(a). The cover shall be fitted with a standpipe which may be a graduated precision bore glass tube or may be made of metal of uniform bore with a glass water gauge attached. The graduations for a suitable range in air content shall be in percent and tenths of a percent as determined by the proper air pressure calibration test. The internal diameter of the standpipe shall be designed so that under the normal operating pressure the water column will be lowered sufficiently to measure air contents up to 0.1 percent. It is suggested that approximately 25 mm lowering of the water column should represent one percent of air. The applied air pressure shall be indicated by a pressure gauge connected to the air chamber above the water column. The gauge shall have a range of twice the normal working pressure with suitable graduations. (A pressure of 0.5 to 2.0 kg/cm<sup>2</sup> has been used satisfactorily. However, each container shall have to be calibrated for a stated normal procedure.) The cover shall be fitted with a suitable device for venting at the top of the air chamber, an air valve, and a petcock for bleeding off water as required. Suitable means for clamping the cover to the bowl shall be provided to make a pressure-tight seal without entrapping air at the joint between the flanges of the cover and bowl. A suitable hand pump shall be provided with the cover, either as an attachment or as an accessory.



- c) *Calibration Cylinder* — The calibration cylinder shall consist of a cylindrical measure having an internal volume equal to approximately 3 to 6 percent of the volume of the measuring bowl. A satisfactory measure may be machined from 1.6 mm brass tubing (No. 16 BG) (or proper diameter to provide the volume desired) to which a brass disc 6.5 mm in thickness is soldered to form the bottom.
- d) *A Coil Spring* — A coil spring or other means shall be provided for holding the calibration cylinder in place.
- e) *Spray Tube* — A tube of appropriate diameter which may be an integral part of the cover assembly or which may be provided separately so constructed that when water is added to the container, there will be a minimum of disturbance to the concrete.
- f) *A Trowel* — of the ordinary bricklayer's type.
- g) *Tamping Rod* — The tamping rod shall be of steel or other suitable material of 1.6 cm diameter, 61 cm long, and rounded at the tamping end.
- h) *Mallet* — A mallet with a rubber or rawhide head, weighing 250 g for containers smaller than 0.01 cu m capacity and 500 g or more for larger containers.
- j) *Strike-Off Bar* — A strike-off bar consisting of flat straight steel bar.
- k) *Funnel* — A funnel with spout fitting into the tube described in 8.2(e).
- m) *Measure* — A measure having a 2.5 or 5 litre capacity, as required to fill the indicator with water from the top of the concrete to the zero mark.

### 8.3 Calibration

**8.3.1** Change in barometric pressure caused by change in elevation or by changes of temperature and humidity, and rough handling under job conditions, will affect the calibration of pressure type apparatus for determination of air content. The steps described under this clause are prerequisites for the final calibration test to determine the operating pressure  $P$  on the pressure gauge as described hereunder. Normally, this calibration need be made only once (at the time of the initial calibration), or only occasionally to check volume constancy of the calibration cylinder and measuring bowl. On the other hand, the calibration test described in 8.3.7 must be made as frequently as necessary, to ensure that the proper gauge pressure  $P$  is being used in tests for the air content of concrete. Moreover, a change in elevation of more than 183 m (600 ft) from the location at which the apparatus was last calibrated will require calibration in accordance with 8.3.7.

**8.3.2 Calibration of Calibration Cylinder**—The weight of water  $w$  (in grammes) required to fill the calibration cylinder shall be accurately determined, using a scale sensitive to 0.5 g:

**8.3.3 Calibration of Measuring Bowl**—The weight of water  $W$  (in grammes) required to fill the measuring bowl shall be determined, using a scale sensitive to 0.1 percent of the weight of the bowl filled with water. A glass plate is slid carefully over the flange of the bowl in such a manner as to ensure that the bowl is completely filled with water. A thin film of cup grease smeared on the flange of the bowl will make a water-tight joint between the glass plate and the top of the bowl.

**8.3.4 Determination of Constant  $R$** —The constant  $R$  represents the volume of the calibration cylinder expressed as percentage of the volume of the measuring bowl. Calculate  $R$  as follows:

$$R = \frac{100 w}{W} \quad \dots(1)$$

**8.3.5 Determination of Expansion Factor  $D$** —The expansion factor  $D$  for any given apparatus assembly shall be determined by filling the apparatus with water only (making certain that all entrapped air has been removed and the water level is exactly on the zero mark), and applying an air pressure approximately equal to the operating pressure  $P$ , determined by the calibration test described in 8.3.7. The amount by which the water column is lowered shall be the equivalent expansion factor  $D$  for that particular apparatus and pressure.

**NOTE 1**—Although the bowl, cover and clamping mechanism of the apparatus are so constructed that it will be reasonably pressure-tight, the application of internal pressure may result in a small expansion in volume. The expansion will not affect the test results because, with the procedure described in 8.4 and 8.5, the amount of expansion is the same for the test for air in concrete as for the test for aggregate correction factor on combined fine and coarse aggregates, and is thereby automatically cancelled. However, it does enter into the calibration test to determine the air pressure to be used in testing fresh concrete and appears as the value  $D$  in the expression for the calibration factor  $k$ , equation (2) under 8.3.6.

**NOTE 2**—It will be sufficiently accurate for this purpose to use an approximate value for  $P$  determined by making a preliminary calibration test as described in 8.3.7, except that an approximate value for the calibration factor shall be used. For this test  $k = 0.98R$  which is the same as equation (2) under 8.3.6 except that the expansion factor  $D$  as yet unknown, is assumed to be zero.

**8.3.6 Determination of Calibration Factor  $k$** —The calibration factor  $k$  is the amount by which the water column shall be depressed, during the calibration procedure to obtain the gauge pressure required to make the graduations on the glass tube correspond directly to the percentage of air introduced into the measuring bowl by the calibration cylinder when the

bowl is level full of water. Calculate  $k$  as follows:

$$k = 0.98 R D \quad \dots(2)$$

NOTE — The value of  $k$  given in equation (2) is derived from the more general expression:

$$k = HR + D$$

where  $H$  = ratio of the volume of air in the calibration cylinder after the bowl has been filled with water, to the volume before inundation.  $H$  decreases slightly as the elevation above sea level increases and is about 0.980 at sea level for a bowl 20 cm deep, 0.975 at 1 520 m above sea level and 0.970 at 3 960 m above sea level. The error introduced by neglecting these variations in the value of  $H$  will usually be so small (corresponding to less than 0.05 percent air) that equation (2),  $k = 0.98R + D$ , usually will be sufficiently accurate. However, the value of  $H$  should be checked for each design of apparatus, each 10 cm of bowl height decreasing the value of  $H$  by 0.01.

**8.3.7 Calibration Test to Determine Operating Pressure,  $P$ , on Pressure Gauge** — If the rim of the calibration cylinder contains no recesses or projections, it shall be fitted with three or more spacers equally spaced around the circumference. Invert the cylinder and place it at the centre of the dry bottom of the measuring bowl. The spacers shall provide an opening for flow of water into the calibration cylinder when pressure is applied. Secure the inverted cylinder against displacement and carefully lower the conical cover. After the cover is clamped in place, carefully adjust the apparatus assembly to a vertical position and add water at air temperature, by means of the tube and funnel, until it rises above the zero mark on the standpipe. Close the vent and pump air into the apparatus to the approximate operating pressure. Incline the assembly about 30° from the vertical and using the bottom of the bowl as a pivot, describe several complete circles with the upper end of the standpipe, simultaneously tapping the cover and sides of the bowl lightly to remove any entrapped air adhering to the inner surfaces of the apparatus. Return the apparatus to a vertical position, gradually release the pressure (to avoid loss of air from the calibration cylinder) and open the vent. Bring the water level exactly to the zero mark by bleeding water through the petcock in the top of the conical cover. After closing the vent, apply pressure until the water level has dropped an amount equivalent to about 0.1 to 0.2 percent of air more than the value of the calibration factor  $k$ , determined as described in 8.3.6. To relieve local restraints, lightly tap the sides of the bowl, and when the water level is exactly at the value of the calibration factor  $k$ , read the pressure  $P$ , indicated by the gauge and record to the nearest 0.01 kg/cm<sup>2</sup>. Gradually release the pressure and open the vent to determine whether the water level returns to the zero mark when the sides of the bowl are tapped lightly (failure to do so indicates loss of air from the calibration cylinder or loss of water due to a leak in the assembly). If the water level fails to return to within 0.05 percent air of the zero mark and no leakage beyond a few drops of water is found, some air probably was lost from the calibration cylinder. In this case, repeat the calibration procedure step by step from the beginning of this paragraph. If the

leakage is more than a few drops of water, tighten the leaking joint before repeating the calibration pressure. Check the indicated pressure reading promptly by bringing the water level exactly to zero mark, closing the vent, and applying the pressure  $P$ , just determined. Tap the gauge lightly with a finger. When the gauge indicates the exact pressure  $P$ , the water column should read the value of the calibration factor  $k$ , used in the first pressure application within about 0.05 percent of air.

**CAUTION**—The apparatus assembly shall not be moved from the vertical position until pressure has been applied which will force water about one-third of the way up into the calibration cylinder. Any loss of air from this cylinder will nullify the calibration.

**8.3.8 Determination of Aggregate Correction Factor**—The aggregate correction factor shall be determined on a combined sample of fine and coarse aggregates as specified in this clause and illustrated in Fig. 9.

The weights of fine and coarse aggregates present in the volume  $S$ , of the sample of fresh concrete whose air content is to be determined, shall be determined as follows:

$$F_s = \frac{S}{B} \times F_b \quad \dots \quad \dots \quad \dots (4)$$

$$C_s = \frac{S}{B} \times C_b \quad \dots \quad \dots \quad \dots (5)$$

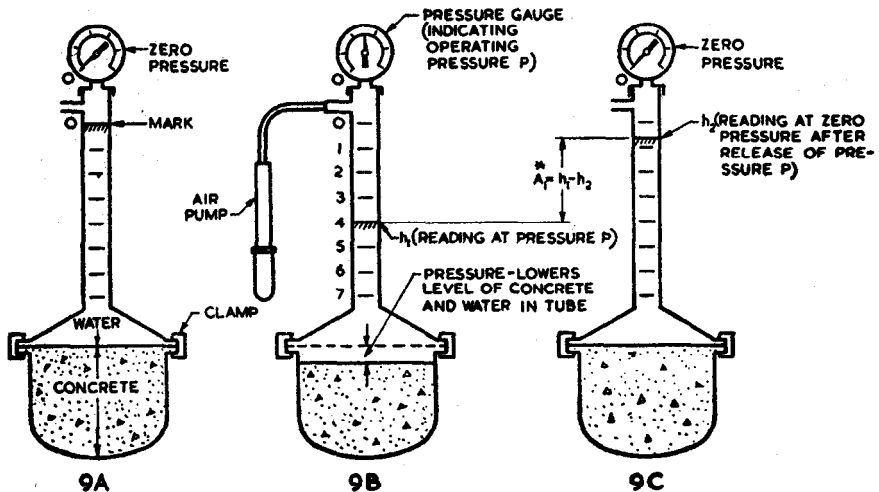

\*  $A_1 = h_1 - h_2$  when bowl contains concrete as shown in this figure; when bowl contains only aggregate and water  $h_1 - h_2 = G$  (aggregate correction factors),  $A_1 - G = A$  (air content, percentage by volume of concrete).

FIG. 9 ILLUSTRATION OF PRESSURE METHOD OF TEST FOR AIR CONTENT

where

$F_s$  = weight in kg of fine aggregate in concrete sample under test,

$S$  = volume in  $m^3$  of concrete sample ( same as volume of measuring bowl of apparatus ),

$B$  = volume in  $m^3$  of concrete produced per batch determined in accordance with 7,

$F_b$  = total weight in kg of fine aggregate in batch,

$C_s$  = weight in kg of coarse aggregate in concrete sample under test, and

$C_b$  = total weight in kg of coarse aggregate in batch.

Mix representative samples of fine aggregate, of weight  $F_s$  and coarse aggregate, of weight  $C_s$ , and place in the measuring bowl filled one-third full of water. Add the mixed aggregate, a small amount at a time, until all the aggregate is inundated. Add each scoopful in a manner that will entrap as little air as possible and remove accumulations of foam promptly. Tap the sides of the bowl and lightly rod the upper layer of the aggregate about ten times and stir after each addition of fine aggregate to eliminate entrapped air.

When all of the aggregate has been placed in the bowl and inundated for at least 5 minutes, strike off all foam and excess water and thoroughly clean the flanges of both bowl and conical cover so that when the cover is clamped in place, pressure-tight seal is obtained. Complete the test as described in 8.4. The aggregate correction factor  $G$  is equal to  $h_1 - h_2$  as determined in the tests on the aggregate.

NOTE — The aggregate correction factor will vary with different aggregates. It can be determined only by test, since apparently it is not directly related to absorption of the particles. The test can be easily made and shall not be ignored. Ordinarily the factor remains reasonably constant for given aggregates, but an occasional check test is recommended.

**8.4 Procedure for Determining Air Content of Concrete**— Place a representative sample of the concrete in the measuring bowl in three equal layers, consolidating each layer by rodding the bowl. Vibration may be substituted for rodding and by tapping the sample when the air content of concrete placed by vibration is to be determined. When the concrete is to be placed by rodding, consolidate each layer of concrete by about 25 strokes of the tamping rod evenly distributed over the cross-section. Follow the rodding of each layer by tapping the sides of the bowl smartly 10 to 15 times with the mallet until the cavities left by rodding are levelled out and no large bubbles of the air appear on the surface of the rodded layer. In rodding the first layer, the rod shall not forcibly strike the bottom of the bowl. In rodding the second and final layers, only enough force shall be used to cause the rod to penetrate the surface of the

previous layer. Slightly overfill the bowl with the third layer and, after rodding or vibration, remove the excess concrete by sliding the strike-off bar across the top flange with a sawing motion until the bowl is just level full.

Thoroughly clean the flanges of the bowl and of the conical cover so that when the cover is clamped in place, a pressure-tight seal will be obtained. Assemble the apparatus and add water over the concrete by means of the tube until it rises to about halfway mark in the standpipe. Incline the apparatus assembly about 30° from vertical end, using the bottom of the bowl as a pivot, describe several complete circles with the upper end of the column simultaneously tapping the conical cover lightly to remove any entrapped air bubbles above the concrete sample. Return the apparatus assembly to its vertical position and fill the water column slightly above the zero mark, while lightly tapping the sides of the bowl. Foam on the surface of the water column may be removed with a syringe or with a spray of alcohol to provide a clear meniscus.

Bring the water level to the zero mark of the graduated tube before closing the vent at the top of the water column ( Fig. 9A ). Apply slightly more than the desired test pressure  $P$  ( 0.02 kg/cm<sup>2</sup> more ) to the concrete by means of the small hand pump. To relieve local restraints, tap the sides of the measures smartly, and when the pressure gauge indicates the exact test pressure  $P$  ( as determined in accordance with 8.3.7 in the calibration test ), read the water level  $h_1$  and record to the nearest division or half division ( 0.10 or 0.05 percent air content ) on the graduated precision bore tube or gauge glass of the standpipe ( Fig. 9B ). For extremely harsh mixes, it may be necessary to tap the bowl vigorously until further tapping produces no change in the indicated air content. Gradually release the air pressure through the vent at the top of the water column and tap the sides of the bowl lightly for about one minute. Record the water level  $h_2$ , to the nearest division or half division ( Fig. 9C ). The apparent air content  $A_1$  is equal to  $h_1 - h_2$ . Repeat the steps specified as above in this clause ( without adding water to re-establish the water level at the zero mark ). The two consecutive determinations of apparent air content should check within 0.2 percent of air and shall be averaged to give the value  $A_1$  to be used in calculating the air content  $A$ , in accordance with 8.5.

**8.5 Calculation** — Calculate the air content of the concrete as follows:

$$A = A_1 - G \quad \dots(6)$$

where

- $A$  = air content, percentage by volume of concrete,
- $A_1$  = apparent air content, percentage by volume of concrete ( see 8.4 ), and
- $G$  = aggregate correction factor, percentage by volume of concrete ( see 8.3.8 ).

## 9. CEMENT CONTENT OF HARDENED PORTLAND CEMENT CONCRETE

**9.1** This method of test specifies the procedure for determining the cement content of hardened portland cement concrete except those containing certain aggregates or admixtures which liberate soluble silica under the conditions of the test, such as slags, diatomites and sodium silicate.

### 9.2 Reagents

**9.2.1 Hydrochloric Acid** — approximately 3.3 N. Add 200 ml of hydrochloric acid (sp gr 1.19) to 600 ml of distilled water.

**9.2.2 Sodium Hydroxide** — approximately 1 N. Dissolve 20 g of hydroxide in 200 ml of water and dilute to a volume of 500 ml.

**9.2.3 Hydrofluoric Acid** — 40 percent.

**9.2.4 Sulphuric Acid** — sp gr 1.84.

**9.3 Preparation of Sample** — Every precaution shall be taken to have the sample of concrete used for analysis truly representative of the material under consideration. Several portions weighing at least 5 kg each shall be taken to avoid all but slight inequalities of the concrete mix. These portions shall then be broken up, crushed in a suitable machine to about one centimetre size and reduced to a fineness of approximately IS Sieve 10 to IS Sieve 8 in a ball mill, disc pulveriser or by any other suitable device. Care shall be taken that the finer fractions of the broken sample, which are richer in cement, are not discarded or lost. After thorough mixing and quartering, a portion approximately 100 g shall be taken and carefully freed, by means of a strong magnet, from particles of metallic iron abraded from the pulveriser ball mill. The clean sample shall then be dried at 105°C for at least 2 hours.

**9.4 Procedure** — Weigh into each of three 250 ml beakers, not less than a 2 g portion of the prepared sample. Moisten with a stream of hot water, while stirring to prevent adhesion to the beaker or the formation of lumps in the mass. Slowly add 100 ml of 3.3 N hydrochloric acid and stir thoroughly. The lumps which tend to form should be reduced with the glass rod. After the evolution of carbon dioxide has ceased and the reaction is apparently complete, heat gently for a few minutes and allow the contents of the beaker to settle. Decant through an ignited and weighed Gooch crucible which contains a mat of short asbestos shreds, practically insoluble in hydrochloric acid and thick enough to be opaque to light. Once the filtration has begun, care shall be taken so that the mat and accumulated residue do not dry out completely until the filtration process is complete. Regulate the suction so as to maintain a rapid rate of dropping during the greater part of the filtration. Retain as much of the residue in the beaker as possible. Wash by decantation twice with

hot water. Add 75 ml of 1 N sodium hydroxide to the residue while stirring and heat to about 75°C. Decant as before and wash twice with hot water. Transfer the residue to the crucible and wash with at least 60 ml of hot water.

**9.5** The filtrate now contains the silica in the form of silicic acid in true solution or in suspension in the hydrochloric acid medium. If the aggregates of the original sample are largely calcareous or dolomitic, add 10 ml of hydrochloric acid (sp.gr 1.19) to the solution. Transfer to a suitable beaker with several rinsings of the filter-flask. Evaporate to dryness with great care to minimize spattering, bake at not over 120°C for one hour, moisten with hydrochloric acid (sp.gr 1.19), evaporate and bake again and take for filtration in 75 ml of 2 N or 3 N hydrochloric acid heated to boiling. Filter through an ashless filter paper and wash the residue with 50 ml of hot 1 N hydrochloric acid and then with hot water until the washings are free from chloride. Repeat the evaporation and filtering processes to recover the small amounts of silica dissolved and add these to the first residue. Determine the silica present in the sample by treatment with hydrofluoric and sulphuric acids in accordance with the procedure given in Appendix A of IS : 269-1958\*.

**9.6 Correction Factor** — When the aggregates, used in the concrete being analyzed, are available, a blank test shall be run on these aggregates to determine their content of silica, soluble under the conditions of the test (see 9.4). This content of the soluble silica shall then be used as a correction factor and be subtracted from the total soluble silica found in the concrete, the difference being due to the cement contained in the specimen.

**9.7 Calculation** — The percentage of cement in the sample shall be calculated by dividing the percentage of silica found by the factor 0.214 0, provided the silica content of the cement is not known to be different from this value. When possible, the known value shall be taken as the factor.

## **10. DETERMINATION OF CHANGES IN LENGTH ON DRYING AND WETTING ( INITIAL DRYING SHRINKAGE, DRYING SHRINKAGE, MOISTURE MOVEMENT )**

**10.1** This method of test specifies the procedure for determining the change in length of concrete specimens due to changes in moisture content. It deals with tests both on laboratory specimens and specimens cut from structures or units, when the maximum nominal size of the aggregate in either does not exceed 38 mm.

### **10.2 Apparatus**

**10.2.1 Measuring Apparatus** — A measuring apparatus shall be used which incorporates a micrometer gauge or a suitable dial gauge reading

\*Second revision in 1967.



accurately to 0.005 mm. This gauge shall be rigidly mounted in a measuring frame and shall have a recessed end which can be located upon a 6.5 mm diameter ball or other reference point cemented in the specimen as described under 10.3. The other end of the frame shall have a similar recessed seating which can be located upon a second ball or reference point in the specimen. An invar steel rod of a suitable length with 6.5 mm diameter hemispherical ends, or with 6.5 mm diameter steel balls mounted at the ends shall be used as a standard of length against which the readings of the gauge can be tested, thus enabling corrections to be made for any changes in the dimensions of the apparatus between successive measurements of a test specimen. The apparatus shall preferably be adjustable for specimens of different lengths and invar rods shall be available in lengths approximating to those of the specimens to be tested. Typical forms of apparatus are shown in Fig. 10 and 11, but other suitable forms may be used. The apparatus shown in Fig. 10 is to be prepared for large specimens and those of higher densities, since the pressure caused by the weight of the specimen, which would otherwise fall on the lower reference ball, is carried by the slotted shelf.

**10.2.2 Drying Oven** — The drying oven shall comply with the following requirements:

- a) It shall have an internal volume equivalent to not less than 0.008 m<sup>3</sup> per specimen, with a minimum total volume of 0.05 m<sup>3</sup>.
- b) It shall be reasonably air-tight and shall be provided with a fan to keep the air circulating effectively during the drying of the specimens.
- c) It shall be maintained at a temperature of 50 ± 1°C.
- d) The humidity of the air in the oven shall be controlled at approximately 17 percent relative humidity by means of saturated calcium chloride solution. Suitable dishes or trays containing this solution shall be provided to give an exposed area of solution not less than one square metre for each cubic metre volume of the oven. The dishes or trays shall contain sufficient solid calcium chloride to show above the surface of the solution throughout the test.

**10.3 Sample Size** — Specimens shall be cast or cut with a length of 15 to 30 cm and a cross-section as near as practicable to 7.5 × 7.5 cm.

**10.3.1 Cast Specimens** — Where the test is carried out upon a specimen made specially for testing, it shall, unless other curing conditions are specified, be stored for the first three to seven days in moist air. During this period, two reference points consisting of 6.5 mm diameter steel balls or other suitable reference points providing a 6.5 mm diameter hemispherical bearing shall be cemented with neat rapid hardening portland cement or other suitable cementing agent into the centre of each end of the specimen

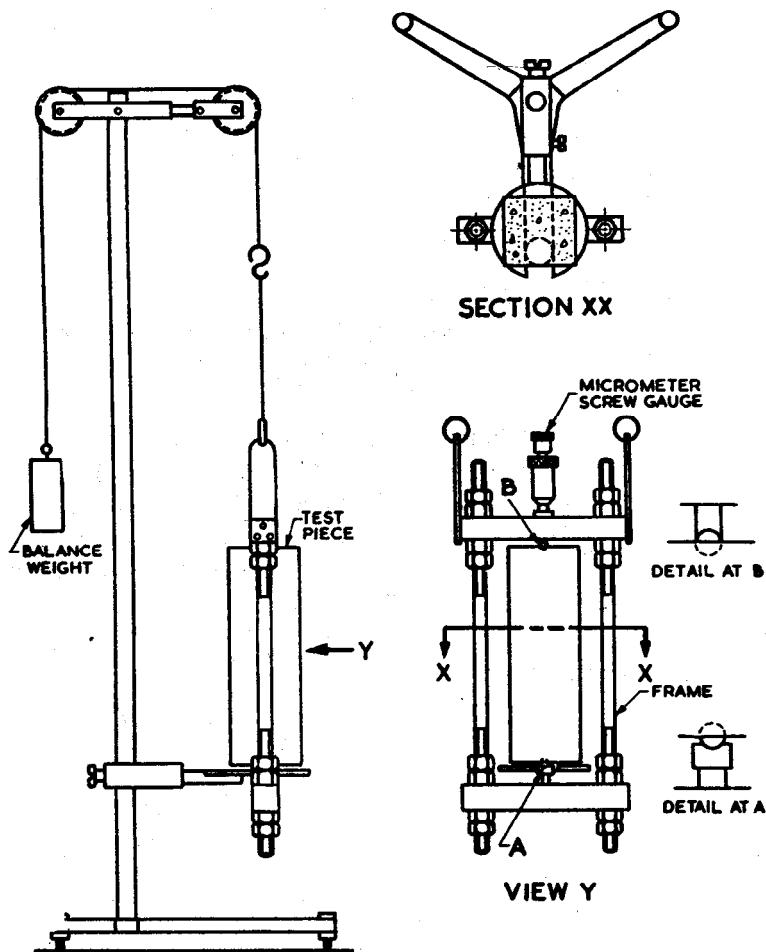

NOTE — When apparatus is fitted with locknuts, as shown above, care should be taken that the first nut is tight before locking the second nut.

FIG. 10 TYPICAL APPARATUS FOR DRYING SHRINKAGE AND MOISTURE MOVEMENT TESTS

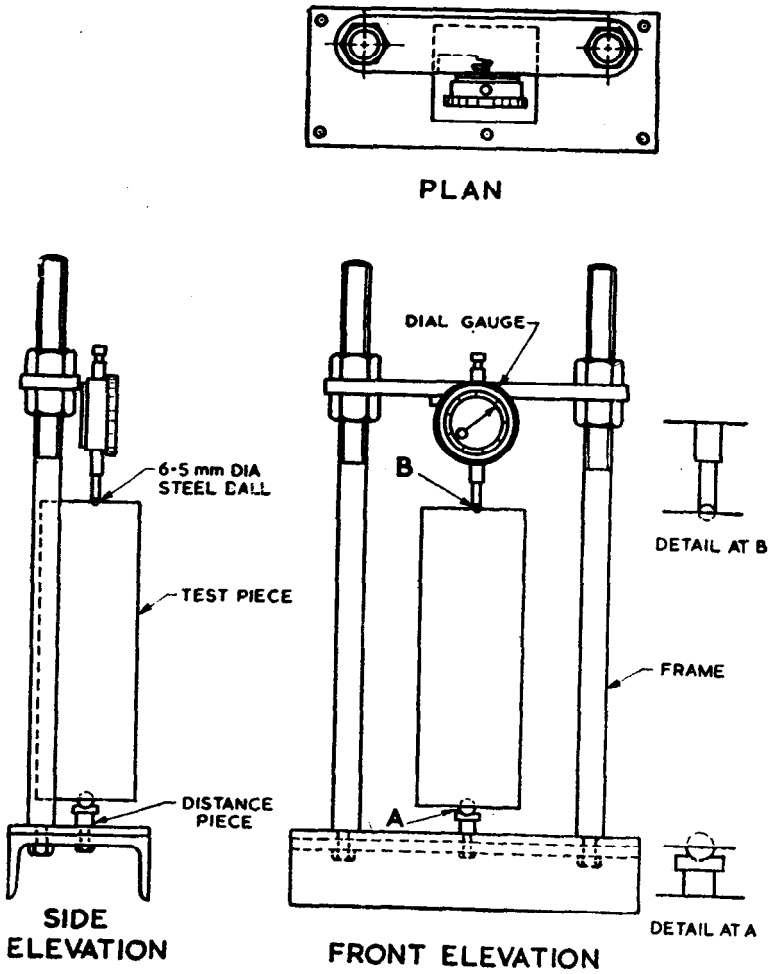

FIG. 11 TYPICAL APPARATUS FOR DRYING SHRINKAGE AND MOISTURE MOVEMENT TESTS

after drilling or cutting a shallow depression. After fixing, the surface of the balls shall be wiped clean of cement, dried, and coated with lubricating grease to prevent corrosion. The specimen shall be kept moist for at least 24 hours after fixing the balls, in order to allow the cement to harden. At the conclusion of the period of storage in moist air, the specimen shall be immersed in water at a temperature of 24 to 30°C until 28 days after the concrete has been made, or until such other time as may be specified.

**10.3.2 Matured Specimens** — When the test is carried out on a specimen cut from matured concrete or on a specimen which has not had the controlled curing indicated in 10.3.1, the balls or other reference points shall be fixed and greased as described in 10.3.1 and the specimen kept moist for at least 24 hours after fixing the balls. The specimen shall then be immersed in water at 24 to 30°C in such a manner that one of the larger faces of the specimen just breaks surface in the water and left so immersed for four days.

**10.4 Procedure for Testing for Initial Drying Shrinkage or Drying Shrinkage** — Immediately after removal of the specimen from the water, the grease shall be wiped from the balls and the length of the specimen measured to an accuracy of 0.005 mm by the apparatus described in 10.2.1. This shall be taken as the 'original wet measurement'.

NOTE — The instrument reading required is not the absolute length of the specimen but the difference in length between the specimen and an invar rod of approximately the same length.

The specimen shall then be dried in the oven as described under 10.2.2 at the specified temperature and humidity for at least 44 hours. The specimen shall then be removed from the oven and cooled for at least four hours in a desiccator containing solid calcium chloride in a saturated solution of calcium chloride. The length of the specimen shall then be measured as described above at a temperature of 24 to 30°C.

NOTE — If measurements are made at temperatures other than 25°C, they should be reduced by 0.002 percent of the dry length for each 2°C above 25°C.

**10.4.1** The cycle of drying, cooling and measuring shall be repeated until constant length is attained, that is, when the difference between two consecutive readings separated by a period of drying of at least 44 hours, followed by cooling for at least four hours, is less than 0.01 mm for a 15 cm specimen, and proportionately greater for a larger specimen. The final reading shall be taken as the dry measurement. During the above drying process, further wet specimens shall not be placed in the same oven, and there shall be a free access of air to all surfaces of the specimens.

**10.4.2** After the dry measurement has been taken, the length of the specimen shall be measured, adjacent to the balls, to the nearest 0.5 mm and this shall be taken as the 'dry length'. The 'initial drying shrinkage'

or the 'drying shrinkage' shall be calculated as the difference between the 'original wet measurement' and the 'dry measurement' expressed as a percentage of the 'dry length'.

**10.5 Determination of Moisture Movement** — For the determination of the moisture movement, the specimen shall first be tested for initial drying shrinkage or drying shrinkage as described above and the dry measurement determined. The specimen shall then be immersed in water at 24 to 30°C in such a manner that one of the larger faces of the specimen just breaks surface in the water and shall be left so immersed for four days after which the 'final wet measurement' shall be determined. The moisture movement shall be calculated as the difference between the 'dry measurement' and 'final wet measurement' expressed as percentage of the 'dry length'.

**10.6 Report** — The following information shall be included in the report:

- a) Identification mark,
- b) Date of starting test,
- c) Age of specimen at beginning of test,
- d) Size of specimen,
- e) Curing conditions,
- f) Initial drying shrinkage or drying shrinkage,
- g) Moisture movement, if determined, and
- h) Remarks, such as, time to reach constant length.

# BUREAU OF INDIAN STANDARDS

## Headquarters:

Manak Bhavan, 9 Bahadur Shah Zafar Marg, NEW DELHI 110002

Telephones : 331 01 31, 331 13 75

Telegrams : Manaksanstha  
(Common to all offices)

## Regional Offices:

	<i>Telephones</i>
Central : Manak Bhavan, 9 Bahadur Shah Zafar Marg, NEW DELHI-110002	[331 01 31 331 13 75
*Eastern : 1/14 C.I.T. Scheme VII M, V. I. P. Road, Maniktola, CALCUTTA 700054	36 24 99
Northern : SCO 445-446, Sector 35-C, CHANDIGARH 160036	[2 18 43 3 16 41
Southern : C. I. T. Campus, MADRAS 600113	{41 24 42 41 25 19 41 29 16
†Western : Manakalaya, E9 MIDC, Marol, Andheri (East), BOMBAY 400093	6 32 92 95

## Branch Offices:

'Pushpak' Nurmohamed Shaikh Marg, Khanpur, AHMEDABAD 380001	[2 63 48 2 63 49
‡Peenya Industrial Area, 1st Stage, Bangalore Tumkur Road BANGALORE 560058	[38 49 55 38 49 56
Gangotri Complex, 5th Floor, Bhadbhada Road, T. T. Nagar, BHOPAL 462003	6 67 16
Plot No. 82/83, Lewis Road, BHUBANESHWAR 751002	5 36 27
53/5, Ward No. 29, R. G. Barua Road, 5th Byelane, GUWAHATI 781003	3 31 77
5-8-56C L. N. Gupta Marg ( Nampally Station Road ), HYDERABAD 500001	23 10 83
R14 Yudhister Marg, C Scheme, JAIPUR 302005	[6 34 71 6 98 32
117/418 B Sarvodaya Nagar, KANPUR 208005	[21 68 76 21 82 92
Patliputra Industrial Estate, PATNA 800013	6 23 05
T.C. No. 14/1421, University P.O., Palayam TRIVANDRUM 695035	[6 21 04 6 21 17

## Inspection Office (With Sale Point) :

Pushpanjali, 1st Floor, 205-A West High Court Road, Shankar Nagar Square, NAGPUR 440010	2 51 71
Institution of Engineers (India) Building, 1332 Shivaji Nagar, PUNE 411005	5 24 35

\*Sales Office in Calcutta is at 5 Chowringhee Approach, P.O. Princep Street, Calcutta 700072 27 68 00

†Sales Office in Bombay is at Novelty Chambers, Grant Road, Bombay 400007 89 65 28

‡Sales Office in Bangalore is at Unity Building, Narasimharaja Square Bangalore 560002 22 36 71