

IS : 9893 - 1981

*Indian Standard*  
SPECIFICATION FOR  
PRECAST CONCRETE LINTELS AND SILLS

UDC 69.022.99 : 666.977



© Copyright 1982

**INDIAN STANDARDS INSTITUTION**  
MANAK BHAVAN, 9 BAHADUR SHAH ZAFAR MARG  
NEW DELHI 110002

Price Rs. 7.00

Gr. 4

April 1982

# Indian Standard

## SPECIFICATION FOR PRECAST CONCRETE LINTELS AND SILLS

Cement and Concrete Sectional Committee, BDC 2

*Chairman*

DR H. C. VISVESVARAYA

*Representing*

Cement Research Institute of India, New Delhi

*Members*

ADDITIONAL DIRECTOR, STANDARDS ( B & S )	Research, Designs & Standards Organization ( Ministry of Railways ), Lucknow
DEPUTY DIRECTOR, STANDARDS ( B & S ) ( <i>Alternate</i> )	
SHRI K. P. BANERJEE	Larsen & Toubro Ltd, Bombay
SHRI HARISH N. MALANI ( <i>Alternate</i> )	
SHRI S. K. BANERJEE	National Test House, Calcutta
SHRI R. N. BANSAL	Beas Designs Organization, Nangal Township
SHRI T. C. GARG ( <i>Alternate</i> )	
CHIEF ENGINEER ( DESIGNS )	Central Public Works Department, New Delhi
EXECUTIVE ENGINEER ( DESIGNS ) III ( <i>Alternate</i> )	
CHIEF ENGINEER ( PROJECTS )	Irrigation Department, Government of Punjab, Chandigarh
DIRECTOR, IPRI ( <i>Alternate</i> )	
DIRECTOR ( CSMRS )	Central Water Commission, New Delhi
DEPUTY DIRECTOR ( CSMRS ) ( <i>Alternate</i> )	
DR R. K. GHOSH	Central Road Research Institute ( CSIR ), New Delhi
SHRI Y. R. PHULL ( <i>Alternate</i> I )	
SHRI M. DINAKARAN ( <i>Alternate</i> II )	
DR R. K. GHOSH	Indian Roads Congress, New Delhi
SHRI A. K. GUPTA	Hyderabad Asbestos Cement Products Ltd, Hyderabad
SHRI V. K. GUPTA	Engineer-in-Chief's Branch, Army Headquarters
SHRI S. N. PANDE ( <i>Alternate</i> )	
DR R. R. HATTIANGADI	The Associated Cement Companies Ltd, Bombay
SHRI P. J. JAGUS ( <i>Alternate</i> )	
DR IQBAL ALI	Engineering Research Laboratories, Hyderabad
SHRI S. R. KULKARNI	M. N. Dastur & Co Pvt Ltd, Calcutta
SHRI S. K. LAHA	The Institution of Engineers ( India ), Calcutta
SHRI B. T. UNWALLA ( <i>Alternate</i> )	
DR MOHAN RAI	Central Building Research Institute ( CSIR ), Roorkee
DR S. S. REHSI ( <i>Alternate</i> )	

( *Continued on page 2* )

© Copyright 1982

INDIAN STANDARDS INSTITUTION

This publication is protected under the *Indian Copyright Act* ( XIV of 1957 ) and reproduction in whole or in part by any means except with written permission of the publisher shall be deemed to be an infringement of copyright under the said Act.

(Continued from page 1)

<i>Members</i>	<i>Representing</i>
SHRI K. K. NAMBIAR	In personal capacity ('Ramanalaya' II First Crescent Park Road, Gandhinagar, Adyar, Madras)
SHRI H. S. PASRICHA	Hindustan Prefab Ltd, New Delhi
SHRI C. S. MISHRA ( <i>Alternate</i> )	
DR M. RAMAIAH	Structural Engineering Research Centre (CSIR), Roorkee
DR N. S. BHAL ( <i>Alternate</i> )	
SHRI G. RAMDAS	Directorate General of Supplies and Disposals, New Delhi
DR A. V. R. RAO	National Buildings Organization, New Delhi
SHRI J. SEN GUPTA ( <i>Alternate</i> )	
SHRI R. V. CHALAPATHI RAO	Geological Survey of India, Calcutta
SHRI S. ROY ( <i>Alternate</i> )	
SHRI T. N. S. RAO	Gammon India Ltd, Bombay
SHRI S. R. PINHEIRO ( <i>Alternate</i> )	
SHRI ARJUN RIJHSINGHANI	Cement Corporation of India Ltd, New Delhi
SHRI K. VITHAL RAO ( <i>Alternate</i> )	
SECRETARY	Central Board of Irrigation and Power, New Delhi
DEPUTY SECRETARY (I) ( <i>Alternate</i> )	
SHRI N. SIVAGURU	Roads Wing, Ministry of Shipping and Transport
SHRI R. L. KAPOOR ( <i>Alternate</i> )	
SHRI K. A. SUBRAMANIAM	The India Cements Ltd, Madras
SHRI P. S. RAMACHANDRAN ( <i>Alternate</i> )	
SUPERINTENDING ENGINEER (DESIGNS)	Public Works Department, Government of Tamil Nadu, Madras
EXECUTIVE ENGINEER (S M & R DIVISION) ( <i>Alternate</i> )	
SHRI L. SWAROOP	Dalmia Cement (Bharat) Ltd, New Delhi
SHRI A. V. RAMANA ( <i>Alternate</i> )	
SHRI B. T. UNWALLA	The Concrete Association of India, Bombay
SHRI Y. K. MEHTA ( <i>Alternate</i> )	
SHRI G. RAMAN, Director (Civ Engg)	Director General, ISI ( <i>Ex-officio Member</i> )

*Secretary*

SHRI M. N. NEELAKANDHAN  
Assistant Director (Civ Engg), ISI

Precast Concrete Products Subcommittee, BDC 2 : 9

*Members*

DEPUTY DIRECTOR, STANDARDS (B & S)	Research, Designs & Standards Organization (Ministry of Railways), Lucknow
ASSISTANT DIRECTOR, STANDARDS (B & S) II ( <i>Alternate</i> )	
DIRECTOR (CSMRS)	Central Water Commission, New Delhi
DEPUTY DIRECTOR (CSMRS) ( <i>Alternate</i> )	
GENERAL MANAGER (CCP)	Tamil Nadu Housing Board, Madras
PROJECT OFFICER (CCP) ( <i>Alternate</i> )	

(Continued on page 15)

# *Indian Standard*

## SPECIFICATION FOR PRECAST CONCRETE LINTELS AND SILLS

### 0. FOREWORD

**0.1** This Indian Standard was adopted by the Indian Standards Institution on 30 June 1981, after the draft finalized by the Cement and Concrete Sectional Committee had been approved by the Civil Engineering Division Council.

**0.2** This standard covers the requirements of precast concrete lintels and sills. Use of precast concrete products in building construction has a number of advantages over cast-in-situ concrete, especially with regard to the quality of construction and period of construction.

**0.2.1** Additional details pertaining to thin precast reinforced concrete lintels are given in 'Data Sheet No. 1 — Thin Precast R.C.C. Lintel in Brick-Wall-Building Technique Series' published by the Central Building Research Institute, Roorkee.

**0.3** The precast concrete lintels and sills covered in this standard are intended primarily for use in residential buildings; but their use is not thus restricted.

**0.4** For the purpose of deciding whether a particular requirement of this standard is complied with, the final value, observed or calculated, expressing the result of a test or analysis, shall be rounded off in accordance with IS : 2-1960\*. The number of significant places retained in the rounded off value should be the same as that of the specified value in this standard.

### 1. SCOPE

**1.1** This standard covers the requirements of precast concrete lintels and sills.

### 2. SHAPE AND DIMENSIONS

#### 2.1 Lintels

**2.1.1 Reinforced Concrete Lintels** — Reinforced concrete lintels may be precast in one piece or in two pieces as a split lintel ( *see* Fig. 1 ).

\*Rules for rounding off numerical values ( *revised* ).

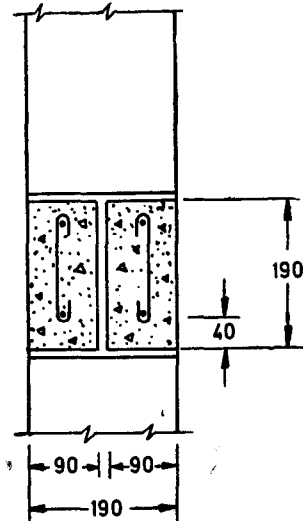

All dimensions in millimetres.  
**FIG. 1 SPLIT LINTEL**

The latter is lighter in mass, easier to handle and the air space between the pieces affords insulation which is desirable especially if furring is not provided. Split lintels are quite satisfactory and are even desirable when they support wall loads only. However, when joists or beams bear on the lintels, it shall be made in one piece as it is practically impossible to design the inner section of a split lintel carrying both wall and floor loads, to have the same deflection as the outer section which carries wall load only. Differences in deflection of the two pieces would, probably result in cracks in the masonry wall above.

NOTE — Lintel-cum-sunshades (see Fig. 2) for use over door, window and ventilator openings of exterior walls in buildings may also be precast; but care should be taken to see that these units do not become too heavy or unwieldy for handling and lifting purposes.

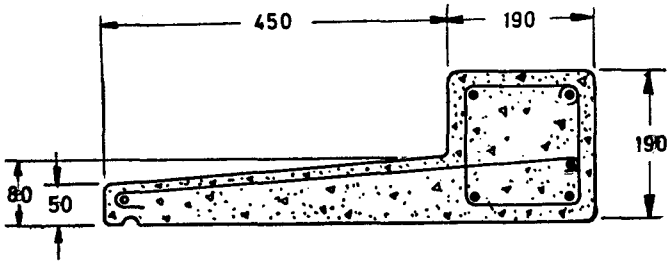

NOTE — For details of throating, Fig. 7 may be repeated to.  
 All dimensions in millimetres.

**FIG. 2 LINTEL-CUM-SUNSHADE**

**2.1.2 U-Shaped Lintels** — U-shaped lintels (see Fig. 3) are precast by stringing together U-shaped concrete masonry units as forms, and then placing reinforcement and pouring concrete to fill the forms. These lintels have the advantage of conforming with the general bond pattern and surface texture of the surrounding masonry.

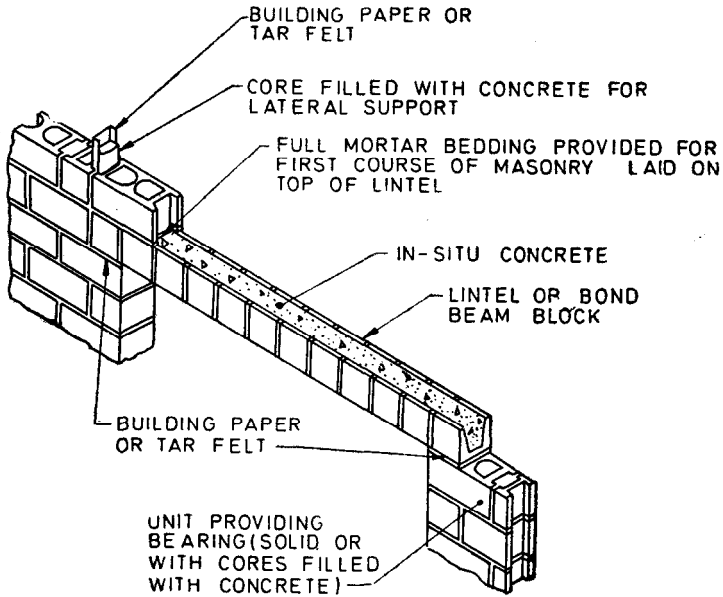

All dimensions in millimetres.

FIG. 3 TYPICAL DETAILS OF A U-SHAPED MASONRY LINTEL

**2.1.3 Lintel Bearing** — Reinforced concrete lintels for doors and windows shall be well bonded into the masonry on either side of the opening. It is advisable to provide a bearing length approximately equal to the depth of the lintel. Provision of suitable bearings for lintels helps to prevent cracking at the corners of such openings.

**2.1.4 Throatings** — A 16 mm wide throating as shown in Fig. 4 shall be provided to the soffit of external lintels.

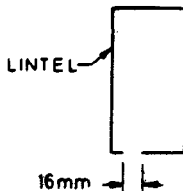

NOTE — For details of throating, Fig. 7 may be referred to.

FIG. 4 POSITION AND SIZE OF THROATING OF LINTEL

**2.1.5 Inserts for Lintels** — Provision shall be made for fixing screws to windows, door frames, curtain and blind fittings, etc, by means of timber or pre-formed inserts incorporated in the lintels during course of manufacture or by the forming of holes for inserts. In all cases, inserts shall be of suitable resilient or fibrous material of types satisfactory for external exposure.

Timber inserts shall be capable of taking and holding screws and shall be cast into the surface of the lintel in predetermined positions for external and internal lintels.

Where preformed inserts of suitable resilient or fibrous material are used, holes shall be provided in predetermined positions or inserts may be included when the lintels are cast; in which case they shall be dovetailed in section.

**2.1.6** The cross-sectional dimensions and reinforcement shall be adequate to conform to the design requirements.

## 2.2 Sills

**2.2.1 General** — There are two general types of sills in common use — the slip sill and the lug sill. Both types are sloped on the top face to drain water away quickly. If projections are provided, they should project at least 40 mm beyond wall face and be provided with a groove along the lower outer edge to provide a drip. Lengths up to 1 m may be cast in one piece; longer lengths may be cast in two or more pieces.

**2.2.1.1 Slip sills** — Slip sills (see Fig. 5) are inserted after the wall proper has been built and therefore require no protection during construction. Since there is an exposed joint at each end of the sill, special care shall be taken to fill it completely with mortar, packing the joints tight.

**2.2.1.2 Lug sills** — Lug sills (see Fig. 6) are those with the ends projecting into the masonry wall. There are no vertical joints at the juncture of the sills and the jambs which is one of the advantages of the lug sill over the slip sill. Frequently they are made with washes at either end to divert water away from the jambs and this is a desirable feature.

NOTE — At the time lug sills are set, only the portion projecting into the wall is bedded in mortar. The portion immediately below the wall opening is left free of contact with the wall below. This is done so that in case there is a minor settlement or adjustment in the masonry work during construction, the sill will be free to adapt itself to such minor wall movements, thus avoiding possible damage to the sill during the construction period. The space between the sill and the wall below is filled with mortar and pointed after the exterior walls have been built.

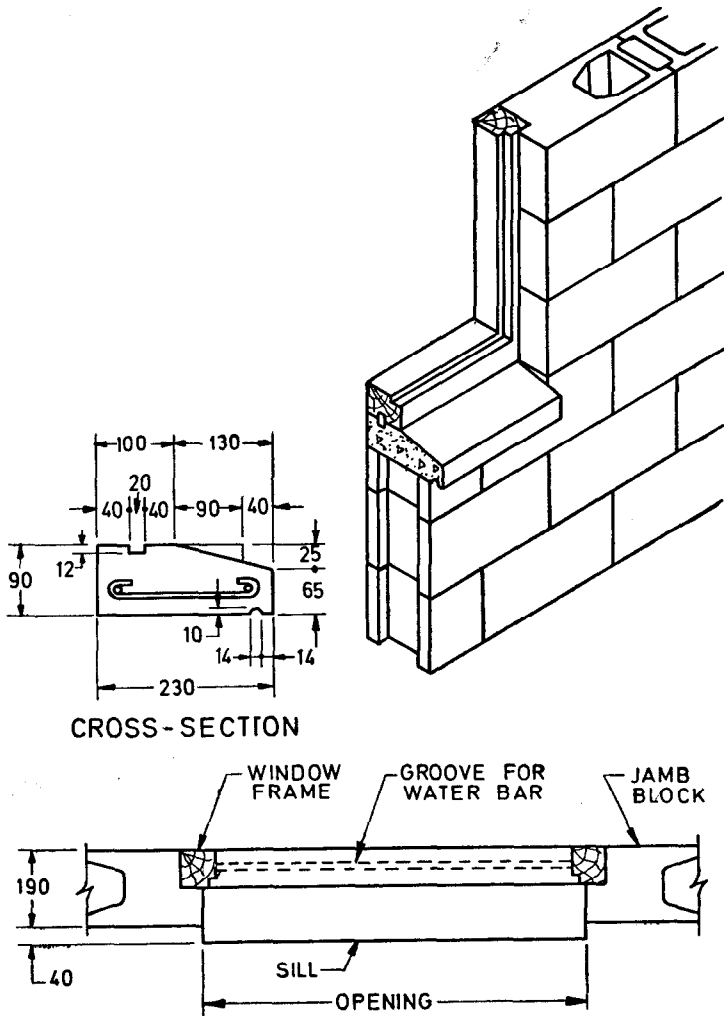

CROSS-SECTION

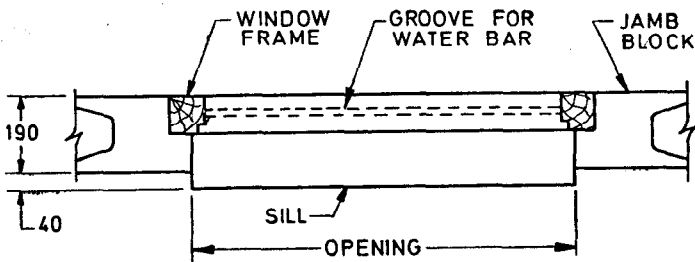

All dimensions in millimetres.

FIG. 5 TYPICAL DETAILS OF A PRECAST CONCRETE SLIP SILL

**2.2.2 Dowell Holes for Sills** — Concrete sills to take metal windows shall be provided with holes 20 mm diameter and 32 mm deep at prescribed distances from each end.

**2.2.3 Projection of Sills** — The projections of sills, when provided, shall be not less than 40 mm from the finished wall face.



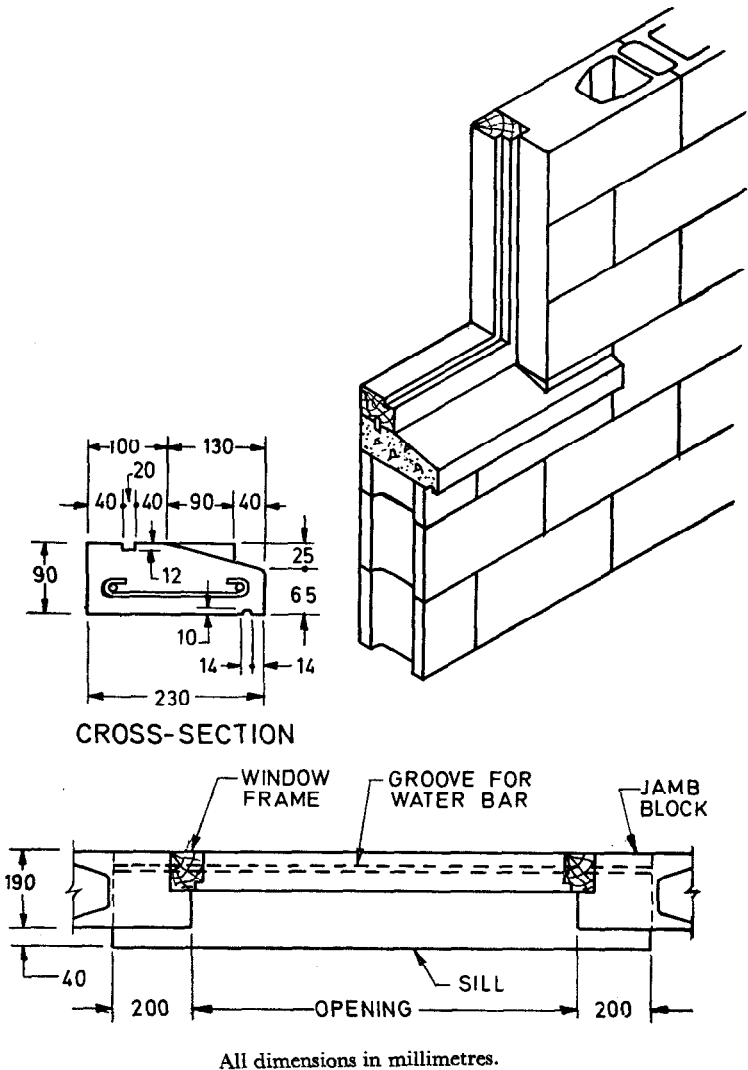
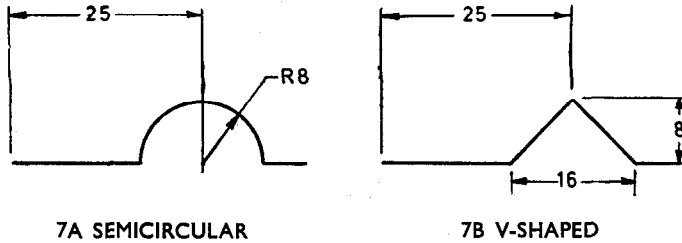

FIG. 6 TYPICAL DETAILS OF A PRECAST CONCRETE LUG SILL

**2.2.4 Throatings** — Throatings to precast concrete sills may be semi-circular or V-shaped as shown in Fig. 7.



All dimensions in millimetres.

FIG. 7 POSITION AND SIZE OF THROATING TO SILL

**2.3 Tolerances** — For lintels, a tolerance of  $\pm 0.2$  mm shall be allowed on cross-sectional dimensions and  $\pm 6$  mm on the length. In case of sills, a tolerance of  $\pm 0.8$  mm shall be allowed on the cross-sectional dimensions and  $\pm 3$  mm on the length.

### 3. MATERIALS

**3.1 Cement** — The cement used shall be any of the following with the prior approval of the engineer-in-charge:

- a) Ordinary Portland cement conforming to IS : 269-1976\*,
- b) Portland slag cement conforming to IS : 455-1976†,
- c) Portland pozzolana cement conforming to IS : 1489-1976‡,
- d) Rapid-hardening Portland cement conforming to IS : 8041-1978§,
- e) High strength ordinary Portland cement conforming to IS : 8112-1976||, and
- f) Hydrophobic cement conforming to IS : 8093-1978¶.

**3.2 Aggregates** — Aggregates shall comply with the requirements of IS : 383-1970\*\*. The aggregate crushing value, when determined in accordance with IS : 2386 (Part IV)-1963†† shall not exceed 45 percent. The nominal maximum size of aggregate shall not exceed 12.5 mm for lintels and 10 mm for sills.

\*Specification for ordinary and low heat Portland cement (third revision).

†Specification for Portland slag cement (third revision).

‡Specification for Portland Pozzolana cement (second revision).

§Specification for rapid-hardening Portland cement.

||Specification for high strength ordinary Portland cement.

¶Specification for hydrophobic Portland cement (first revision).

\*\*Specification for coarse and fine aggregates from natural sources for concrete (second revision).

††Methods of test for aggregates for concrete : Part IV Mechanical properties.

**3.3 Water** — The water used shall conform to the requirements specified in IS : 456-1978\*.

**3.4 Pozzolana** — Pozzolanic materials conforming to relevant Indian Standards may be used for part replacement of unblended cements or as an admixture.

**3.5 Reinforcement** — The reinforcement for lintels shall consist of mild steel and medium tensile steel bars conforming to IS : 432 ( Part I )-1966† or hard drawn steel wire conforming to IS : 432 ( Part II )-1966‡ or hot rolled deformed bars conforming to IS : 1139-1966§ or high strength deformed bars conforming to IS : 1786-1979||.

**3.5.1 Reinforcement** shall be free from loose mill scales, loose rust, coats of paints, oil, mud, and any other coating which could reduce the bond between the concrete and the steel. A slight film of rust shall not be regarded as harmful, but the steel shall not be visibly pitted by rust.

**3.6 Concrete** — The mix proportions shall be determined by the manufacturer and shall be such as will produce a dense concrete, but shall not be weaker than M 20 grades ( see IS : 456-1978\* ). Production and control of concrete shall be in accordance with IS : 456-1978\*.

## 4. DESIGN

**4.1 Method of Design** — The design of lintels and sills shall be based on IS : 456-1978\*.

NOTE — Lintels more than 2.5 m in length shall be checked for deflection and when necessary, their depths shall be increased.

## 5. MANUFACTURE

**5.1 Construction and Finish** — The lintels and sills shall be made of concrete proportioned, mixed, placed and compacted to give a dense concrete free from voids ( see IS : 456-1978\* ). The lintels and sills shall have a dense surface finish showing no coarse aggregate, and shall have no crevices likely to assist in the disintegration of concrete or rusting of the steel by the action of natural agencies.

---

\*Code of practice for plain and reinforced concrete ( *third revision* ).

†Specification for mild steel and medium tensile steel bars and hard-drawn steel wire for concrete reinforcement: Part I Mild steel and medium tensile steel bars ( *second revision* ).

‡Specification for mild steel and medium tensile steel bars and hard-drawn steel wire for concrete reinforcement: Part II Hard-drawn steel wire ( *second revision* ).

§ Specification for hot rolled mild steel, medium tensile steel and high yield strength steel deformed bars for concrete reinforcement ( *revised* ).

|| Specification for cold-worked steel high strength deformed bars for concrete reinforcement ( *second revision* ).

**5.2 Freedom from Defects** — The arrises shall be clean and sharp and the exposed surfaces of all lintels and sills shall be plain, true and free from all blemishes. The interior of the lintels and sills shall when fractured present a clean homogeneous appearance.

**5.3 Moulds** — Where a number of lintels and sills are required to be cast, a multiple mould is economical. The usual precautions in making moulds for precast products should be taken to ensure that the sides do not go out of shape due to the pressure exerted by the wet concrete.

**5.4 Detailing of Reinforcement** — Requirements governing reinforcement and detailing shall be in accordance with IS : 456-1978\*. The reinforcement may be provided for sills to take care of handling stresses, where considered necessary by the manufacturer.

**5.5 Curing** — After placing, the concrete shall be adequately protected, during setting and in the first stages of hardening, from shocks, running or surface water and the harmful effects of sunshine, drying winds and cold. The concrete shall be cured for at least 7 days unless special curing methods are adopted.

NOTE — Steam curing of concrete may be adopted if so desired by the manufacturer, provided the requirements of pressure or non-pressure steam curing are fulfilled. For non-pressure steam curing, the following procedure may be adopted.

The lintels and sills shall be subjected to the action of thoroughly saturated steam at a temperature of 60 to 80°C for a period of 16 to 18 hours; or when necessary, for such additional time as may be necessary to enable them to meet the strength requirements. When a curing chamber is not available, they shall be placed in an enclosure of canvas or other closely woven material and subjected to saturated steam at the temperature and for the time specified. The enclosure shall be so erected as to allow full circulation of steam around the entire lintels and sills. The interior surface of the curing room or canvas jacket and their surfaces shall be entirely moist at all times.

**5.5.1** The lintels and sills shall be cured under such conditions as will ensure that they will meet the requirements of 3.6 and that the greater proportion of the irreversible shrinkage shall have occurred before they are delivered at site. Precautions shall also be taken to prevent them from drying out too quickly.

**5.5.2 Maturing** — From the date of casting, the lintels and sills shall be matured for the following period before testing or despatch including the period of curing:

*Cement used*

Ordinary Portland cement, Portland slag cement or Portland pozzolana cement	28 days
Rapid-hardening Portland cement	14 days

---

\*Code of practice for plain and reinforced concrete (*third revision*).

**5.5.3 Minimum Strength of Concrete for Handling** — At first handling the concrete shall have reached a strength at least twice the stress to which concrete may be subjected at the time of handling. The strength referred to shall be that of concrete using the same cement and aggregates, with the same proportions and cured under conditions of temperature and moisture similar to those existing at casting yard.

## 6. LIFTING

**6.1** The recommended method of lifting precast concrete lintels and sills is by means of a cradle made up of stout timber planks, well-battened together on the underside, care being taken to prevent the lintels and sills from being subjected to impact.

**6.2** Large and heavy lintels and sills should be lifted from their ends by slinging them from hooks embedded in the concrete and protruding 25 mm above their top surfaces.

## 7. STRENGTH REQUIREMENT

**7.1** The samples of lintels ( *see* 8 ) shall be tested in the condition as received in accordance with **7.1.1**.

**7.1.1** Each lintel to be tested shall be symmetrically supported on the bed face upon two self aligning steel bearers 38 mm diameter spaced, ( centre to centre ) at the appropriate clear span. The load shall be symmetrically applied through two 38 mm diameter steel bearers at quarter span points and resting across the width of the lintel parallel to the supports. The length of the bearers and supports shall be not less than the width of the lintel to be tested. The load shall be applied at a uniform rate of  $2 \pm 0.2$  kN till failure occurs.

**7.2** The ultimate breaking load obtained as per **7.1.1** shall not be less than the ultimate load which the lintel is designed to carry.

## 8. SAMPLING AND CRITERIA FOR CONFORMITY

### 8.1 Scale of Sampling

**8.1.1 Lot** — In any batch, all products of the same type and same dimensions shall be grouped together to constitute a lot.

**8.1.1.1 Sub-lot** — If the number of products in a lot exceed 500, the lot shall be divided into a suitable number of sub-lots such that the number of frames in any sub-lot shall not exceed 500. The acceptance or otherwise of a sub-lot shall be determined on the basis of sample selected from it.

**8.1.1.2** The number of products to be selected from a lot or a sub-lot shall depend upon its size and shall be in accordance with Table 1.

**TABLE 1 SAMPLE SIZE AND CRITERIA FOR CONFORMITY**

SIZE OF LOT OR SUB-LOT	DIMENSIONAL REQUIREMENTS		NO. OF LINTELS FOR STRENGTH TEST
	Sample Size	Permissible No. of Defectives	
(1)	(2)	(3)	(4)
Up to 100	10	1	1
101 to 200	15	1	2
201 to 300	20	2	2
301 to 500	30	3	3

**8.1.1.3** The products shall be selected at random. In order to ensure randomness, all the products in the lot or the sub-lot may be arranged in a serial order and starting from any products every  $r$ th frame may be included in the sample,  $r$  being the integral part of  $N/n$ , where  $N$  is the size of the lot or the sub-lot and  $n$  the sample size.

## 8.2 Number of Tests

**8.2.1** All the products as selected in **8.1.1.2** shall be tested for overall length, cross-section and uniformity.

**8.2.2** The number of lintels to be tested for strength (*see 7*) shall be in accordance with Table 1. These may be selected from those already tested as in **8.2.1**.

## 8.3 Criteria for Conformity

**8.3.1** A lot or a sub-lot shall be considered as conforming to this specification if the conditions under **8.3.2** are satisfied.

**8.3.2** The number of products which do not satisfy the requirements of overall length, cross section and uprightness shall not exceed the corresponding number given in Table 1. If the number of such products exceed the corresponding number, all products in the lot or sub-lot shall be tested for these requirements and those not satisfying the requirements shall be rejected.

**8.3.3** All lintels tested for strength shall satisfy the requirements of the test (*see 7.2*). If one or more units fail, twice the number of units originally tested shall be selected from those already selected, and subjected to the test. If there is no failure among these products, the lot or the sub-lot shall be considered to have satisfied the requirements of strength test.

## **9. MANUFACTURER'S CERTIFICATE AND COST OF TESTING**

**9.1** The manufacturer shall satisfy himself that his products comply with the requirements of this Indian Standard, and if requested, shall forward a certificate to this effect to the purchaser.

**9.2** If the purchaser requires independent tests, the samples shall be taken before delivery, and the tests shall be carried out in accordance with this specification on the written instructions of the purchaser.

**9.3** Unless otherwise specified, the cost of tests ( including the cost of samples ) shall be borne as follows:

- a) By the manufacturer in the event of results showing that the samples do not comply with this specification.
- b) By the purchaser in the event of the results showing that the samples comply with this specification.

## **10. MARKING**

**10.1** Lintels and sills shall be indelibly marked with the word 'TOP' on the top side so as to avoid their being placed in position upside down. In addition, the following information shall be clearly and indelibly marked on the lintels and sills.

- a) Manufacturer's name and or trade-mark if any, and
- b) Month and year of manufacture.

**10.2** The manufacturer shall provide technical literature containing information on:

- a) the ultimate load bearing capacity, and
- b) recommended clear span.

**10.3** Lintels and sills may also be marked with the ISI Certification Mark.

NOTE — The use of the ISI Certification Mark is governed by the provisions of the Indian Standards Institution ( Certification Marks ) Act and the Rules and Regulations made thereunder. The ISI Mark on products covered by an Indian Standard conveys the assurance that they have been produced to comply with the requirements of that standard under a well-defined system of inspection, testing and quality control which is devised and supervised by ISI and operated by the producer. ISI marked products are also continuously checked by ISI for conformity to that standard as a further safeguard. Details of conditions under which a licence for the use of the ISI Certification Mark may be granted to manufacturers or processors may be obtained from the Indian Standards Institution.

(Continued from page 2)

<i>Members</i>	<i>Representing</i>
SHRI Z. GEORGE	Structural Engineering Research Centre (CSIR), Madras
DR A. G. MADHAVA RAO ( <i>Alternate</i> )	
SHRI V. G. GOKHALE	Bombay Chemicals Pvt Ltd, Bombay
SHRI R. N. GREEN	Concrete Association of India, Bombay
SHRI N. C. DUGGAL ( <i>Alternate</i> )	
SHRI B. K. JINDAL	Central Building Research Institute (CSIR), Roorkee
DR S. S. REHSI ( <i>Alternate</i> )	
SHRI L. C. LAI	In personal capacity ( <i>B/17, West End, New Delhi</i> )
SHRI S. NAHARROY	Engineering Construction Corporation Ltd, Madras
SHRI A. RAMAKRISHNA ( <i>Alternate</i> )	
SHRI D. B. NAIK	Engineer-in-Chief's Branch, Army Headquarters
SHRI SUCHA SINGH ( <i>Alternate</i> )	
SHRI K. K. NAMBIAR	In personal capacity ( <i>'Ramanalaya', 11 First Crescent Park Road, Gandhinagar, Adyar, Madras</i> )
SHRI H. S. PASRICHA	Hindustan Prefab Ltd, New Delhi
DR N. RAGHAVENDRA	Cement Research Institute of India, New Delhi
SHRI V. RAMALINGAM	Neyveli Lignite Corporation Ltd, Neyveli
SHRI K. A. RAMABHADRAN ( <i>Alternate</i> )	
DR A. V. R. RAO	National Buildings Organization, New Delhi
SHRI J. SEN GUPTA ( <i>Alternate</i> )	
SHRI B. G. SHIRKE	B. G. Shirke & Co Pvt Ltd, Pune
SHRI U. S. DURGAKERI ( <i>Alternate</i> )	
SHRI C. N. SRINIVASAN	C. R. Narayana Rao, Madras
SHRI C. N. RAGHAVENDRAN ( <i>Alternate</i> )	
SUPERINTENDING SURVEYOR OF WORKS (NZ)	Central Public Works Department, New Delhi
SURVEYOR OF WORKS (NZ) ( <i>Alternate</i> )	



# INDIAN STANDARDS

ON

## PRECAST CONCRETE PRODUCTS

IS:

- 2174-1962 Reinforced concrete dust bins
- 2185 ( Part I )-1979 Concrete masonry units: Part I Hollow and solid concrete blocks  
( *second revision* )
- 3590-1966 Load bearing lightweight concrete blocks
- 4996-1968 Reinforced concrete fence posts
- 5482-1969 Autoclaved cellular concrete blocks
- 5751-1969 Precast concrete coping blocks
- 5758-1970 Precast concrete kerbs
- 5820-1970 Precast concrete cable covers
- 6041-1971 Code of practice for construction of autoclaved cellular concrete block masonry
- 6042-1969 Code of practice for construction of lightweight concrete block masonry
- 6072-1971 Autoclaved reinforced cellular concrete wall slabs
- 6073-1971 Autoclaved reinforced cellular concrete floor and roof slabs
- 6441 ( Part I )-1972 Methods of test for autoclaved cellular concrete products: Part I  
Determination of unit weight or bulk density and moisture content
- 6441 ( Part II )-1972 Methods of test for autoclaved cellular concrete products: Part II  
Determination of drying shrinkage
- 6441 ( Part IV )-1972 Methods of test for autoclaved cellular concrete products: Part IV  
Corrosion protection of steel reinforcement in autoclaved cellular concrete
- 6441 ( Part V )-1972 Methods of test for autoclaved cellular concrete products: Part V  
Determination of compressive strength
- 6441 ( Part VI )-1973 Methods of test for autoclaved cellular concrete products: Part VI  
Strength, deformation and cracking of flexural members subject to bending-  
short duration loading test
- 6441 ( Part VII )-1973 Methods of test for autoclaved cellular concrete products: Part VII  
Strength, deformation and cracking of flexural members subject to bending-  
sustained loading test
- 6441 ( Part VIII )-1973 Methods of test for autoclaved cellular concrete products:  
Part VIII Loading tests for flexural members in diagonal tension
- 6441 ( Part IX )-1973 Methods of test for autoclaved cellular concrete products: Part IX  
Jointing of autoclaved cellular concrete elements
- 6523-1972 Precast reinforced concrete door and window frames
- 9375-1979 Precast reinforced concrete plant guards



# AMENDMENT NO. 1      DECEMBER 1984

TO

## IS : 9893-1981 SPECIFICATION FOR PRECAST CONCRETE LINTELS AND SILLS

### **Alterations**

( *Page 3, clause 0.3* ) — Substitute the following for the existing clause:

**‘0.3** The precast lintels and sills covered in this standard are intended primarily for use in buildings.’

( *Page 5, clause 2.1.4* ) — Substitute the following for the existing matter:

**‘A** 16 mm wide throating as shown in Fig. 4 shall be provided along the outer edge of the soffit of external lintels.’

( *Page 12, clause 6.1* ) — Substitute the following for the existing clause:

**‘6.1** Precast concrete lintels and sills shall be lifted by means of a cradle made up of stout timber planks, well-battened together on the underside or any other suitable means not likely to damage the precast units, care being taken to prevent the lintels and sills from being subjected to impact.’

### **Addendum**

( *Page 12, clause 6.2* ) — Add the following sentence at the end:

**‘Flush** type hooks or inserts may also be used for lifting the lintels and sills.’

( BDC 2 )