

Indian Standard

**WELDING — COLD-WORKED STEEL BARS FOR
REINFORCED CONCRETE CONSTRUCTION —
RECOMMENDATIONS FOR WELDING**

(First Revision)

भारतीय मानक

वेल्डिंग — प्रबलित कंक्रीट संरचना के लिए अतप्त अभिकृत सरिये —
वेल्ड करने की सिफारिशें

(पहला पुनरीक्षण)

UDC 669·14-422-131·2 : 621·791 : 693·55

© BIS 1990

BUREAU OF INDIAN STANDARDS
MANAK BHAVAN, 9 BAHADUR SHAH ZAFAR MARG
NEW DELHI 110002

FOREWORD

This Indian Standard (First Revision) was adopted by the Bureau of Indian Standards on 13 February 1989, after the draft finalized by the Welding Application Sectional Committee had been approved by the Structural and Metals Division Council.

This standard was first published in 1977, deriving assistance from DIN 4099 (Part 1)-1972 'Welding of reinforcing steel— Requirements and tests', issued by the Deutsches Institut für Normung and keeping in view the practices prevailing in the country at that time.

In view of the experience gained over the years in the welding of cold-worked steel bars, the Committee has revised this standard by effecting the following major modifications:

- a) Resistance but welding of cold-worked bars has been deleted since it is no longer in use.
- b) A reference to gas pressure welding of cold-worked bars has been made. This technique although being extensively used in some foreign countries, is relatively new and yet to be commercially used in India.

This standard incorporates the provisions for the welding of cold-worked steel bars conforming to Grade Fe 415 and Fe 500 of IS 1786 : 1985. For welding micro alloyed steel bars, a reference may be made to IS 9595 : 1980 in regard to the provisions relating to carbon equivalent establishing welding procedures and other relevant details.

For the welding of thermo-mechanically treated bars, the provisions would be covered at a later date on necessary experience and data becoming available.

Provisions for welding of mild steel bars for reinforced concrete construction have been covered in IS 2751 : 1979.

Indian Standard

WELDING — COLD-WORKED STEEL BARS FOR REINFORCED CONCRETE CONSTRUCTION — RECOMMENDATIONS FOR WELDING

(*First Revision*)

1 SCOPE

1.1 This standard lays down recommendations for welding cold-worked steel bars conforming to Grade Fe 415 and Fe 500 of IS 1786 : 1985 'Specification for high strength deformed steel bars and wires for concrete reinforcements (*third revision*)' by flash butt welding, shielded metal arc welding and gas pressure welding processes.

2 REFERENCES

2.1 The Indian Standards listed in Annex A are necessary adjuncts to this standard.

3 TERMINOLOGY

3.1 For the purpose of this standard, definitions given in IS 812 : 1957 shall apply.

4 PLANS AND DRAWING

4.1 Plans and drawing for welding reinforced steel bars shall be prepared in accordance with SP 46 : 1988.

5 SYMBOLS

5.1 Symbols for welding used in plans and shop drawings shall conform to IS 813 : 1986.

6 WELDING EQUIPMENT AND ACCESSORIES

6.1 Welding equipment and accessories used in welding of steel bars for concrete reinforcement shall conform to the requirements of the appropriate Indian Standards where available. Where an Indian Standard is not available, equipment and accessories shall be of the best available quality. Their capacity shall be adequate for the welding procedure. A general guidance for selection of equipment and accessories is included in Annex B.

7 PARENT METAL

7.1 The parent metal shall be of guaranteed weldable quality of steel conforming to IS 1786 : 1985.

8 SAFETY AND HEALTH REQUIREMENTS

8.1 Safety and health requirements as prescribed in IS 818 : 1968 shall be applicable. Fire precautions shall be as given in IS 3016 : 1982.

9 ELECTRODES

9.1 Electrodes used shall conform to IS 814 (Part 1) : 1974.

10 WELDING PROCESSES AND PROCEDURES

10.1 General

10.1.1 Cold-worked steel bars shall be either butt welded or lap welded. Butt welding may be carried out either by flash butt, gas pressure or by shielded metal arc welding process. Lap welding may be carried out by shielded metal arc welding process.

10.1.2 Bars of unequal diameter may be welded. However, in case of butt welding, the difference in diameter of bars shall not exceed 5 mm. Where unequal diameter bars are welded, the dimension 'd' mentioned in this standard refers to the diameter of the smaller bar.

10.1.3 The untwisted ends must be removed before welding and the surface of the ends of the bars to be welded shall be clean and free from rust, paint, grease and/or other contaminants which are likely to affect the quality of weld.

10.2 Flash Butt Welding of Cold-Worked Bars

10.2.1 General

Flash butt welding may be adopted if a large number of welding has to be done at the same place and when the electric supply is available of the required capacity in respect of the cross sectional area of the maximum size of the bar to be welded.

10.2.2 Procedure

10.2.2.1 The ends of the bars to be welded should be placed in proper alignment in clamps so that bent or eccentric joints do not result. The clamps should be cleaned before each welding operation to avoid current loss and to eliminate harmful notches or grooves due to burning in of spots of arcing.

10.2.2.2 The bar ends shall be uniformly pushed against each other from the moment of contact to the up-setting. The transformer regulator should be so set that the current at the contact area is between 85 to 90 A/mm².

10.2.2.3 If the capacity of butt welding machine or the available power is not sufficient to take the load for welding from cold, welding may be done after preheating. By making and breaking of the contact arc repeatedly, heat can be made to spread over the entire cross section of the bar. The number of short-circuits (contacts and reversing) should be kept to the minimum possible so that the welding time and spread of heat in the longitudinal direction in the bar is minimum. Satisfactory joints with only slight reduction in original strength of the bar can be achieved with a current density up to 25 A/mm².

10.2.2.4 In automatic machines, the flash rate should be so set that a continuous flash without interruption can be achieved. If the rate is set, too high additional short-circuits are required leading to heat spread. If the rate is too low, the flash will be interrupted and consequently air penetrating into the joints will form oxides. If the machine is hand-operated, the flash should be maintained to avoid interruption. Too long flashes lead to generation of large quantities of heat thus removing the effect of cold-working in the bar.

10.2.2.5 For bars with sheared ends, a burn-off (flash-off) length of about 5 to 7 mm is required (this length is practically independent of the bar diameter). Very short burn-off lengths lead to defective welding because all the impurities may not have been removed from the place of welding. Increase in the burn-off length will spread heat along the length of the bar thus reducing the strength of the bar.

10.2.2.6 The up-setting should result from the burning off, that is, without interruption in the rain of sparks. The electric supply should be switched off about 1/3 to 1 second after the start of the up-setting or in the case of automatic machine after 1 to 3 mm of up-set travel.

The voltage and frequency of the current should be checked before commencing the welding

operation. Deviations from the nominal value or large fluctuations during the operation may lead to gross defects in welding. Wherever possible, welding should be done during day time when the total load on the network is fairly balanced.

10.3 Butt-Welding by Shielded Metal Arc Welding Process

10.3.1 General

Butt-welds by metal arc welding process are normally adopted to join bars of thickness more than 20 mm.

10.3.2 Preparation for Welding

10.3.2.1 The preparation of the edges of the rods shall be as shown in Fig 1. The edges shall be prepared by shearing, machining, or oxy-acetylene flame cutting. Beveling may be made by machining, grinding oxy-acetylene cutting. The fusion faces and the surrounding material shall be free from scale, dirt, greases, paint, rust and contaminants.

10.3.2.2 When it is not possible to rotate the bars for carrying out all welding in flat position, the edge preparation shall be such that welding is done on both sides in the vertical position.

10.3.2.3 All the bars to be butt welded should be aligned and set up in position with their axis in one straight line. This may be done in a jig or by means of a clamp or by using guides. Rotation of the bars should be avoided until they are adequately welded so that no disturbance to the alignment is caused and no twist is introduced in the bars during the process of welding. The joints may not be out of alignment by more than 25 percent of the thickness of the thinner material for material up to and including 12 mm thick, or by more than 3 mm for thicker material.

10.3.3 Electrode

10.3.3.1 Welding electrodes with flux covering of Type 3 or Type 6 of IS 815 : 1974 are

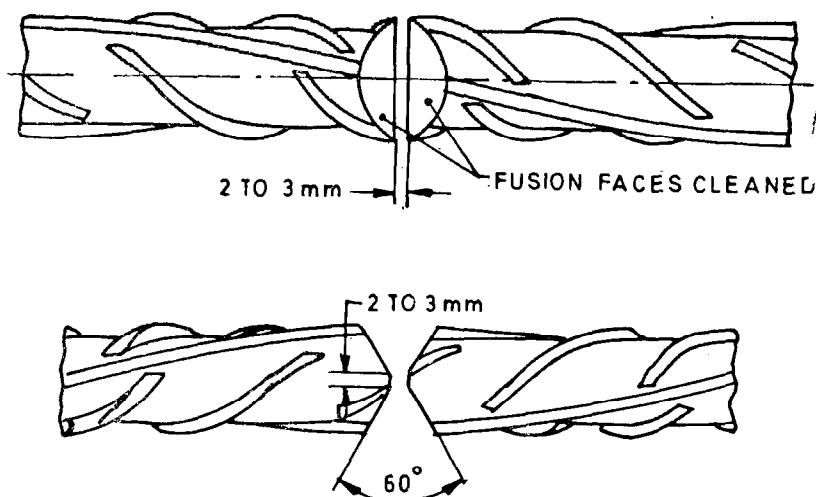

FIG. 1 EDGE PREPARATION

recommended for better results depending on the size of the bar to be welded. Storage of the latter type and their drying immediately prior to use must be strictly in accordance with the recommendation of the electrode manufacturer.

10.3.3.2 The size of electrodes depends upon the position of the bead and thickness of the bar to be welded. The root runs should be made with electrodes of size not exceeding 2.5 mm. For successive beads, the size of the electrodes should be progressively increased so that in the top bead, the electrode size does not generally exceed 3.15 mm for 20 mm bars and 5 mm for 40 mm bars.

10.3.3.3 Concentration of heat shall be avoided by proper welding sequence and manipulation of electrodes.

10.3.4 Procedure

10.3.4.1 The sequence of welding beads is shown in Fig. 2. The runs 1 to 4 are made in the position of welding best suited for the quality of the weld. Besides the interruption in welding required for cleaning of each bead, a pause shall be made after every second bead and the bar is allowed to cool. The temperature of the bars at a distance of about one bar diameter from the joints shall not exceed 300°C immediately after the bead is made. Before commencing the next bead, the temperature shall not exceed 250°C. The temperature may be checked approximately by using temperature indicating crayons. However, in the absence of temperature indicating devices, the bar may be allowed to cool down to handhot temperature before the next bead is deposited.

After completing bead 4, the bars are turned through 180° and the beads 5 to 7 are made in the same manner as described above. The top bead 8 is deposited as the joint is continuously rotated and the size of the reinforcement should be approximately as indicated in Fig. 2.

10.3.4.2 In the case of non-rotatable bars, the beads 1 to 4 should be made as explained in **10.3.4.1**. The welder then moves to the other side and beads 5 to 7 are similarly made. It is difficult to deposit a uniform top bead for non-rotatable bars and it may be necessary to make two or more separate annular runs so that the joint is approximately axisymmetric and has sufficient reinforcement as shown in Fig. 2.

10.4 Butt Welding by Gas Pressure Welding Process

10.4.1 Gas pressure welding is basically a hot forging process of joining the two bars end to end. The bar ends are heated by a multi-nozzle burner using oxy-acetylene flame and fused by forcing the two bar ends against each other under pressure to effect a solid phase welded joint.

10.4.2 Recommendations in regard to the preparation for welding procedure and equipment are given in Annex C.

10.5 Lap Welding of Cold-Worked Bars

10.5.1 General

Lap joints may be made in cold-worked bars of all sizes. They are preferred when access for welding is from one side only, and while connecting prefabricated units. Use of electrodes with flux covering of Type 3 or Type 6 of IS 815 : 1974 are recommended for better results depending on the size of bar being welded. Storage of the latter type and their drying immediately prior to use must be strictly in accordance with the recommendations of the electrode manufacturer.

10.5.2 Preparation for Welding

Edge preparation is not necessary for lap welds. The joint faces and the surrounding material shall be free from scale, dirt, grease, paint, rust and contaminants.

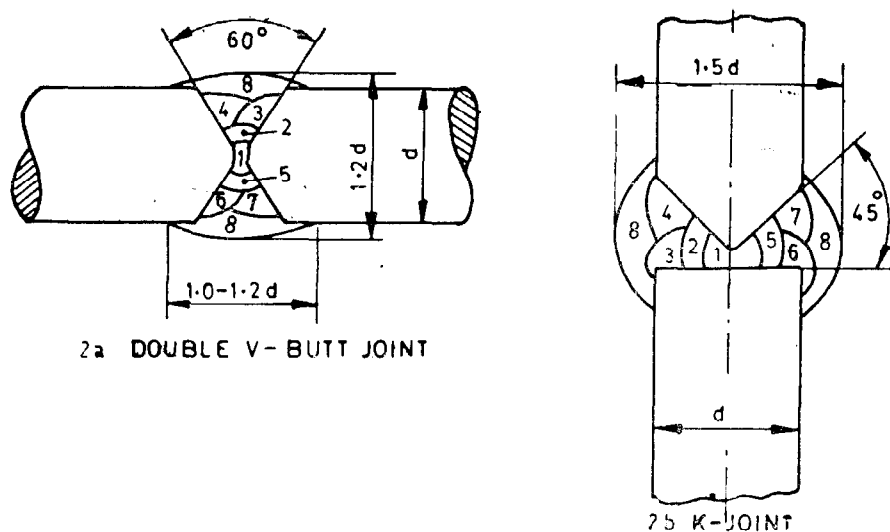

FIG. 2 SEQUENCE OF WELDING

10.5.3 Electrodes

The size of electrodes according to the diameter of the bar to be welded shall be as follows:

Nominal Diameter of Bar, d mm	Size of Electrode, Max mm
Up to and including 10	2.5
Over 10 up to and including 18	3.15
Over 18 up to and including 28	4.0
Over 28	5.0

10.5.4 Procedure

The arc should be struck as shown in Fig. 3

somewhere in the middle of the joint and not at its beginning.

The movement of the electrode for welding lap joints in the horizontal and vertical position is indicated in Fig. 3.

The various lap joints used to connect cold-worked bars are shown in Fig. 4 to 7.

In Fig. 4 to 6, the dimensions indicated as ' $5d$ ' for single side welding should be halved to ' $2.5d$ ' if the welds are deposited from the opposite side also. The single-strap arrangement shown in Fig. 7 is not recommended where access is from one side only. In the case of joints illustrated in Fig. 6 and 7, the strap material must also conform to 7 and the strap cross sectional area must, at least, equal that of the bar to be joined.

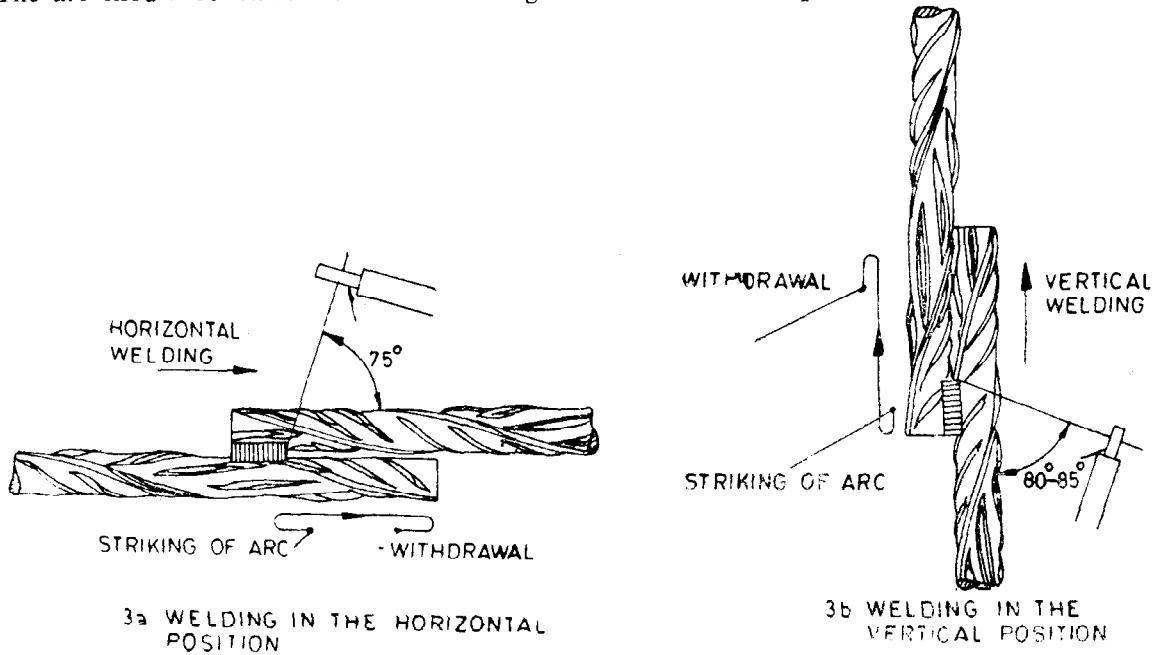
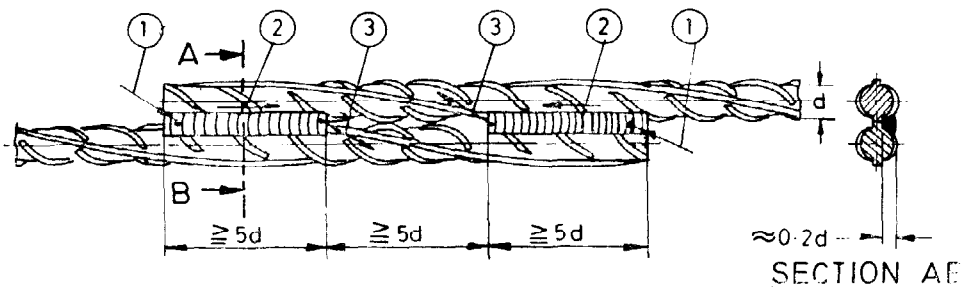

FIG. 3 WELDING OF LAP JOINTS



1. Strike the electrode here; the arc striking point must lie in the groove which will be subsequently welded-over.
2. Welding directions for horizontal or near-horizontal lap joints; in the case of vertical lap joints, the welding shall be performed from bottom to top (rising).
3. Lift-off electrode.

FIG. 4 LAP JOINT

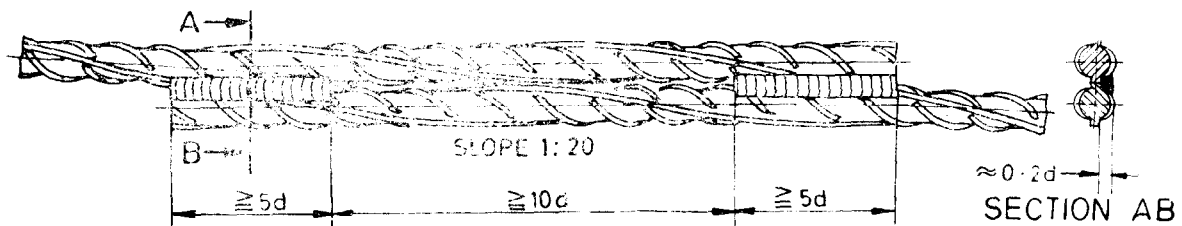
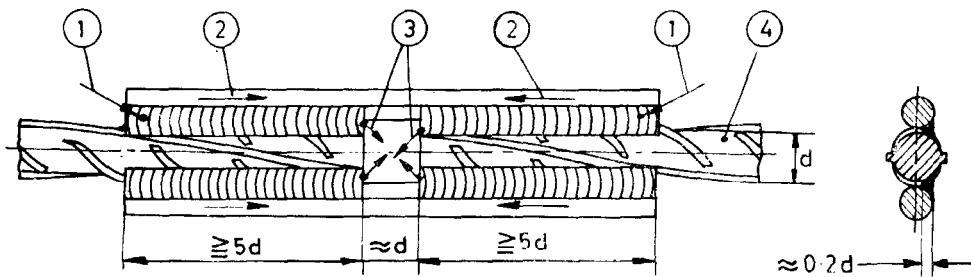

FIG. 5 LAP JOINT (VARIANT)



1. Strike the electrode here; the arc striking point must lie in the groove which will be subsequently welded-over.
2. Welding directions for horizontal or near-horizontal strapped joints; in the case of vertical strapped joints, the welding shall be performed from bottom to top (rising).
3. Lift-off electrode.
4. Butted bar.

FIG. 6 STRAPPED JOINT (d =NOMINAL DIAMETER OF BUTTED BAR)

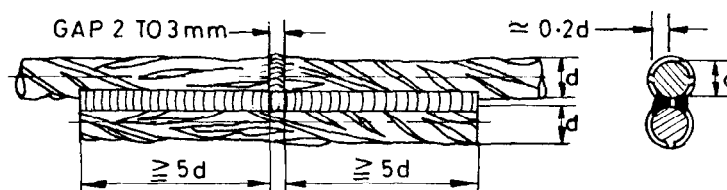

FIG. 7 STRAPPED JOINT (VARIANT)

11 VISUAL INSPECTION

Each welded joint shall be visually inspected for the following.

11.1 Shape of Profile

The profile of the welds shall be uniform, slightly convex and free from overlap at the toes of the welds.

11.2 Uniformity of Surface

The weld surface shall be uniform in appearance throughout its length and shall show no pronounced hump or crater.

11.3 Degree of Undercut

The welded joint shall be free from undercut but slight intermittent occurrences may be disregarded.

11.4 Freedom from Surface Defects

The surface of the weld shall be free from cracks, cavities, solid inclusions and other visible defects.

11.5 Misalignment

The misalignment of the bars welded shall not exceed one-fourth of bar diameter or 5 mm whichever is less.

NOTE — Misalignment shall be evaluated on the basis of smaller diameter in case of bars of unequal diameters are used.

12 INITIAL TESTS

12.1 Prior to production welding, test welds shall be carried out under the local production

conditions to establish that the proposed joints can be made satisfactorily. For the purpose, the tests shall be the same as for 'Quality Control Tests' in 13 but only 3 test pieces will be required for tensile test and 3 for bend test. Such initial tests shall be repeated if there is any change in:

- a) the welding process;
- b) the grade of cold-worked steel bars;
- c) the type or size of electrode;
- d) the welder; and
- e) the position of welding, unless the new position is an easier one.

13 QUALITY CONTROL TESTS

13.1 Butt Welds

Test pieces containing butt welds at the centre in the as-welded condition shall be selected at the rate of one for tensile test and one for bend test for every 100 joints or as decided by the engineer-in-charge.

13.1.1 Tensile Test

Unmachined specimens with a free length between grips about $20d$ should be used. The selected pieces when subjected to a tensile test shall have tensile strength not less than 90 per cent of the actual tensile strength of the bar but in no case less than 485 MPa for grade Fe 415 and 545 MPa for grade Fe 500 of IS 1786 : 1985. The fracture shall not take place in the weld joint.

13.1.2 Bend Test

The welding flash or reinforcement shall be removed at the point where contact is made with the mandrel. The welded joint shall be capable of being bent to an angle of 60° around a mandrel of diameter specified below, before any crack appears:

<i>Nominal Diameter of Bar, d</i>	<i>Diameter of Mandrel</i>
mm	mm
Up to 10	5 <i>d</i>
Over 10	7 <i>d</i>

13.2 Lap Joints

Test pieces containing lap joints at their centre in the as-welded condition shall be selected at the rate of one sample for tensile test for every 100

joints or as decided by the engineer-in-charge.

13.2.1 Tensile Test

The free specimen length between grips must be between 25 *d* and 30 *d* where *d* is the nominal diameter of the bar. The breaking load shall not be less than the guaranteed load in accordance with IS 1786 : 1985 required to fracture the bar.

14 RETESTS

14.1 If a sample selected for testing fails to meet the requirements given under 13.1 and 13.2, the purchaser or his representative shall take two further samples from the same lot. If on testing, either of the samples fails to meet the specified requirements, the whole lot shall be rejected.

ANNEX A

(Clause 2.1)

LIST OF REFERRED INDIAN STANDARDS

<i>IS No.</i>	<i>Title</i>	<i>IS No.</i>	<i>Title</i>
SP 46 : 1988	Engineering drawing practice for schools and colleges	IS 1786 : 1985	Specification for high strength deformed steel bars and wires for concrete reinforcements (<i>third revision</i>)
IS 812 : 1957	Glossary of terms relating to welding and cutting of metals	IS 1851 : 1975	Specification for single operator type arc welding transformers (<i>second revision</i>)
IS 813 : 1986	Scheme of symbols for welding (<i>first revision</i>)	IS 2635 : 1975	Specification for DC electric welding generators (<i>second revision</i>)
IS 814 (Part 1) : 1974	Specification for covered electrodes for metal arc welding of structural steels : Part 1 For welding products other than sheets (<i>fourth revision</i>)	IS 2641 : 1964	Specification for electric welding accessories
IS 815 : 1974	Classification and coding of covered electrodes for metal arc welding of structural steels (<i>second revision</i>)	IS 2751 : 1979	Code of practice for welding of mild steel plain and deformed bars for reinforced concrete construction (<i>first revision</i>)
IS 818 : 1968	Code of practice for safety and health requirements in electric and gas welding and cutting operations (<i>first revision</i>)	IS 3016 : 1982	Code of practice for fire precautions in welding and cutting operations
IS 1179 : 1967	Specification for equipment for eye and face protection during welding (<i>first revision</i>)	IS 9595 : 1980	Recommendations for metal arc welding of carbon and carbon manganese steels
		IS 9857 : 1981	Specification for welding cables

ANNEX B (Clause 6.1)

SELECTION OF EQUIPMENT AND ACCESSORIES FOR WELDING COLD-WORKED BARS USED FOR REINFORCED CONCRETE CONSTRUCTION

B-1 GENERAL

B-1.1 The methods of welding covered in this annex are:

- a) Flash butt welding, and
- b) Shielded metal arc welding with covered electrodes.

B-2 FLASH BUTT WELDING EQUIPMENT

B-2.1 The efficiency of the flash butt welding equipment, manifested by its conjunctive efficiency for cold-worked steels should be about 8 kVA/cm² of the cross sectional area of the bar in order that sufficient cold weld may be accomplished.

B-2.2 The jaws for clamping the bars should preferably be long and pin shaped in order to assume a rectilinear central feeding of the bar ends. The joint should preferably be of copper to assume a smooth and uniform flow of current from the jaws into the bar.

B-3 SHIELDED METAL ARC WELDING EQUIPMENT

B-3.1 In its simplest form, the equipment required for shielded metal arc welding of cold-worked steel bars for concrete reinforcing consists of:

- a) Welding power source;
- b) Accessories, such as, electrode holders, earth clamp, welding cable, connectors, chipping hammer and wire brush;
- c) Protective equipment for the operator, such as, hand screen or helmet, gloves, apron, etc; and
- d) Suitable electrode storage and drying equipment, where necessary.

B-3.1.1 Welding Power Source

The current for welding may be alternating or direct. There is little to choose between them for work involving mild steel welding. Electricity from the mains is usually at too high a voltage for arc welding. Various types of equipment are used for reducing this voltage and delivering a welding current of right characteristics.

B-3.1.1.1 Alternating current transformer of oil-cooled or air-cooled type has the advantage of being low in initial cost and requiring very little maintenance. Various types of controls for varying the current to suit conditions are in common use. Some of these are: (a) a static choke with tapplings, (b) a choke the value of which may be varied by means of the movement of the core, (c) a choke with a saturable

core, and (d) a variable flux linkage transformer. Being essentially a single-phase load, welding transformers when connected to 3-phase supply mains may cause slightly unbalanced load conditions. Condensers of adequate rating may also be connected across the input lines for improving the power factor.

B-3.1.1.2 Rotary machines, such as, motor generators suitable for use on alternating-current mains give a direct current output of the required characteristics. They have the advantage that they impose a balanced load on 3-phase supply mains. They are, however, initially more expensive and require more maintenance than transformers.

B-3.1.2 Where the mains supply is direct current, a motor generator designed for direct current mains use has to be selected.

B-3.1.3 Rectifier welding sets which are relatively high in initial cost, require very little maintenance because of elimination of most moving parts. They also impose a balanced load on 3-phase supply mains.

B-3.1.4 For work at sites where mains power supply is not available, a petrol or diesel engine driven welding generator may be selected. Such machines are often mounted on trailers for easy portability.

B-3.1.5 Other points to be considered when selecting the equipment are:

- a) that the machine is designed to work satisfactorily in the climatic conditions that will be met with during service;
- b) that it is well made and conforms to relevant Indian Standards, wherever these exist; and
- c) that the current capacity is adequate for welding with the sizes of electrodes expected to be used.

B-3.1.5.1 IS 1851 : 1975 covers transformer welding equipment and IS 2635 : 1975 covers motor generator equipment for manual metal arc welding.

B-3.1.5.2 Electrode holders shall conform to the requirements laid down in IS 2641 : 1964 and shall be of suitable rating for welding with electrodes in sizes expected to be used.

B-3.1.5.3 Welding cables shall conform to the requirements laid down in IS 9857 : 1981, if cables with copper conductors are used. Cables with aluminium conductors shall be of a quality proved for performance. Two lengths of cables are required, one from the welding set to the electrode holder and the other from the work piece to the welding set.

B-3.1.5.4 All cable terminal connections, such as, sockets-earth clamp, shall also conform to the requirements specified in IS 2641 : 1964.

B-3.1.5.5 A well made chipping hammer with a hardened and tough cutting edge and a narrow type wire brush which may reach the root of the weld would also be required for deslagging and cleaning the weld.

B-3.1.6 Protective Equipment

A non-conducting hand screen or helmet fitted with protective filter lens will be required to protect the face and eyes of the operator from the ultra-violet and infra-red rays emitted by the arc. The filter lens has the double function of securing good vision of the arc and giving effective protection by cutting off the harmful rays. The eye and face protection equipment should conform to the appropriate stipulations laid down in IS 1179 : 1967.

B-3.1.6.1 Aprons and leather gloves should be of a standard that has been proved adequate for welder's use. Shoulder guards, leggings and other such protective garments may be necessary when the operator has to do positional welding in conditions where freedom of movement is restricted.

B-3.1.7 Storage

The conditions of the electrodes used have an important bearing on the ultimate quality of the weld produced. Particularly, when moist ambient conditions are envisaged, for instance, at site work, the storage of electrodes has to be given much attention. Heated storage cabinets or drying ovens are a must when low hydrogen type electrodes are being used for site work. Other types of electrodes also are preferably stored before use in such cabinets when ambient conditions are unfavourable.

ANNEX C

(Clause 10.4.2)

GAS PRESSURE WELDING

C-1 GAS PRESSURE WELDING PROCESS

The gas pressure welding process may be used for butt welding of reinforcing bars.

C-1.1 Preparation for Welding

C-1.1.1 The ends of bars and the extreme untwisted ends of new bars shall be cut by shearing or machining to make the face approximately normal to the axis of the bar. Care should be taken to ensure that the bar ends do not twist while shearing.

C-1.1.2 Rust, oil, paint, cement paste and any other coating over the bar-ends shall be removed and the surfaces to be welded shall be finished as flat as possible.

C-1.2 Procedure

C-1.2.1 Bars are clamped securely in the clamping unit with no misalignment keeping the gap between the bar ends less than 3 mm.

C-1.2.2 To begin with, the bar ends are heated by a reducing flame to avoid any oxide formation. The flame shall be directed at the joint and the burner shall be rotated to ensure uniform heating of the bar ends. On sufficient heating, the gap between the bar ends shall be closed by the application of axial pressure (preliminary or first stage pressurization).

C-1.2.3 After preliminary pressurization and complete closing of the gap, the bar ends shall be heated by a neutral flame. The heating shall be done for an appropriate period ensuring that the bar ends do not melt.

C-1.2.4 On sufficient heating of the bar ends, appropriate axial pressure (final or second stage pressurization) is applied so that the bulge at the weld interface is about 1.4 times

the bar diameter. Heating shall be stopped at this stage. However, pressure application shall be maintained for some time even after the flame is put off.

C-1.2.5 The bars shall be unclamped after the glow of the heated area vanishes.

C-1.2.6 In case the flame dies out during heating, the affected area shall be cut off and the welding procedure begun afresh.

C-2 GAS PRESSURE WELDING EQUIPMENT

C-2.1 The equipment for gas pressure welding comprises of:

- a) Oxygen and acetylene gas cylinders with regulating valves, etc;
- b) Multi-nozzle burner;
- c) Clamping unit; and
- d) Pressurizer.

C-2.1.1 The burner consists of a blow pipe with four or more nozzles. The nozzles shall be so arranged to ensure uniform heating of the bar surface. The burner shall provide stable flame during heating and the heating capacity shall be appropriate to the size of the bar.

C-2.1.2 The clamping unit shall grip the bars well, be easy to handle, capable of being used in horizontal or vertical position of welding, and have such mechanism that no misalignment develops at the welded portion.

C-2.1.3 Pressurizer shall be either hydraulic or mechanical and may be either manually operated or electrically driven. The pressurizer shall be capable of maintaining uniform axial pressure.

Standard Mark

The use of the Standard Mark is governed by the provisions of the *Bureau of the Indian Standards, Act, 1986* and the Rules and Regulations made thereunder. The Standard Mark on products covered by an Indian Standard conveys the assurance that they have been produced to comply with the requirements of that standard under a well defined system of inspection, testing and quality control which is devised and supervised by BIS and operated by the producer. Standard marked products are also continuously checked by BIS for conformity to that standard as a further safeguard. Details of conditions under which a licence for the use of the Standard Mark may be granted to manufacturers or producers may be obtained from the Bureau of Indian Standards.

Bureau of Indian Standards

BIS is a statutory institution established under the *Bureau of Indian Standards Act, 1986* to promote harmonious development of the activities of standardization, marking and quality certification of goods and attending to connected matters in the country.

Copyright

BIS has the copyright of all its publications. No part of these publications may be reproduced in any form without the prior permission in writing of BIS. This does not preclude the free use, in the course of implementing the standard, of necessary details, such as symbols and sizes, type or grade designations. Enquiries relating to copyright be addressed to the Director (Publications), BIS.

Revision of Indian Standards

Indian Standards are reviewed periodically and revised, when necessary and amendments, if any, are issued from time to time. Users of Indian Standards should ascertain that they are in possession of the latest amendments or edition. Comments on this Indian Standard may be sent to BIS giving the following reference :

Doc : No. SMDC 15 (2919)

Amendments Issued Since Publication

Amend No.	Date of Issue	Text Affected

BUREAU OF INDIAN STANDARDS

Headquarters :

Manak Bhavan, 9 Bahadur Shah Zafar Marg, New Delhi 110002
Telephones : 331 01 31, 331 13 75

Telegrams : Manaksanstha
(Common to all Offices)

Regional Offices :

Central : Manak Bhavan, 9 Bahadur Shah Zafar Marg
NEW DELHI 110002

Telephone
{ 331 01 31
{ 331 13 75

Eastern : 1/14 C.I.T. Scheme VII M, V.I.P. Road, Maniktola
CALCUTTA 700054

36 24 99

Northern : SCO 445-446, Sector 35-C, CHANDIGARH 160036

{ 2 18 43
{ 3 16 41

Southern : C.I.T. Campus, 4 Cross Road. MADRAS 600113

{ 41 24 42
{ 41 25 19
{ 41 29 16

Western : Manakalaya, E9 MIDC, Marol, Andheri (East)
BOMBAY 400093

6 32 92 95

Branches : AHMADABAD. BANGALORE. BHOPAL. BHUBANESWAR.
GUWAHATI. HYDERABAD. JAIPUR. KANPUR. PATNA.
TRIVANDRUM.