

IS : 9399 - 1979
(Reaffirmed 1987)

Indian Standard

SPECIFICATION FOR
APPARATUS FOR FLEXURAL
TESTING OF CONCRETE

(First Reprint NOVEMBER 1991)

UDC 620.174.05:666.972

© Copyright 1980

BUREAU OF INDIAN STANDARDS
MANAK BHAVAN, 9 BAHADUR SHAH ZAFAR MARG
NEW DELHI 110002

Indian Standard

SPECIFICATION FOR APPARATUS FOR FLEXURAL TESTING OF CONCRETE

Cement and Concrete Sectional Committee, BDC 2

Chairman

DR H. C. VISVESVARAYA

Representing

Cement Research Institute of India, New Delhi

Members

ADDITIONAL DIRECTOR, STANDARDS (B&S)	Research, Designs & Standards Organization (Ministry of Railways)
DEPUTY DIRECTOR, STANDARDS (B&S) (<i>Alternate</i>)	
SHRI K. C. AGGARWAL	Hindustan Prefab Ltd, New Delhi
SHRI C. L. KASLIWAL (<i>Alternate</i>)	
SHRI K. P. BANERJEE	Larsen & Toubro Ltd, Bombay
SHRI HARISH N. MALANI (<i>Alternate</i>)	
SHRI S. K. BANERJEE	National Test House, Calcutta
SHRI R. N. BANSAL	Beas Designs Organization, Nangal Township
SHRI T. C. GARG (<i>Alternate</i>)	
CHIEF ENGINEER (DESIGNS)	Central Public Works Department, New Delhi
EXECUTIVE ENGINEER (DESIGNS) III (<i>Alternate</i>)	
CHIEF ENGINEER (PROJECTS)	Irrigation Department, Government of Punjab
DIRECTOR, IPRI (<i>Alternate</i>)	
DIRECTOR (CSMRS)	Central Water Commission, New Delhi
DEPUTY DIRECTOR (CSMRS) (<i>Alternate</i>)	
DR R. K. GHOSH	Central Road Research Institute (CSIR), New Delhi
SHRI Y. R. PHULL (<i>Alternate I</i>)	
SHRI M. DINAKARAN (<i>Alternate II</i>)	
DR R. K. GHOSH	Indian Roads Congress, New Delhi
SHRI B. R. GOVIND	Engineer-in-Chief's Branch, Army Headquarters
SHRI P. C. JAIN (<i>Alternate</i>)	
SHRI A. K. GUPTA	Hyderabad Asbestos Cement Products Ltd, Hyderabad
DR R. R. HATTIANGADI	The Associated Cement Companies Ltd, Bombay
SHRI P. J. JAGUS (<i>Alternate</i>)	
DR IQBAL ALI	Engineering Research Laboratories, Hyderabad
SHRI S. R. KULKARNI	M. N. Dastur & Co (Pvt) Ltd, Calcutta

(Continued on page 2)

© Copyright 1980

BUREAU OF INDIAN STANDARDS

This publication is protected under the *Indian Copyright Act (XIV of 1957)* and reproduction in whole or in part by any means except with written permission of the publisher shall be deemed to be an infringement of copyright under the said Act.

(Continued from page 1)

<i>Members</i>	<i>Representing</i>
SHRI S. K. LAHA SHRI B. T. UNWALLA (<i>Alternate</i>) DR MOHAN RAI	The Institution of Engineers (India), Calcutta Central Building Research Institute (CSIR), Roorkee
DR S. S. REHSI (<i>Alternate</i>) SHRI K. K. NAMBIAR	In personal capacity (<i>Ramanalaya 11 First Crescent Park Road, Gandhinagar, Adyar, Madras</i>) Structural Engineering Research Centre (CSIR), Roorkee
DR M. RAMAIAH DR N. S. BHAL (<i>Alternate</i>) SHRI G. RAMDAS	Directorate General of Supplies & Disposals, New Delhi National Buildings Organization, New Delhi
DR A. V. R. RAO SHRI J. SEN GUPTA (<i>Alternate</i>) SHRI R. V. CHALAPATHI RAO SHRI S. ROY (<i>Alternate</i>)	Geological Survey of India, Calcutta Gammon India Ltd, Bombay
SHRI T. N. S. RAO SHRI S. R. PINHEIRO (<i>Alternate</i>) SHRI ARJUN RUIHSINGHANI SHRI K. VITHAL RAO (<i>Alternate</i>) SECRETARY	Cement Corporation of India Ltd, New Delhi Central Board of Irrigation and Power, New Delhi
DEPUTY SECRETARY (I) (<i>Alternate</i>) SHRI N. SIVAGURU	Roads Wing (Ministry of Shipping and Transport)
SHRI R. L. KAPOOR (<i>Alternate</i>) SHRI K. A. SUBRAMANIAM SHRI P. S. RAMACHANDARAN (<i>Alternate</i>) SUPERINTENDING ENGINEER (DESIGNS) EXECUTIVE ENGINEER (SM&R DIVISION) (<i>Alternate</i>)	The India Cements Ltd, Madras Public Works Department, Government of Tamil Nadu
SHRI L. SWAROOP SHRI A. V. RAMANA (<i>Alternate</i>) SHRI B. T. UNWALLA SHRI Y. K. MEHTA (<i>Alternate</i>) SHRI D. AJITHA SIMHA, Director (Civ Engg)	Dalmia Cement (Bharat) Ltd, New Delhi The Concrete Association of India, Bombay Director General, ISI (<i>Ex-officio Member</i>)

Secretary

SHRI M. N. NEELAKANDHAN
Assistant Director (Civ Engg), ISI

Instruments for Cement and Concrete Testing Subcommittee, BDC 2:10

Convener

DR IQBAL ALI <i>Members</i>	Engineering Research Laboratories, Hyderabad
PROF B. M. AHUJA SHRI T. P. EKAMBARAM	Indian Institute of Technology, New Delhi Highways Research Station, Madras

(Continued on page 8)

Indian Standard

SPECIFICATION FOR APPARATUS FOR FLEXURAL TESTING OF CONCRETE

0. FOREWORD

0.1 This Indian Standard was adopted by the Indian Standards Institution on 20 December 1979, after the draft finalized by the Cement and Concrete Sectional Committee had been approved by the Civil Engineering Division Council.

0.2 The Indian Standards Institution has already published a series of standards on methods of testing cement and concrete. It has been recognized that reproducible and repeatable test results can be obtained only with standard testing equipment capable of giving the desired level of accuracy. The Sectional Committee has, therefore, decided to bring out a series of specifications covering the requirements of equipments used for testing cement and concrete, to encourage their development and manufacture in the country.

0.3 Accordingly, this standard has been prepared to cover the requirements of the flexural testing apparatus used for the determination of modulus of rupture of concrete. The value of modulus of rupture gives a relative measure of the tensile strength of concrete. The method of determining the modulus of rupture has been covered in IS : 516-1959*.

0.4 In the formulation of this standard, due weightage has been given to international co-ordination among the standards and practices prevailing in different countries in addition to relating it to the practices in the field in this country.

0.5 For the purpose of deciding whether a particular requirement of this standard is complied with, the final value, observed or calculated, expressing the result of a test or analysis, shall be rounded off in accordance with IS : 2-1960†. The number of significant places retained in the rounded off value should be the same as that of the specified value in this standard.

*Methods of test for strength of concrete.

†Rules for rounding off numerical values (*revised*).

1. SCOPE

1.1 This standard covers the requirements of flexural testing apparatus used for the determination of modulus of rupture of concrete, that is, $15 \times 15 \times 70$ cm or $10 \times 10 \times 50$ cm beams by third point loading method, making use of any suitable machine for application of load (see 4).

2. REQUIREMENTS OF THE APPARATUS

2.1 The assembly used for the flexural testing apparatus shall satisfy the following requirements:

- a) It shall have two bearing blocks and two load applying blocks for third point loading.
- b) The load shall be equally divided between the two loading blocks.
- c) It shall ensure application of load normal to the loaded and supported surfaces of the specimen and in such a manner as to avoid any eccentricity, restraint or torsion.

2.2 A diagram of a typical flexural testing apparatus that complies with the requirements specified in 2.1 is given in Fig. 1.

3. DIMENSIONS AND SALIENT FEATURES OF THE APPARATUS

3.1 Dimensions — The principal dimensions of different component parts of the flexural testing apparatus shall be as detailed in Fig. 1.

3.2 Salient Features — The salient features of the apparatus shall be as given in 3.2.1 to 3.2.4.

3.2.1 The bearing surfaces shall be of case hardened steel having a hardness of not less than 480 VH or equivalent. The bearing blocks as well as the load applying blocks shall be cylindrical rollers of 40 mm diameter as shown in Fig. 1.

3.2.2 The load applying and supporting blocks shall be held in position by means of spring loaded screws or other suitable arrangements which shall not interfere with the requirements specified in 2.1.

3.2.3 The load applying and supporting blocks shall have a length at least 10 mm greater than the width of the beam. The frames on which the loading as well as the bearing blocks are to be supported, shall have suitable provisions for mounting blocks at two different positions depending on the size of the beam to be tested, that is, on the bottom frame at 60 cm span for 15×15 cm specimens and 40 cm span for 10×10 cm specimens, and on the top frame at 20 cm and 13.3 cm respectively.

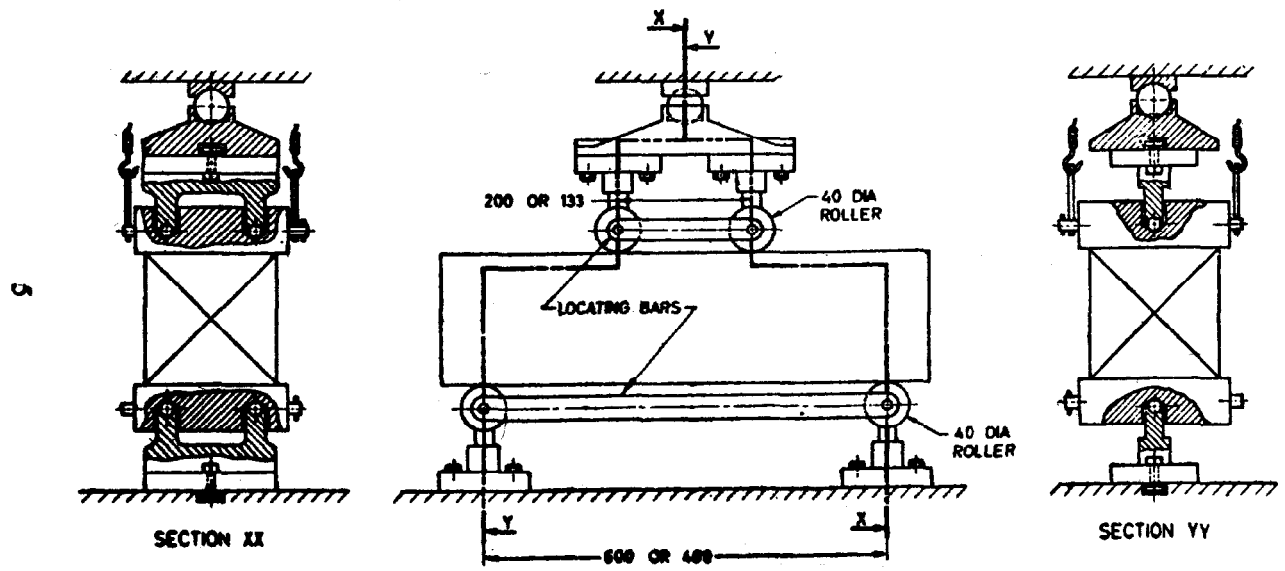

NOTE — Locating bars shall be removed before loading is commenced.
 All dimensions in millimitres.

FIG. 1 TYPICAL ARRANGEMENT OF FLEXURAL TESTING APPARATUS WITH A BEAM CENTRED FOR LOADING

3.2.4 Loading System — The load shall be applied through the two loading blocks mounted on the top supporting frame at a centre to centre distance of 20 cm or 13.3 cm and resting symmetrically on the specimen as shown in Fig. 1.

4. REQUIREMENTS OF THE MACHINE USED FOR LOAD APPLICATION

4.1 Capacity — The capacity of the machine used for application of load shall be not more than 50 kN and it shall be capable of applying the load at the required rate. In case the capacity of the machine is more, it may still be used provided it has 50 kN range also and satisfies the requirements specified in 4.2 to 4.5.

4.2 Accuracy — The percentage of error for loads within the loading range of the testing machine shall not exceed ± 1 percent of the applied load between one-fifth and full load range and ± 0.2 percent of the maximum load below one-fifth of the full load range where high accuracy is required. In other cases, the error shall not be more than 1.5 percent.

4.2.1 The loading range used for calibrating the machine shall not include the loads below the value equal to 100 times the smallest change of load which can be estimated on the load indicating scale of the testing machine.

4.3 Rate of Loading — The testing machine shall be equipped such that the load may be applied without shock and increased continuously at a rate of approximately 4 kN/min for 15×15 cm specimens and at a rate of 1.8 kN/min for 10×10 cm specimens.

4.4 A certificate of calibration shall be furnished along with the machine.

4.5 It is recommended that testing machines in constant use shall be calibrated every 12 months and when intermittently used, every 2 years.

5. MARKING

5.1 The following information shall be clearly and indelibly marked on the apparatus or on each component if possible, in a way that it does not interfere with the performance of the apparatus.

- a) Name of manufacturer or his registered trade-mark or both, and
- b) Date of manufacture.

5.1.1 The apparatus may also be marked with the ISI Certification Mark.

NOTE — The use of the ISI Certification Mark is governed by the provisions of the Indian Standards Institution (Certification Marks) Act and the Rules and Regulations made thereunder. The ISI Mark on products covered by an Indian Standard conveys the assurance that they have been produced to comply with the requirements of that standard under a well-defined system of inspection, testing and quality control which is devised and supervised by ISI and operated by the producer. ISI marked products are also continuously checked by ISI for conformity to that standard as a further safeguard. Details of conditions under which a licence for the use of the ISI Certification Mark may be granted to manufacturers or processors, may be obtained from the Indian Standards Institution.

IS : 9399 - 1979

(Continued from page 2)

Members

DR R. K. GHOSH

SHRI K. L. SETHI (*Alternate*)

SHRI H. K. GUHA

SHRI V. K. VASUDEVAN (*Alternate*)

SHRI P. J. JAGUS

SHRI D. A. WADIA (*Alternate*)

SHRI M. R. JOSHI

SHRI Y. P. PATHAK (*Alternate*)

SHRI E. K. RAMACHANDRAN

PROF C. K. RAMESH

DR R. S. AYYAR (*Alternate*)

SHRI M. V. RANGA RAO

DR K. C. NARANG (*Alternate*)

DR S. S. REHSI

SHRI J. P. KAUSHISH (*Alternate*)

SHRI M. M. D. SETH

SHRI J. P. BHATNAGAR (*Alternate*)

SHRI H. C. VERMA

SHRI A. V. SHASTRI (*Alternate*)

Representing

Central Road Research Institute (CSIR), New Delhi

All India Instruments Manufacturers and Dealers Association, Bombay

The Associated Cement Companies Ltd, Bombay

Research & Development Organization (Ministry of Defence), Pune

National Test House, Calcutta

Indian Institute of Technology, Bombay

Cement Research Institute of India, New Delhi

Central Building Research Institute (CSIR), Roorkee

Public Works Department, Government of Uttar Pradesh

Associated Instrument Manufacturers (India) Private Ltd, New Delhi

BUREAU OF INDIAN STANDARDS

Headquarters:

Manak Bhavan, 9 Bahadur Shah Zafar Marg, NEW DELHI 110002

Telephones: 331 01 31, 331 13 75

Telegrams: Manaksanstha
(Common to all Offices)

Regional Offices:

Telephone

Central : Manak Bhavan, 9 Bahadur Shah Zafar Marg, NEW DELHI 110002	{ 331 01 31 331 13 75
*Eastern : 1/14 C. I. T. Scheme VII M, V. I. P. Road, Maniktola, CALCUTTA 700054	{ 36 24 99
Northern : SCO 445-446, Sector 35-C, CHANDIGARH 160036	{ 2 18 43 3 16 41 41 24 42
Southern : C. I. T. Campus, MADRAS 600113	{ 41 25 19 41 29 16
†Western : Manakalaya, E9 MIDC, Marol, Andheri (East), BOMBAY 400093	{ 6 32 92 95

Branch Offices:

'Pushpak', Nurmohamed Shaikh Marg, Khanpur, AHMADABAD 380001	{ 2 63 48 2 63 49
‡Peenya Industrial Area 1st Stage, Bangalore Tumkur Road BANGALORE 560058	{ 38 49 55 38 49 56
Gangotri Complex, 5th Floor, Bhadbhada Road, T. T. Nagar, BHOPAL 462003	{ 6 67 16
Plot No. 82/83, Lewis Road, BHUBANESHWAR 751002	{ 5 36 27
53/5, Ward No. 29, R.G. Barua Road, 5th Byelane, GUWAHATI 781003	{ 3 31 77
6-8-56C L. N. Gupta Marg (Nampally Station Road), HYDERABAD 500001	{ 23 10 83
R14 Yudhister Marg, C Scheme, JAIPUR 302005	{ 6 34 71 6 98 32
117/418 B Sarvodaya Nagar, KANPUR 208005	{ 21 68 76 21 82 92
Patliputra Industrial Estate, PATNA 800013	{ 6 23 05
T.C. No. 14/1421, University P.O., Palayam TRIVANDRUM 695035	{ 6 21 04 6 21 17

Inspection Offices (With Sale Point):-

Pushpanjali, First Floor, 205-A West High Court Road, Shankar Nagar Square, NAGPUR 440010	{ 2 51 71
Institution of Engineers (India) Building, 1332 Shivaji Nagar, PUNE 411005	{ 5 24 35

*Sales Office in Calcutta is at 5 Chowringhee Approach, P. O. Princep 27 68 00
Street, Calcutta 700072

†Sales Office in Bombay is at Novelty Chambers, Grant Road, 89 65 28
Bombay 400007

‡Sales Office in Bangalore is at Unity Building, Narasimharaja Square, 22 36 71
Bangalore 560002

Reprography Unit, BIS, New Delhi, India