

IS : 9375 - 1979

Indian Standard
SPECIFICATION FOR
PRECAST REINFORCED CONCRETE
PLANT GUARDS

UDC 632.935.72 : [666.982.2]

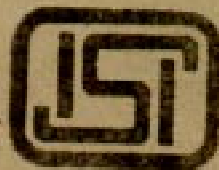

© Copyright 1980

INDIAN STANDARDS INSTITUTION
MANAK BHAVAN, 9 BAHADUR SHAH ZAFAR MARG
NEW DELHI 110002

Price Rs 6.00

Gr 3

April 1980

Indian Standard

SPECIFICATION FOR PRECAST REINFORCED CONCRETE PLANT GUARDS

Cement and Concrete Sectional Committee, BDC 2

Chairman

DR H. C. VISVESVARAYA

Representing

Cement Research Institute of India, New Delhi

Members

ADDITIONAL DIRECTOR, STANDARDS (B & S)	Research, Designs & Standards Organization (Ministry of Railways)
DEPUTY DIRECTOR, STANDARDS (B & S) (<i>Alternate</i>)	
SHRI K. C. AGGARWAL	Hindustan Prefab Ltd, New Delhi
SHRI C. L. KASLIWAL (<i>Alternate</i>)	
SHRI S. K. BANERJEE	National Test House, Calcutta
SHRI K. P. BANERJEE	Larsen & Toubro Ltd, Bombay
SHRI HARISH N. MALANI (<i>Alternate</i>)	
SHRI R. N. BANSAL	Beas Designs Organization, Nangal Township
SHRI T. C. GARG (<i>Alternate</i>)	
CHIEF ENGINEER (DESIGNS EXECUTIVE ENGINEER (DESIGNS) III (<i>Alternate</i>)	Central Public Works Department, New Delhi
CHIEF ENGINEER (PROJECTS)	Irrigation Department, Government of Punjab, Chandigarh
DIRECTOR, IPRI (<i>Alternate</i>)	
DIRECTOR (CSMRS)	Central Water Commission, New Delhi
DEPUTY DIRECTOR (CSMRS) (<i>Alternate</i>)	
DR R. K. GHOSH	Central Road Research Institute (CSIR), New Delhi
SHRI Y. R. PHULL (<i>Alternate I</i>)	
SHRI M. DINAKARAN (<i>Alternate II</i>)	
DR R. K. GHOSH	Indian Roads Congress, New Delhi

(Continued on page 2)

© Copyright 1980

INDIAN STANDARDS INSTITUTION

This publication is protected under the *Indian Copyright Act* (XIV of 1957) and reproduction in whole or in part by any means except with written permission of the publisher shall be deemed to be an infringement of copyright under the said Act.

(Continued from page 1)

<i>Members</i>	<i>Representing</i>
SHRI B. R. GOVIND	Engineer-in-Chief's Branch, Army Headquarters
SHRI P. C. JAIN (<i>Alternate</i>)	
SHRI A. K. GUPTA	Hyderabad Asbestos Cement Products Ltd, Hyderabad
DR R. R. HATTIANGADI	The Associated Cement Companies Ltd, Bombay
SHRI P. J. JAGUS (<i>Alternate</i>)	
DR IQBAL ALI	Engineering Research Laboratories, Hyderabad
SHRI M. T. KANSE	Directorate General of Supplies & Disposals, New Delhi
SHRI S. R. KULKARNI	M. N. Dastur & Co (Pvt) Ltd, Calcutta
SHRI S. K. LAHA	The Institution of Engineers (India), Calcutta
SHRI B. T. UNWALLA (<i>Alternate</i>)	
DR MOHAN RAI	Central Building Research Institute (CSIR), Roorkee
DR S. S. REHSI (<i>Alternate</i>)	
SHRI K. K. NAMBIAR	In personal capacity ('Ramanalaya' II First Crescent Park Road, Gandhinagar, Adyar, Madras)
DR M. RAMAIAH	Structural Engineering Research Centre (CSIR), Roorkee
DR N. S. BHAL (<i>Alternate</i>)	
DR A. V. R. RAO	National Buildings Organization, New Delhi
SHRI J. SEN GUPTA (<i>Alternate</i>)	
SHRI R. V. CHALAPATHI RAO	Geological Survey of India, Calcutta
SHRI S. ROY (<i>Alternate</i>)	
SHRI T. N. S. RAO	Gammon India Ltd, Bombay
SHRI S. R. PINHEIRO (<i>Alternate</i>)	
SHRI ARJUN RIJHSINGHANI	Cement Corporation of India Ltd, New Delhi
SHRI K. VITHAL RAO (<i>Alternate</i>)	
SECRETARY	Central Board of Irrigation and Power, New Delhi
DEPUTY SECRETARY (I) (<i>Alternate</i>)	
SHRI N. SIVAGURU	Roads Wing, Ministry of Shipping and Transport
SHRI R. L. KAPOOR (<i>Alternate</i>)	
SHRI K. A. SUBRAMANIAM	The India Cements Ltd, Madras
SHRI P. S. RAMACHANDRAN (<i>Alternate</i>)	
SUPERINTENDING ENGINEER	Public Works Department, Government of Tamil (DESIGNS) Nadu, Madras
EXECUTIVE ENGINEER	
(SM & R DIVISION) (<i>Alternate</i>)	
SHRI L. SWAROOP	Dalmia Cement (Bharat) Ltd, New Delhi
SHRI A. V. RAMANA (<i>Alternate</i>)	
SHRI B. T. UNWALLA	The Concrete Association of India, Bombay
SHRI Y. K. MEHTA (<i>Alternate</i>)	
SHRI D. AJITHA SIMHA, Director (Civ Engg)	Director General, ISI (<i>Ex-officio Member</i>)

Secretary

SHRI M. N. NEELAKANDHAM
Assistant Director (Civ Engg), ISI

(Continued on page 12)

Indian Standard

SPECIFICATION FOR PRECAST REINFORCED CONCRETE PLANT GUARDS

0. FOREWORD

0.1 This Indian Standard was adopted by the Indian Standards Institution on 25 November 1979, after the draft finalized by the Cement and Concrete Sectional Committee had been approved by the Civil Engineering Division Council.

0.2 Precast reinforced concrete plant guards have a number of advantages; they have relatively a long life, require little or no maintenance and give a neat appearance. The Sectional Committee, therefore, decided to evolve a specification to cover the requirements of precast concrete plant guards.

0.3 This standard is intended to serve as a guide for the manufacture, installation and testing of reinforced concrete plant guards and therefore has been related to the relevant practices followed in the country. This standard, however, covers only fractionalized (multi-pieces) plant guards which may be arranged in triangular or square pattern and does not cover single piece plant guards.

0.4 For the purpose of deciding whether a particular requirement of this standard is complied with, the final value, observed or calculated, expressing the result of a test or analysis, shall be rounded off in accordance with IS : 2-1960*. The number of significant places retained in the rounded off value should be the same as that of the specified value in this standard.

1. SCOPE

1.1 This standard covers the requirements for precast reinforced concrete plant guards.

1.1.1 This standard covers fractionalized (multi-pieces) plant guards only and does not cover single-piece reinforced concrete plant guards.

*Rules for rounding off numerical values (*revised*).

2. MATERIALS

2.1 Cement — The cement shall conform to IS : 269-1976* or IS : 455-1976† or IS : 1489-1976‡ or IS : 8041-1978§.

2.2 Aggregate — The aggregates shall comply with the requirements of IS : 383-1970|| and shall consist of a graded mixture of clean coarse and fine aggregates. The nominal maximum size of coarse aggregate shall not exceed 12.5 mm.

2.2.1 Where specified, a sample of each variety of aggregates shall be submitted to the purchaser for approval.

2.3 Water — The water shall conform to the requirements specified in IS : 456-1978¶.

2.4 Reinforcement — Steel wire, steel wire fabric or steel bars for reinforcement shall conform to IS : 432 (Part I)-1966**, IS : 432 (Part II)-1966††, IS : 1139-1966‡‡, IS : 1566-1967§§ or IS : 1786-1979||| as appropriate.

2.5 Pozzolanas — Fly ash conforming to IS : 3812 (Part I)-1966¶¶ or burnt clay pozzolana conforming to IS : 1344-1968*** may be used as part replacement of unblended cements provided uniform blending is ensured.

3. MANUFACTURE

3.1 Concrete — Each plant guard unit shall be made of concrete proportioned, mixed, placed and compacted to give a dense concrete free from voids. The concrete used in the manufacture of plant guards shall not be of a grade lower than M 20 (see IS : 456-1978¶). The concrete

*Specification for ordinary and low heat Portland cement (*third revision*).

†Specification for Portland slag cement (*third revision*).

‡Specification for Portland pozzolana cement (*second revision*).

§Specification for rapid hardening Portland cement (*first revision*).

||Specification for coarse and fine aggregates from natural sources for concrete (*second revision*).

¶Code of practice for plain and reinforced concrete (*third revision*).

**Specification for mild steel and medium tensile steel bars and hard-drawn steel wire for concrete reinforcement: Part I Mild steel and medium tensile steel bars (*second revision*).

††Specification for mild steel and medium tensile steel bars and hard-drawn steel wire for concrete reinforcement: Part II Hard drawn steel wire (*second revision*).

‡‡Specification for hot rolled mild steel, medium tensile steel and high yield strength steel deformed bars for concrete reinforcement (*revised*).

§§Specification for hard-drawn steel wire fabric for concrete reinforcement (*first revision*).

|||Specification for cold-worked steel high strength deformed bars for concrete reinforcement (*second revision*).

¶¶Specification for fly ash: Part I For use as pozzolana.

***Specification for burnt clay pozzolana (*first revision*).

shall have a water/cement ratio not exceeding 0.40 by mass. The mix proportions shall be determined by the manufacturer and shall produce a dense concrete.

NOTE — It may be noted for general guidance that nominal mix concrete of grade M 20 corresponds approximately to a mix proportion of 1 : 1.5 : 3.

3.2 Assembly of Reinforcement

3.2.1 Preparation — Reinforcement for concrete shall be free from loose mill scales, loose rust, mud, oil, coats of paints or other coatings which may reduce bond.

3.2.2 Positioning — Reinforced plant guards shall be reinforced with a minimum of one 6 mm diameter longitudinal bar along the periphery. The longitudinal reinforcing steel shall be in one piece. No concrete component member shall be provided without a reinforcing steel of at least 5 mm diameter (see Fig. 1).

3.2.3 Anchorage — Adequate hooks or other forms of anchorage shall be provided to the main reinforcement.

3.2.4 Cover — The main reinforcements shall have a minimum cover of 12 mm or twice the diameter of the main reinforcement, whichever is greater. The manufacturer shall ensure that during placing and compaction of the concrete in the moulds, the minimum concrete cover is maintained.

3.3 Mixing, Compaction and Curing — Mixing, compaction and curing of concrete for manufacture of plant guards shall be in accordance with IS : 456-1978*. Steam curing may be adopted if so desired by the manufacturer, provided requirements of pressure or non-pressure steam curing are fulfilled.

NOTE — When reinforced plant guards are manufactured under field conditions, in the absence of a mechanical vibrator, thorough rodding of the concrete with a round-ended 12 mm diameter rod followed by tamping with a suitable device shall be effective in compacting concrete. At the beginning of the rodding operation, the rod shall be pushed through the concrete almost to the bottom of the mould and the strokes shall be well distributed.

3.4 Maturing — From the date of casting, the plant guards shall be matured for the following periods before testing or despatch, including the period of curing, so that they will attain sufficient strength to resist damage to them when first handled:

Portland slag cement	}	28 days
Ordinary Portland cement		
Portland pozzolana cement		
Rapid-hardening Portland cement		14 days

*Code of practice for plain and reinforced concrete (third revision).

3.5 Casting of a few units with trial mixes and subsequent prototype testing for strength will ensure that the final production of plant guard units is likely to be of satisfactory quality.

4. SHAPE AND DIMENSIONS

4.1 The units of the plant guards shall be of uniform thickness throughout their length, with sufficient openings interspaced (*see* Fig. 1). The cross-sectional dimensions and the reinforcement shall be adequate to conform to the strength requirements given in 7.

The individual units shall have suitable keys and grooves or lugs and slots of sufficient dimensions at the ends for connection purposes.

4.2 Tolerance — The tolerance on the overall length of the plant guards shall be ± 15 mm. The tolerance on the cross-sectional dimensions shall be ± 3 mm. The tolerance on the straightness shall be 0.5 percent.

4.3 Minimum Dimensions — The minimum dimensions of reinforced concrete plant guards shall be as follows:

Minimum height above ground level	1 300 mm
Minimum internal effective width of each unit	750 mm
Minimum percentage of the area of vents in the units to afford ventilation, flow of air, etc	30 percent of the external surface area
Maximum width of vent (to prevent animals from inserting their mouth inside)	50 mm

NOTE — There is no limitation for the length of vent.

4.4 The design of plant guards shall be such that horizontal members likely to enable animals like goats, to have a foot hold shall be kept to the minimum.

4.5 Arrangements for fixing barbed wire above the top level of the plant guards may be provided if necessary.

5. FINISH

5.1 Each plant guard unit shall have a dense surface showing no coarse aggregate and shall have no crevices likely to assist in the disintegration of concrete or rusting of reinforcement by the action of natural agencies.

6. ERECTION AND FIXING

6.1 The plant guard units may be assembled to form triangular or square pattern.

6.2 The units shall be erected exactly vertical with their base truly horizontal. They shall be connected at their ends by suitable bolts and nuts, clamps, clips or tied by means of galvanized iron wire suitably and strongly. The knots in the ties, bolts and nuts, and clips and clamps shall be colour-washed to prevent rusting. A typical arrangement of square layout of reinforced concrete plant guard is shown in Fig. 1.

6.3 The bottom of the pieces shall be suitably fixed firmly on the ground so that sufficient resistance to lateral dislocation is offered. It shall be embedded at least 150 mm deep if it is in earth or 50 mm in concrete and metalled road surface.

7. STRENGTH REQUIREMENT

7.1 Static Load Test — When tested in accordance with the method of test described in Appendix A, the load required to produce the first visible crack in the reinforced concrete plant guard shall be not less than 300 kg.

8. SAMPLING AND INSPECTION

8.1 Scale of Sampling

8.1.1 Lot — In any batch, all plant guard units of the same class and same dimensions shall be grouped together to constitute a lot.

8.1.1.1 Sub-lot — If the number of plant guard units in a lot exceeds 500, the lot shall be divided into a suitable number of sub-lots such that the number of units in any sub-lot shall not exceed 500. The acceptance or otherwise of a sub-lot shall be determined on the basis of sample selected from it.

8.1.1.2 The number of plant guard units to be selected from a lot or a sub-lot shall depend upon its size and shall be in accordance with Table 1.

8.1.1.3 The plant guard units shall be selected at random. In order to ensure randomness, all the plant guard units in the lot or the sub-lot may be arranged in a serial order and starting from any random guard unit, every r th unit may be included in the sample, r being the integral part of N/n , where N is the size of the lot or the sub-lot and n the sample size.

8.2 NUMBER OF TESTS

8.2.1 All the plant guard units as selected in accordance with **8.1.1.2** shall be tested for overall length, cross section and uprightness (*see* 4).

8

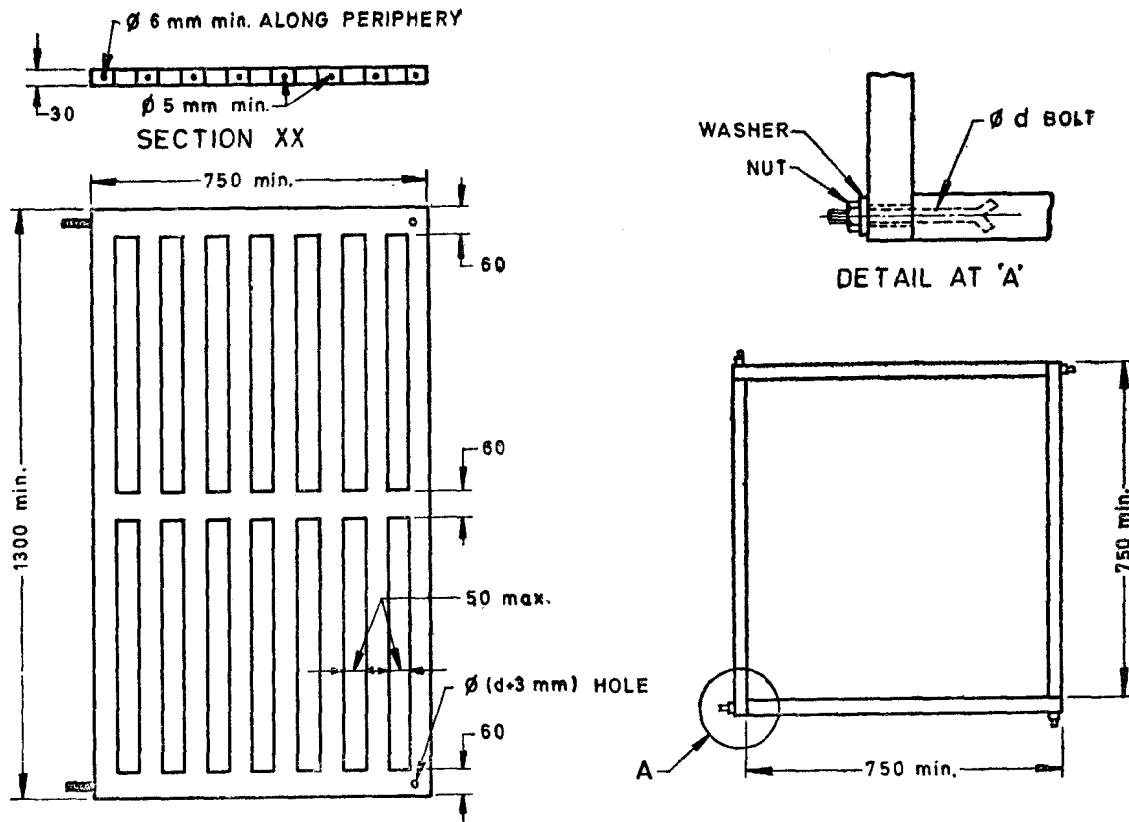

All dimensions in millimetres.

FIG. 1 DETAILS OF A PLANT GUARD UNIT AND A TYPICAL ARRANGEMENT OF PLANT GUARD UNITS IN SQUARE LAYOUT

8.2.2 The number of plant guard units to be tested for strength test (see 7.1) shall be in accordance with Table 1. These plant guards may be selected from those already tested as in 8.2.1.

8.3 CRITERIA FOR CONFORMITY

8.3.1 A lot or a sub-lot shall be considered as conforming to this specification if the conditions under 8.3.2 and 8.3.3 are satisfied.

8.3.2 The plant guard units which do not satisfy the requirements of overall length, cross section and uprightness shall not exceed the appropriate number given in Table 1. If such plant guard units exceed the corresponding numbers, all plant guard units in the lot or sub-lot shall be tested for these requirements and those not satisfying the requirements shall be rejected.

8.3.3 All the plant guard units tested for strength test shall satisfy the requirements of the test. If one or more plant guard units fail, twice the number of plant guard units originally tested shall be selected from those already selected, and subjected to the test. If there is no failure among these plant guard units, the lot or the sub-lot shall be considered to have satisfied the requirements of this test.

TABLE 1 SAMPLE SIZE AND CRITERIA FOR CONFORMITY

(Clauses 8.1.1.2, 8.2.2 and 8.3.2)

SIZE OF LOT OR SUB-LOT	DIMENSIONAL REQUIREMENT		NO. OF PLANT GUARD UNITS FOR STATIC LOAD TEST
	Sample Size	Permissible No. of Defectives	
(1)	(2)	(3)	(4)
Up to 100	10	1	1
101 ,, 200	15	1	2
201 ,, 300	20	2	2
301 ,, 500	30	3	3

9. MARKING

9.1 The plant guard units shall be clearly and indelibly marked with the following particulars either during or after manufacture but before testing, on the external surface in the top at a position so as to be easily read after erection in position:

- a) Year of manufacture, and
- b) Maker's serial number or trade-mark.

9.1.1 Each plant guard unit may also be marked with the ISI Certification Mark.

NOTE — The use of the ISI Certification Mark is governed by the provisions of the Indian Standards Institution (Certification Marks) Act and the Rules and Regulations made thereunder. The ISI Mark on products covered by an Indian Standard conveys the assurance that they have been produced to comply with the requirements of that standard under a well-defined system of inspection, testing and quality control which is devised and supervised by ISI and operated by the producer. ISI marked products are also continuously checked by ISI for conformity to that standard as a further safeguard. Details of conditions under which a licence for the use of the ISI Certification Mark may be granted to manufacturers or processors, may be obtained from the Indian Standards Institution.

A P P E N D I X A

(*Clause 7.1*)

METHOD FOR STATIC LOAD TESTING OF PLANT GUARD UNITS

A-1. The specimen shall be arranged horizontally with its face flat and supported on round bars whose diameter shall be more than 25 mm, as shown in Fig. 2.

A-2. The load shall be applied centrally as shown in Fig. 2 and increased gradually until the first visible crack is observed in the plant guard unit. The applied load then shall be recorded as the test load. Careful observation in good light is necessary to detect the first crack.

A-3. The load at any stage should not be maintained for longer than the time necessary to check for the first visible crack.

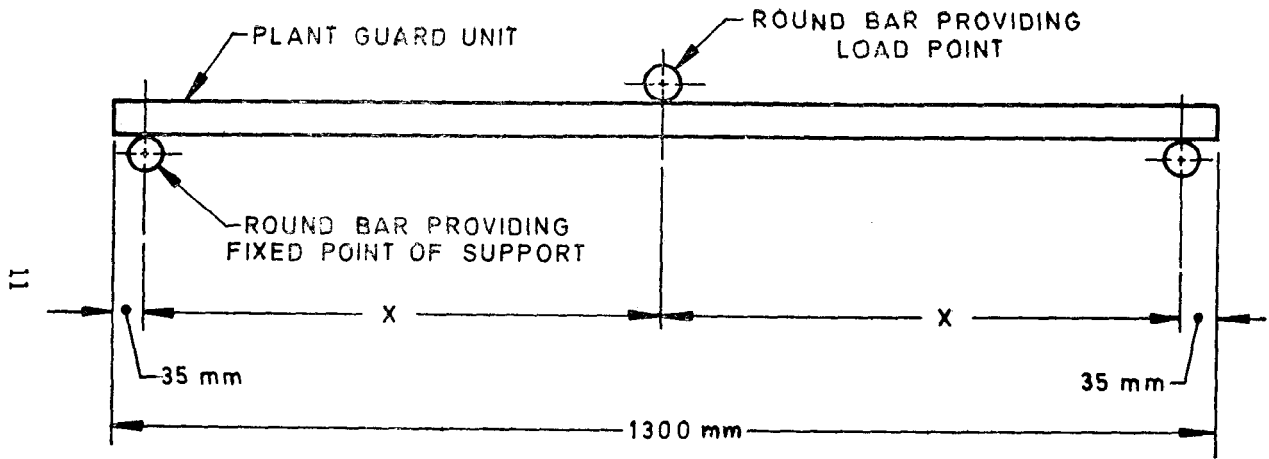

FIG. 2 ARRANGEMENT FOR STATIC LOAD TEST

(Continued from page 2)

Precast Concrete Products Subcommittee, BDC 2 : 9

<i>Members</i>	<i>Representing</i>
DEPUTY DIRECTOR, STANDARDS (B & S)	Research, Designs & Standards Organization, Lucknow
ASSISTANT DIRECTOR, STANDARDS (B & S) II (<i>Alternate</i>)	
DEVELOPMENT MANAGER	Hindustan Prefab Ltd, New Delhi
DIRECTOR (CSMRS)	Central Water Commission, New Delhi
DEPUTY DIRECTOR (CSMRS) (<i>Alternate</i>)	
SHRI V. G. GOKHALE	Bombay Chemicals Pvt Ltd, Bombay
SHRI B. K. JINDAL	Central Building Research Institute (CSIR), Roorkee
DR S. S. REHSI (<i>Alternate</i>)	
SHRI L. C. LAI	In personal capacity (<i>B/17, West End, New Delhi</i>)
DR A. K. MULLICK	Cement Research Institute of India, New Delhi
DR S. C. MAITI (<i>Alternate</i>)	
SHRI S. NAHARROY	Engineering Construction Corporation Ltd, Madras
SHRI A. RAMAKRISHNA (<i>Alternate</i>)	
SHRI D. B. NAIK	Engineer-in-Chief's Branch, Army Headquarters
SHRI SUCHA SINGH (<i>Alternate</i>)	
SHRI K. K. NAMBIAR	In personal capacity (' <i>Ramanalaya</i> ', 11 First Crescent Park Road, Gandhinagar, Adyar, Madras)
SHRI P. S. NATARAJAN	Tamil Nadu Housing Board, Madras
SHRI V. RAMALINGAM	Neyveli Lignite Corporation Ltd, Neyveli
SHRI K. A. RAMABHADRAN (<i>Alternate</i>)	
DR A. V. R. RAO	National Buildings Organization, New Delhi
SHRI J. SEN GUPTA (<i>Alternate</i>)	
SHRI B. G. SHIRKE	B. G. Shirke & Co Pvt Ltd, Pune
SHRI U. S. DURGAKERI (<i>Alternate</i>)	
SHRI C. N. SRINIVASAN	Messrs C. R. Narayana Rao, Madras
SHRI C. N. RAGHAVENDRAN (<i>Alternate</i>)	
SHRI B. T. UNWALLA	Concrete Association of India, Bombay
SHRI E. T. ANTIA (<i>Alternate</i>)	
DR B. VENKATESWARLU	Structural Engineering Research Centre (CSIR), Madras