

Indian Standard

SPECIFICATION FOR
LIQUID LIMIT APPARATUS FOR SOILS

UDC 624.131.365 ; 536.421.2



© Copyright 1980

INDIAN STANDARDS INSTITUTION
MANAK BHAVAN, 9 BAHADUR SHAH ZAFAR MARG
NEW DELHI 110002

Gr 3

May 1980

Indian Standard

SPECIFICATION FOR LIQUID LIMIT APPARATUS FOR SOILS

Soil Engineering and Rock Mechanics Sectional Committee, BDC 23

Chairman

Representing

PROF DINESH MOHAN

Central Building Research Institute (CSIR),
Roorkee

Members

ADDITIONAL DIRECTOR RESEARCH (FE), RDSO	Ministry of Railways
DEPUTY DIRECTOR RESEARCH (FE-I), RDSO (<i>Alternate</i>)	
PROF ALAM SINGH	University of Jodhpur, Jodhpur
LT-COL AVTAR SINGH	Engineer-in-Chief's Branch, Army Headquarters
MAJ V. K. KANITKAR (<i>Alternate</i>)	
DR A. BANERJEE	Cementation Co Ltd, Calcutta
SHRI S. GUPTA (<i>Alternate</i>)	
DR R. K. BHANDARI	Central Building Research Institute (CSIR), Roorkee
CHIEF ENGINEER (D & R)	Irrigation Department, Government of Punjab, Chandigarh
DIRECTOR (IPRI) (<i>Alternate</i>)	
SHRI K. N. DADINA	In personal capacity (P-820 New Alipore, Calcutta 700053)
SHRI A. G. DASTIDAR	In personal capacity (5 Hungerford Street, 12/1 Hungerford Court, Calcutta 700017)
DR G. S. DHILLON	Indian Geotechnical Society, New Delhi
DIRECTOR (CSMRS)	Central Water Commission, New Delhi
DEPUTY DIRECTOR (CSMRS) (<i>Alternate</i>)	
SHRI A. H. DIVANJI	Asia Foundations & Construction (P) Ltd, Bombay
SHRI A. N. JANGLE (<i>Alternate</i>)	
DR GOPAL RANJAN	University of Roorkee, Roorkee; and Institution of Engineers (India)
DR SHASHI K. GULHATI	Indian Institute of Technology, New Delhi
DR G. V. RAO (<i>Alternate</i>)	

(Continued on page 2)

© Copyright 1980

INDIAN STANDARDS INSTITUTION

This publication is protected under the Indian Copyright Act (XIV of 1957) and reproduction in whole or in part by any means except with written permission of the publisher shall be deemed to be an infringement of copyright under the said Act.

(Continued from page 1)

<i>Members</i>	<i>Representing</i>
SHRI O. P. MALHOTRA	Public Works Department, Government of Punjab, Chandigarh
SHRI T. K. NATARAJAN	Central Road Research Institute (CSIR), New Delhi
RESEARCH OFFICER SHRI K. R. SAXENA SECRETARY	Building & Roads Research Laboratory, Chandigarh Engineering Research Laboratories, Hyderabad Central Board of Irrigation & Power, New Delhi
DEPUTY SECRETARY (<i>Alternate</i>) SHRI M. M. D. SETH	Public Works Department, Government of Uttar Pradesh, Lucknow
DR B. L. DHAWAN (<i>Alternate</i>) SHRI M. K. SINGHAL SHRI N. SIVAGURU	Irrigation Research Institute, Roorkee Roads Wing, Ministry of Shipping & Transport
SHRI D. V. SIKKA (<i>Alternate</i>) SHRI K. S. SRINIVASAN	National Buildings Organization, New Delhi
SHRI SUNIL BERRY (<i>Alternate</i>) SUPERINTENDING ENGINEER (P & D) EXECUTIVE ENGINEER I/C (SM & RD) (<i>Alternate</i>)	Public Works Department, Government of Tamil Nadu, Madras
SHRI B. T. UNWALLA SHRI T. M. MENON (<i>Alternate</i>) SHRI H. C. VERMA	Concrete Association of India, Bombay All India Instruments Manufacturers & Dealers Association, Bombay
SHRI V. S. VASUDEVAN (<i>Alternate</i>) SHRI D. AJITHA SIMHA, Director (Civ Engg)	Director General, ISI (<i>Ex-officio Member</i>)

Secretary

SHRI K. M. MATHUR

Deputy Director (Civ Engg), ISI

Soil Testing Instruments and Equipment Subcommittee, BDC 23 : 6

Convener

SHRI H. C. VERMA Associated Instruments Manufacturers (I) Pvt Lt
New Delhi

Members

SHRI M. D. NAIR (*Alternate* to
Shri H. C. Verma)
LT-COL AVTAR SINGH Engineer-in-Chief's Branch, Army Headquarters
SHRI S. K. GUPTA (*Alternate*)
DEPUTY DIRECTOR RESEARCH Ministry of Railways
(SM) (RDSO)
SHRI H. K. GUHA Geologists' Syndicate Pvt Ltd, Calcutta
SHRI A. BHATTACHARYA (*Alternate*)

(Continued on page 10)

Indian Standard
SPECIFICATION FOR
LIQUID LIMIT APPARATUS FOR SOILS

0. FOREWORD

0.1 This Indian Standard was adopted by the Indian Standards Institution on 10 July 1979, after the draft finalized by the Soil Engineering and Rock Mechanics Sectional Committee had been approved by the Civil Engineering Division Council.

0.2 The Indian Standards Institution has already published a series of standards on methods of testing soils. It has been recognized that reliable and intercomparable test results can be obtained only with standard testing equipment capable of giving the desired level of accuracy. The Sectional Committee has, therefore, decided to bring out a series of specifications covering the requirements of equipment used for testing soils to encourage its development and manufacture in the country.

0.3 The equipment covered in this standard is used for determination of liquid limit (mechanical method) covered in IS : 2720 (Part V)-1970*.

0.4 This standard covers the minimum requirements for the apparatus. The apparatus may also be manufactured with a revolution counter to indicate the number of falls of cup automatically and/or a motorized driving arrangement to give approximately 120 rev/min.

0.5 For the purpose of deciding whether a particular requirement of this standard is complied with, the final value, observed or calculated, expressing the result of a test or analysis, shall be rounded off in accordance with IS : 2-1960†. The number of significant places retained in the rounded off value should be the same as that of the specified value in this standard.

*Methods of test for soils: Part V Determination of liquid and plastic limits (*first revision*).

†Rules for rounding off numerical values (*revised*).

1. SCOPE

1.1 This standard covers the requirements of liquid limit device, grooving tool and gauge block used for determination of liquid limit of soils by mechanical method.

2. DIMENSIONS

2.1 The dimensions, with tolerances, of different component parts of the liquid limit apparatus shall be as detailed in Fig. 1 to 3. The dimensions against which tolerances are not specifically mentioned shall be taken as nominal dimensions and the tolerances as given in IS : 2102-1969* shall apply.

3. LIQUID LIMIT DEVICE

3.1 Materials — The materials of construction of different component parts of the liquid limit device shall be as given in Table 1. All parts made of brass shall be chrome-plated.

TABLE 1 MATERIALS FOR DIFFERENT COMPONENT PARTS OF LIQUID LIMIT DEVICE

Sl. No.	PART	MATERIAL	SPECIAL REQUIREMENT	CONFORMING TO
(1)	(2)	(3)	(4)	(5)
i)	Base	Vulcanized rubber	Hardness : 86 to 90 IRHD (<i>see</i> Note 1) Resilience : 30 to 40 percent (<i>see</i> Note 2)	Grade 6, Type B of IS : 5192-1969*
ii)	Base feet			
iii)	Cup	Sheet brass	—	IS : 410-1967†
iv)	Cam housing	Cast brass	—	IS : 292-1961‡
v)	Sliding carriage			

*Specification for vulcanized natural, rubber based compounds (*first revision*).

†Specification for rolled brass plate, sheet, strip and foil (*second revision*).

‡Specification for brass ingots and castings (*revised*).

(*Continued*)

*Allowable deviations for dimensions without specified tolerances (*first revision*).

TABLE 1 MATERIALS FOR DIFFERENT COMPONENT PARTS OF LIQUID LIMIT DEVICE — Contd

Sl. No.	PART	MATERIAL	SPECIAL REQUIREMENT	CONFORMING TO
(1)	(2)	(3)	(4)	(5)
vi)	Cam	Brass	—	IS : 4170-1967*
vii)	Pin			
viii)	Handle			
ix)	Handle knob			

NOTE 1 — The hardness of the material shall be determined in accordance with IS : 3400 (Part II)-1965 'Methods of test for vulcanized rubbers: Part II Hardness'.

NOTE 2 — The resilience of the material shall be determined in accordance with IS : 3400 (Part XI)-1969 'Methods of test for vulcanized rubbers: Part XI Determination of rebound resilience'.

*Specification for brass rods for general engineering purposes.

3.2 Construction

3.2.1 The liquid limit device shall be constructed in accordance with Fig. 1. It shall consist of a base carrying a sliding carriage assembly to which a cup is hinged. The cup shall be suspended in such a way that it may be raised and dropped through a height of 10 mm with the help of a lead screw provided at the back of the sliding carriage. For ease of operation, the handle to rotate the cam shall be provided for right-hand operation. For rubber feet made of the same material shall be fixed to the base. The cup shall have the dimensions as detailed in Fig. 1. The inside of the cup shall be finished smooth. The cup shall have a brass follower block brazed to it for being suspended from the sliding carriage with the help of a brass pin. It shall be suspended from the top bracket with the help of the brass pin in such a way that it falls freely without having much play at its hinge. The sliding carriage shall have two grooves to facilitate adjustment of fall of the cup to 10 mm. The contact face of the cam shall be smoothly curved. The sliding carriage shall be secured to the top of the cam housing with two knurled head screws made of brass. The handle shall be fixed to the cam shaft. The handle knob shall have free rotating movement.

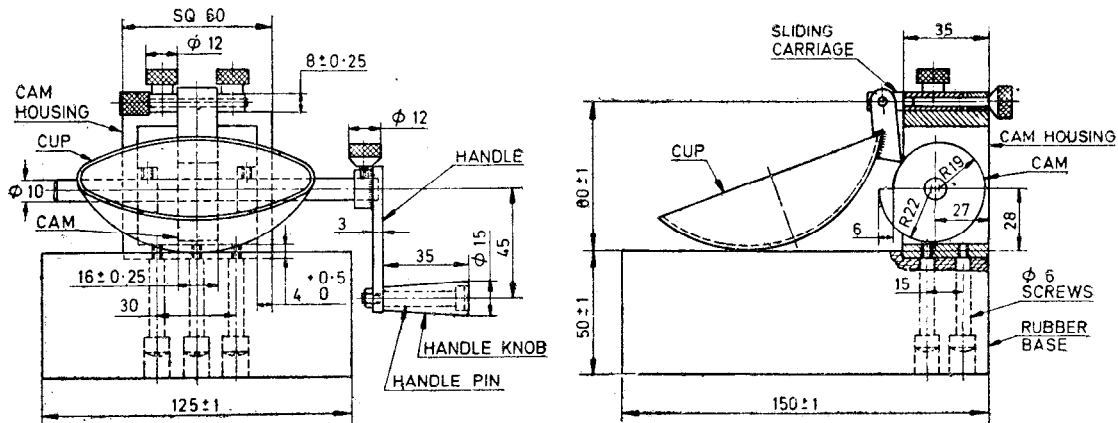

DETAILS OF CUP

All dimensions in millimetres.

FIG. 1 LIQUID LIMIT DEVICE

4. GROOVING TOOLS AND GAUGE BLOCK

4.1 The grooving tools shall be of three types, namely, Type A, Type B, Type C (*see* Fig. 2).

4.2 **Materials** — The materials of construction of the three different types of the grooving tools and of the gauge block shall be as given in Table 2.

TABLE 2 MATERIALS FOR GROOVING TOOLS AND GAUGE BLOCK

SL No.	PART	MATERIAL	SPECIAL REQUIREMENT	CONFORMING TO
(1)	(2)	(3)	(4)	(5)
i)	Grooving tool, Type A	Sheet brass or Cast brass	Smooth finish	IS : 410-1967* or IS : 292-1961†
ii)	Grooving tool, Type B:			
	a) Handle	Brass rod	do	IS : 4170-1967‡
	b) Tool	Cast brass	do	IS : 292-1961†
iii)	Grooving tool, Type C :			
	a) Tool	Sheet brass	do	IS : 410-1967*
	b) Handle	Brass wire	do	IS : 4413-1967§
iv)	Gauge block	Cast brass	do	IS : 292-1961†

*Specification for rolled brass plate, sheet, strip and foil (*second revision*).

†Specification for brass ingots and castings (*revised*).

‡Specification for brass rods for general engineering purposes.

§Specification for brass wires for general engineering purposes.

4.3 Construction

4.3.1 The shapes and dimensions of the grooving tools shall be in accordance with Fig. 2. In the case of Type B grooving tool, the handle is of such a shape and dimensions that it serves for the gauge block.

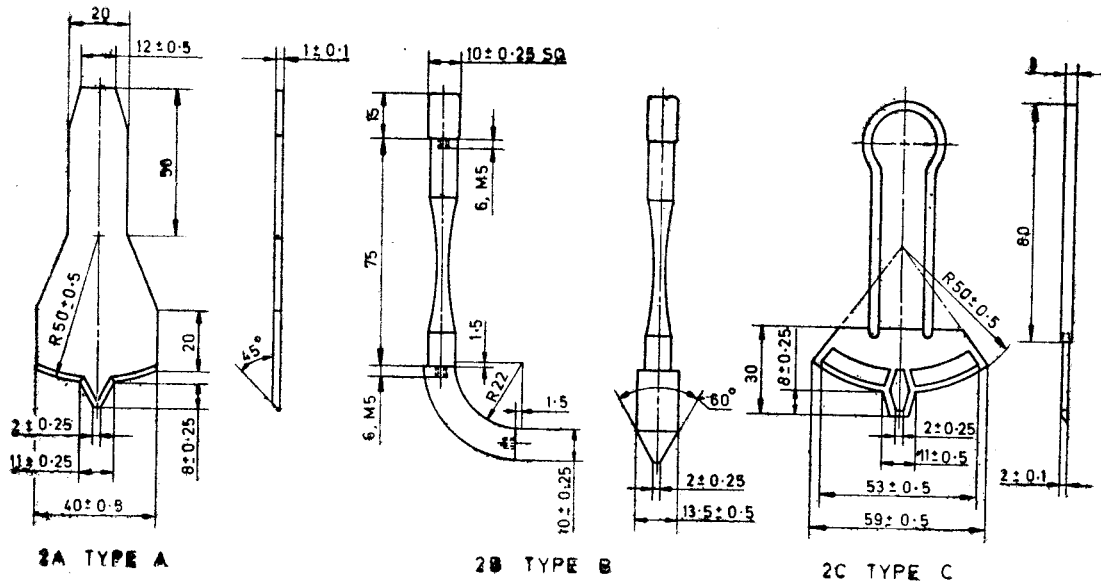

All dimensions in millimetres.

FIG. 2 GROOVING TOOLS

4.3.2 The shape and dimensions of the gauge block shall be in accordance with Fig. 3. The gauge block shall be finished smooth.

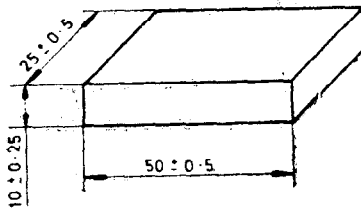

All dimensions in millimetres.

FIG. 3 GAUGE BLOCK

5. MARKING

5.1 The liquid limit device, the grooving tools and the gauge block shall be clearly marked with the following information:

- a) Name of the manufacturer or his registered trade-mark or both,
- b) Date of manufacture, and
- c) Type (where applicable).

5.1.1 The apparatus may also be marked with the ISI Certification Mark.

NOTE — The use of the ISI Certification Mark is governed by the provisions of the Indian Standards Institution (Certification Marks) Act and the Rules and Regulations made thereunder. The ISI Mark on products covered by an Indian Standard conveys the assurance that they have been produced to comply with the requirements of that standard under a well-defined system of inspection, testing and quality control which is devised and supervised by ISI and operated by the producer. ISI marked products are also continuously checked by ISI for conformity to that standard as a further safeguard. Details of conditions under which a licence for the use of the ISI Certification Mark may be granted to manufacturers or processors, may be obtained from the Indian Standards Institution.

(Continued from page 2)

SHRI A. K. GUPTA	Saraswati Engineering Agency, Roorkee
SHRI RAKESH GOEL (<i>Alternate</i>)	
DR B. R. MALHOTRA	Central Road Research Institute (CSIR), New Delhi
SHRI R. S. MELKOTE	Central Water Commission, New Delhi
DEPUTY DIRECTOR (CSMRS)	
(<i>Alternate</i>)	
DR P. NANDAKUMARAN	University of Roorkee, Roorkee
SHRI S. G. PRASAD	Industrial Electronics Pvt Ltd, Bangalore
SHRI H. S. DAHELE (<i>Alternate</i>)	
SHRI D. D. PURI	Central Scientific Instruments Organisation (CSIR), Chandigarh
SHRI A. N. AGARWAL (<i>Alternate</i>)	
DR T. RAMAMURTHY	Indian Institute of Technology, New Delhi
SHRI RESHAM SINGH	Hydraulic & Engineering Instruments Co, New Delhi
SHRI JATINDER SINGH (<i>Alternate</i>)	
DR V. SREENIVARULU	Central Building Research Institute (CSIR), Roorkee

AMENDMENT NO. 1 JANUARY 1981

TO

IS:9259-1979 SPECIFICATION FOR LIQUID LIMIT
APPARATUS FOR SOILS

Corrigendum

(Page 8, Fig. 2A, dimension) - Substitute
'1.6 \pm 0.1' for '1 \pm 0.1'.

(BDC 23)

Reprography Unit, ISI, New Delhi, India