

*Indian Standard*

**SPECIFICATION FOR  
CAST IRON DETACHABLE JOINTS FOR USE  
WITH ASBESTOS CEMENT PRESSURE PIPES**

**( *First Revision* )**

Second Reprint MARCH 1993

UDC 621.643.41 [ 669.13 ] : 621.693.2 — 986 [ 666.961 ]

© Copyright 1989

**BUREAU OF INDIAN STANDARDS  
MANAK BHAVAN, 9 BAHADUR SHAH ZAFAR MARG  
NEW DELHI 110002**

# Indian Standard

## SPECIFICATION FOR CAST IRON DETACHABLE JOINTS FOR USE WITH ASBESTOS CEMENT PRESSURE PIPES

( *First Revision* )

### 0. FOREWORD

**0.1** The Indian Standard ( First Revision ) was adopted by the Bureau of Indian Standards on 5 August 1988, after the draft finalized by the Pig Iron and Cast Iron Sectional Committee had been approved by the Structural and Metals Division Council.

**0.2** This standard was first published in 1978 covering the requirements of cast iron detachable joints to be used with asbestos cement pressure pipes conforming to IS : 1592-1970. With the revision of IS : 1592 in 1980, a need was felt to revise this standard in order to match with the requirements of IS : 1592-1980\*. In this revision, apart from this aspect, joints of classes 20 and 25, and sizes up to 600 mm have been added.

**0.3** Detachable joint comprises a cast iron centre collar and two flanges, together with two rubber rings. The assembly is bolted together. It should be noted that the joints are not intended to

\*Specification for asbestos cement pressure pipes ( *second revision* ).

### 1. SCOPE

**1.1** This standard covers the requirements for cast iron detachable joints to be used with asbestos cement pressure pipes conforming to IS : 1592-1980\*.

### 2. SUPPLY OF MATERIAL

**2.1** The general requirements relating to the supply of material shall be as laid down in IS : 1387-1967†.

### 3. MANUFACTURE

**3.1** The metal used for the manufacture of joints shall be of requisite quality conforming to any of the grade of IS : 210-1978‡.

\*Specification for asbestos cement pressure pipes ( *second revision* ).

†General requirements for the supply of metallurgical materials ( *first revision* ).

‡Specification for grey iron castings ( *third revision* ).

resist end thrust, and it is essential to adequately anchor end caps and bends.

**0.4** For bolts and nuts to be used for these joints, a reference to IS : 1363 (Part 1)-1984\* and IS : 1363 (Part 3)-1984\* may be made.

For rubber rings to be used for these joints, a reference to IS : 10292-1988† may be made.

**0.5** For the purpose of deciding whether a particular requirement of this standard is complied with, the final value, observed or calculated, expressing the result of a test or analysis, shall be rounded off in accordance with IS : 2-1960‡. The number of significant places retained in the rounded off value should be the same as that of the specified value in this standard.

\*Specification for hexagon head bolts, screws and nuts of product Grade C : Part 1 Hexagon head bolts ( size range M 5 to M 36 ) ( *second revision* ), and Part 3 Hexagon nuts ( size range M 1.6 to M 36 ) ( *second revision* ).

†Dimensional requirements for rubber sealing rings for CID joints in asbestos cement piping ( *first revision* ).

‡Rules for rounding off numerical values ( *revised* ).

**3.2** The various parts of detachable joints shall be stripped with all precautions necessary to avoid warping or shrinking defects. They shall be free from defects other than any unavoidable surface imperfections which results from the method of manufacture and which do not affect the use of joints. By agreement between the purchaser and the manufacturer, minor defects may be rectified.

**3.3** The joints shall be such that they could be cut, drilled or machined. In case of dispute, the castings may be accepted provided the hardness measured on the external unmachined surface does not exceed the Brinell hardness of 215 HBS.

### 4. MECHANICAL TESTS

**4.0** Mechanical tests shall be carried out during manufacture and at the most twice per day of castings. The results obtained are taken to

represent all the joints of all sizes made during the day.

**4.1 Tensile Tests** — Two tensile tests shall be made on bars cast from the same metal in accordance with the method specified in Appendix A. The results of the tests shall show a minimum tensile strength of 150 MPa (15 kgf/mm<sup>2</sup>).

**4.2 Brinell Hardness Tests** — For checking the Brinell hardness specified in 4.3, Brinell hardness tests shall be carried out on the test bars used for tests in 5.1. The test shall be carried out in accordance with IS : 1500-1983\*.

**4.3 Retest** — If any test piece representing a lot fails to pass the test in the first instance, two additional tests shall be made on test pieces made from the metal used from the same lot. Should either of these additional test pieces fail to pass the test, the lot shall be deemed as not complying with the standard.

## 5. HYDROSTATIC TESTS

**5.1 Hydrostatic test** shall be carried out for collars only. For this test, the collar shall be kept under pressure for 15 seconds, minimum; it may be struck moderately with a 700 g hammer. It should withstand the pressure test without showing any leakage or sweating or other defects of any kind. The hydrostatic test as far as possible shall be conducted before coating the collar.

**5.1.1** The collar shall withstand the test pressure specified in Table 1 of IS : 1592-1980† for the class of asbestos cement pressure pipes with which they are to be used. When collars are required for higher pressures, the test pressures are subject to special agreement between the purchaser and the manufacturer.

\*Method for Brinell hardness tests for metallic materials (second revision).

†Specification for asbestos cement pressure pipes (second revision).

## 6. DIMENSIONS AND MASS

**6.1 Dimensions** for the cast iron flanges and collars shall conform to Table 1 and Table 2 respectively for the nominal dia, DN and class specified.

NOTE 1 — Nominal diameter of detachable joints shall refer to the corresponding nominal diameter of the asbestos cement pressure pipes.

NOTE 2 — Cast iron detachable joints of nominal diameter more than 600 mm may also be manufactured. In such cases, detailed dimensions and tolerances may be as mutually agreed between the purchaser and the supplier.

**6.2 Diameter and length of bolts** to be used with cast iron flanges shall be as given in Table 3.

**6.3 Approximate mass of joints** (excluding rubber rings and bolts), calculated by taking the density of cast iron as 7.15 kg/cm<sup>3</sup> has been given in Table 4 for information.

**6.4 The diameter of engagement end of joints** shall match the corresponding outside diameter of asbestos cement pressure pipes of appropriate classes conforming to IS : 1592-1980\*.

## 7. TOLERANCES

**7.1 The tolerances on the various dimensions** shall be as follows :

<i>Dimensions</i>	<i>Tolerances</i> mm
Wall thickness of collar	—(1 + 0.05 t) (see Note)
Cored holes and other dimensions	± 2 for DN up to 300, and ± 2.5 for DN 350 and above
Drilled holes	± 1.5

where *t* is standard thickness of collars.

NOTE — No limit for plus tolerance is specified.

\*Specification for asbestos cement pressure pipes (second revision).

**TABLE 1 CAST IRON FLANGES**

( Clause 6.1 )

All dimensions in millimetres.

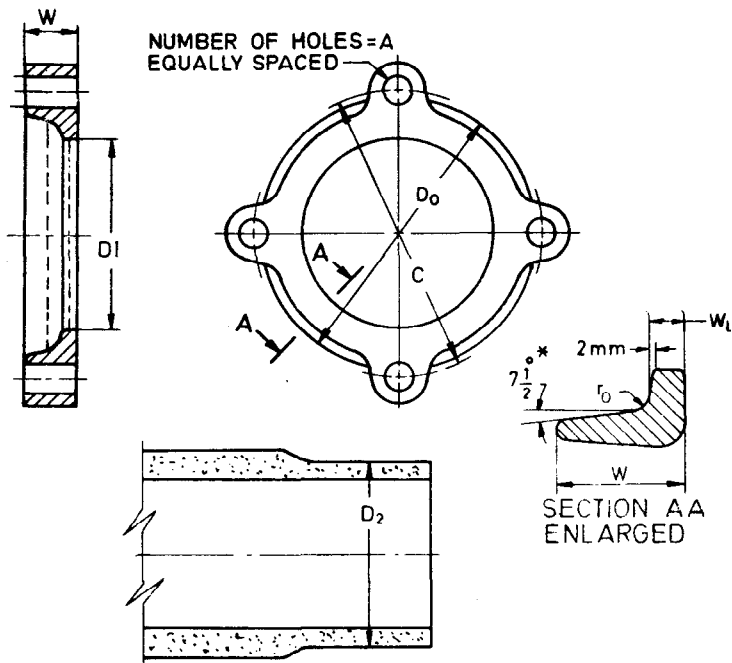

$D_2$  — Outside dimensions of asbestos cement pipes

\*This is for information only, however the internal slope of the flange and outer slope of the collar shall be such that there is no interference during assembly.

NOMINAL DIA	CLASS	EXTERNAL DIA OF AC PIPE	WIDTH OF FLANGE	LIP WIDTH OF FLANGE	INSIDE DIA OF FLANGE	OUTSIDE DIA OF FLANGE	INTERNAL RADIUS OF FLANGE*	BOLT CIRCLE DIA	HOLES	
									Dia	No.
DN		$D_2$	$W$	$W_L$	$DI$	$D_o$	$r_o$	$C$	( $d$ )	( $A$ )
(1)	(2)	(3)	(4)	(5)	(6)	(7)	(8)	(9)	(10)	(11)
80	5,10,15	99.5	27	8.0	103.5	147.0	5	154.5	16	3
	20	101.5	27	8.0	105.5	149.0	5	156.5	16	3
	25	106.5	27	8.0	110.5	154.0	5	161.5	16	3
100	5,10	120.0	27	8.0	124.0	168.5*	5	178.5	16	3
	15	121.0	27	8.0	125.0	169.5	5	179.5	16	3
	20	126.5	27	8.0	130.5	175.0	5	185.0	16	3
	25	132.5	27	8.0	136.5	179.5	5	189.5	16	3
125	5,10	145.0	29	8.5	149.0	191.0	5	200.0	16	4
	15	147.0	29	8.5	151.0	193.0	5	202.0	16	4
	20	152.5	29	8.5	156.5	198.5	5	208.5	16	4
	25	159.5	29	8.5	163.5	206.5	5	215.5	16	4
150	5,10	171.0	31	9.0	175.0	210.0	5	229.5	16	4
	15	176.5	31	9.0	180.5	224.5	5	235.0	16	4
	20	183.0	31	9.0	187.0	231.0	5	241.5	16	4
	25	191.0	31	9.0	195.0	240.0	5	250.5	16	4
200	5	221.0	35	9.5	225.0	275.0	5	282.0	20	4
	10	225.0	35	9.5	229.0	280.0	5	287.0	20	4
	15	233.5	35	9.5	237.5	287.5	5	294.5	20	4
	20	242.5	35	9.5	246.5	298.5	5	305.5	20	4
	25	253.5	35	9.5	257.5	309.5	5	316.5	20	4
250	5	271.0	35	10.0	275.0	328.0	5	333.0	20	4
	10	276.5	35	10.0	280.5	333.5	5	338.5	20	4
	15	284.5	35	10.0	288.5	341.5	5	346.5	20	4
	20	294.5	35	10.0	298.5	354.5	5	359.5	20	4
	25	305.5	35	10.0	309.5	365.5	5	370.5	20	4

( Continued )

**TABLE 1 CAST IRON FLANGES — Contd.**

NOMINAL DIA	CLASS	EXTERNAL DIA OF AC PIPE	WIDTH OF FLANGE	LIP WIDTH OF FLANGE	INSIDE DIA OF FLANGE	OUTSIDE DIA OF FLANGE	INTERNAL RADIUS OF FLANGE*	BOLT CIRCLE DIA	HOLES	
									Dia	No.
DN		$D_2$	$W$	$W_L$	$DI$	$D_o$	$r_o$	$C$	( $d$ )	( $A$ )
(1)	(2)	(3)	(4)	(5)	(6)	(7)	(8)	(9)	(10)	(11)
300	5	322.5	35	10.5	326.5	383.0	5	387.5	20	5
	10	328.5	35	10.5	332.5	389.0	5	393.5	20	5
	15	340.5	35	10.5	344.5	401.0	5	405.5	20	5
	20	352.5	35	10.5	356.5	417.0	5	421.5	20	5
	25	366.5	35	10.5	370.5	431.0	5	435.5	20	5
350	5,10	379.5	43	14.0	384.0	448.5	5	452.5	20	6
	15	392.0	43	14.0	396.5	463.0	5	467.0	20	6
	20	405.0	43	14.0	409.5	478.0	5	482.0	20	6
	25	419.0	43	14.0	423.5	494.0	5	498.0	20	6
400	5,10	432.0	45	15.0	436.5	504.0	5	509.0	20	6
	15	448.0	45	15.0	452.5	522.0	5	527.0	20	6
	20	463.0	45	15.0	467.5	539.0	5	544.0	20	6
	25	478.0	45	15.0	482.5	556.0	5	561.0	20	6
450	5,10	482.0	45	15.0	486.5	558.0	5	563.0	20	7
	15	498.0	45	15.0	502.5	576.0	5	581.0	20	7
	20	515.0	45	15.0	519.5	595.0	5	600.0	20	7
	25	532.0	45	15.0	536.5	614.0	5	619.0	20	7
500	5,10	536.5	50	18.0	541.0	623.5	6	629.5	24	8
	15	554.5	50	18.0	559.0	641.5	6	647.5	24	8
	20	572.5	50	18.0	577.0	661.5	6	667.5	24	8
	25	591.5	50	18.0	596.0	682.5	6	688.5	24	8
600	5,10	643.5	57	20.0	648.0	743.5	6	749.5	24	9
	15	665.5	57	20.0	670.0	767.5	6	773.5	24	9
	20	686.5	57	20.0	691.0	790.5	6	796.5	24	9
	25	710.5	57	20.0	715.0	816.5	6	822.5	24	9

NOTE — For DN 450, 8 number of bolts may also be used for a period of three years from the date of printing of this standard. Thereafter it shall stand withdrawn.

\*For information only.

**TABLE 2 CAST IRON COLLAR**

( Clause 6.1 )

All dimensions in millimetres.

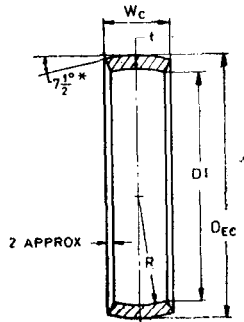

NOMINAL DIA	CLASS	EXTERNAL DIA OF AC PIPE	INSIDE DIA	EXTERNAL DIA AT CENTRE	COLLAR WIDTH	THICK-NESS	RADIUS OF CURVATURE*
DN		$D_2$	$DI$	$DEc$	$W_C$	$t$	$R$
(1)	(2)	(3)	(4)	(5)	(6)	(7)	(8)
80	5,10,15	99.5	103.5	129.0	38	9.0	34
	20	101.5	105.5	130.5	38	9.0	34
	25	106.5	110.5	136.0	38	9.0	34
100	5,10	120.0	124.0	150.5	42	9.0	50
	15	121.0	125.0	151.5	42	9.0	50
	20	126.5	130.5	156.0	42	9.0	50
	25	132.5	136.5	161.5	42	9.0	50

( Continued )

TABLE 2 CAST IRON COLLAR — *Contd*

NOMINAL DIA	CLASS	EXTERNAL DIA OF AC PIPE	INSIDE DIA	EXTERNAL DIA AT CENTRE	COLLAR WIDTH	THICKNESS	RADIUS OF CURVATURE*
<i>DN</i>		<i>D<sub>s</sub></i>	<i>DI</i>	<i>D<sub>EC</sub></i>	<i>W<sub>C</sub></i>	<i>t</i>	<i>R</i>
(1)	(2)	(3)	(4)	(5)	(6)	(7)	(8)
125	5,10	145·0	149·0	173·0	46	9·0	75
	15	147·0	151·0	175·0	46	9·0	75
	20	152·5	156·5	181·5	46	9·5	75
	25	159·5	163·5	188·5	46	9·5	75
150	5,10	171·0	175·0	201·0	50	9·5	80
	15	176·5	180·5	206·5	50	9·5	80
	20	183·0	187·5	213·0	50	10·0	80
	25	191·0	195·0	221·0	50	10·0	80
200	5	221·0	225·0	251·0	56	10·0	115
	10	225·0	229·0	256·0	56	10·0	115
	15	233·5	237·5	263·5	56	10·0	115
	20	242·5	246·5	274·5	56	11·0	115
	25	253·5	257·5	285·5	56	11·0	115
250	5	271·0	275·0	302·0	60	10·5	120
	10	276·5	280·5	307·5	60	10·5	120
	15	284·5	288·5	315·5	60	10·5	120
	20	294·5	298·5	328·5	60	12·0	120
	25	305·5	309·5	339·5	60	12·0	120
300	5	322·5	326·5	355·5	60	11·0	120
	10	328·5	332·5	361·5	60	11·0	120
	15	340·5	344·5	373·5	60	11·0	120
	20	352·5	356·5	389·5	60	13·0	120
	25	366·5	370·5	403·5	60	13·0	120
350	5,10	379·5	384·0	418·5	70	12·5	120
	15	392·0	396·5	434·0	70	14·0	120
	20	405·0	409·5	450·0	70	15·5	120
	25	419·0	423·5	467·0	70	17·0	120
400	5,10	432·0	436·5	473·0	70	13·5	120
	15	448·0	452·5	492·0	70	15·0	120
	20	463·0	467·5	510·0	70	16·5	120
	25	478·0	482·5	529·0	70	18·5	120
450	5,10	482·0	486·5	524·0	70	14·0	120
	15	498·0	502·5	544·0	70	16·0	120
	20	515·0	519·5	564·0	70	17·5	120
	25	532·0	536·5	585·0	70	19·5	120
500	5,10	536·5	541·0	583·0	80	15·0	125
	15	554·5	559·0	605·0	80	17·0	125
	20	572·5	577·0	627·0	80	19·0	125
	25	591·5	596·0	649·0	80	20·5	125
600	5,10	643·5	648·0	699·5	90	17·0	125
	15	665·5	670·0	725·5	90	19·0	125
	20	686·5	691·0	750·5	90	21·0	125
	25	710·5	715·0	779·5	90	23·5	125

\*For information only.

TABLE 3 DETAILS OF BOLTS

( Clause 6.2 )

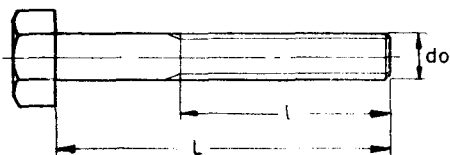

NOMINAL DIA OF JOINT	CLASS	NOMINAL DIA OF BOLTS	MINIMUM PREFERRED LENGTH OF BOLTS
DN		$d_o$	L
(1)	(2)	(3)	(4)
80	5 to 25	12	90
100	5 to 25	12	100
125	5 to 25	12	100
150	5 to 25	12	110
200	5 to 25	16	120
250	5 to 25	16	120
300	5 to 25	16	120
350	5 to 25	16	150
400	5 to 25	16	150
450	5 to 25	16	150
500	5 to 25	20	180
600	5 to 25	20	190

TABLE 4 MASS OF JOINTS ( APPROXIMATE )

( Clause 6.3 )

NOMINAL D.A DN	MASS OF JOINT ( APPROXIMATE, EXCLUDING RUBBER RING AND BOLTS ) IN kg FOR CLASS				
	5	10	15	20	25
(1)	(2)	(3)	(4)	(5)	(6)
80	3.0	3.0	3.0	3.1	3.2
100	3.8	3.8	3.8	3.9	4.0
125	4.8	4.8	4.8	5.4	5.6
150	6.1	6.1	6.3	6.4	6.8
200	8.6	9.0	9.0	9.7	10.1
250	12.0	12.2	12.5	13.8	14.3
300	14.7	14.9	15.4	17.5	18.1
350	24.8	24.8	26.5	28.1	29.8
400	30.1	30.1	31.4	33.8	35.8
450	35.7	35.7	38.0	40.6	42.8
500	50.3	50.3	54.1	56.6	60.1
600	80.8	80.8	84.8	91.4	95.5

## 8. COATING

8.0 After inspection, each part of joint shall be coated as specified in 8.1 to 8.6.

8.1 Coating shall not be applied to any part unless its surface is clean, dry and free from rust.

8.2 Unless otherwise agreed to between the purchaser and the manufacturer, all cast iron parts shall be coated externally and internally

with the same material, the parts being preheated prior to total immersion in a bath containing a uniformly heated composition having a bituminous tar or other suitable base.

NOTE — For joints used for carrying potable water, coal tar should not be used.

8.2.1 Alternatively, the coating on the cast iron parts may be done without preheating with two coats of black Japan conforming to Type C of IS : 341-1973\*, if agreed at the time of enquiry and order.

8.3 The coating material shall set rapidly with good adherence and shall not scale off.

8.4 In all instances where the coating material has a tar or similar base, it shall be smooth and tenacious, and hard enough not to flow when exposed to a temperature of 65°C but not so brittle at a temperature of 0°C as to chip off when scribed lightly with a penknife.

8.5 When the parts are to be used for conveying potable water, the inside coating shall not contain any constituent soluble in such water or any ingredient which could impart any taste or odour whatsoever to the potable water after sterilization and suitably washing of the mains.

8.6 In case of parts ( wholly or partially coated ) which is imperfectly coated or where the coating does not set or conform to the quality specified in 8.1 to 8.5, the coating shall be removed and the parts re-coated.

## 9. SAMPLING

9.1 The requirements for sampling and criteria for conformity shall be as given in Appendix B.

## 10. MARKING

10.1 Each joint shall have cast, stamped or indelibly painted on it the following appropriate marks:

- Manufacturer's name, initials or identification mark;
- Nominal diameter;
- Class reference;
- Last two digits for the year of manufacture; and
- Any other mark, if required by the purchaser.

11.1 The material may also be marked with the Standard Mark. The details are available with the Bureau of Indian Standards.

\*Specification for black Japan, Types A, B and C ( first revision ).

## APPENDIX A

( Clause 4.1 )

## TENSILE TEST

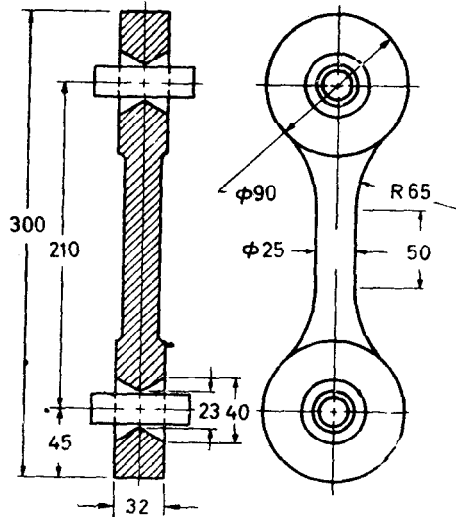

All dimensions in millimetres.

FIG. 1 TENSILE TEST SECTION

### A-1. TESTS ON BARS FOR C.I. DETACHABLE JOINT CAST IN SAND MOULDS

A-1.1 The tensile test bars are properly mould-

ed free from defects and are either unmachined or machined to give a diameter of about 20 to 25 mm. The ends are selected by the manufacturer to fit the testing machine. Figure 1 shows one satisfactory design.

## APPENDIX B

( Clause 9.1 )

## SAMPLING OF CAST IRON DETACHABLE JOINTS

## B-1. LOT

B-1.1 In any consignment, all the joints/collars manufactured under similar conditions shall be grouped together to constitute a lot.

B-1.1.1 Samples shall be taken and tested from each lot for ascertaining the conformity of the lot.

## B-2. SCALE OF SAMPLING

B-2.1 The number of joints/collars to be sampled shall be according to col 1 and 2 of Table 5. These joints/collars shall be taken at random ( see IS : 4905-1968\* ).

## B-3. NUMBER OF TESTS AND CRITERIA FOR CONFORMITY

B-3.1 The joints/collars selected according to col 1 and 2 of Table 5 shall be tested for dimensions, tolerances, coating and hydrostatic pressure tests. A joint/collar failing to meet the

TABLE 5 SCALE OF SAMPLING AND PERMISSIBLE NUMBER OF DEFECTIVES

( Clause B-2.1 )

LOT SIZE	SAMPLE SIZE	PERMISSIBLE NO. OF DEFECTIVE
N	n	a
(1)	(2)	(3)
Up to 500	8	0
501 to 1 000	13	1
1 001 to 3 000	20	2
3 001 to 10 000	32	3
10 001 and above	50	5

requirement of any of the tests, it shall be called a defective joint/collar.

B-3.1.1 If the number of defectives found in a lot is less than or equal to the corresponding number of permissible number of defectives, the lot shall be considered as conforming to the requirements of the standard, otherwise not.

\*Method for random sampling.



## Bureau of Indian Standards

BIS is a statutory institution established under the *Bureau of Indian Standards Act, 1986* to promote harmonious development of the activities of standardization, marking and quality certification of goods and attending to connected matters in the country.

### Copyright

BIS has the copyright of all its publications. No part of these publications may be reproduced in any form without the prior permission in writing of BIS. This does not preclude the free use, in the course of implementing the standard, of necessary details, such as symbols and sizes, type or grade designations. Enquiries relating to copyright be addressed to the Director (Publications), BIS.

### Revision of Indian Standards

Indian Standards are reviewed periodically and revised, when necessary and amendments, if any, are issued from time to time. Users of Indian Standards should ascertain that they are in possession of the latest amendments or edition. Comments on this Indian Standard may be sent to BIS giving the following reference:

#### Amendments Issued Since Publication

Amend No.	Date of Issue	Text Affected

## BUREAU OF INDIAN STANDARDS

### Headquarters:

Manak Bhavan, 9 Bahadur Shah Zafar Marg, New Delhi 110002  
Telephones : 331 01 31, 331 13 75

Telegrams : Manaksanstha  
( Common to all Offices )

### Regional Offices :

Central : Manak Bhavan, 9 Bahadur Shah Zafar Marg  
NEW DELHI 110002

Telephone.

{ 331 01 31  
331 13 75

Eastern : 1/14 C. I. T. Scheme VII M, V. I. P. Road, Maniktola  
CALCUTTA 700054

{ 37 84 99, 37 85 61  
37 86 26, 37 86 62

Northern : SCO 445-446, Sector 35-C, CHANDIGARH 160036

{ 53 38 43, 53 16 40  
53 23 84

Southern : C. I. T. Campus, IV Cross Road, MADRAS 600113

{ 235 02 16, 235 04 42,  
235 15 19, 235 23 15

Western : Manakalaya, E9 MIDC, Marol, Andheri ( East )  
BOMBAY 400093

{ 632 92 95, 632 78 58.  
632 78 91, 632 78 92

Branches : AHMADABAD, BANGALORE, BHOPAL, BHUBANESHWAR, COIMBATORE  
FARIDABAD, GHAZIABAD, GUWAHATI, HYDERABAD, JAIPUR, KANPUR  
LUCKNOW, PATNA, THIRUVANANTHAPURAM.

# AMENDMENT NO. 1 JULY 1991

TO

## IS 8794 : 1988 SPECIFICATION FOR CAST IRON DETACHABLE JOINTS FOR USE WITH ASBESTOS CEMENT PRESSURE PIPES

( *First Revision* )

( *Page 2, clause 4.2, line 2* ) — Substitute '3.3' for '4.3'.

( *Page 2, clause 4.2, line 4* ) — Substitute '4.1' for '5.1'.

( *Page 2, clause 6.3, line 3* ) — Substitute '7.15 kg/dm<sup>3</sup>' for '7.15 kg/cm<sup>3</sup>'.

( *Page 4, Table 1* ) — Substitute the following for the existing values of  $D_o$ , 'Outside Dia of Flange', col 7 ( from  $DN$  350 to  $DN$  600 ) and  $C$  'Bolt Circle Dia', col 9 ( from  $DN$  350 to  $DN$  600 ):

NOMINAL DIA $DN$ ( 1 )	OUTSIDE DIA OF FLANGE $D_o$ ( 7 )	BOLT CIRCLE DIA $C$ ( 9 )
350	448.0	452.0
	463.5	467.5
	479.5	483.0
	496.5	500.5
400	503.5	508.5
	522.5	527.5
	540.5	545.0
	559.5	564.5
450	556.5	561.5
	576.5	581.5
	596.5	601.5
	617.5	622.5
500	622.0	628.0
	642.0	648.0
	664.0	670.0
	686.0	692.0
600	742.0	748.0
	768.0	774.0
	793.0	799.0
	822.0	828.0

( *Page 6, Table 3* ) — Substitute the following figure for the existing figure:

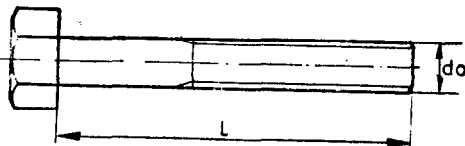

( Page 6, Table 4 ) — Substitute the following values for the existing values from DN 350 to DN 600:

NOMINAL DIA DN	MASS OF JOINT ( APPROXIMATE, EXCLUDING RUBBER RING AND BOLTS) IN kg FOR CLASS				
	5	10	15	20	25
( 1 )	( 2 )	( 3 )	( 4 )	( 5 )	( 6 )
350	24.7	24.7	26.5	29.2	31.5
400	29.7	29.7	31.4	35.1	38.5
450	34.5	34.5	38.0	41.1	45.1
500	50.0	50.0	54.1	59.7	64.0
600	78.2	78.2	84.8	91.8	100.5

( MTD 6 )

**AMENDMENT NO. 2 OCTOBER 1996**  
**TO**  
**IS 8794 : 1988 SPECIFICATION FOR CAST IRON**  
**DETACHABLE JOINTS FOR USE WITH ASBESTOS**  
**CEMENT PRESSURE PIPES**

*( First Revision )*

*( Page 2, clause 6.3 )* — Substitute the following for the existing clause>

**‘6.3** The mass of joints (excluding rubber rings and bolts), calculated by taking density of iron as  $7.15 \text{ kg/dm}^3$ , are given in Table 4. The permissible tolerance on specified mass of joints shall be  $\pm 8$  percent’ .

*( Page 6, Table 4 )* — Delete the word ‘Approximate’ wherever appearing in the table.

( MTD 6 )

---

Reprography Unit, BIS, New Delhi, India