

भारतीय मानक

पानी के मीटर (घरेलू किस्म) — विशिष्ट
(छटा पुनरीक्षण)

Indian Standard

WATER METERS (DOMESTIC TYPE) —
SPECIFICATION

(*Sixth Revision*)

UDC 68.1121

© BIS 1994

BUREAU OF INDIAN STANDARDS
MANAK BHAVAN, 9 BAHADUR SHAH ZAFAR MARG
NEW DELHI 110002

FOREWORD

This Indian Standard (Sixth Revision) was adopted by the Bureau of Indian Standards, after the draft finalized by the Sanitary Appliances and Water Fittings Sectional Committee had been approved by the Civil Engineering Division Council.

This standard was first published in 1956. The first, second, third, fourth and fifth revisions were issued in 1961, 1965, 1966, 1968 and 1978 respectively.

In this revision, the following major modifications have been effected:

- a) Various terms used in this standard have been broadly aligned with ISO 4064 (Part 1) : 1977 and EEC Council Directive.
- b) Indicating devices for reading the volume of water have been elaborated in three types namely with pointers, digital and combination of the two.
- c) Depending upon the metrological characteristics, Class A and Class B water meters have been introduced, based on ISO 4064 (Part 1) and EEC Council Directive. An additional class, namely Class 'O' (ordinary) has been added to serve the existing needs of the water meter industry. This class (class O) shall stand withdrawn after a period of 3 years from the date of printing of this standard.
- d) Type B water meter made with ferrous metal has been withdrawn.
- e) Pressure loss requirement has been made stringent in line with EEC Council Directive.
- f) Overall lengths of the meters have been specified both with nipples and without nipples.

In the preparation of this standard, considerable assistance has been derived from the following:

- a) ISO 4064/1 : 1977 Measurement of water flow in closed conduits — Meters for cold potable water: Part 1 Specification, issued by International Organization for Standardization.
- b) European Communities Council Directive 75/33/EEC of December 1974 on the approximation of the laws of the member states relating to cold-water meters, issued by the Council of European Communities.

The composition of the technical committee responsible for the formulation of this standard is given in Annex C.

For the purpose of deciding whether a particular requirement of this standard is complied with, the final value, observed or calculated, expressing the result of a test or analysis, shall be rounded off in accordance with IS 2 : 1960 'Rules for rounding off numerical values (revised)'. The number of significant places retained in the rounded off value should be the same as that of the specified value in this standard.

Indian Standard

WATER METERS (DOMESTIC TYPE) — SPECIFICATION

(Sixth Revision)

1 SCOPE

This standard covers terminology, construction, technical characteristics, metrological characteristics and other requirements of water meters with threaded end connections of size up to and including 50 mm, having nominal flow rates in the range of 1.5 to 15 kl/h, suitable for measuring the flow of cold potable water at a nominal pressure of 1 MPa¹⁾ (*Max*) and ambient temperature.

This standard is applicable both for semipositive (piston type) and inferential (turbine type) including magnetic type water meters having dry or wet dial.

2 REFERENCES

Indian Standards listed in Annex A are the necessary adjuncts to this standard.

3 TERMINOLOGY

For the purpose of this standard, the following definitions of the terms used shall apply.

3.1 Nominal Pressure

The internal pressure, expressed in MPa corresponding to the maximum permissible working pressure.

3.2 Flow Rate

The volume of water passing through the water meter per unit of time; the volume being expressed in litres and the time in hours, minutes or seconds.

3.3 Flow Delivered

The total volume of water which has passed through the meter in a given time.

3.4 Maximum Flow Rate, Q_{max}

The highest flow rate at which the meter can function over limited periods without damage and without exceeding the maximum permissible errors and the maximum permissible value for loss of pressure, expressed in kl/h.

3.5 Nominal Flow Rate, Q_n

Half the maximum flow rate, Q_{max} , expressed in kl/h.

At the nominal flow rate Q_n , the meter should be able to function in normal use, *i.e.* in continuous and intermittent operating conditions, without exceeding the maximum permissible errors.

3.6 Minimum Flow Rate, Q_{min}

The lowest flow rate at which the meter is required to give indications within the maximum permissible error tolerance. It is determined in terms of Q_n .

3.7 Flow Rate Range

The range limited by the maximum and the minimum flow rates (Q_{max} and Q_{min}). The range is divided into two zones called upper and lower zones, separated by the transitional flow rate Q_t .

3.8 Transitional Flow Rate, Q_t

The flow rate which divides the upper and lower regions of the flow range and the rate at which the maximum permissible errors become discontinuous.

3.9 Pressure Loss

The pressure loss caused by the presence of the water meter in the pipe line.

3.10 Water Meter, Inferential Type

Meter which measures the velocity of flow from which the discharge is measured.

3.11 Water Meter, Semipositive Type

Meter which volumetrically records practically down to zero flow of the water that has passed through, with a small unavoidable leakage.

4 NOMINAL SIZE

4.1 Water meters shall be of the following nominal sizes : 15, 20, 25, 40 and 50 mm.

The nominal size of the water meter is denoted by the nominal bore of its end connections.

5 CLASSES OF WATER METERS

Based on the maximum verification scale interval (*see* 8.3) and metrological characteristics (*see* 11), meters have been classified as class 'O', class 'A' and class 'B'.

6 MATERIALS

6.1 Water meters shall be made of materials of adequate strength and stability for the purpose for which the water meter is to be used. It must be constructed throughout of materials which are resistant to internal and normal external corrosion and if necessary be protected by some suitable surface treatment. Parts coming in contact with water shall be made of materials resistant to corrosion and shall be nontoxic and nontainting. Use of dissimilar metals in contact under water

¹⁾ 1MPa = 1 N/mm² = 9.8 kgf/cm².

should be avoided as far as possible in order to minimize electrolytic corrosion. Water temperature variation within the temperature range specified must not adversely affect the materials used in the construction of the water meter.

A list of materials recommended for manufacture of body and component parts of water meters is given in Annex B.

6.1.1 Plastics used in the manufacture of various components listed at Annex B shall also meet the following requirements:

- a) It should not affect the potability of water.
- b) Elongation, 15 percent, *Min*, on a specimen of length 150 mm (for procedure of determination of elongation see A-7 of IS 2267 : 1972).
- c) Water absorption on immersion for 24 h should not exceed 0.6 percent by weight (for procedure of determination of water absorption see B-7 of IS 2267 : 1972).
- d) It should be capable of withstanding temperature up to 55°C without undergoing deformation or softening and becoming unsatisfactory in performance.

7 CONSTRUCTION

7.1 General

The meters shall be constructed in such a way as to:

- a) give long service and guarantee against any fraud or tampering; and
- b) conform with the provisions of this standard, under normal conditions of use.

Where meters may be subjected to an accidental reversal of flow they must be capable of withstanding it without any deterioration or change of their metrological properties, and at the same time should not record such a reversal.

7.2 Body

The body shall be free from all manufacturing and processing defects, such as blow-holes and spongy structure and shall not be repaired by plugging, welding or by the addition of materials. The internal shape of the body shall ensure smooth flow of water and easy dismantling.

7.3 Registration Box

The Registration box of dry-dial water meters may be provided with escape hole(s) for minimizing the accumulation of water. In the case of magnetic driven type or where the registration box and cap are integral with the body, no escape hole shall be provided.

7.4 Cap

Where the cap and registration box are integral, the material for cap shall be the same as used for registration box. The cap shall be so designed and fixed to the registration box as to avoid entry of water and dirt. The transparent window which covers the dial shall be inserted from the inside into the cap. The protective lid shall be secured by a robust hinge or other suitable

method of robust construction. Cap ring where applicable should be of the same material as of the cap.

7.4.1 Where so required for dry-type water meters, the transparent window covering the dial shall be provided with a wiper on the inner side for wiping off condensed water.

7.5 Connections

The meter casing shall be fitted in the pipe line by means of two cylindrical nipples or tail pieces with connecting nuts which shall be provided with each meter. The threads on the connection shall conform to IS 2643 (Parts 1 to 3) : 1975.

7.6 Strainers

Water meters shall be provided with strainers. They shall be rigid, easy to remove and clean and shall be fitted on the inlet side of the water meter. It shall be possible to remove and clean the strainer in such a way as not to disturb the registration box or tampering with it. The strainer shall have a total area of holes not less than twice the area of the nominal inlet bore of the pipe to which the meter is connected except in the case of single jet inferential type of meters. The free area of holes shall be such that it complies with the headloss at nominal and maximum flow rates. However, in the case of meters provided with internal strainer involving opening of the registration box for cleaning, an additional external strainer shall be fitted on the inlet side satisfying the above requirements.

7.7 Impeller and Pistons

7.7.1 Impeller and impeller shaft assembly shall rest on a self-lubricating bearing which has as low frictional resistance as possible (see 7.10).

7.7.2 Rotary or oscillating pistons in the case of semi-positive type meters shall be of non-absorbent material, such as vulcanite or ebonite. Pistons shall be accurately finished and shall operate freely with as low a frictional resistance as possible.

7.8 Impeller Chamber and Measuring Chamber

The impeller chamber and measuring chamber shall be rigid and shall not change its form as a result of internal stresses or with use.

7.9 Gears and Pinions

Gears and pinions shall be constructed to properly and smoothly mesh with each other, and shall be firmly fitted on their shafts.

7.10 Bearings

Impeller bearings shall be suitably grounded and polished. The shape of the impeller bearing shall be such as to prevent the penetration of particles of sand and to preclude the deposit of anything in solution or suspension in water and to facilitate the washing away of such deposits by the water flow. The shafts of the gears shall revolve freely in their bearings. The length of the bearings shall ensure their effective operations.

7.11 Counter

The counter shall be of the circular multi-pointer pattern with all pointers reading clockwise or of the

straight reading cyclometer type or a combination of pointer and cyclometer. The rollers of the cyclometer counters shall be made of plastics specially suitable for the purpose and shall be self-lubricating. The pointer(s) shall be of brass sheet or plastic and shall be soldered to the spindle.

7.12 Dial

The dial shall be of vitreous enamel powder coated on copper or plastics ensuring indestructible marking and good legibility.

7.13 Regulator

Every inferential meter shall be provided either with external/internal regulator. The external regulator shall be accessible from outside to be operated by suitable key without dismantling the meter and not without breaking the seal. The internal regulating device shall not be accessible from outside.

7.14 Sealing

Sealing holes shall be provided and the meter shall be sealed in such a manner as to render it impossible to obtain access to the measuring unit including registration box and cap without breaking the seals. The sealing wires shall be rust proof material.

7.15 Frost Protection Device

Meters liable to be damaged by frost when so ordered by the purchaser shall be protected with suitable frost protection devices. Several devices are adopted and the following which have been found to give satisfactory performance, are given as typical examples:

- Provisions of pads or special quality rubber which accommodate an increase in bulk of water when it freezes.
- Provision of collapsible metal ring which under frost pressure allows the top plate carrying the mechanism to lift and so safeguards the body, or metal disc in the body which gives way under pressure. It should be noted that the damaged ring or plate requires immediate replacement to restore water supply to user or to stop wastage.

8 INDICATING DEVICE

8.1 Indicating device shall be able to record 9999 kl (min) for meter size of 15, 20 and 25 mm and 99999 kl (min) for size 40 and 50 mm and shall thereafter indicate zero.

8.2 The indicator shall allow, by simple juxtaposition of its various constituent elements, a reliable, easy and unambiguous reading of the volume of water measured, expressed in litres. The volume is indicated by one of the following systems:

- the position of one or more pointers on circular scales;
- reading of a row of in-line consecutive digits in one or more apertures;
- a combination of these two systems.

8.2.1 The kilo-litres and its multiples shall be indicated

in black and sub-multiples of the kilo-litres in red. This colour coding applies to the pointers on circular scale type indicating devices and to the drum in in-line digit indicating devices. The actual or apparent height of the digits on the drums shall not be less than 4 mm.

For digital indicators the visible displacement of all digits shall be upward in value. The advance of any given digital unit shall be completed while the digit of the immediately next lower value describes the last tenth of its travel. The drum showing the digits of lowest value may move continuously. The whole number of kilo-litres shall be clearly indicated.

8.2.2 Indicators with pointer shall rotate in a clockwise direction. The value in litres for each scale division shall be expressed as 10^n , where n is a positive or negative whole number or zero, thereby establishing a system of consecutive decades. Each scale shall be either:

- graduated in values expressed in litres, or
- accompanied by a multiplying factor (x.001, x.01, x 0.1, x1, x10, x100, x1 000, etc)

8.2.3 In both cases (dial and digital indicators):

- the unit symbol 'KILO-LITRES' shall appear either on the dial or in the immediate vicinity of the digital indication;
- the fastest-moving visible graduated element, the control element, the scale interval of which is known as the "verification scale interval", shall move continuously.

8.2.4 The length of verification scale interval shall be not less than 1 mm and not more than 5 mm. The scale shall consist:

- either of lines of equal thickness not exceeding one quarter of the distance between the axes of two consecutive lines and differing only in length, or
- of contrasting bands of a constant width equal to the length of the scale division.

The width of the pointer index tip shall not exceed one quarter of the distance between two scale divisions, and in no case shall it be greater than 0.5 mm.

8.3 Value of Verification Scale Division

Verification scale interval for Class 'O', Class 'A' and Class 'B' meters shall be as given in Table 1.

Table 1 Verification Scale Interval

Meter Size	Maximum Value of Verification Scale Interval, litres		
	Class O	Class A	Class B
15	1.0	0.2	0.2
20	1.0	0.5	0.2
25	1.0	1.0	0.5
40	10.0	2.0	1.0
50	10.0	2.0	2.0

8.4 Accelerating Device

The use of an acceleration device for increasing the speed of the meter below Q_{min} is prohibited.

9 METER SIZE AND OVERALL DIMENSIONS

9.1 For each meter size there is a corresponding fixed

set of overall dimensions. The dimensions shall be as given in Table 2.

NOTE – Meter size and hence overall dimensions are in principle linked to the nominal flow rate (Q_n) of the water meter as specified in Table 2.

Table 2 Meter Size, Threads, Nominal Flow Rates and Dimensions

All dimensions in millimetres.

Meter Size	Threads	Nominal Flow Rate, Q_n in kl/h	Minimum Length of Threads on Either End of Body (see Fig. 2)		Overall Dimensions (see Fig. 1)						
					Length, L			Width, W (Max)		Height (Max)	
					With nipples	Without nipples		H ₁	H ₂		
						Preferred	Alternate ¹⁾				
(1)	(2)	(3)	(4)	(5)	(6)	(7)	(8)	(9)	(10)	(11)	
15	G $\frac{3}{4}$ B	1.5	10	12	250	165	110	100	50	180	
20	G 1B	2.5	12	14	290	190	165	130	60	240	
25	G $1\frac{1}{4}$ B	3.5	12	16	380	260	–	170	65	260	
40	G 2B	10	13	20	430	300	–	210	75	300	
50	G $2\frac{1}{2}$ B	15	15	25	470	330	–	270	115	300	

NOTE – Meters shall be supplied with nuts and nipples unless specified otherwise by the purchaser.

¹⁾ For single jet water meters only.

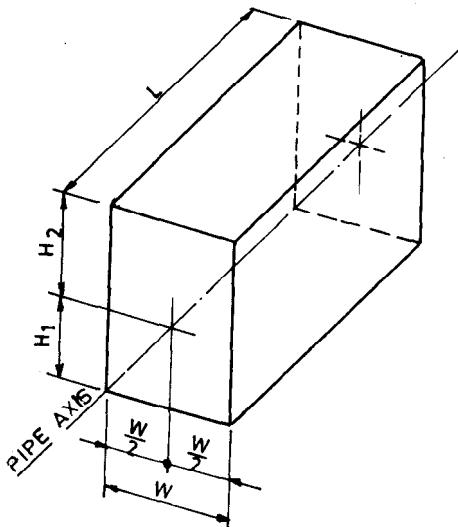

FIG. 1 OVERALL DIMENSIONS OF WATER METERS

9.1.1 Tolerance on the overall length shall be ± 5 mm for meter with nipples and $+0, -2$ mm for meters without nipples.

10 TECHNICAL CHARACTERISTICS

10.1 Pressure Tightness

A meter shall be able to withstand constantly without

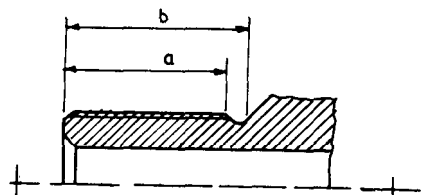

FIG. 2 THREAD LENGTHS

defects in its functioning, leakage, seepage through the walls or permanent deformation, the continuous water pressures of (i) 1.6 MPa for 15 minutes, and (ii) 2 MPa for 1 minute, when tested in accordance with IS 6784 : 1984.

10.2 Loss of Pressure

Loss of pressure through the meter when determined in accordance with IS 6784 : 1984 shall not exceed 0.025 MPa at the nominal flow rate Q_n , and 0.1 MPa at the maximum flow rate, Q_{max} .

NOTE - Nominal flow rate Q_n shall be taken as per Table 2 and maximum flow rate Q_{max} as twice the nominal flow rate.

10.3 Temperature Suitability

This test shall be carried out in accordance with IS 6784 : 1984.

11 METROLOGICAL CHARACTERISTICS

11.1 Metering Accuracy

The maximum permissible error in the metering accuracy, when determining as per IS 6784 : 1984 shall be as under:

- a) In the lower region of flow, $\pm 5\%$
 Q_{min} (inclusive) to Q_t (exclusive)
- b) In the upper region of flow, $\pm 2\%$
 Q_t (inclusive) to Q_{max} (inclusive)

NOTE - Value of Q_{min} , Q_t and Q_{max} for the three classes of water meters are given in Table 3.

11.2 Minimum Starting Flow

The minimum flow at which the meter starts registering shall be as given in Table 3 for the three classes of water meters. The test shall be carried out in accordance with IS 6784 : 1984.

12 TESTS

12.1 Classification of Tests

Tests classified into three groups, namely (a) production routine tests, (b) type test, and (c) acceptance tests shall be carried out as specified in the following clauses.

12.1.1 Production Routine Test

These tests (see 12.3) shall be conducted on each and every meter after completion at the works.

12.1.2 Type Tests

These tests (see 12.4) are necessary to check the performance and characteristics of the meter and its components and shall be carried out by a recognized testing authority (may be the manufacturer, if approved by the purchaser). Once a meter has undergone type tests, any major or essential alternations, which the manufacturer intends to make, shall be reported to the testing authority and further type tests shall be carried out in accordance with the procedure laid down in this standard.

12.1.3 Acceptance Tests

If the purchaser desires any of the production routine test to be repeated at the time of purchase, then, where agreed between the purchaser and the manufacturer, these tests may be carried at the manufacturer's works, or at the place specified by the purchaser, provided that all the arrangements for the test are made by the purchaser at the specified place.

12.2 Samples for Tests

12.2.1 Type Tests

Three water meters of same size, and class shall be sent along with six copies of the manufacturer's detailed specification with figures for the loss of head and accuracy curves, to a recognized testing authority for the purpose of type tests.

Table 3 Minimum Starting Flow Rate, Transitional Flow Rate and Maximum Flow Rate Values

Meter Size	Minimum Starting Flow Rate Q_{min} l/h for			Transitional Flow Rate, Q_t l/h for			Maximum Flow Rate Q_{max} kl/h
	Class O	Class A	Class B	Class O	Class A	Class B	
(1)	(2)	(3)	(4)	(5)	(6)	(7)	(8)
15	90	60	30	180	150	120	3
20	150	100	50	300	250	200	5
25	210	140	70	420	350	280	7
40	600	400	200	1 200	1 000	800	20
50	900	600	300	1 800	1 500	1 200	30

12.2.2 Acceptance Test**12.2.2.1 Lot**

In any consignment all the water meters of the same size and class manufactured by the same firm under similar conditions of production from material of the same batch, components from the same source, etc, shall be grouped together to constitute a lot.

12.2.2.2 The samples of water meters from a lot shall be selected at random or by random selection. The procedure for simple random sampling or systematic sampling as given in IS 4905 : 1968 may be adopted.

12.2.2.3 Scale of sampling

The first sample size of water meters from a lot shall be selected in accordance with col 1 and 2 of Table 4. Each meter in the sample shall be subjected to acceptance tests. If a decision to accept or reject the lot on the basis of first sample is not possible (*see 12.2.2.5*), the second sample of water meter shall be taken from the same lot in accordance with col 1 and 5 of Table 4 and each meter of the second sample shall be subjected to acceptance tests.

12.2.2.4 Any sample of water meter failing in any one or more of the acceptance tests shall be considered as a defective for the purpose of **12.2.2.1**.

12.2.2.5 Criteria for acceptance

If in the first sample, the number of defective meters is less than or equal to the corresponding acceptance number a_1 as given in col 3 of Table 4, the lot shall be declared as passing the acceptance tests. If the number of defective meters is greater than or equal to the corresponding rejection number r_1 given in col 4 of Table 4, the lot shall be declared as not passing the acceptance tests. If the number of defectives is greater than the acceptance number a_1 but less than the rejection number r_1 , the second sample of size equal to that

of the first sample shall be taken and subjected to acceptance tests. The number of defective meters found in the first and the second sample shall be added and if the cumulative number of defectives thus obtained are less than or equal to the acceptance number a_2 given in col 7 of Table 4, the lot shall be declared as passing the acceptance tests, otherwise it shall be rejected.

12.3 Production Routine Tests

Production routine tests shall consist of:

- a) Pressure tightness (*see 10.1*);
- b) Loss of pressure (*see 10.2*);
- c) Metering accuracy (*see 11.1*); and
- d) Minimum starting flow (*see 11.2*).

12.4 Type Tests

The type tests shall comprise and be carried out in the following order.

12.4.1 Pressure Tightness Test

All the three meters shall be subjected to the hydrostatic test (*see 10.1*).

12.4.2 Flow Test

All the three meters shall then be subjected to the flow test to measure the following:

- a) Pressure loss (*see 10.2*)
- b) Metering accuracy (*see 11.1*)
- c) Minimum starting flow (*see 11.2*), and
- d) Temperature suitability (*see 10.3*).

NOTE – Before the meter is subjected to the flow test, it shall be brought to normal condition by passing through it water at nominal flow rate for a period of two hours.

12.4.3 Construction

One of the three meters shall be dismantled completely to its component parts and checked for conformity with

Table 4 Sample Size and Criteria for Acceptance*(Clauses 12.2.2.3 and 12.2.2.5)*

Size of the Lot	Size of First Sample	Acceptance Number	Rejection Number	Size of Second Sample	Size of Cumulative Sample	Cumulative Acceptance Number
		(a_1)	(r_1)	(if required)		(a_2)
(1)	(2)	(3)	(4)	(5)	(6)	(7)
Up to 50	5	0	1	–	–	–
51 to 150	13	0	2	13	26	1
151 to 280	20	0	3	20	40	3
281 to 500	32	1	4	32	64	4
501 to 1 200	50	2	5	50	100	6
1 201 to 3 200	80	3	7	80	160	8

regard to dimensions and tolerances with this standard. A study of the detailed assembly shall also be made. The meter shall then be reassembled and reports shall be made on matters, such as ease of assembly, assembled and absence of riveted or turned over parts, forced fitting and liability of parts to break during dismantling and assembly.

12.4.4 Life Test (Accelerated Endurance Test)

The two unopened meters shall then be subjected to the life test as prescribed in IS 6784 : 1984.

12.4.4.1 After the meters have undergone the life test, they shall again be subjected to tests described under **12.4.1** and **12.4.2**. They shall be deemed satisfactory if their performance after the life test satisfies the requirements given in **12.4.1** and **12.4.2**.

12.4.4.2 One of the meters which have undergone the life test (preferably the one that has shown greater deterioration in its performance under the flow test) shall be dismantled completely and examined with a view to ensuring that there is no undue wear or distortion. Particular attention shall be paid during examination to the wear of the actuating unit comprising vane wheel or piston, the impeller shaft and measuring

chamber, bearings, gears and pinions, pivots and the gland packing.

12.5 The report of tests shall be furnished in accordance with IS 6784 : 1984.

13 MARKING

13.1 Each water meter shall be marked/embossed with the following information:

- a) Manufacturer's name or trade-mark,
- b) Nominal size and class of water meter,
- c) Direction of flow of water on both sides of the body of water meter, and
- d) Year of manufacture and serial number.

13.2 BIS Certification Marking

Water meter may also be marked with the Standard Mark.

13.2.1 The use of the Standard Mark is governed by the provisions of the *Bureau of Indian Standards Act, 1986* and the Rules and Regulations made thereunder. Details of conditions under which a licence for the use of the Standard mark may be granted to manufacturers or producers may be obtained from the Bureau of Indian Standards.

ANNEX A

(Clause 2)

LIST OF REFERRED INDIAN STANDARDS

IS No.	Title	IS No.	Title
292 : 1983	Lead brass ingots and castings (<i>second revision</i>)	2643	Dimensions for pipe threads for fastening purposes:
318 : 1981	Lead tin bronze ingots and castings (<i>second revision</i>)	(Part 1) : 1975	Basic profiles and dimensions (<i>first revision</i>)
319 : 1989	Free cutting brass bars, rods and sections (<i>fourth revision</i>)	(Part 2) : 1975	Tolerances (<i>first revision</i>)
320 : 1980	High tensile brass rods and sections (other than forgings stock) (<i>second revision</i>)	(Part 3) : 1975	Limits of sizes (<i>first revision</i>)
410 : 1977	Cold rolled brass sheet, strip and foil (<i>third revision</i>)	4131 : 1967	Nickel copper alloy castings
531 : 1981	Lead brass strip for instrument parts (<i>second revision</i>)	4905 : 1968	Methods for random sampling
1264 : 1989	Brass gravity die castings (ingots and castings) (<i>third revision</i>)	6603 : 1972	Stainless steel bars and flats
2267 : 1972	Polystyrene moulding materials (<i>first revision</i>)	6784 : 1984	Methods for performance testing of water meters (domestic type) (<i>first revision</i>)
		6911 : 1992	Stainless steel plate, sheet and strip (<i>first revision</i>)
		7328 : 1992	High density polyethylene materials for moulding and extrusion (<i>first revision</i>)

ANNEX B
(*Clauses 6.1 and 6.1.1*)

MATERIALS FOR BODY AND COMPONENT PARTS OF WATER METERS

<i>Body/Component Part of Water Meter</i>	<i>Materials</i>	<i>Ref to IS</i>
Body	a) Bronze	Grade LTB2 of IS 318 : 1981
	b) Brass	Grade DCB2 of IS 1264 : 1989
Registration box	a) Bronze	Grade LTB2 of IS 318 : 1981
	b) Brass	Grade LCB 3 of IS 292 : 1983 Grade DCB 2 of IS 1264 : 1989
	c) Plastic	ABS/Acetol polymer
Cap/cover/capring	a) Bronze	Grade LTB 2 of IS 318 : 1981
	b) Brass	Grade LCB 2 of IS 292 : 1983 Grade DCB 2 of IS 1264 : 1989
	c) Plastics	ABS/Acetol polymer
	d) Stainless steel	Designation 07Cr18Ni9 of IS 6911 : 1992
Screws and studs	a) High tensile brass	IS 320 : 1980
	b) Stainless steel	Designation 07Cr18Ni9 of IS 6911 : 1992
Strainers	a) Plastics	HDPE (<i>see</i> IS 7328 : 1992)
	b) Brass	Grade LCB 2 of IS 292 : 1983
	c) Stainless steel	Designation 07Cr18Ni9 of IS 6911 : 1992
Impellers, pistons and chambers	a) Ebonite (for piston only)	ABS/High impact polysterene/Acetol polymer
	b) Vulcanite (for piston only)	
	c) Plastics	
Impeller shaft	a) Stainless steel	Designation 07Cr18Ni9 of IS 6603 : 1972
	b) High tensile brass	Grade HT1 or HT2 in M condition of IS 320 : 1980
Nipples and nuts	a) Brass	Grade LCB 2 of IS 292 : 1983 Grade DCB 2 of IS 1264 : 1989
	b) Bronze	Grade LTB 2 of IS 318 : 1981
Measuring chamber	a) Brass	Grade LCB 2 of IS 292 : 1983
	b) Bronze	Grade LTB 2 of IS 318 : 1981
(Semi positive meters only)		
Gears, gearshaft and pinions	a) <i>For use under water</i>	
	i) Stainless steel	Designation 07Cr18Ni9 of IS 6603 : 1972
	ii) Nickel alloy	IS 4131 : 1967
	iii) Plastics	ABS/Acetol co-polymers

NOTE – Stainless steel shaft should preferably be used with plastic gears/pinions.

<i>Body/Component Part of Water Meter</i>	<i>Materials</i>	<i>Ref to IS</i>
	b) For use above water	
	i) Brass rod	Grade 1 half hard of IS 319 : 1989
	ii) Brass sheet (for gears only)	Grade CuZnPb2, half hard of IS 531 : 1981
	iii) Stainless steel	Designation 07Cr18Ni9 of IS 6603 : 1972
	iv) Plastics	ABS/Acetol Co-polymer
Bearings	a) Agate	
	b) Sapphire (Synthetic)	-
	c) Graphite filled nylon	-
	d) Sintered bearing	
Counter	a) Sheet brass	IS 410 : 1977
	b) Plastics	ABS/Acetol co-polymer
Dial	a) Copper duly enamelled or powder coated	

ANNEX C

(Foreword)

COMMITTEE COMPOSITION

Sanitary Appliances and Water Fittings Sectional Committee, CED 3

<i>Chairman</i>	<i>Representing</i>
SHRI S. PRAKASH	Delhi Water Supply & Sewage Disposal Undertaking (MCD), Delhi
<i>Members</i>	
SHRI P. K. JAIN (<i>Alternate</i> to Shri S. Prakash)	
THE ADVISER (PHE)	Central Public Health and Environmental Engineering, New Delhi
DEPUTY ADVISER (PHE) (<i>Alternate</i>)	
SHRI J. R. AGGARWAL	Goverdhan Das P.A. (Calcutta)
SHRI SANJAY AGGARWAL (<i>Alternate</i>)	
SHRI VIDUR BHASKAR	Bhaskar Stoneware Pipes Pvt Ltd, Faridabad
SHRI ARUN KANTI BISWAS	National Environmental Engineering Research Institute (CSIR), Nagpur
CHIEF ENGINEER (RURAL)	Maharashtra Water Supply and Sewage Board, New Bombay
DR T. K. DAN	Central Glass & Ceramic Research Institute (CSIR), Calcutta
SHRI G. DAMODARAM	E. I. D. Parry (India) Ltd, Madras
SHRI V. GOPAL (<i>Alternate</i>)	
HYDRAULIC ENGINEER	Municipal Corporation of Greater Bombay, Bombay
DEPUTY HYDRAULIC ENGINEER (<i>Alternate</i>)	
SHRI D. K. KANUNGO	National Test House, Calcutta
SHRI R. KAPOOR (<i>Alternate</i>)	
THE MANAGING DIRECTOR	Kerala Water Authority, Trivandrum
CHIEF ENGINEER (PS & G) (<i>Alternate</i>)	
SHRI K. LAKSHMI NARAYANA	Hindustan Shipyard Ltd, Visakhapatnam
SHRI A. SHARIF (<i>Alternate</i>)	
SHRI S. K. NEOGI	Institution of Public Health Engineers India, Calcutta
SHRI A. K. SENGUPTA (<i>Alternate</i>)	
SHRI O. P. RATRA	Building Material and Technology Promotion Council, New Delhi
SHRI R. S. ROTITHOR	Kirloskar Brothers Limited, Pune
SHRI S. D. JOSHI (<i>Alternate</i>)	
LT.COL S. K. SHARMA	Engineer-in-Chief's Branch, Ministry of Defence, Army Headquarters, New Delhi
LT.COL G. T. KAUSHIK (<i>Alternate</i>)	

(Continued on page 10)

(Continued from page 9)

Members

SHRI D. K. SEHGAL
 SHRI B. B. SIKKA (*Alternate*)
 SENIOR CIVIL ENGINEER (WATER SUPPLY)
 SHRI R. C. SHARMA
 SHRI SUDESH KUMAR SHARMA
 SHRI SURESH KUMAR SHARMA (*Alternate*)
 SUPERINTENDING ENGINEER (TAC)
 EXECUTIVE ENGINEER (TAC) (*Alternate*)
 SHRI R. K. SOMANY
 SHRI SANDIP SOMANY (*Alternate*)
 SUPERINTENDING SURVEYOR OF WORKS (NDG)
 EXECUTIVE ENGINEER (S&S) (*Alternate*)
 SHRI S. SUNDARAM
 REPRESENTATIVE
 REPRESENTATIVE
 SHRI J. VENKATARAMAN,
 Director (Civ Engg)

Representing

Leader Engineering Works, Jalandhar
 Ministry of Railways (Railway Board), New Delhi
 Directorate General of Supplies & Disposals, New Delhi
 Central Building Research Institute, Roorkee
 U. P. Jal Nigam, Lucknow
 Hindustan Sanitaryware Industries Ltd, Bahadurgarh
 Central Public Works Department, New Delhi
 Glass Fibre Division, Ceat Ltd, Hyderabad
 Central Institute of Plastic Engineering & Technology, Madras
 Institution of Engineers (India), New Delhi
 Director General, BIS (*Ex-officio Member*)

Member Secretary

SHRI S. S. SETHI
 Director (Civ Engg), BIS

Water Meters Subcommittee, CED 3 : 4

Convener

SHRI S. PRAKASH

Delhi Water Supply & Sewage Disposal Undertaking, New Delhi

Members

SHRI K. C. JAIN (*Alternate to Shri S. Prakash*)
 SHRI M. L. BHANSALY
 SHRI K. S. BHANSALY (*Alternate*)
 DR D. K. BISWAS
 SHRI S. K. BOHRA
 SHRI M. S. BISSA (*Alternate*)
 SHRI S. K. BOHRA
 CHIEF ENGINEER
 SUPERINTENDING ENGINEER (*Alternate*)
 CHIEF ENGINEER (PPR&D)
 SUPERINTENDING ENGINEER (*Alternate*)
 DIRECTOR
 SHRI A. GHOSH
 SHRI B. K. ROY (*Alternate*)
 HYDRAULIC ENGINEER
 DEPUTY HYDRAULIC ENGINEER (*Alternate*)
 SHRI M. P. JAIPURIA
 SHRI S. A. KHAN (*Alternate*)
 SHRI DAVIS P. MANAVALAN
 SHRI T. M. S. KUMAR (*Alternate*)
 SHRI A. S. NANDEDKAR
 SHRI Y. M. NINGAONKAR (*Alternate*)
 SHRI G. C. NARANG
 SHRI V. N. SINHA
 SHRI M. P. SHAHANI
 SHRI A. S. DESHPANDE (*Alternate*)

Rajkamal Water Meter Mfg Co, Calcutta
 Central Mechanical Engineering Research Institute (CSIR), Durgapur
 Rajasthan Industrial & Scientific Corporation, Jaipur
 All India Water Meters Manufacturer's Association, Jaipur
 Public Health Engineering Department, Government of Rajasthan, Jaipur
 U. P. Jal Nigam, Lucknow
 Directorate of Weights & Measures (Ministry of Commerce), New Delhi
 National Test House, Calcutta
 Municipal Corporation of Greater Bombay, Bombay
 Capstan Meters (India) Ltd, New Delhi
 Anand Water Meter Manufacturing Co, Cochin
 N. B. Industries (Meters) Pvt Ltd, Indore
 Indfos Industries Ltd, New Delhi
 Schlumberger Industries India Ltd, New Delhi
 Kaycee Industries, Bombay

(Continued on page 11)

(Continued from page 10)

Members

SHRI H. S. SURYANARAYANA
 SHRI S. R. RAJAGOPAL (Alternate)
 SHRI N. C. SWARNKAR
 SHRI R. C. REDDY (Alternate)
 LT-COL M. P. THOMES
 SHRI O. P. PRUTHI (Alternate)
 SHRI B. N. THYAGARAJAN
 SHRI B. RAMAKRISHNA (Alternate)
 SHRI T. N. UBOVEJA
 SHRI E. UMMERKUTTY (Alternate)
 SHRI N. P. UPPAYADHAYA
 SHRI BHAJAN SINGH (Alternate)
 REPRESENTATIVE

Representing

Bharat Heavy Electricals Ltd (Electronic Division), Bangalore
 National Environmental Engineering Research Institute (CSIR), Nagpur
 Engineer-in-Chief's Branch, Ministry of Defence, New Delhi
 Bangalore Water Supply & Sewage Board, Bangalore
 Directorate General of Supplies and Disposals, New Delhi
 U. P. Instrument Ltd, Lucknow
 Public Health Engineering Department, Trivandrum

Bureau of Indian Standards

BIS is a statutory institution established under the *Bureau of Indian Standards Act, 1986* to promote harmonious development of the activities of standardization, marking and quality certification of goods and attending to connected matters in the country.

Copyright

BIS has the copyright of all its publications. No part of these publications may be reproduced in any form without the prior permission in writing of BIS. This does not preclude the free use, in the course of implementing the standard, of necessary details, such as symbols and sizes, type or grade designations. Enquiries relating to copyright be addressed to the Director (Publications), BIS.

Review of Indian Standards

Amendments are issued to standards as the need arises on the basis of comments. Standards are also reviewed periodically; a standard along with amendments is reaffirmed when such review indicates that no changes are needed; if the review indicates that changes are needed, it is taken up for revision. Users of Indian Standards should ascertain that they are in possession of the latest amendments or edition.

This Indian Standard has been developed from Doc No. CED 3 (4909).

Amendments Issued Since Publication

Amend No.	Date of Issue	Text Affected

BUREAU OF INDIAN STANDARDS

Headquarters:

Manak Bhavan, 9 Bahadur Shah Zafar Marg, New Delhi 110002
Telephones : 331 01 31, 331 13 75

Telegrams : Manaksanstha
(Common to all offices)

Regional Offices :

Telephone

Central : Manak Bhavan, 9 Bahadur Shah Zafar Marg
NEW DELHI 110002

{ 331 01 31
{ 331 13 75

Eastern : 1/14 C. I. T. Scheme VII M, V. I. P. Road, Maniktola
CALCUTTA 700054

{ 37 84 99, 37 85 61
{ 37 86 26, 37 86 62

Northern : SCO 335-336, Sector 34-A, CHANDIGARH 160022

{ 60 38 43
{ 60 20 25

Southern : C. I. T. Campus, IV Cross Road, MADRAS 600113

{ 235 02 16, 235 04 42
{ 235 15 19, 235 23 15

Western : Manakalaya, E9 MIDC, Marol, Andheri (East)
BOMBAY 400093

{ 632 92 95, 632 78 58
{ 632 78 91, 632 78 92

Branches : AHMADABAD. BANGALORE. BHOPAL. BHUBANESHWAR.
COIMBATORE. FARIDABAD. GHAZIABAD. GUWAHATI. HYDERABAD.
JAIPUR. KANPUR. LUCKNOW. PATNA. THIRUVANANTHAPURAM.

AMENDMENT NO. 1 NOVEMBER 1995
TO
IS 779 : 1994 WATER METERS (DOMESTIC TYPE) —
SPECIFICATION

(Sixth Revision)

(Page 1, clause 3.10) — Add the following sub-clauses after 3.10:

3.10.1 Single Jet Meter — In this meter the water arrives and impacts at a tangent to the turbine which is why the inlet and outlet connections of the meter are offset from the axis of the meter. The body works as the measuring chamber.

3.10.2 Multi Jet Meter — In this meter water arrives through a distribution box generally called impeller chamber which makes up the measurement chamber. This box has a number of holes, tangential to the turbine around its periphery which allows water to impact upon the turbine.'

(Page 2, clause 6.1, second para) — Substitute the following for the existing:

'Materials to be used in the manufacture of the body and component parts of water meters shall be as given in Annex B.'

(Page 2, sub-clause 6.1.1) — Delete.

(Page 2, clause 7.1, line 9) — Substitute 'shall' for 'should not'.

(Page 4, Table 2, col 4 and 5) — In col 4 insert 'a' and in col 5 insert 'b' at the end of the column headings.

(Page 5, clause 10.1, lines 4 and 5) — Substitute 'IS 6784 : 1995' for 'IS 6784 : 1984'.

(Page 5, clause 10.2, line 2) — Substitute 'IS 6784 : 1995' for 'IS 6784 : 1984'.

(Page 5, clause 10.3, line 2) — Substitute 'IS 6784 : 1995' for 'IS 6784 : 1984'.

(Page 5, clause 11.1, line 2) — Substitute 'IS 6784 : 1995' for 'IS 6784 : 1984'.

(Page 5, clause 11.2, line 4) — Substitute 'IS 6784 : 1995' for 'IS 6784 : 1984'.

(Page 7, sub-clause 12.4.4, line 2) — Substitute 'IS 6784 : 1995' for 'IS 6784 : 1984'.

(Page 7, clause 12.5, line 2) — Substitute 'IS 6784 : 1995' for 'IS 6784 : 1984'.

(Page 7, Annex A) — Substitute 'IS 2267 : 1995 Polystyrene moulding and extrusion materials (second revision)' for 'IS 2267 : 1972' and 'IS 6784 : 1995 Methods for performance testing of water meter (domestic type) (second revision)' for 'IS 6784 : 1984'.

(Page 8, Annex B) — Against 'Measuring chamber' add 'Plastics (High impact polystyrene conforming to IS 2267 : 1995 /ABS/Acetal co-polymer)'.

(Page 9, Annex B) — Against 'Dial' add 'Plastics (High impact polystyrene conforming to IS 2267 : 1995/Acrylic/Acetal co-polymer)'.

AMENDMENT NO. 2 JUNE 1996
TO
IS 779 : 1994 WATER METERS (DOMESTIC TYPE) —
SPECIFICATION

(Sixth Revision)

(See Amendment No. 1) — Wherever reference to 'IS 6784 : 1995' has been made it shall be read as 'IS 6784 : 1996'.

(CED 3)

Reprography Unit, BIS, New Delhi, India

AMENDMENT NO. 3 AUGUST 1999
TO
IS 779 : 1994 WATER METERS
(DOMESTIC TYPE) — SPECIFICATION

(*Sixth Revision*)

[*Foreword, para 3, item (c)*] — Substitute the following for the existing:

- 'c) Depending upon the metrological characteristics, Class A and Class B water meters have been introduced, based on ISO 4064 (Part 1) and EEC Council Directive.'

(*Page 1, clause 5*) — Substitute the following for the existing matter:

“Based on the maximum verification scale interval (see 8.3) and metrological characteristics (see 11), meters have been classified as Class ‘A’ and Class ‘B’.”

(*Page 3, clause 8.3*) — Substitute the following for the existing matter:

“Verification scale interval for Class ‘A’ and Class ‘B’ meters shall be as given in Table 1.

Table 1 Verification Scale Interval

Meter Size	Maximum Value of Verification Scale Interval, litres	
	Class A	Class B
15	0.2	0.2
20	0.5	0.2
25	1.0	0.5
40	2.0	1.0
50	2.0	2.0

(*Page 5, Table 3*) — Delete col 2 and col 5 along with their contents and renumber the columns accordingly.

(CED 3)