

IS : 6441 (Part VI) - 1973

Indian Standard

**METHODS OF TESTS FOR AUTOCLAVED
CELLULAR CONCRETE PRODUCTS**

**PART VI STRENGTH, DEFORMATION AND CRACKING OF
FLEXURAL MEMBERS SUBJECT TO BENDING-
SHORT DURATION LOADING TEST**

(Second Reprint DECEMBER 1983)

UDC 666.973.6:620.174



© Copyright 1973

INDIAN STANDARDS INSTITUTION
MANAK BHAVAN, 9 BAHADUR SHAH ZAFAR MARG
NEW DELHI 110002

*Indian Standard*METHODS OF TESTS FOR AUTOCLAVED
CELLULAR CONCRETE PRODUCTSPART VI STRENGTH, DEFORMATION AND CRACKING OF
FLEXURAL MEMBERS SUBJECT TO BENDING-
SHORT DURATION LOADING TEST

Cement and Concrete Sectional Committee, BDC 2

Chairman

DR H. C. VISVESVARAYA

Representing

Cement Research Institute of India, New Delhi

Members

DR A. S. BHADURI

National Test House, Calcutta

SHRI E. K. RAMACHANDRAN (*Alternate*)

SHRI A. K. CHATTERJI

Central Building Research Institute (CSIR),
RoorkeeDR S. S. REHSI (*Alternate*)

DIRECTOR

Central Road Research Institute (CSIR), New Delhi

DR R. K. GHOSH (*Alternate*)

DIRECTOR (CSMRS)

Central Water & Power Commission, New Delhi

DEPUTY DIRECTOR (CSMRS)

(*Alternate*)

SHRI K. H. GANGWAL

Hyderabad Asbestos Cement Products Ltd,
Hyderabad

SHRI K. C. GHOSAL

Alokudyog Services Ltd, New Delhi

SHRI A. K. BISWAS (*Alternate*)

DR R. K. GHOSH

Indian Roads Congress, New Delhi

DR R. R. HATTIANGADI

Associated Cement Companies Ltd, Bombay

SHRI P. J. JAGUS (*Alternate*)JOINT DIRECTOR, STANDARDS
(B & S)Research, Designs & Standards Organization,
LucknowDEPUTY DIRECTOR, STANDARDS
(B & S) (*Alternate*)

SHRI S. B. JOSHI

S. B. Joshi & Co Ltd, Bombay

SHRI M. T. KANSE

Directorate General of Supplies & Disposals

SHRI S. L. KATHURIA

Roads Wing, Ministry of Transport & Shipping

SHRI S. R. KULKARNI

M. N. Dastur & Co (Private) Ltd, Calcutta

SHRI M. A. MEHTA

Concrete Association of India, Bombay

SHRI O. MUTHACHEN

Central Public Works Department

SUPERINTENDING ENGINEER,
2ND CIRCLE (*Alternate*)*(Continued on page 2)*

© Copyright 1973

INDIAN STANDARDS INSTITUTION

This publication is protected under the *Indian Copyright Act (XIV of 1957)* and reproduction in whole or in part by any means except with written permission of the publisher shall be deemed to be an infringement of copyright under the said Act.

(Continued from page 1)

<i>Members</i>	<i>Representing</i>
SHRI ERACH A. NADIRSHAH SHRI K. K. NAMBIAR	Institution of Engineers (India), Calcutta In personal capacity (' Ramanalaya ', 11 First Crescent Park Road, Gandhinagar, Adyar, Madras) Engineer-in-Chief's Branch, Army Headquarters
BRIG NARESH PRASAD COL J. M. TOLANI (Alternate) PROF G. S. RAMASWAMY	Structural Engineering Research Centre (CSIR), Roorkee
DR N. S. BHAL (Alternate) DR A. V. R. RAO SHRI RAVINDER LAL (Alternate)	National Buildings Organization, New Delhi
SHRI G. S. M. RAO SHRI T. N. S. RAO SHRI S. R. PINHEIRO (Alternate)	Geological Survey of India, Nagpur Gammon India Ltd, Bombay
SECRETARY SHRI R. P. SHARMA SHRI MOHINDER SINGH (Alternate) SHRI G. B. SINGH SHRI C. L. KASLTWAL (Alternate)	Central Board of Irrigation & Power, New Delhi Irrigation and Power Research Institute, Amritsar Hindustan Housing Factory Ltd, New Delhi
SHRI J. S. SINGHOTA SHRI T. C. GARG (Alternate) SHRI R. K. SINHA SHRI K. A. SUBRAMANIAM SHRI P. S. RAMACHANDRAN (Alternate)	Beas Designs Organization, Nangal Township Indian Bureau of Mines, Nagpur India Cements Ltd, Madras
SHRI L. SWAROOP SHRI A. V. RAMANA (Alternate) SHRI D. AJITHA SIMHA, Director (Civ Engg)	Dalmia Cement (Bharat) Ltd, New Delhi Director General, ISI (Ex-officio Member)

Secretary

SHRI Y. R. TANEJA

Deputy Director (Civ Engg), ISI

Precast Concrete Products Subcommittee, BDC 2 : 9

Convener

SHRI M. A. MEHTA Concrete Association of India, Bombay

Members

SHRI E. T. ANTIA (Alternate to Shri M. A. Mehta) SHRI V. A. ARTHANOOOR SHRI T. RAMACHANDRAN (Alternate) SHRI H. B. CHATTERJEE SHRI S. K. CHATTERJEE DEPUTY DIRECTOR, STANDARDS (B & S) ASSISTANT DIRECTOR, STANDARDS (M/C) (Alternate) DIRECTOR (CSMRS) DEPUTY DIRECTOR (CSMRS) (Alternate)	Neyveli Lignite Corporation Ltd, Neyveli Hindustan Block Manufacturing Co Ltd, Calcutta Hindustan Housing Factory Ltd, New Delhi Research, Designs and Standards Organization, Lucknow Central Water & Power Commission, New Delhi
---	---

(Continued on page 7)

*Indian Standard***METHODS OF TESTS FOR AUTOCLAVED
CELLULAR CONCRETE PRODUCTS****PART VI STRENGTH, DEFORMATION AND CRACKING OF
FLEXURAL MEMBERS SUBJECT TO BENDING-
SHORT DURATION LOADING TEST****0. FOREWORD**

0.1 This Indian Standard (Part VI) was adopted by the Indian Standards Institution on 22 March 1973, after the draft finalized by the Cement and Concrete Sectional Committee had been approved by the Civil Engineering Division Council.

0.2 Autoclaved cellular concrete is a class of material, which has been developed commercially abroad and is in the process of development in this country also. A series of Indian Standards on cellular concrete is being formulated so as to provide guidance in obtaining reliable products in autoclaved cellular concrete. The Sectional Committee has considered it desirable to issue a standard for the methods of test for autoclaved cellular concrete products for the guidance of manufacturers and users.

0.3 In the formulation of this standard due weightage has been given to international co-ordination among the standards and practices prevailing in different countries in addition to relating it to the practices in the field in this country.

0.4 For convenience of reference, 'Indian Standard methods of test for autoclaved cellular concrete products' has been grouped into the following nine parts:

- Part I Determination of unit weight or bulk density and moisture content
- Part II Determination of drying shrinkage
- Part III Determination of thermal conductivity
- Part IV Corrosion protection of steel reinforcement in autoclaved cellular concrete
- Part V Determination of compressive strength
- Part VI Strength, deformation and cracking of flexural members subject to bending-short duration loading test

IS : 6441 (Part VI) - 1973

Part VII Strength, deformation and cracking of flexural members subject to bending-sustained loading test.

Part VIII Loading tests for flexural members in diagonal tension

Part IX Jointing of autoclaved cellular concrete elements

0.5 In reporting the result of a test or analysis made in accordance with this standard, if the final value, observed or calculated, is to be rounded off, it shall be done in accordance with IS : 2-1960*.

1. SCOPE

1.1 This standard (Part VI) covers the method of test for the strength, deformation and cracking (under short duration load) of flexural members such as floor or roof slabs of cellular concrete subject to bending.

2 TEST SPECIMEN

2.1 **Size of the Specimen** — The test specimen shall be the full size member as to be actually used in construction satisfying the requirements of the relevant Indian Standard (or the requirements specified by the manufacturer) in respect of shape and dimensions.

2.2 Condition of the Test Specimen

2.2.1 **Moisture Content** — The moisture content of the concrete during the test should be indicated and should be not less than 10 percent by weight, when determined in accordance with IS : 6441 (Part I)-1972†.

2.2.2 **Temperature of Specimen** — The temperature of the concrete shall not be materially different from the ambient temperature in which it is being tested and in any case not less than 0°C.

3. TEST ARRANGEMENTS

3.1 The member to be tested shall be simply supported at the ends. The supports shall consist of 25-mm thick horizontal mild steel plates bedded on rigid supports of steel or concrete. The ends of the member shall be fully in contact with the steel plate over the whole width of the member. The bearing width and the span used for the test shall be the same as those indicated by the manufacturer and to be actually used in construction practice (see Fig. 1).

*Rules for rounding off numerical values (*revised*).

†Methods of tests for autoclaved cellular concrete products: Part I Determination of unit weight or bulk density and moisture content.

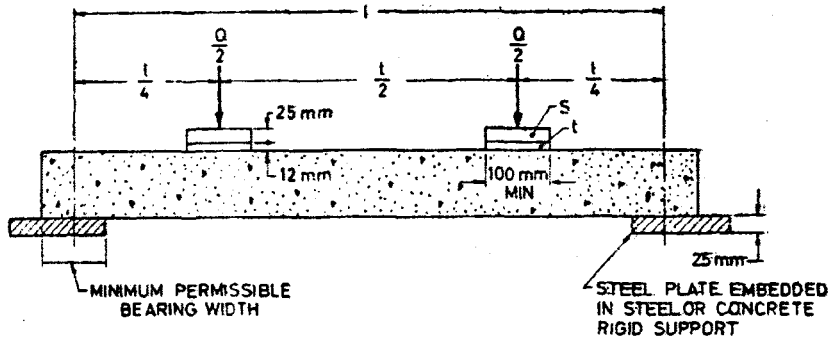

- l = effective span of unit,
 s = steel plate of thickness not less than 25 mm and length equal to width of the unit,
 t = porous fibre board thickness not less than 12 mm and length equal to width of the unit, and
 Q = applied load.

FIG. 1 METHOD FOR BENDING TEST OF REINFORCED CELLULAR CONCRETE UNITS (SHORT DURATION LOADING TEST)

4. LOADING

4.1 The test specimen member shall be subjected to loads placed at $\frac{1}{4}$ span points through steel platens not less than 25 mm thick, the load extending over the entire width of the member. The steel platens shall be bedded on soft fibre board packing, not less than 12 mm thick and of the same plan dimensions as the steel platens. The packing shall be placed between each steel loading platen and the top of the member. The span shall be taken as the distance between the centres of the bearing (see Fig. 1).

4.2 The loads at the two $\frac{1}{4}$ span points shall be equal and evenly distributed over the steel loading platens. The width of the steel platen shall not be less than 100 mm and shall be increased, where necessary, in multiples of 50 mm, so that the contact pressure under the applied load is not more than 20 percent of the compressive strength of the concrete.

4.3 The weight of the loading equipment shall be taken into account in calculating the applied load.

5. MEASUREMENTS

5.1 **Loads** — The loads shall be measured to an accuracy of not less than ± 1.5 percent of the applied load.

5.2 **Deflection** — The deflection of the member shall be measured at mid-span and the least count of the dial gauge shall be at least 0.01 mm.

5.3 Strain — Strain measurements may be made, where required, preferably at mid-span, on the main tension reinforcement and on the extreme compression fibre of the concrete.

5.4 Crack Widths — Crack widths shall be measured with an accuracy of ± 0.05 mm.

6. TEST PROCEDURE

6.1 Zero for the deflection measurements shall be taken immediately after the member had been placed in position.

6.2 The loading apparatus shall then be fixed and the load applied in stages. At the end of this stage the load, including the self weight of the member and the weight of the loading apparatus, shall be equal to the design dead load for the member.

6.2.1 After an interval of about 5 min loading shall be increased gradually until the load equals the combined dead and design live loads for the member.

6.2.2 After a further interval of about 5 min loading shall be increased gradually until the load equals the combined dead and twice the design live loads. At that load, the deflection shall be noted.

6.2.3 After a further interval of about 5 min loading shall be increased at a rate of about $\frac{1}{4}$ of the design live load per minute until failure occurs or the mid-span deflection is $\frac{1}{60}$ of the span, whichever is earlier. If the member is not tested to failure, then a hypothetical failure load shall be assumed to be that load for which the mid-span deflection is $\frac{1}{60}$ of the span.

6.2.4 Deflection and strain measurements (*see 5.3*) shall be recorded at the beginning and where applicable at the end of each of the loading stages; intermediate measurements may also be made if required.

7. REPORT

7.1 The test report shall state:

- a) moisture content of the specimen;
- b) temperature of the specimen; and
- c) measured loads, deflections, strains and crack widths for all load conditions.

(Continued from page 2)

<i>Members</i>	<i>Representing</i>
SHRI K. C. GHOSAL	Alokudyog Services Ltd, New Delhi
SHRI A. K. BISWAS (<i>Alternate</i>)	
SHRI V. G. GOKHALE	Bombay Chemicals Private Limited, Bombay
SHRI M. K. GUPTA	Himalayan Tiles & Marble Pvt Ltd, Bombay
SHRI B. D. JAYARAMAN	State Housing Board, Madras
SHRI B. K. JINDAL	Central Building Research Institute (CSIR), Roorkee
DR S. S. REHSI (<i>Alternate</i>)	
SHRI L. C. LAI	In personal capacity (<i>B/17 West End, New Delhi 23</i>)
SHRI G. C. MATHUR	National Buildings Organization, New Delhi
SHRI A. C. GUPTA (<i>Alternate</i>)	
SHRI S. NAHARAY	Engineering Construction Corporation Ltd, Madras
SHRI A. RAMAKRISHNA (<i>Alternate</i>)	
SHRI K. K. NAMBIAR	In personal capacity (<i>'Ramanalaya', 11 First Crescent Park Road, Gandhiagar, Adyar, Madras</i>)
SHRI RADHEY SHIAM	Engineer-in-Chief's Branch, Army Headquarters
SHRI B. G. SHIRKE	B. G. Shirke & Co, Poona
SHRI R. A. DESHMUKH (<i>Alternate</i>)	
SHRI C. N. SRINIVASAN	C. R. Narayana Road, Madras
SHRI C. N. RAGHAVENDRAN (<i>Alternate</i>)	
SURVEYOR OF WORKS (I)	Central Public Works Department
DR H. C. VISVESVARAYA	Cement Research Institute of India, New Delhi

INTERNATIONAL SYSTEM OF UNITS (SI UNITS)

Base Units

Quantity	Unit	Symbol
Length	metre	m
Mass	killogram	kg
Time	second	s
Electric current	ampere	A
Thermodynamic temperature	kelvin	K
Luminous intensity	candela	cd
Amount of substance	mole	mol

Supplementary Units

Quantity	Unit	Symbol
Plane angle	radian	rad
Solid angle	steradian	sr

Derived Units

Quantity	Unit	Symbol	Conversion
Force	newton	N	1 N = 1 kg. 1 m/s ²
Energy	joule	J	1 J = 1 N.m
Power	watt	W	1 W = 1 J/s
Flux	weber	Wb	1 Wb = 1 V.s
Flux density	tesla	T	1 T = 1 Wb/m ²
Frequency	hertz	Hz	1 Hz = 1 c/s (s ⁻¹)
Electric conductance	siemens	S	1 S = 1 A/V
Pressure, stress	pascal	Pa	1 Pa = 1 N/m ²

INDIAN STANDARDS INSTITUTION

Manak Bhavan, 9 Bahadur Shah Zafar Marg, NEW DELHI 110002

Telephones : 26 60 21, 27 01 31

Telegrams : Manaksanstha

Regional Offices:

		Telephone
Western : Novelty Chambers, Grant Road	BOMBAY 400007	37 97 29
Eastern : 5 Chowringhee Approach	CALCUTTA 700072	23-08 02
Southern : C. I. T. Campus, Adyar	MADRAS 600020	41 24 42

Branch Offices:

'Pushpak', Nurmohamed Shaikh Marg, Khanpur	AHMADABAD 380001	2 03 91
'F' Block, Unity Bldg, Narasimharaja Square	BANGALORE 560002	2 76 49
Gangotri Complex, Bhadbhada Road, T.T. Nagar	BHOPAL 462003	6 27 16
22E Kalpana Area	BHUBANESHWAR 751014	5 36 27
Ahimsa Bldg, SCO 82-83, Sector 17C	CHANDIGARH 160017	2 83 20
5-8-56C L. N. Gupta Marg	HYDERABAD 500001	22 10 83
D-277 Todarmal Marg, Banipark	JAIPUR 302006	6 98 32
117/418 B Sarvodaya Nagar	KANPUR 208005	8 12 72
Patilputra Industrial Estate	PATNA 800013	6 28 08
Hantex Bldg (2nd Floor), Rly Station Road	TRIVANDRUM 695001	32 27