

Indian Standard

CODE OF PRACTICE FOR
DETERMINATION OF BREAKING CAPACITY
OF SHALLOW FOUNDATIONS

(*First Revision*)

Sixth Reprint FEBRUARY 1998

UDC 624.151.5 : 624.131.52 : 006.76

© *Copyright* 1981

BUREAU OF INDIAN STANDARDS
MANAK BHAVAN, 9 BAHADUR SHAH ZAFAR MARG
NEW DELHI 110002

Indian Standard

CODE OF PRACTICE FOR DETERMINATION OF BREAKING CAPACITY OF SHALLOW FOUNDATIONS

(*First Revision*)

Foundation Engineering Sectional Committee, BDC 43

Chairman

PROF DINESH MOHAN

Representing

Central Building Research Institute (CSIR),
Roorkee

Members

DR R. K. BHANDARI

Central Building Research Institute (CSIR)
Roorkee

CHIEF ENGINEER

Calcutta Port Trust, Calcutta

SHRI S. GUHA (*Alternate*)

SHRI M. G. DANDAVATE

The Concrete Association of India, Bombay

SHRI N. C. DUGGAL (*Alternate*)

DR R. K. DAS GUPTA

Simplex Concrete Piles (India) Pvt Ltd, Calcutta

ADDITIONAL CHIEF ENGINEER (*Alternate*)

SHRI A. G. DASTIDAR

In personal capacity (5 Hungerford Road, 121 Hungerford Street, Calcutta)

SHRI V. C. DESHPANDE

The Pressure Piling Co (I) Pvt Ltd, Bombay

DIRECTOR (CSMRS)

Central Water Commission, New Delhi

DEPUTY DIRECTOR (CSMRS) (*Alternate*)

SHRI A. H. DIVANJI

Asia Foundations and Construction Co Pvt Ltd,
Bombay

SHRI A. N. JANGLE (*Alternate*)

DR JAGDISH NARAIN

Indian Geotechnic Society, New Delhi

PROF SWAMI SABAN (*Alternate*)

SHRI G. S. JAIN

G. S. Jain & Associates, Roorkee

SHRI ASHOK KUMAR JAIN (*Alternate*)

JOINT DIRECTOR (D)

National Buildings Organisation, New Delhi

SHRI SUNIL BERY (*Alternate*)

JOINT DIRECTOR RESEARCH

Ministry of Railways (RDSO)

(SM)

JOINT DIRECTOR RESEARCH (B & S) (*Alternate*)

(*Continued on page 2*)

© Copyright 1981

BUREAU OF INDIAN STANDARDS

This publication is protected under the *Indian Copyright Act* (XIV of 1957) and reproduction in whole or in part by any means except with written permission of the publisher shall be deemed to be an infringement of copyright under the said Act.

(Continued from page 1)

<i>Members</i>	<i>Representing</i>
DR R. K. KATTI	Indian Institute of Technology, Bombay
SHRI S. R. KULKARNI	M. N. Dastur & Co Pvt Ltd, Calcutta
SHRI S. ROY (<i>Alternate</i>)	
SHRI O. P. MALHOTRA	Public Works Department, Chandigarh Administration, Chandigarh
SHRI A. P. MATHUR	Central Warehousing Corporation, New Delhi
SHRI V. B. MATHUR	Machenzies Limited, Bombay
SHRI T. K. D. MUNSI	Engineers India Limited, New Delhi
SHRI M. IYENGAR (<i>Alternate</i>)	
BRIG OMBIR SINGH	Engineer-in-Chief's Branch, Army Headquarters, New Delhi
MAJ H. K. BHUTANI (<i>Alternate</i>)	
SHRI B. K. PANTHAKY	The Hindustan Construction Company Limited, Bombay
SHRI V. M. MADGE (<i>Alternate</i>)	
SHRI M. R. PUNJA	Cemindia Co Ltd, Bombay
SHRI S. MUKHERJEE (<i>Alternate</i>)	
SHRI N. E. V. RAGHVAN	The Braithwaite Burn & Jessop Construction Co Ltd, Calcutta
SHRI A. A. RAJU	Vijayanagar Steel Plant (Steel Authority of India), New Delhi
PROF GOPAL RANJAN	University of Roorkee, Roorkee
SHRI T. N. SUBBA RAO	Gammon India Limited, Bombay
SHRI S. A. REDDI (<i>Alternate</i>)	
SHRI Y. V. NARASIMHA RAO	Bokaro Steel Plant (Steel Authority of India), Bokaro
DR V. V. S. RAO	Nagadi Consultants Pvt Ltd, New Delhi
SHRI ARJUN RIJHSINGHANI	Cement Corporation of India, New Delhi
SHRI O. S. SRIVASTAVA (<i>Alternate</i>)	
DR A. SARGUNAN	College of Engineering, Guindy
SHRI S. BOOMINATHAN (<i>Alternate</i>)	
SHRI K. R. SAXENA	Public Works Department, Government of Andhra Pradesh, Hyderabad
DR S. P. SHRIVASTAVA	United Technical Consultants Pvt Ltd, New Delhi
DR R. KAPUR (<i>Alternate</i>)	
SHRI N. SIVAPURU	Ministry of Shipping and Transport, New Delhi
SHRI D. V. SIKKA (<i>Alternate</i>)	
SUPERINTENDING ENGINEER (DESIGNS)	Central Public Works Department, New Delhi
EXECUTIVE ENGINEER (DESIGNS) V (<i>Alternate</i>)	
SHRI M. D. TAMBEKAR	Bombay Port Trust, Bombay
DR A. VARADARAJAN	Indian Institute of Technology, New Delhi
DR R. KANIRAJ (<i>Alternate</i>)	
SHRI G. RAMAN, Director (Civ Engg)	Director General, ISI (<i>Ex-officio Member</i>)

Secretary

SHRI K. M. MATHUR
Deputy Director (Civ Engg), ISI

(Continued on page 16)

Indian Standard

CODE OF PRACTICE FOR DETERMINATION OF BREAKING CAPACITY OF SHALLOW FOUNDATIONS

(*First Revision*)

0. FOREWORD

0.1 This Indian Standard (First Revision) was adopted by the Indian Standards Institution on 30 January 1981, after the draft finalized by the Foundation Engineering Sectional Committee had been approved by the Civil Engineering Division Council.

0.2 The bearing capacity of foundations is needed for dimensioning the foundation for any structure. Several methods are available for the determination of bearing capacity of shallow foundations and this standard gives some of the methods which are commonly used for the purpose. Comparison of the results shows that when each of the various methods is applied to different problems no one method consistently gives higher or lower values of allowable bearing pressure. The designer must therefore regard the methods as aids to design which cannot replace the critical role of engineering judgement.

0.2.1 This standard was first published in 1971. The principal modifications made in this revision are: (a) keeping its terminology in line with that of other related Indian Standards, (b) giving generalized equations for calculation of ultimate bearing capacity, (c) including cone penetration methods and (d) deleting adjustment for fine sand and silt.

0.3 For the purpose of deciding whether a particular requirement of this standard is complied with, the final value, observed or calculated, expressing the result of a test or analysis, shall be rounded off in accordance with IS:2-1960*. The number of significant places retained in the rounded off value should be the same as that of the specified value in this standard.

*Rules for rounding off numerical values (revised).

1. SCOPE

1.1 This standard covers the procedure for determining the ultimate bearing capacity and allowable bearing pressure of shallow foundations based on shear and allowable settlement criteria.

2. TERMINOLOGY

2.0 For the purpose of this standard, the following definitions shall apply.

2.1 Terms Relating to Bearing Capacity

2.1.1 *Net Loading Intensity* — The net loading intensity on the foundation is the gross intensity of loading minus the weight of displaced soil above the foundation base.

2.1.2 *Ultimate Bearing Capacity* — The intensity of loading at the base of the foundation which would cause shear failure of the soil support.

2.1.3 *Safe Bearing Capacity* — Maximum intensity of loading that the foundation will safely carry without the risk of shear failure of soil irrespective of any settlement that may occur.

2.1.4 *Safe Bearing Pressure or Net Soil Pressure for Specified Settlement* — The intensity of loading that will cause a permissible settlement or specified settlement of the structure.

2.1.5 *Allowable Bearing Capacity* — The net intensity of loading which the foundation will carry without undergoing settlement in excess of the permissible value for the structure under consideration but not exceeding net safe bearing capacity.

2.2 General Terms

2.2.1 *Density Index (Relative Density)* — The ratio of the difference between the void ratios of cohesionless soil in the loosest state and any given state to the difference between its void ratios at the loosest and densest states.

2.2.2 *Effective Surcharge at the Base Level of Foundation* — The intensity of vertical pressure at the base level of foundation, computed assuming total unit weight for the portion of soil above the water table and submerged unit weight for the portion below the water table.

2.2.3 *Footing* — A structure constructed in brickwork, masonry or concrete under the base of a wall or column for the purpose of distributing the load over a larger area.

2.2.4 *Foundation* — That part of a structure which is in direct contact with soil and transmits loads into it.

2.2.5 Shallow Foundation — A foundation whose width is greater than its depth. The shearing resistance of the soil in the sides of the foundation is generally neglected.

3. SYMBOLS

3.1 For the purpose of this code and unless otherwise defined in the text, the following letter symbols shall have the meaning indicated against each:

- A = Area of footing in cm^2
- A' = Effective area of footing in cm^2
- B = Width of strip footing, width of footing, side of square footing, diameter of circular footing in cm
- B' = Effective width of footing in cm
- b = Half of B
- c = Cohesion in kgf/cm^2
- c_1 = Undrained cohesion of the top layer in kgf/cm^2
- c_2 = Undrained cohesion of the lower clay layer in kgf/cm^2
- D_f = Depth of foundation in cm
- D_w = Depth to water table in cm
- d = Depth of top clay layer with undrained cohesion c_1
- d_e, d_q, d_γ = Depth factors
- e = Eccentricity of loading in cm
- e_B = Eccentricity of loading along the width in cm
- e_L = Eccentricity of loading along the length in cm
- H = Horizontal component of loading in kgf
- i_e, i_q, i_γ = Inclination factors
- K_d = Depth factor (varies linearly from 1 for depth $D_f = 0$ to 1.33 for depth $D_f = B$)
- L = Length of footing in cm
- L' = Effective length of footing in cm
- N = Corrected standard penetration value
- $N_e, N'_e, N_q, N'_q, N_\gamma, N'_\gamma$ = Bearing capacity factors

$$N\phi = \tan^2 (\pi/4 + \phi/2)$$

q = Effective surcharge at the base level of foundation in kgf/cm^2

q_a = Net soil pressure for a specified settlement of 25 mm in kgf/cm^2

q_c = Static cone penetration resistance in kgf/cm^2

q_d = Net ultimate bearing capacity based on general shear failure in kgf/cm^2

q'_d = Net ultimate bearing capacity based on local shear failure in kgf/cm^2

R = Relative density of soil

W' = Correction factor for location of water table

s_e, s_q, s_γ = Shape factors

α = Inclination of the load to the vertical in degrees

ϕ = Angle of shearing resistance of soil in degrees

γ = Bulk unit weight of foundation soil kgf/cm^3

4. GENERAL

4.1 Sufficient number of undisturbed samples, about 40 to 100 mm in diameter or more or block samples should be obtained, where possible. These samples are for the determination of field density of soil and conducting tests for determining the relevant shear and consolidation parameters of the soil. Tests on soils should be conducted in accordance with relevant parts of IS : 2720*.

4.2 Position and fluctuation of water table should be ascertained. Reference may be made to IS : 1892-1979† and IS : 2132-1972‡ for guidance regarding investigations and collection of data.

5. ULTIMATE NET BEARING CAPACITY

5.0 General — Three types of failure of soil support beneath the foundations have been recognized, depending upon the deformations associated with the load and the extent of development of failure surface.

*Methods of test for soils.

†Code of practice for subsurface investigations for foundations (first revision).

‡Code of practice for thin-walled tube sampling of soils (first revision).

They are: a) general shear failure, b) local shear failure and c) punching shear. The choice of which method of analysis is best suited in a given situation is difficult to make, because only limited test data are available on full sized foundations to verify the reliability of the computed bearing capacity. However, guidelines given in relevant clauses may be used for guidance. Wherever possible bearing capacity calculations shall be made on the basis of shear strength parameters ϕ and c obtained from appropriate shear tests [see IS : 2720 (Parts XI and XIII)*] or from plate load test results as given in IS : 1888-1981† or from static cone penetration resistance q_c obtained from static cone penetration test as given in IS : 4968 (Part III)-1976‡.

5.0.1 Effect of Eccentricity

- a) *Single Eccentricity* — If the load has an eccentricity e , with respect to the centroid of the footing in only one direction, then the dimension of the footing in the direction of eccentricity shall be reduced by a length equal to $2e$. The modified dimension shall be used in the bearing capacity equation and in determining the effective area of the footing in resisting the load.
- b) *Double Eccentricity* — If the load has double eccentricity (e_L and e_B) with respect to the centroid of the footing then the effective dimensions of the footing to be used in determining the bearing capacity as well as in computing the effective area of the footing in resisting the load shall be determined as given below:

$$L' = L - 2 e_L$$

$$B' = B - 2 e_B$$

$$A' = L' \times B'$$

5.1 Soils with Cohesion and Angle of Shearing Resistance

5.1.1 The following formulae shall be used for calculating ultimate net bearing capacity in the case of strip footings:

a) In case of general shear failure $q_d = cN_c + q(N_q - 1) + \frac{1}{2}B\gamma N_\gamma$

b) In case of local shear failure $q'_d = \frac{1}{2}cN'_c + q(N'_q - 1) + \frac{1}{2}B\gamma N'_\gamma$

The values of N_c , N'_c , N_q , N'_q , N_γ and N'_γ may be obtained from Table 1.

* Methods of test for soils: Part XI Determination of shear strength parameters of a specimen tested in unconsolidated undrained triaxial compression without the measurement of pore water pressure, and Part XIII Direct shear test (first revision).

† Method of load test on soils (second revision).

‡ Method for subsurface sounding for soils: Part III Static cone penetration test (first revision).

TABLE 1 BEARING CAPACITY FACTORS

(Clause 5.1.1)

BEARING CAPACITY FACTORS			
ϕ (Degrees)	N_c	N_q	N_γ
0	5.14	1.00	0.00
5	6.49	1.57	0.45
10	8.35	2.47	1.22
15	10.98	3.94	2.65
20	14.83	6.40	5.39
25	20.72	10.66	10.88
30	30.14	18.40	22.40
35	46.12	33.30	48.03
40	75.31	64.20	109.41
45	138.88	134.88	271.76
50	266.89	319.07	762.89

NOTE — For obtaining values of N'_c , N'_q and N'_γ , calculate $\phi' = \tan^{-1}(0.67 \tan \phi)$. Read N_c , N_q , and N_γ from the Table corresponding to the value of ϕ' instead of ϕ which are values of N'_c , N'_q , N'_γ respectively.

5.1.2 The ultimate net bearing capacity obtained in 5.1.1 for strip footing shall be modified to take into account, the shape of the footing, inclination of loading, depth of embedment and effect of water table. The modified bearing capacity formulæ are given as under:

- a) In case of general shear failure q_u }
$$= cN_c s_{cd}e_{ic} + q(N_q - 1) s_{qd}q_{ia} + \frac{1}{2} B\gamma N_\gamma s_\gamma d_{iy} W'$$
- b) In case of local shear failure q'_u }
$$= \frac{2}{3} cN'_c s_{cd}e_{ic} + q(N'_q - 1) s_{qd}q_{ia} + \frac{1}{2} B\gamma N'_\gamma s_\gamma d_{iy} W'$$

5.1.2.1 The shape factors shall be as given in Table 2.

TABLE 2 SHAPE FACTORS

SL No.	SHAPE OF BASE	SHAPE FACTOR		
		s_c	s_q	s_γ
i)	Continuous strip	1.00	1.00	1.00
ii)	Rectangle	$1+0.2 B/L$	$1+0.2 B/L$	$1-0.4 B/L$
iii)	Square	1.3	1.2	0.8
iv)	Circle	1.3	1.2	0.6

Use B as the diameter in the bearing capacity formula.

5.1.2.2 The depth factors shall be as under:

$$d_c = 1 + 0.2 D_f/B \sqrt{N\phi}$$

$$d_q = d_\gamma = 1 \text{ for } \phi < 10^\circ$$

$$d_q = d_\gamma = 1 + 0.1 D_f/B \sqrt{N\phi} \text{ for } \phi > 10^\circ$$

NOTE — The correction is to be applied only when back filling is done with proper compaction.

5.1.2.3 The inclination factor shall be as under:

$$i_c = i_q = \left(1 - \frac{\alpha}{90} \right)^2$$

$$i_\gamma = \left(1 - \frac{\alpha}{\phi} \right)^2$$

5.1.2.4 *Effect of water table*

- If the water table is likely to permanently remain at or below a depth of $(D_f + B)$ beneath the ground level surrounding the footing then $W' = 1$.
- If the water table is located at a depth D_f or likely to rise to the base of the footing or above then the value of W' shall be taken as 0.5.
- If the water table is likely to permanently get located at depth $D_f < D_w < (D_f + B)$, then the value of W' be obtained by linear interpolation.

5.2 **Cohesionless Soil ($c = 0$)** — The ultimate net bearing capacity shall be calculated as given in 5.2.1 and 5.2.2.

5.2.1 *Based on Relative Density* — The formulæ given in 5.1.1 and 5.1.2 shall be used, together with relevant shear strength parameter.

5.2.1.1 The relative density as given in Table 3 shall be used as a guide to determine the method of analysis.

TABLE 3 METHOD OF ANALYSIS BASED ON RELATIVE DENSITY

Sl. No.	RELATIVE DENSITY (DENSITY INDEX)	VOID RATIO	CONDITION	METHOD OF ANALYSIS
i)	Greater than 70 percent	Less than 0.55	Dense	General shear
ii)	Less than 20 percent	Greater than 0.75	Loose	Local shear (as well as punching shear)
iii)	20 to 70 percent	0.55 to 0.75	Medium	Interpolate between i) and ii)

5.2.2 Based on Standard Penetration Resistance Value — The standard penetration resistance shall be determined as per IS : 2131-1981* at a number of selected points at intervals of 75 cm in the vertical direction or change of strata if it takes place earlier and the average value beneath each point shall be determined between the level of the base of the footing and the depth equal to 1.5 to 2 times the width of foundation. In computing the average any individual value more than 50 percent greater than the average shall be neglected, but the values for all loose seams shall be included.

5.2.2.1 The ultimate net bearing capacity shall be calculated from following formula (covering effect of other factors as mentioned in 5.1.2):

$$q_u = q(N_q - 1) s_q d_q i_q + \frac{1}{2} B \gamma N_{\gamma} s_{\gamma} d_{\gamma} i_{\gamma} W'$$

Where ϕ may be read from Fig. 1, N_{γ} , N_q may be read from Table 1, s_q , d_q , i_q , s_{γ} , d_{γ} , i_{γ} , and W' may be obtained as in 5.1.

5.2.3 Method Based on Static Cone Penetration Test — The static cone point resistance ' q_c ' shall be determined as per IS : 4968 (Part III)-1976† at number of selected points at intervals of 10 to 15 cm. The observed values shall be corrected for the dead weight of sounding rods. Then the average value at each one of the location shall be determined between the level of the base of the footing and the depth equal to $1\frac{1}{2}$ to 2 times the width of the footing. The average of the static cone point resistance values shall be determined for each one of the location and minimum of the average values shall be used in the design. The ultimate bearing capacity of shallow strip footings on cohesionless soil deposits shall be determined from Fig. 2.

5.3 Cohesive Soil (when $\phi = 0$)

5.3.1 Homogeneous Layer

5.3.1.1 The net ultimate bearing capacity immediately after construction on fairly saturated homogeneous cohesive soils shall be calculated from following formula:

$$q_u = c N_c s_c d_c i_c$$

where

$$N_c = 5.14.$$

* Method for standard penetration test for soils (first revision).

† Method for subsurface sounding for soils: Part III Static cone penetration test (first revision).

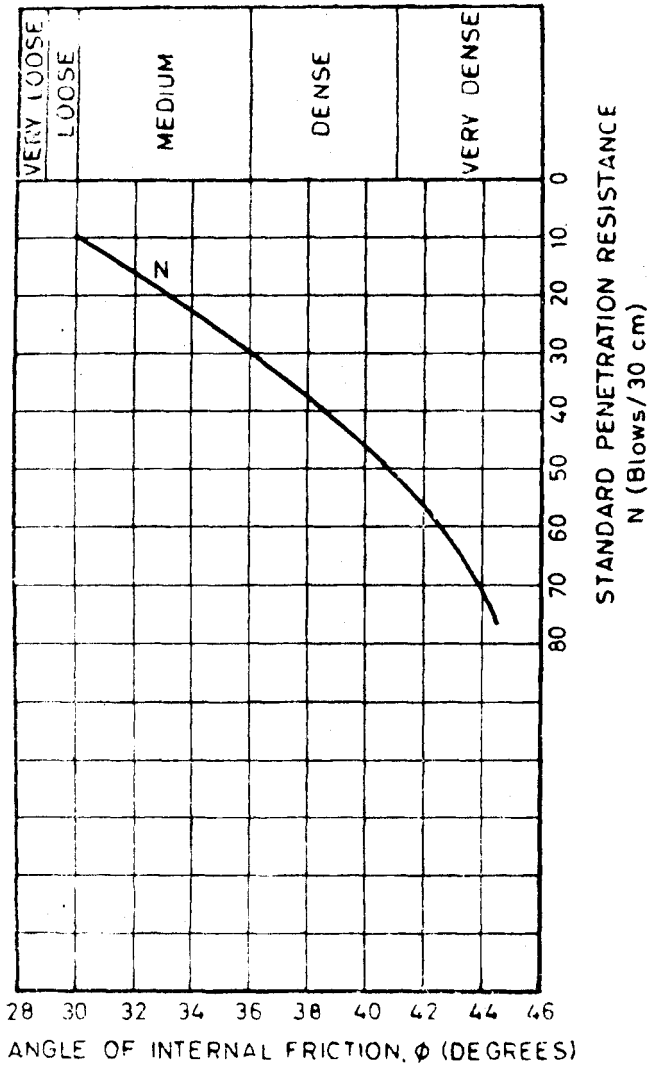

FIG. 1 RELATIONSHIP BETWEEN ϕ AND N

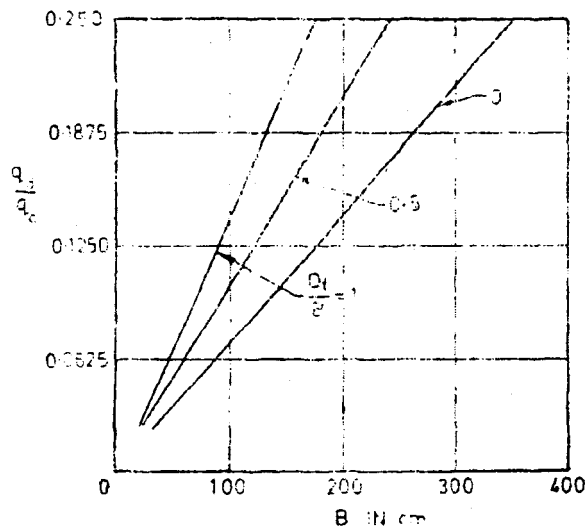

FIG. 2 CHART FOR STATIC CONE TEST

The value of c shall be obtained from unconfined compressive strength test. Alternatively, it can also be derived from static cone test (see 5.3.1.2). The values of s_c , d_c and i_c may be obtained as in 5.1 If the shear strength for a depth of $\frac{1}{2}B$ beneath the foundation does not depart from the average by more than 50 percent, the average may be used in the calculation.

5.3.1.2 Alternately, cohesion c shall be determined from the static cone point resistance q_c using the empirical relationship shown below:

Soil Type	Point Resistance Values (q_c) kgf/cm^2 ,	Range of Undrained Cohesion (kgf/cm^2)
Normally consolidated clays	$q_c < 20$	$q_c/18$ to $q_c/15$
Over consolidated clays	$q_c > 20$	$\frac{q_c}{26}$ } to { $\frac{q_c}{22}$

5.3.2 Two Layered System — In the case of two layered cohesive soil system which do not exhibit marked anisotropy the ultimate net bearing capacity of a strip footing can be calculated by using the formula given below:

$$q_u = c_1 N_c$$

where N_c may be obtained from Fig. 3.

5.3.3 Desiccated Soil — In the case of desiccated cohesive soils, the undrained cohesion is likely to decrease along with depth and is likely to get stabilized at some depth below ground level, usually 3.5 m, if other factors do not influence. If a plot of undrained cohesion, values as shown in Fig. 4 is obtained, and where the pressure bulb falls within the desiccated top soil the ultimate net bearing capacity shall be obtained from Table 4.

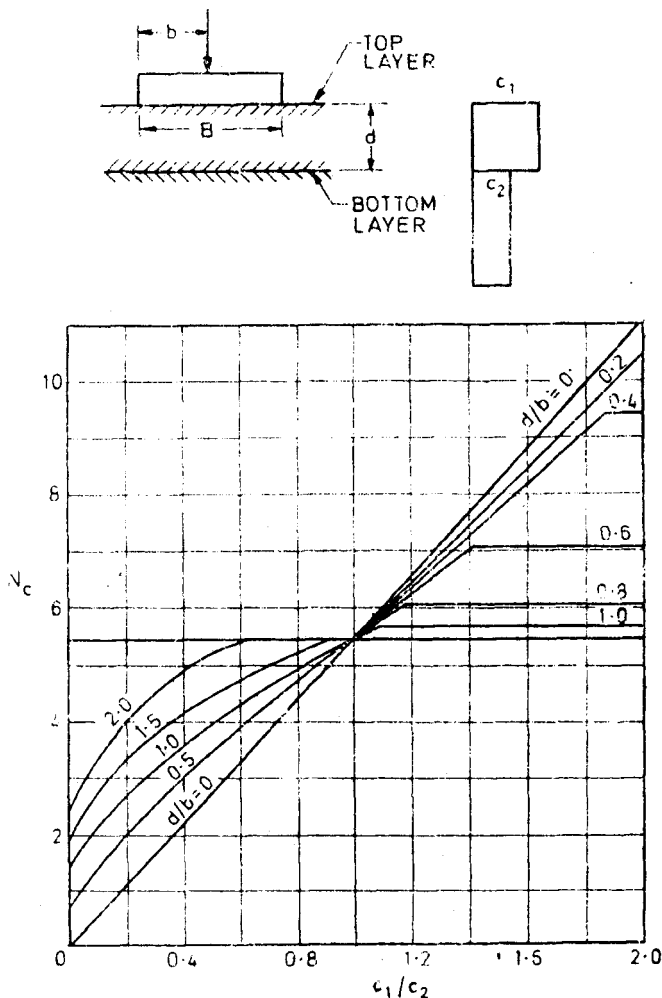

FIG. 3 BEARING CAPACITY FACTORS FOR LAYERED COHESIVE SOIL DEPOSITS

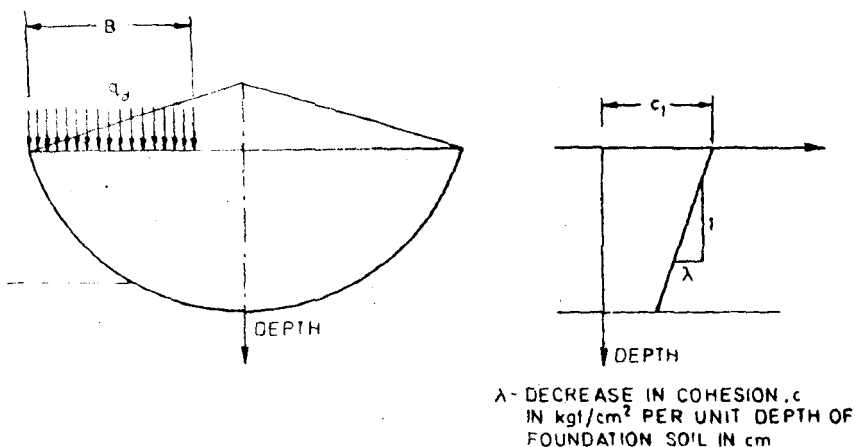

FIG. 4 BEARING CAPACITY FACTORS FOR DESICCATED COHESIVE SOIL

TABLE 4 DATA FOR DETERMINING ULTIMATE NET BEARING CAPACITY

$\frac{8\lambda B}{q_d}$	$\frac{q_d}{c_1}$
0.0	5.7
0.2	5.0
0.4	4.5
0.6	4.0
0.8	3.6
1.0	3.2

λ , c_1 shall be obtained from the borehole data, and for a known value of the width of the strip footing 'B', by trial and error q_d can be estimated by matching $\frac{8\lambda B}{q_d}$ with $\frac{q_d}{c_1}$.

6. ALLOWABLE BEARING CAPACITY

6.1 The allowable bearing capacity shall be taken as either of the following, whichever is less:

- Net ultimate bearing capacity as obtained in 5 divided by suitable factor of safety, that is, net safe bearing capacity.

- b) The net soil pressure (*see* 6.1.1) that can be imposed on the base without the settlement exceeding the permissible values as given in IS : 1904-1978* to be determined for each structure and type of soil, that is, safe bearing pressure.

6.1.1 Safe Bearing Pressure — The permissible settlements for different types of soil formations are specified in IS : 1904-1978*. The methods for calculations of settlements for assumed pressure are specified in IS : 8009 (Part I)-1976†; by calculating the settlements for two or three probable soil pressures and interpolating, the net soil pressure for permissible settlement may be estimated.

*Code of practice for structural safety of buildings: Shallow foundation (*second revision*).

†Code of practice for calculation of foundations: Part I Shallow foundations subjected to symmetrical static vertical loads.

(Continued from page 2)

Bearing Capacity of Foundation Subcommittee, BDC 43 : 4

<i>Convener</i>	<i>Representing</i>
SRI S. GUHA	Calcutta Port Trust, Calcutta
<i>Members</i>	
DEPUTY DIRECTOR STANDARDS (R & S), CBI, RDSO	Ministry of Railways
EXECUTIVE ENGINEER (DESIGNS) V	Central Public Works Department, New Delhi
SRI T. N. MUKHERJEE	Martin & Burns Co Ltd, Calcutta
SRI B. G. RAO	Central Building Research Institute (CSIR), Roorkee
SRI AMAR SINGH (<i>Alternate</i>)	
DR SWAMI SARAN	University of Roorkee, Roorkee
SRI K. R. SAXENA	Engineering Research Laboratory, Hyderabad
SRI O. S. SRIVASTAVA	Cement Corporation of India, New Delhi
SRI S. K. CHATTERJEE (<i>Alternate</i>)	

BUREAU OF INDIAN STANDARDS

Headquarters:

Manak Bhavan, 9 Bahadur Shah Zafar Marg, NEW DELHI 110002

Telephones: 323 0131, 323 3375, 323 9402

Fax : 91 11 3234062, 91 11 3239399, 91 11 3239382

Telegrams : Manaksanstha
(Common to all Offices)

Central Laboratory:

Plot No. 20/9, Site IV, Sahibabad Industrial Area, SAHIBABAD 201010 Telephone
8-77 00 32

Regional Offices:

Central : Manak Bhavan, 9 Bahadur Shah Zafar Marg, NEW DELHI 110002 323 76 17

*Eastern : 1/14 CIT Scheme VII M, V.I.P. Road, Maniktola, CALCUTTA 700054 337 86 62

Northern : SCO 335-336, Sector 34-A, CHANDIGARH 160022 60 38 43

Southern : C.I.T. Campus, IV Cross Road, CHENNAI 600113 235 23 15

†Western : Manakalaya, E9 Behind Marol Telephone Exchange, Andheri (East),
MUMBAI 400093 832 92 95

Branch Offices:

'Pushpak', Nurmohamed Shaikh Marg, Khanpur, AHMEDABAD 380001 550 13 48

‡Peenya Industrial Area, 1st Stage, Bangalore - Tumkur Road,
BANGALORE 560058 839 49 55

Gangotri Complex, 5th Floor, Bhadbhada Road, T. T. Nagar, BHOPAL 462003 55 40 21

Plot No. 62-63, Unit VI, Ganga Nagar, BHUBANESHWAR 751001 40 36 27

Kalaikathir Buildings, 670 Avinashi Road, COIMBATORE 641037 21 01 41

Plot No. 43, Sector 16 A, Mathura Road, FARIDABAD 121001 8-28 88 01

Savitri Complex, 116 G. T. Road, GHAZIABAD 201001 8-71 19 96

53/5 Ward No. 29, R. G. Barua Road, 5th By-lane, GUWAHATI 781003 54 11 37

5-8-58C, L. N. Gupta Marg, Nampally Station Road, HYDERABAD 500001 20 10 83

E-52, Chitaranjan Marg, C-Scheme, JAIPUR 302001 37 29 25

117/418 B, Sarvodaya Nagar, KANPUR 208005 21 68 76

Seth Bhawan, 2nd Floor, Behind Leela Cinema, Naval Kishore Road,
LUCKNOW 226001 23 89 23

Patliputra Industrial Estate, PATNA 800013 26 23 05

T. C. No. 14/1421, University P. O. Palayam,
THIRUVANANTHAPURAM 695034 6 21 17

NIT Building, Second Floor, Gokulpat Market, NAGPUR 440010 52 51 71

Institution of Engineers (India) Building, 1332 Shivaji Nagar, PUNE 411005 32 36 35

*Sales Office is at 5 Chowringhee Approach, P. O. Princep Street,
CALCUTTA 700072 27 10 85

†Sales Office is at Novelty Chambers, Grant Road, MUMBAI 400007 309 65 28

‡Sales Office is at 'F' Block, Unity Building, Narashimaraja Square,
BANGALORE 560002 222 39 71

TO

IS:6403-1981 CODE OF PRACTICE FOR DETERMINATION
OF BEARING CAPACITY OF SHALLOW FOUNDATIONS

(First Revision)

Alterations

(Page 10, clause 5.2.2, last sentence)

Substitute the following for the existing sentence:

'In computing the value, any individual value more than 50 percent of the average calculated shall be neglected and average re-calculated (the values for all loose seams shall however be included).'

(Page 13, clause 5.3.3):

- a) Line 3 - Substitute 'around' for 'usually'
- b) Line 6 - Add the words 'with the assumption of cylindrical failure surface' after 'obtained'

(Page 13, Fig. 3) - Substitute ' c_2/c_1 ' for ' c_1/c_2 '.

(Page 14, Fig. 4, caption) - Substitute the following for the existing caption:

'Decreasing Cohesion with Depth in Case of Desiccated Cohesive Soil'

(Page 14, Table 4 and clause 5.3.3) - Substitute

$\frac{4 \lambda B}{q_d}$ for $\frac{8 \lambda B}{q_d}$

(Page 15, clause 6.1.1, line 3) - Add the words 'from standard penetration resistance' after 'pressure'.

(Page 15, clause 6.1.1) - Add the following sentence in the end:

'This safe bearing pressure can also be calculated based on plate load test (see IS:1888-1982⁵).'

(Page 15, foot-note with '+' mark) - Add the words 'of settlement' after 'calculation'.

(Page 15, foot-note) - Add the following additional foot-note:

'⁵Method of load test on soils (second revision)'.

(BDC 43)