

Indian Standard

METHOD OF TEST FOR DETERMINING
AGGREGATES IMPACT VALUE OF SOFT
COARSE AGGREGATES

(Fourth Reprint AUGUST 1991)

UDC 691.322:620.178.7

© Copyright 1970

BUREAU OF INDIAN STANDARDS
MANAK BHAVAN, 9 BHADUR SHAH ZAFAR MARG
NEW DELHI 110002

Indian Standard

METHOD OF TEST FOR DETERMINING AGGREGATES IMPACT VALUE OF SOFT COARSE AGGREGATES

Stones Sectional Committee, BDC 6

Chairman

SHRI O. MUTHACHEN

Representing

Central Public Works Department, New Delhi

Members

SHRI K. K. AGRAWALA	Builders' Association of India, Bombay
SHRI K. K. MADHOK (<i>Alternate</i>)	
SHRI T. N. BHARGAVA	Ministry of Shipping & Transport (Roads Wing)
CHIEF ARCHITECT	Central Public Works Department, New Delhi
SHRI G. C. DAS	National Test House, Calcutta
DR M. P. DHIR	Central Road Research Institute (CSIR), New Delhi
SHRI R. L. NANDA (<i>Alternate</i>)	
SHRI M. K. GUPTA	Himalayan Tiles and Marble Pvt Ltd, Bombay
SHRI H. D. GUPTA	Public Works Department, Government of Rajasthan
DR IQBAL ALI	Engineering Research Laboratory, Government of Andhra Pradesh
SHRI A. B. LINGAM (<i>Alternate</i>)	
SHRI JACOB THOMAS	Public Works Department, Government of Kerala
SHRI V. S. KAMAT	The Hindustan Construction Co Ltd, Bombay
SHRI V. S. KRISUNASWAMY	Geological Survey of India
SHRI T. R. MEHANDRU	Institution of Engineers (India), Calcutta
SHRI G. S. MEHROTRA	Central Building Research Institute (CSIR), Roorkee
SHRI K. H. PARIKH	Associated Stone Industries (Kotah) Ltd, Ramganj- mandi (Rajasthan)
SHRI J. S. SHAH (<i>Alternate</i>)	
SHRI PREM SWARUP	Department of Geology & Mining, Government of Uttar Pradesh
SHRI A. K. AGARWAL (<i>Alternate</i>)	
SHRI RABINDER SINGH	National Buildings Organization, New Delhi
DR A. V. R. RAO (<i>Alternate</i>)	
SHRI H. SEETHARAMAIAH	Public Works Department, Government of Mysore
SHRI M. L. SETHI	Public Works Department, Government of Mysore
SHRI Y. N. DAVE (<i>Alternate</i>)	
SUPERINTENDING ENGINEER	Public Works Department, Government of Tamil Nadu
(DESIGN AND MARINE WORKS)	
DEPUTY CHIEF ENGINEER	
(I & D) (<i>Alternate</i>)	

(Continued on page 6)

BUREAU OF INDIAN STANDARDS
MANAK BHAVAN, 9 RAHADUR SHAH ZAFAR MARG
NEW DELHI 110002

Indian Standard

METHOD OF TEST FOR DETERMINING AGGREGATES IMPACT VALUE OF SOFT COARSE AGGREGATES

0. FOREWORD

0.1 This Indian Standard was adopted by the Indian Standards Institution on 15 May 1970, after the draft finalized by the Stones Sectional Committee had been approved by the Civil Engineering Division Council.

0.2 The road system in the country is developing at a fast rate in order to meet the needs of expanding economy. In view of large scale construction programme and for effecting economy in the cost of construction, soft aggregates having adequate mechanical strength in terms of impact value may be made use of in the bases and sub-bases of road pavements. As majority of soft aggregates, such as laterite, kankar, shale, etc, lose their strength on wetting, the standard procedure [see IS : 2386 (Part IV)-1963*] has been modified by the Central Road Research Institute, New Delhi, so as to determine the impact value of such aggregates under saturated condition.

NOTE — This method of test for aggregate impact value may also be equally applied to brick aggregates.

0.3 In the formulation of this standard assistance has been derived from Road Research Monograph No: 5 issued by Central Road Research Institute, New Delhi.

0.4 In reporting the results of a test or analysis made in accordance with this standard, if the final value, observed or calculated, is to be rounded off, it shall be done in accordance with IS : 2-1960†.

1. SCOPE

1.1 This standard covers the procedure for determining the aggregates impact value of soft coarse aggregate used for bases and sub-bases of road pavements.

2. APPARATUS

2.0 The apparatus shall consist of the following:

*Methods of test for aggregates for concrete: Part IV Mechanical properties.

†Rules for rounding off numerical values (revised).

2.1 The impact testing machine of the general form shown in Fig. 1 and complying with the following:

- a) Total weight not more than 60 kg nor less than 45 kg.
- b) The machine shall have a metal base weighing between 22 and 30 kg with a plane lower surface of not less than 30 cm diameter, and shall be supported on a level and plane concrete or stone block or floor at least 45 cm thick. The machine shall be prevented from rocking either by fixing it to the block or floor or by supporting it on a level and plane metal plate cast into the surface of the block or floor.
- c) A cylindrical steel cup of the following internal dimensions and not less than 6.3 mm thick with its inner surface case-hardened, that can be rigidly fastened at the centre of the base and easily removed for emptying:

Diameter	102 mm
Depth	50 mm

- d) A metal tup or hammer weighing 13.5 to 14.0 kg, the lower end of which shall be cylindrical in shape, 100 mm in diameter and 50 mm long, with a 2-mm chamfer at the lower edge, and case-hardened. The hammer shall slide freely between vertical guides so arranged that the lower (cylindrical) part of the hammer is above and concentric with the cup.
- e) Means for raising the hammer and allowing it to fall freely between the vertical guides from a height of 380 ± 5.0 mm on to the test sample in the cup, and means for adjusting the height of fall within 5 mm.
- f) Means for supporting the hammer whilst fastening or removing the cup.

NOTE — Some means for automatically recording the number of blows is desirable.

2.2 Sieves — IS Sieves of sizes 12.5 mm, 10 mm and 2.36 mm.

2.3 Measure — a cylindrical metal measure, tared to the nearest gram, of sufficient rigidity to retain its form under rough usage, and of the following internal dimensions:

Diameter	75 mm
Depth	50 mm

2.4 Tamping Rod — a straight metal tamping rod of circular cross-section 10 mm in diameter and 230 mm long, rounded at one end.

IS: 5640 - 1970

2.5 Balance— capacity not less than 500 g, readable and accurate to 0.1 g.

2.6 Oven— a well-ventilated oven, thermostatically controlled to maintain a temperature of 100 to 110°C.

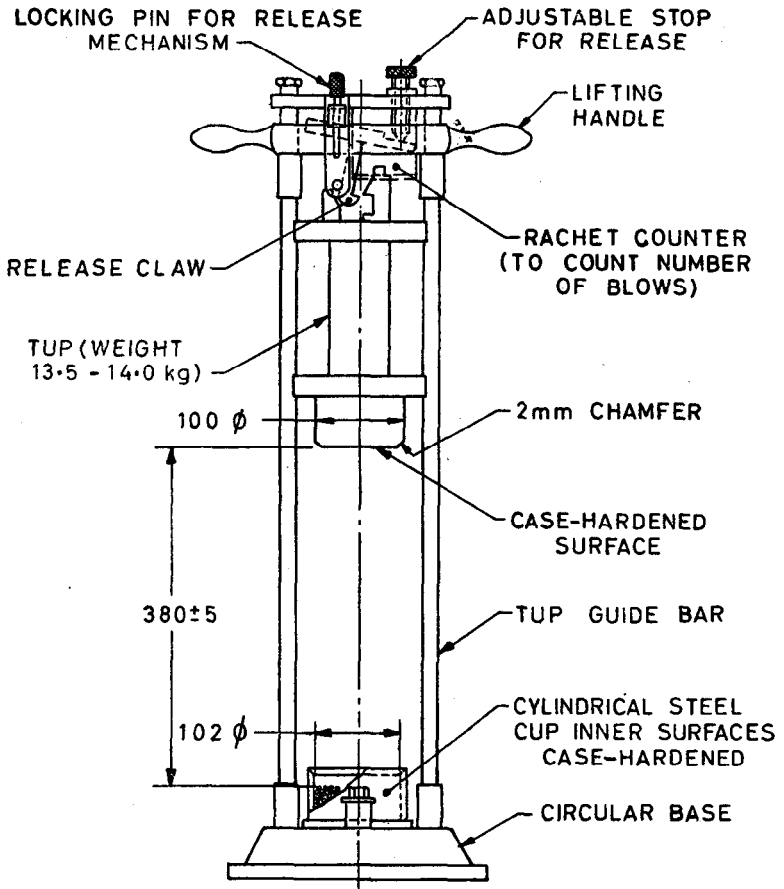

All dimensions in millimetres

FIG. 1 IMPACT TESTING MACHINE

3. PREPARATION OF TEST SAMPLE

3.1 The test sample shall consist of aggregate the whole of which passes a 12.5-mm IS Sieve and is retained on a 10-mm IS Sieve. The aggregate comprising the test sample shall be dried in an oven for a period of four hours till the time, the weight becomes constant at a temperature of 105 to 110°C and cooled.

3.2 The measure shall be filled about one-third full with the aggregate and tamped with 25 strokes of the rounded end of the tamping rod. A further similar quantity of aggregate shall be added and a further tamping of 25 strokes given. The measure shall finally be filled to overflowing, tamped 25 times and the surplus aggregate struck off, using the tamping rod as a straight-edge. The net weight of aggregate in the measure shall be determined to the nearest gram (weight *A*) and this weight of aggregate shall be used for the duplicate test on the same material.

3.3 This oven-dried sample is immersed in water for three days.

3.4 Wet sample after the immersion period is surface dried by suitable cloth.

4. TEST PROCEDURE

4.1 The impact machine shall rest without wedging or packing upon the level plate, block or floor, so that it is rigid and the hammer guide columns are vertical.

4.2 The cup shall be fixed firmly in position on the base of the machine and the whole of the test sample placed in it and compacted by a single tamping of 25 strokes of the tamping rod.

4.3 The hammer shall be raised until its lower face is 380 mm above the upper surface of the aggregate in the cup, and allowed to fall freely on to the aggregate. The test sample shall be subjected to a total of 15 such blows each being delivered at an interval of not less than one second.

4.4 The crushed aggregate shall then be removed from the cup and the whole of it sieved on the 2.36-mm IS Sieve and washed with water till no further significant amount passes in one minute. The fraction retained on the sieve shall be dried in an oven to the constant weight at 105 to 110°C and weighed to an accuracy of 0.1 g (weight *B*). The fraction retained on the sieve (weight *B*) shall be subtracted from the weight of the original oven-dried sample (weight *A*). The resultant weight (weight *A* - weight *B*) shall represent the fraction passing 2.36-mm IS Sieve (weight *C*). Two tests shall be made.

5. CALCULATIONS

5.1 The ratio of the weights of the fines formed to the total sample in each test shall be expressed as percentage of the oven dried, the result being recorded to the first decimal place:

$$\text{Aggregate impact value} = \frac{C}{A} \times 100$$

where

C = weight of the fines formed, and

A = weight of the oven-dried sample.

6. REPORTING OF RESULTS

6.1 The mean of the two results shall be reported as aggregate impact value (wet) of the tested material.

(Continued from page 1)

Members

SHRI S. V. SURYANARIANA
SHRI M. V. YOGI

SHRI K. N. SUBHA RAO (*Alternate*)
SHRI R. NAGARAJAN,
Director (Civ Engg)

Representing

Central Water & Power Commission, New Delhi
Engineer-in-Chief's Branch, Army Headquarters
(Ministry of Defence)

Director General, ISI (*Ex-officio Member*)

Secretary

SHRI K. M. MATHUR
Assistant Director (Civ Engg), ISI

BUREAU OF INDIAN STANDARDS

Headquarters:

Manak Bhavan, 9 Bahadur Shah Zafar Marg, NEW DELHI 110002

Telephones: 331 01 31, 331 13 75

Telegrams: Manaksanstha
(Common to all Offices)

Regional Offices:

	Telephone
Central : Manak Bhavan, 9 Bahadur Shah Zafar Marg, NEW DELHI 110002	{ 331 01 31 331 13 75
*Eastern : 1/14 C. I. T. Scheme VII M, V. I. P. Road, Maniktola, CALCUTTA 700054	36 24 99
Northern : SCO 445-446, Sector 35-C, CHANDIGARH 160036	{ 2 18 43 3 16 41
Southern : C. I. T. Campus, MADRAS 600113	{ 41 24 42 41 25 19 41 29 16
†Western : Manakalaya, E9 MIDC, Marol, Andheri (East), BOMBAY 400093	6 32 92 95

Branch Offices:

*Pushpak', Nurmohamed Shaikh Marg, Khanpur, AHMADABAD 380001	{ 2 63 48 2 63 49
‡Peenya Industrial Area 1st Stage, Bangalore Tumkur Road BANGALORE 560058	{ 38 49 55 38 49 56
Gangotri Complex, 5th Floor, Bhadbhada Road, T. T. Nagar, BHOPAL 462003	6 67 16
Plot No. 82/83, Lewis Road, BHUBANESHWAR 751002	5 36 27
53/5, Ward No. 29, R.G. Barua Road, 5th Byelane, GUWAHATI 781003	3 31 77
5-8-56C L. N. Gupta Marg (Nampally Station Road), HYDERABAD 500001	23 10 83
R14 Yudhister Marg, C Scheme, JAIPUR 302005	{ 6 34 71 6 98 32
117/418 B Sarvodaya Nagar, KANPUR 208005	{ 21 68 76 21 82 92
Patliputra Industrial Estate, PATNA 800013	6 23 05
T.C. No. 14/1421, University P.O., Palayam TRIVANDRUM 695035	{ 6 21 04 6 21 17

Inspection Offices (With Sale Point):

Pushpanjali, First Floor, 205-A West High Court Road, Shankar Nagar Square, NAGPUR 440010	2 51 71
Institution of Engineers (India) Building, 1332 Shivaji Nagar, PUNE 411005	5 24 35

*Sales Office in Calcutta is at 5 Chowringhee Approach, P. O. Princep 27 68 00
Street, Calcutta 700072

†Sales Office in Bombay is at Novelty Chambers, Grant Road, 89 65 28
Bombay 400007

‡Sales Office in Bangalore is at Unity Building, Narasimharaja Square, 22 36 71
Bangalore 560002

AMENDMENT NO. 1 APRIL 1982

TO

IS:5640-1970 METHOD OF TEST FOR DETERMINING AGGREGATES
IMPACT VALUE OF SOFT COARSE AGGREGATES

Alteration

(Page 5, clause 3.1, second sentence) - Substitute the following for the existing sentence:

'The aggregate comprising the test sample shall be dried in an oven at a temperature of 105 to 110°C for a period of four hours and cooled, until the weight becomes' constant.'

(BDC 6)

Reprography Unit, BIS, New Delhi, India