

Indian Standard

CRITERIA FOR DESIGN OF REINFORCED
CONCRETE BINS FOR THE STORAGE
OF GRANULAR AND POWDERY MATERIALS

**PART I GENERAL REQUIREMENTS AND ASSESSMENT
OF BIN LOADS**

(First Revision)

Third Reprint SEPTEMBER 1992

UDC 624'953'012'45

© Copyright 1975

BUREAU OF INDIAN STANDARDS
MANAK BHAVAN, 9 BAHADUR SHAH ZAFAR MARG
NEW DELHI 110002

Indian Standard

CRITERIA FOR DESIGN OF REINFORCED CONCRETE BINS FOR THE STORAGE OF GRANULAR AND POWDERY MATERIALS

PART I GENERAL REQUIREMENTS AND ASSESSMENT OF BIN LOADS

(*First Revision*)

Criteria for Design of Structures Sectional Committee, BDC 38

Chairman

PROF G. S. RAMASWAMY

Representing

Structural Engineering Research Centre (CSIR),
Madras

Members

SHRI M. RAMAIAH (<i>Alternate to</i> Prof G. S. Ramaswamy)	Indian Institute of Technology, New Delhi
DR B. M. AHUJA	M/s Chatterjee, Polk, Kukreja, New Delhi
PROF K. SEETHARAMULU (<i>Alternate</i>)	Indian Institute of Technology, Kanpur
SHRI B. K. CHATTERJEE	
DR Y. C. DAS	
DR P. DAYARATNAM (<i>Alternate</i>)	Development Consultants Pvt Ltd, Calcutta
SHRI P. C. DAVE	Research Designs & Standards Organization
DEPUTY DIRECTOR (STANDARDS), B & S — I	(Ministry of Railways), Lucknow
DIRECTOR (TCD)	Central Water & Power Commission, New Delhi
SHRI V. M. GAD	Atomic Energy Commission, Bombay
SHRI K. C. GHOSAL	Alokudyog Cement Service, Sawai Madhopur
SHRI A. D. GUPTA	Fertilizer Corporation of India, Sindri
SHRI V. G. HEGDE	National Buildings Organization, New Delhi
SHRI A. C. GUPTA (<i>Alternate</i>)	
SHRI G. S. IYER	Hindustan Construction Co Ltd, Bombay
SHRI V. S. KAMATH (<i>Alternate</i>)	
DR O. P. JAIN	University of Roorkee, Roorkee

(*Continued on page 2*)

© Copyright 1975

BUREAU OF INDIAN STANDARDS

This publication is protected under the *Indian Copyright Act* (XIV of 1957) and reproduction in whole or in part by any means except with written permission of the publisher shall be deemed to be an infringement of copyright under the said Act.

IS : 4995 (Part I) - 1974

(Continued from page 1)

<i>Members</i>	<i>Representing</i>
SHRI B. K. JINDAL	Central Building Research Institute (CSIR), Roorkee
SHRI B. S. GUPTA (<i>Alternate</i>)	
SHRI S. B. JOSHI	S. B. Joshi & Co Ltd, Bombay
SHRI J. S. GOKHALE (<i>Alternate</i>)	
SHRI S. P. JOSHI	Tata Consulting Engineers, Bombay
SHRI K. C. KARAMCHANDANI	Engineers India Limited, New Delhi
SHRI K. N. SINHA (<i>Alternate</i>)	
SHRI M. KUPPUSWAMY	Ministry of Food & Agriculture (Department of Food), New Delhi
SHRI MAHENDRA RAJ	In personal capacity (<i>Consulting Engineer, 12 E, Defence Colony, New Delhi</i>)
SHRI M. A. MEHTA	Concrete Association of India, Bombay
SHRI B. T. UNWALLA (<i>Alternate</i>)	
LT-COL M. H. S. MURTHY	Engineer-in-Chief's Branch, Army Headquarters
SO 2 (<i>DESIGNS</i>) (<i>Alternate</i>)	
SHRI K. C. PANDYA	M/s Shah & Pandya, Bombay
SHRI B. BALWANT RAO	Ministry of Transport (Roads Wing)
SHRI S. SEETHARAMAN (<i>Alternate</i>)	
SHRI R. A. RAMA RAO	The National Industrial Development Corporation Ltd, New Delhi
DR J. K. SRIDHAR RAO	National Committee on Science and Technology, New Delhi
SHRI T. N. SUBBA RAO	Gammon India Ltd, Bombay
SHRI P. B. PATIL (<i>Alternate</i>)	
SHRI K. G. SALVI	Hindustan Housing Factory, New Delhi
SHRI S. K. CHATTERJEE (<i>Alternate</i>)	
DR B. R. SEN	Indian Institute of Technology, Kharagpur
DR S. K. MALLICK (<i>Alternate</i>)	
SHRI C. N. SRINIVASAN	M/s C. R. Narayana Rao, Madras
SUPERINTENDING SURVEYOR OF WORKS (I)	Central Public Works Department, New Delhi
SHRI V. VENKATESWARULU (<i>Alternate</i>)	
SHRI M. C. TANDON	Stup India Ltd, Bombay
SHRI N. C. JAIN (<i>Alternate</i>)	
SHRI R. N. VAKIL	Vakil-Mehta-Sheth, Consulting Engineers, Ahmedabad
PROF P. C. VARGHESE	Indian Institute of Technology, Madras
DR S. SRINIVASA RAO (<i>Alternate</i>)	
SHRI K. VEERARAGHAVACHARY	Bharat Heavy Electricals Ltd, Tiruchirapalli
SHRI D. AJITHA SIMHA, Director (Civ Engg)	Director General, ISI (<i>Ex-officio Member</i>)

Secretary

SHRI V. SURESH
Assistant Director (Civ Engg), ISI

(Continued on page 17)

Indian Standard

CRITERIA FOR DESIGN OF REINFORCED CONCRETE BINS FOR THE STORAGE OF GRANULAR AND POWDERY MATERIALS

PART I GENERAL REQUIREMENTS AND ASSESSMENT OF BIN LOADS

(First Revision)

0. FOREWORD

0.1 This Indian Standard (Part I) (First Revision) was adopted by the Indian Standards Institution on 9 December 1974, after the draft finalized by the Criteria for Design of Structures Sectional Committee had been approved by the Civil Engineering Division Council.

0.2 Storage structures like bins (silos and bunkers) for storing different materials are one among the important structures coming up in any industrial or organized storage complex. The necessity to store and contain materials like coke, coal, ores in the various steel plants and other industrial establishments cannot be overemphasized. In cement factories as well as in construction projects, cement is stored in large silos. On the agricultural front the foodgrain storage structures play a vital role in ensuring the supply of foodgrains at all times of the year. Bulk storage of materials in bins has certain advantages over other forms of storage. Therefore, the necessity to formulate standard criteria for design of such structures has been felt and this standard is aimed at giving the necessary guidelines to arrive at the structural design of reinforced concrete bins for the storage of various materials of different properties and characteristics.

0.3 This standard published in 1968 covered the requirements of the structural design for foodgrain storage bins (silos). It has been felt that instead of bringing out one separate standard to cover the requirements of all materials other than foodgrains, it would be judicious to cover the subject under one standard in which provisions for bins storing different materials could be dealt with adequately. Therefore, the first revision of this standard had been taken up to cover the requirements of storage bins for all materials including foodgrains.

0.4 The different stored materials, such as coke, coal, ores, foodgrains, fertilizers, cement and flour can be classified either as granular or powdery materials. Extensive research work all over the world has indicated that assessment of bin loads caused due to a stored material would require different treatments depending upon whether it is a granular or powdery material. Considering this, the standard has now been brought out in two parts, namely, Part I — General requirements and assessment of bin loads, and Part II — Design criteria.

0.5 In the formulation of this standard due weightage has been given to the findings of recent research and international coordination amongst the standards and practices prevailing in different countries. This has been met with by referring to the following standards and publications:

DIN 1055 (Sheet 6) Design loads for building-bin loads. November 1964. Deutscher Normenausschuss.

PIEPER (K) and WENZEL (F). Pressure distribution in bins 1964. Verlag von Wilhelm Ernst & Sohn, Berlin, München.

REISNER (W) and ROTHE (M E). Bins and bunkers for handling bulk materials. Trans. Tech. Publications, Ohio.

0.5.1 In view of the continuing research done on flow characteristics of materials, the emphasis in the code is on structural adequacy of bins. However, as regards flow characteristics of the materials, the designers would be well advised to consult the relevant literature. This code is based on the latest available data and is amenable to review as and when more reliable information on this subject becomes available.

0.6 For the purpose of deciding whether a particular requirement of this standard is complied with, the final value, observed or calculated, expressing the result of a test or analysis, shall be rounded off in accordance with IS : 2-1960*. The number of significant places retained in the rounded off value should be the same as that of the specified value in this standard

1. SCOPE

1.1 This standard (Part I) deals with the general requirements and assessment of bin loads for granular and powdery materials.

1.2 This standard covers circular, polygonal and interstice bins.

1.3 This standard deals with the storage of materials in dry condition for which properties are given in Table 1. However, if moisture content, temperature, etc, vary, the actual values would have to be arrived at as indicated under Note of Table 1. Provisions for thermal insulations,

*Rules for rounding off numerical values (*revised*).

details of joints, weather proofing of joints, etc, are not covered in this standard.

2. TERMINOLOGY

2.0 For the purpose of this standard, the following definitions shall apply.

2.1 Aeration — A process in which air is moved through the stored material for ventilation.

2.2 Arching — A phenomenon in the bin during the emptying of a stored material giving rise to formation of arches of the material across the bin walls.

2.3 Bin — A storage structure, circular or polygonal in plan and intended for storing bulk materials in vertical direction. Silo is a bin circular or polygonal in plan. Bunker is a bin whose cross section in plan would be square or rectangular.

2.4 Bin Loads — Loads exerted by a stored material on the walls of a bin.

2.5 Foodgrain — All cereals, pulses, millets, except oil seeds.

2.6 Granular Materials — All materials having mean particle size more than 0.2 mm. No cohesion between the particles is assumed.

2.7 Interstice Bin — Bin that is formed out of the space enclosed by a battery of interconnected bins.

2.8 Powdery Materials — All materials having mean particle size less than 0.06 mm.

3. NOTATIONS

3.1 For the purpose of this standard, the following notations shall have the meaning indicated against each:

A = Horizontal interior cross-sectional area of bin.

a = Side of a square bin or shorter side of a rectangular bin.

b = Longer side of a rectangular bin.

D = Internal diameter of a circular bin.

d = Maximum diameter of the circle that can be inscribed in the bin.

h = Height of the bin.

P_a = Pressure of air injected for pneumatic emptying of a bin.

P_h = Horizontal pressure on bin walls due to stored material.

P_i = Stands for P_h or P_v or P_w as the case may be.

P_{ht} = Pressure obtained on the wall of a bin imagined to be enlarged in plan so as to make the eccentric opening concentric.

P_v = Vertical pressure on the horizontal cross section of the stored material.

P_w = Vertical load transferred to the wall due to friction between material stored and bin wall.

$R = A/U$.

U = Interior perimeter of the bin.

W = Bulk density of stored material.

Z = Depth below the levelled surface of the maximum possible fill in the bin (Fig. 1).

ϕ = Angle of internal friction of the stored material.

δ = Angle of wall friction.

$\lambda = P_h/P_v$.

λ_f = Pressure ratio during filling.

λ_e = Pressure ratio during emptying.

$\mu = \text{Coefficient of wall friction } (\mu = \tan \delta)$.

μ_f = Coefficient of wall friction during filling.

μ_e = Coefficient of wall friction during emptying.

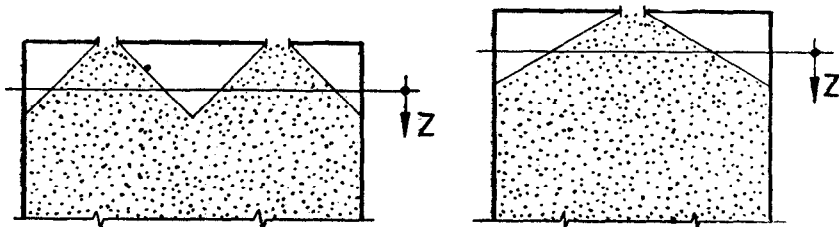

FIG. 1 DEPTH BELOW THE LEVELLED SURFACE OF THE MAXIMUM POSSIBLE FILL IN THE BIN

4. GENERAL

4.1 Location — Location of bins and specially those storing foodgrains shall conform to the relevant provisions of IS: 3453-1966* and IS: 5503 (Part I)-1969†.

*Code of practice for construction of hexagonal type of concrete-cum-masonry bins for bulk storage of foodgrains.

†General requirements for silos for grain storage: Part I Constructional requirements.

4.2 Economic Considerations — Dimensions, shape and layout of the bins, etc shall be so arrived as to effect optimum economies, the details of which are given in 4.2.1 to 4.2.3. In addition, the material handling facilities shall also be considered.

4.2.1 Dimensions — Volume of each bin and height to diameter ratio shall be governed by its storage and functional requirements of materials. To achieve a reduction in lateral pressure over a larger height, it may be preferable to select a height/diameter ratio greater than or equal to two.

4.2.2 Shape — A bin may be circular or polygonal in plan and is provided with a roof and bottom which may be flat, conical and pyramidal. In case of gravity flow bin, the angle made by the hopper with the horizontal, shall preferably be 15° more than the angle of repose of the stored material.

4.2.3 Layout — Storage bins may be either free standing individual bins or arranged in the form of batteries of free standing bins or bins interconnected in one or both the directions.

5. DESIGN PARAMETERS

5.0 Design parameters of stored materials include bulk density, angle of internal friction, angle of wall friction and pressure ratio (λ) which are the governing factors for the computation of bin loads. Storage and flow characteristics of granular materials differ widely from those of powdery materials.

5.1 Shape of the Bin — The cross-sectional shape of the bin is taken into account by the factor $R = A/U$. In the case of interstice bins, the value of R shall be approximated by the value of R for an equivalent square bin of the same area.

5.2 Bulk Density and Angle of Internal Friction — Table 1 gives the values of bulk density and angle of internal friction for some of the commonly stored materials.

5.3 Wall Friction — In the absence of reliable experimental data, the angle of wall friction for granular and powdery materials, irrespective of the roughness of bin wall, may be taken as given in Table 2.

5.3.1 For materials having mean particle diameters in between 0.06 mm and 0.2 mm the necessary values of angle of wall friction may be obtained by linear interpolation. If there is a possibility that the effect of moisture, pressure increase due to consolidation, etc, may change the angle of wall friction, ϕ to a value than that indicated in Table 2, then its value should preferably be determined experimentally.

5.3.2 Pressure Ratio — For the purpose of computing bin loads, the ratio of horizontal to vertical pressure, λ , may be assumed as given in Table 2.

TABLE 1 BULK DENSITY AND ANGLE OF INTERNAL FRICTION OF STORED MATERIALS

(Clauses 1.3, 5.2 and 6.2.1)

Sl. No.	MATERIAL	BULK DENSITY, W (kg/m ³)	ANGLE OF INTERNAL FRICTION (ϕ°)
(1)	(2)	(3)	(4)
i)	Food grains and milled products:		
a)	Wheat	850	28
b)	Paddy	575	36
c)	Rice	900	33
d)	Maize	800	30
e)	Barley	690	27
f)	Corn	800	27
g)	Sugar	820	35
h)	Wheat flour	700	30
ii)	Coal:		
a)	Bituminous, dry and broken	800	35
b)	Raw (10 mm size)	1 040	40
c)	Pulverized, aerated	570	20
d)	Pulverized, compacted	890	25
iii)	Anthracite:		
a)	Dry and broken	890	27
b)	Pulverized, aerated	650	20
c)	Pulverized, compacted	970	25
iv)	Coke:		
	Dry, broken and loose	430	30
v)	Ash :		
a)	Dry and compacted	720	40
b)	Loose	650	30
c)	From pulverized fuel, dry and loose	1 120	30
vi)	Ores:		
a)	Haematite (10 mm size)	3 700	35
b)	Magnetite	4 000	35
c)	Manganese	2 570-2 900	35
d)	Limestone	1 300-1 800	35
e)	Copper and zinc	2 570-2 900	35
f)	Lead	5 250	35
vii)	Others:		
a)	Cement	1 550	25
b)	Cement clinker	1 650	35-37
c)	Pulverized lime	1 350	25

NOTE—The values given in Table 1 may not be taken to be applicable universally. The bulk density and angle of internal friction depend upon many variable factors, such as moisture content, particle size and temperature, etc. Wherever possible tests shall be conducted on actual samples to obtain the above values under actual conditions of storage.

TABLE 2 ANGLE OF WALL FRICTION AND PRESSURE RATIO

(Clauses 5.3, 5.3.1, 5.3.2 and 6.2.1)

Sl. No.	MATERIAL	ANGLE OF WALL FRICTION, δ		PRESSURE RATIO, λ	
		While Filling	While Emptying	While Filling	While Emptying
(1)	(2)	(3)	(4)	(5)	(6)
i)	Granular materials with mean particle diameter ≥ 0.2 mm	0.75ϕ	0.6ϕ	0.5	1.0
ii)	Powdery materials (except wheat flour) with mean particle diameter < 0.06 mm	1.0ϕ	1.0ϕ	0.5	0.7
iii)	Wheat flour	0.75ϕ	0.75ϕ	0.5	0.7

6. ASSESSMENT OF BIN LOADS

6.0 Bin Loads — There are three types of loads caused by a stored material in a bin as shown in Fig. 2. They are:

- horizontal load or horizontal pressure (P_h) acting on the side walls,
- vertical load or vertical pressure (P_v) acting on the cross-sectional area of the bin filling, and
- frictional wall load or frictional wall pressure (P_w) introduced into the side walls through wall friction.

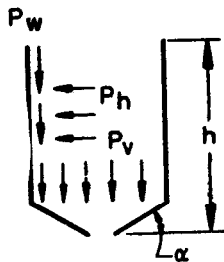

FIG. 2 BIN LOADS

6.0.1 In this standard Janssen's theory has been used for the assessment of bin loads in which the value of λ , δ and W are assumed to be constant

along the bin height. However, where necessary, the variation of W and ζ along the depth may be determined experimentally and used in the development-derivation-of Janssen's theory for computation of bin loads. Designs can be carried out using mass/funnel flow characteristics, details for which are not at present covered in the scope, and designers are well advised to consult relevant literature.

6.1 Bin Loads due to Granular Materials

6.1.1 Normal Filling and Emptying

6.1.1.1 Maximum pressures — The maximum values of the horizontal pressures on the wall (P_h), the vertical pressure on the horizontal cross section of the stored material (P_v) and the vertical load transferred to the wall per unit area due to friction (P_w) shall be calculated as follows (see also Fig. 2):

<i>Name of Pressure</i>	<i>During Filling</i>	<i>During Emptying</i>
Maximum P_w	WR	WR
Maximum P_h	$\frac{WR}{\mu_f}$	$\frac{WR}{\mu_e}$
Maximum P_v	$\frac{WR}{\mu_f \lambda_f}$	$\frac{WR}{\mu_e \lambda_e}$

6.1.1.2 P_v and P_w cannot be maximum at the same time. Hence for the design of hopper bottom, maximum P_v (during filling) should be considered and this value will be the maximum P_v at the particular depth multiplied by area of cross section of bin. The maximum P_w (emptying) shall be calculated when the side walls are to be designed at a particular depth as:

$$\sum_0^z P_w = \pi DWR \left(z + \frac{1}{\lambda_{oe}} \cdot e^{-z/\lambda_{oe}} - \lambda_{oe} \right)$$

If h/D ratio is less than or equal to 2, the values shall be:

- a) the total weight of stored material when hopper bottom is to be designed, and
- b) the value indicated as P_w when side walls are to be designed.

6.1.1.3 Variation of pressure along the depth — The variation of P_w , P_h and P_v along the depth of the bin may be obtained from the expression given below (Fig. 3):

$$P_i (z) = (P_i)_{max} (1 - e^{-z/\lambda_o})$$

where P stands for pressure and suffix i stands for w , h or v corresponding to the pressures P_w , P_h or P_v respectively and Z_o assumes the values given below:

During filling, $Z_{of} = R/\mu_f\lambda_f$
 During emptying, $Z_{oe} = R/\mu_e\lambda_e$

Appendix A gives the values of $(1 - e^{-Z/Z_o})$ for different values of Z/Z_o . Intermediate values may be obtained with sufficient accuracy by linear interpolation.

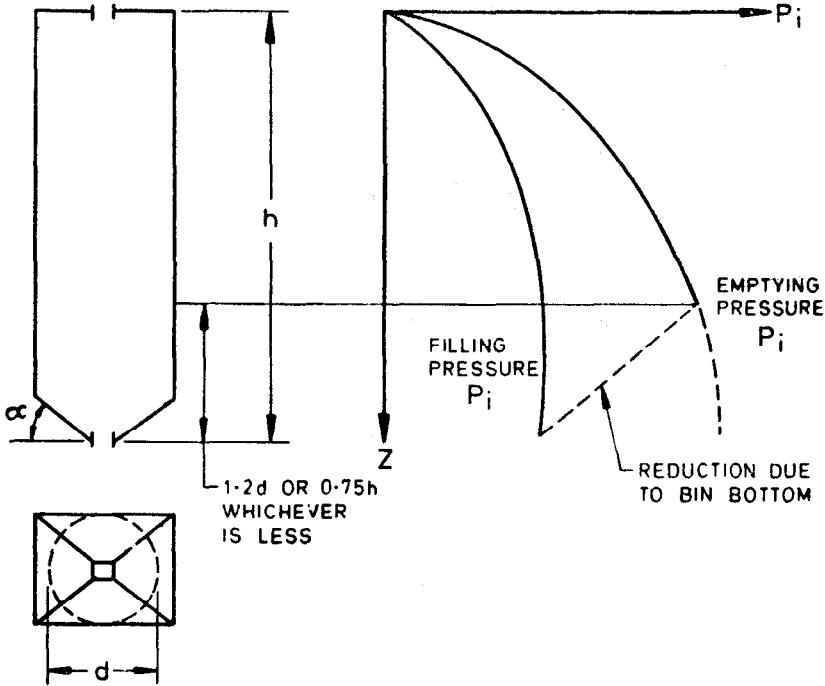

FIG. 3 PRESSURE VARIATION ALONG BIN DEPTH

6.1.1.4 *Governing loading cases* — In general, the loading cases as indicated in Table 3 will give the governing design pressures.

TABLE 3 GOVERNING LOADING CASES

PRESSURE	GRANULAR MATERIAL	POWDERY MATERIAL
(1)	(2)	(3)
P_w	Emptying	Filling = Emptying
P_h	Emptying	Filling = Emptying
P_v	Filling	Filling

6.2 Bin Loads due to Powdery Materials

6.2.1 Normal Filling and Emptying — Maximum design pressures under this case shall be computed as specified under 6.1. Appropriate values of various design parameters shall be taken from Tables 1 and 2.

6.2.2 Homogenization — In the case of homogenizing bin, the filling consists of powdery materials which is circulated by compressed air for mixing purposes. During homogenization of powdery materials the lateral and vertical pressures depend upon the volume of the empty space available in the upper portion of the bin. This may be kept about 40 percent of the total volume of the bin. The lateral and vertical pressures shall be calculated using the following expression and should not be less than pressure evaluated as in 6.1.1:

$$P_h = P_v = 0.6 WZ$$

6.2.3 Rapid Filling — During rapid filling — material being filled at a rate higher than the minimum filling speed — up to a certain height Z_n from the top layer, the upper stored material flows like a fluid. The following expression may be used for computing the governing lateral pressures during rapid filling of a silo with a filling speed v :

$$\text{Rapid filling } (P_h) = 0.8 W.Z_n$$

where

$$Z_n = (v - v_0) t;$$

v = actual filling speed, m/h;

v_0 = the minimum filling speed, m/h; and

t = time lapse of one hour.

NOTE — The values of v_0 shall be taken as follows:

Material	v_0
Cement	2.6
Pulverized lime	1.4
Wheat flour	4.8

6.2.3.1 Application of the formula given in 6.2.3 is only for materials filled at a rate more than the minimum filling speed for different materials. For speeds lesser than the minimum filling speed, the pressures in 6.1 shall apply. However, when the filling speed exceeds the minimum filling speed, a check should be made for the maximum pressure due to rapid filling from the greater values arrived at according to the formula given in 6.2.3 and the values given in 6.2.1, 6.2.2, 6.2.4 and 6.3.

6.2.4 Pneumatic Emptying — During pneumatic emptying air under pressure is blown inside the bin through a number of small holes located in the bin walls near the bin bottom. This causes liquefaction of the material in

the lower portion of the bin and gives rise to higher values of P_h and P_v (both being equal). The lateral pressures during pneumatic emptying shall be calculated as shown in Fig. 4.

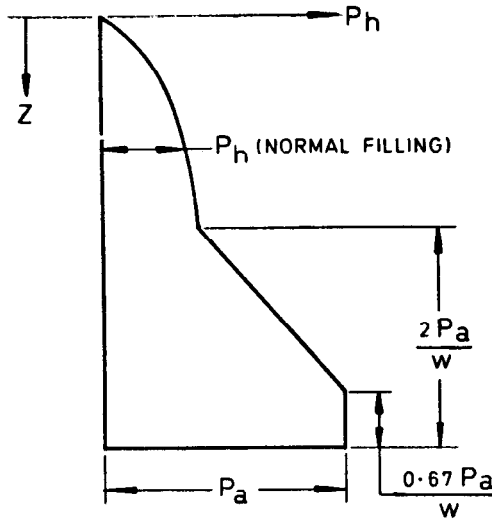

FIG. 4 PRESSURE SCHEME FOR PNEUMATIC EMPTYING

6.3 Effects Causing Increase in Bin Loads

6.3.1 Eccentric Emptying — Eccentric emptying of a bin gives rise to increased horizontal loads non-uniformly distributed over the periphery and extending over the full height of the bin. Eccentric outlets in bins shall be avoided as far as possible, and, where they have to be provided to meet functional requirements, due consideration shall be given in design to the increased pressure experienced by the walls. Till more information is available, the increased pressure may be calculated as given under **6.3.1.1**. This increased pressure shall be considered, for the purpose of design, to be acting both on the wall nearer to the outlet as well as on the wall on the opposite side.

6.3.1.1 The additional pressure P'_h shall be considered to act for the full height of the bin and is obtained from the expression given below:

$$P'_h = P_{hi} - P_h$$

where

P_{hi} = pressure obtained on the wall of the bin imagined to be enlarged in plan so as to make the eccentric opening concentric, and

P_h = horizontal pressure on the wall due to stored material.

P_{hi} and P_h shall be obtained as per **6.1.1**,

6.3.1.2 The enlarged shape of the bin which is required for the purpose of computation of the pressure P_{hi} shall be obtained as shown in Fig. 5.

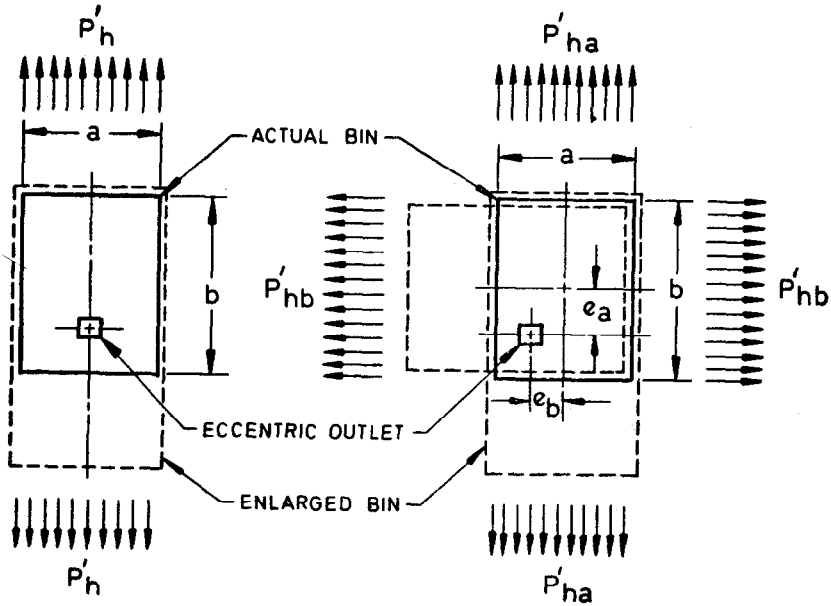

5A RECTANGULAR BIN

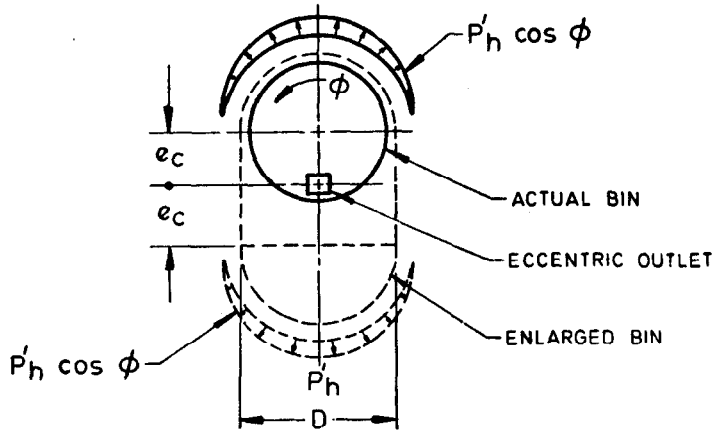

5B CIRCULAR BIN

FIG. 5 EFFECT OF EMPTYING THROUGH ECCENTRIC OUTLETS

6.3.1.3 The effect of eccentric outlets may be ignored in design if the eccentricity is less than $d/6$ or the height of the bin is not greater than $2d$, where d is the maximum possible diameter of the circle that can be inscribed in the bin.

6.3.2 Arching of Stored Material — Some stored materials are susceptible to arching action across the bin walls. The frequent collapse of such arches gives rise to increased vertical pressures. The vertical pressure on the bottom of the bin storing such materials shall be taken as twice the filling pressure, P_v ; however the load need not be assumed to be greater than $W.Z$.

6.3.3 Aeration of Stored Material — When bins are provided with equipment for ventilating the bin filling at rest, a distinction must be made between bins for granular material and bins for powdery material.

6.3.3.1 When the material is granular, an increase in the horizontal pressures is to be expected. Therefore, the horizontal pressure P_h , as calculated as per **6.1.1.1**, for filling, are to be increased by the inlet pressure of the air over that portion of the height of the bin in which the air inlets are located. From the level of the highest inlet upwards, this increase in pressure may be tapered off uniformly down to zero at the top of the bin.

6.3.3.2 For powdery materials the measurements made so far do not indicate any significant increases in load when ventilating.

6.3.3.3 Bins for storage of powdery materials are often equipped with devices for pneumatic emptying, and these bring about a loosening of the bin filling in the region of the outlet. In this case also, no significant increases in load due to the air supply have so far been detected.

6.3.4 Discharge Promoting Devices — Modern bins storing various materials may be provided with various discharge promoting devices such as inserts, bridge like structure above the outlet or relief nose. In all such cases the effective cross section of the bin is locally reduced. Recent research has given an indication that in such bins the horizontal wall pressures are excessively increased locally or along the entire bin height. In the absence of reliable knowledge available on the subject the designer is cautioned to assess the wall loads for such bins most judiciously and by carrying out experimental investigation.

6.4 Effects Causing Decrease in Bin Loads — In view of the load reducing effect of the bin bottom, the horizontal pressure during emptying may be reduced up to a height $1.2 d$ or $0.75 h$ whichever is smaller from the bin bottom. This may be considered as varying linearly from the emptying pressure at this height to the filling pressure at the bin bottom (see also Fig. 3).

APPENDIX A

(Clause 6.1.1.3)

VALUES OF $1 - e^{-Z/Z_0}$ FOR DIFFERENT VALUES Z/Z_0

Z/Z_0 (1)	$1 - e^{-Z/Z_0}$ (2)	Z/Z_0 (1)	$1 - e^{-Z/Z_0}$ (2)	Z/Z_0 (1)	$1 - e^{-Z/Z_0}$ (2)
0.1	0.095 2	1.6	0.798 1	3.1	0.955 0
0.2	0.181 3	1.7	0.817 3	3.2	0.959 2
0.3	0.259 2	1.8	0.834 7	3.3	0.963 1
0.4	0.329 7	1.9	0.850 4	3.4	0.966 6
0.5	0.393 5	2.0	0.864 7	3.5	0.969 8
0.6	0.451 2	2.1	0.877 5	3.6	0.972 7
0.7	0.503 4	2.2	0.889 2	3.7	0.975 3
0.8	0.550 7	2.3	0.899 7	3.8	0.977 6
0.9	0.593 4	2.4	0.909 3	3.9	0.979 8
1.0	0.632 1	2.5	0.917 9	4.0	0.981 7
1.1	0.667 1	2.6	0.925 7	—	—
1.2	0.698 8	2.7	0.932 8	—	—
1.3	0.727 5	2.8	0.939 2	—	—
1.4	0.753 4	2.9	0.945 0	—	—
1.5	0.776 9	3.0	0.950 2	α	1.000 0

(Continued from page 2)

Panel for Reinforced Concrete Bins and Silos, BDC 38 : P2

<i>Convener</i>	<i>Representing</i>
SHRI K. VEERARAGHAVACHARY	Bharat Heavy Electricals Ltd, Tiruchirapalli
<i>Members</i>	
SHRI P. C. DAVE	Development Consultants Pvt Ltd, Calcutta.
SHRI A. K. BHATTACHARYYA (<i>Alternate</i>)	
SHRI S. GOPALAKRISHNAN	Structural Engineering Research Centre (CSIR), Roorkee
SHRI M. KUPPUSWAMY	Ministry of Food & Agriculture (Department of Food), New Delhi
DE S. K. MALLIK	Indian Institute of Technology, Kharagpur
SHRI S. NAHARAY	Engineering Construction Corporation Ltd, Madras
SHRI A. RAMAKRISHNA (<i>Alternate</i>)	
SHRI P. B. PATIL	Gammon India Ltd, Bombay
SHRI G. R. HARIDAS (<i>Alternate</i>)	

BUREAU OF INDIAN STANDARDS

Headquarters:

Manak Bhavan, 9 Bahadur Shah Zafar Marg, NEW DELHI 110002

Telephones : 331 01 31, 331 13 75

Telegrams : Manaksanatha
(Common to all offices)

Regional Offices:

	<i>Telephones</i>
Central : Manak Bhavan, 9 Bahadur Shah Zafar Marg, NEW DELHI-110002	[331 01 31 331 13 75
*Eastern : 1/14 C.I.T. Scheme VII M, V. I. P. Road, Maniktola, CALCUTTA 700054	36 24 99
Northern : SCO 445-446, Sector 35-C, CHANDIGARH 160036	[2 18 43 3 16 41
Southern : C. I. T. Campus, MADRAS 600113	{ 41 24 42 41 25 19 41 29 16
†Western : Manakalaya, E9 MIDC, Marol, Andheri (East), BOMBAY 400093	6 32 92 95

Branch Offices:

'Pushpak' Nurmohamed Shaikh Marg, Khanpur, AHMEDABAD 380001	[2 63 48 2 63 49
‡Peenya Industrial Area, 1st Stage, Bangalore Tumkur Road BANGALORE 560058	[38 49 55 38 49 56
Gangotri Complex, 5th Floor, Bhadbhada Road, T. T. Nagar, BHOPAL 462003	6 67 16
Plot No. 82/83, Lewis Road, BHUBANESHWAR 751002	5 36 27
53/5, Ward No. 29, R. G. Barua Road, 5th Byelane, GUWAHATI 781003	3 31 77
5-8-56C L. N. Gupta Marg (Nampally Station Road), HYDERABAD 500001	23 10 83
R1 ^A Yudhister Marg, C Scheme, JAIPUR 302005	[6 34 71 6 98 32
117/418 B Sarvodaya Nagar, KANPUR 208005	[21 68 76 21 82 92
Patliputra Industrial Estate, PATNA 800013	6 23 05
T.C. No. 14/1421, University P.O., Palayam TRIVANDRUM 695035	[6 21 04 6 21 17

Inspection Office (With Sale Point) :

Pushpanjali, 1st Floor, 205-A West High Court Road, Shankar Nagar Square, NAGPUR 440010	2 51 71
Institution of Engineers (India) Building, 1332 Shivaji Nagar, PUNE 411005	5 24 35

*Sales Office in Calcutta is at 5 Chowringhee Approach, P.O. Princep Street, Calcutta 700072 27 68 00

†Sales Office in Bombay is at Novelty Chambers, Grant Road, Bombay 400007 89 65 28

‡Sales Office in Bangalore is at Unity Building, Narasimharaja Square Bangalore 560002 22 36 71

AMENDMENT NO. 1 JANUARY 1987

TO

IS : 4995 (Part 1) - 1974 CRITERIA FOR DESIGN OF REINFORCED CONCRETE BINS FOR THE STORAGE OF GRANULAR AND POWDERY MATERIALS

PART 1 GENERAL REQUIREMENTS AND ASSESSMENT OF BIN LOADS

(First Revision)

(Page 10, clause 6.1.1.2) — Substitute the following for the existing formula:

$$\sum_0^z P_w = \pi DWR \left[z - z_{ce} (1 - e^{-z/z_{ce}}) \right]$$

(Page 12, clause 6.2.3, Note) — Add 'm/h' as unit under v_o in the informal table given in the Note.

(Page 13, Fig. 4) — Substitute the following for the existing figure:

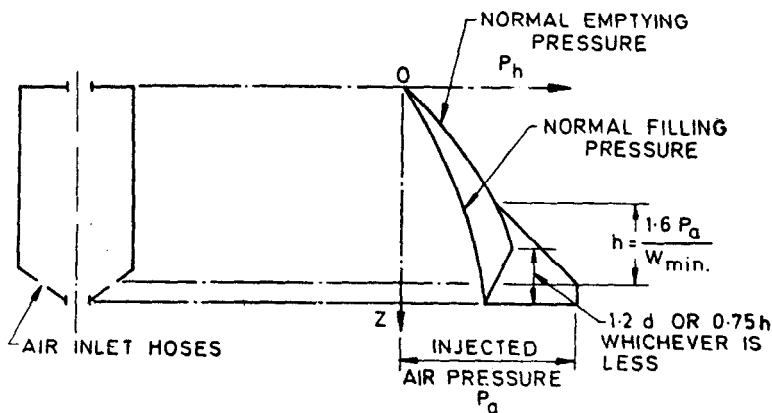

W_{min} = Minimum bulk density of the stored material.

FIG. 4 PRESSURE SCHEME DURING PNEUMATIC EMPTYING

(Page 15, clause 6.3.3.3) — Substitute the following for the existing clause:

'6.3.3.3 Bins for storage of powdery materials are often equipped with devices for pneumatic emptying and when these devices are used for aeration of stored material, loosening of the material in the region of the outlet occurs. In this case, no significant increase in load due to the air supply has so far been detected.

(B3C 38)