

Indian Standard

METHOD FOR
SUBSURFACE SOUNDING FOR SOILS
PART III STATIC CONE PENETRATION TEST
(*First Revision*)

Second Reprint NOVEMBER 1994

UDC 624.131.381

© *Copyright* 1977

BUREAU OF INDIAN STANDARDS
MANAK BHAVAN, 9 BAHADUR SHAH ZAFAR MARG
NEW DELHI 110002

Indian Standard

METHOD FOR SUBSURFACE SOUNDING FOR SOILS

PART III STATIC CONE PENETRATION TEST

(*First Revision*)

Soil Engineering Sectional Committee, BDC 23

Chairman

Representing

PROF DINESH MOHAN

Central Building Research Institute (CSIR),
Roorkee

Members

- ADDITIONAL DIRECTOR RESEARCH Railway Board (Ministry of Railways)
(RDSO)
DEPUTY DIRECTOR RESEARCH
(RDSO) (*Alternate*)
- PROF ALAM SINGH University of Jodhpur, Jodhpur
LT-COL AVTAR SINGH Engineer-in-Chief's Branch, Army Headquarters
MAJ R. R. SUDHINDRA (*Alternate*)
- DR A. BANERJEE Cementation Co Ltd, Calcutta
SHRI S. GUPTA (*Alternate*)
SHRI K. N. DADINA In personal capacity (P-920, 'P', New Alipore,
Calcutta 700053)
SHRI A. G. DASTIDAR In personal capacity (5, Hungerford Court, 12/1
Hungerford Street, Calcutta 700017)
SHRI R. L. DEWAN Irrigation Research Institute, Khagaul, Patna
*DR G. S. DHILLON Irrigation Department, Government of Punjab
RESEARCH OFFICER (SOILS)
(IPRI) (*Alternate*)
SHRI A. H. DIVANJI Rodio Foundation Engineering Ltd; and Hazarat &
Co, Bombay
SHRI A. N. JANGLE (*Alternate*)
DR SHASHI K. GULNATI Indian Institute of Technology, New Delhi
DR G. V. RAO (*Alternate*)
SHRI V. G. HEGDE National Buildings Organization, New Delhi
SHRI S. H. BALCHANDANI (*Alternate*)

(*Continued on page 2*)

*Also represents Indian Geotechnical Society, New Delhi.

© Copyright 1977

BUREAU OF INDIAN STANDARDS

This publication is protected under the *Indian Copyright Act* (XIV of 1957) and reproduction in whole or in part by any means except with written permission of the publisher shall be deemed to be an infringement of copyright under the said Act.

IS : 4968 (Part III) - 1976

(Continued from page 1)

<i>Members</i>	<i>Representing</i>
SHRI O. P. MALHOTRA SHRI J. S. MARYA	Public Works Department, Government of Punjab Roads Wing, Ministry of Shipping and Transport, New Delhi
SHRI N. SEN (<i>Alternate</i>) SHRI G. D. MATHUR	Public Works Department, Government of Uttar Pradesh
SHRI D. C. CHATURVEDI (<i>Alternate</i>) SHRI R. S. MELKOTE	Central Water Commission, New Delhi
SHRI C. SUDHINDRA (<i>Alternate</i>) SHRI T. K. NATARAJAN	Central Road Research Institute (CSIR), New Delhi Hindustan Construction Co Ltd, Bombay
REPRESENTATIVE RESEARCH OFFICER	Building and Roads Research Laboratory, Chandigarh
DR K. R. SAXENA SECRETARY	Engineering Research Laboratories, Hyderabad Central Board of Irrigation & Power, New Delhi
DEPUTY SECRETARY (<i>Alternate</i>) *DR SHAMSHER PRAKASH	University of Roorkee, Roorkee
DR GOPAL RANJAN (<i>Alternate</i>) SHRI H. D. SHARMA	Irrigation Research Institute, Roorkee
SUPERINTENDING ENGINEER	Public Works Department, Government of Tamil Nadu
EXECUTIVE ENGINEER (<i>Alternate</i>) SHRI B. T. UNWALLA	Concrete Association of India, Bombay
SHRI T. M. MENON (<i>Alternate</i>) SHRI H. C. VERMA	All India Instruments Manufacturers & Dealers Association, Bombay
SHRI V. K. VASUDEVAN (<i>Alternate</i>) SHRI D. AJITHA SIMHA, Director (Civ Engg)	Director General, ISI (<i>Ex-officio Member</i>)

Secretary

SHRI G. RAMAN
Deputy Director (Civ Engg), ISI

Site Exploration and Investigation for Foundations Subcommittee, BDC 23 : 2

Convener

SHRI R. S. MELKOTE Central Water Commission, New Delhi

Members

SHRI C. SUDHINDRA (*Alternate* to
Shri R. S. Melkote)
PROF ALAM SINGH University of Jodhpur, Jodhpur
LT-COL AVTAR SINGH Engineer-in-Chief's Branch, Army Headquarters
MAJ R. R. SUDHINDRA (*Alternate*)

(Continued on page 14)

*Also represents Institution of Engineers (India), Delhi Centre.

Indian Standard
METHOD FOR
SUBSURFACE SOUNDING FOR SOILS
PART III STATIC CONE PENETRATION TEST
(*First Revision*)

0. FOREWORD

0.1 This Indian Standard (Part III) (First Revision) was adopted by the Indian Standards Institution on 22 December 1976, after the draft finalized by the Soil Engineering Sectional Committee had been approved by the Civil Engineering Division Council.

0.2 Among the field sounding tests the static cone test is a valuable method of recording variation in the *in situ* penetration resistance of soils, in cases where the *in situ* density is disturbed by boring operations, thus making the standard penetration test unreliable especially under water. The results of the test are also useful in determining the bearing capacity of the soil at various depths below the ground level. In addition to bearing capacity values it is also possible to determine by this test the skin friction values used for the determination of the required lengths of piles in a given situation. The static cone test is most successful in soft or loose soils like silty sands, loose sands, layered deposits of sands, silts and clays as well as in clayey deposits.

0.2.1 Experience indicates that a complete static cone penetration test up to depths of 15 to 20 m can be completed in a day with manual operations of the equipment, making it one of the inexpensive and fast methods of sounding available for investigation; in fact, in Europe it is invariably used for exploratory stage of investigations when both time and money are at a premium. In areas where some information regarding the foundation strata is already available, the use of test piles and loading tests thereof can be avoided by conducting static cone penetration tests.

0.3 This standard was first published in 1971. In this revision several changes have been made taking into consideration the experience gained in conducting the test and in the manufacture of the equipment. The essential requirements of the friction jacket have been added; tolerances have been indicated for the essential requirements; a rate of travel has been specified for the engine driven equipment. Opportunity has also been taken to give the requirements and example in SI units.

IS : 4968 (Part III) - 1976

0.4 In the formulation of this standard due weightage has been given to international co-ordination among the standards and practices prevailing in different countries in addition to relating it to the practice in the field in this country.

0.5 In reporting the result of a test or analysis made in accordance with this standard, if the final value, observed or calculated, is to be rounded off, it shall be done in accordance with IS : 2-1960*.

1. SCOPE

1.1 This standard (Part III) covers the procedure for the determination of the cone resistance and friction resistance of soil at various depths below ground surface by the static cone method.

1.1.1 This standard gives the procedure for the test only and certain essential details of the equipment but does not include complete design of the equipment.

2. EQUIPMENT

2.1 Steel Cone — The cone shall be of suitable steel with its tip hardened. It shall have an apex angle of $60^\circ \pm 15$ minutes and overall base diameter of $35.7 \begin{smallmatrix} +0 \\ -0.1 \end{smallmatrix}$ mm giving a cross-sectional area of 10 cm^2 (see Fig. 1). The cone shall be so designed as to prevent the intrusion of soil particles into the moving parts of the cone assembly.

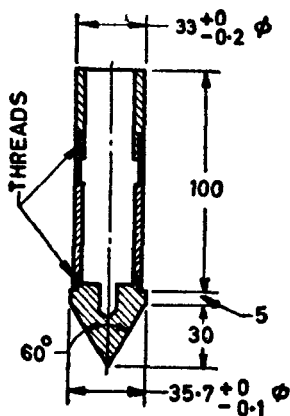

All dimensions in millimetres.

FIG. 1 CONE ASSEMBLY (WITHOUT FRICTION JACKET)

*Rules for rounding off numerical values (revised).

2.2 Friction Jacket — The friction jacket shall be of high carbon steel and of dimensions shown in Fig. 2.

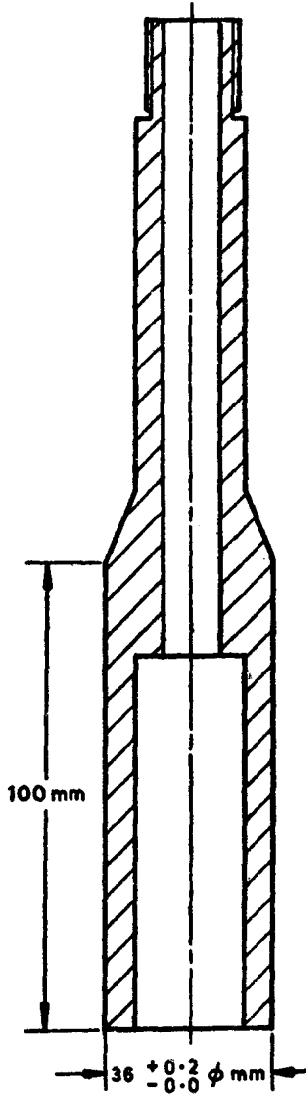
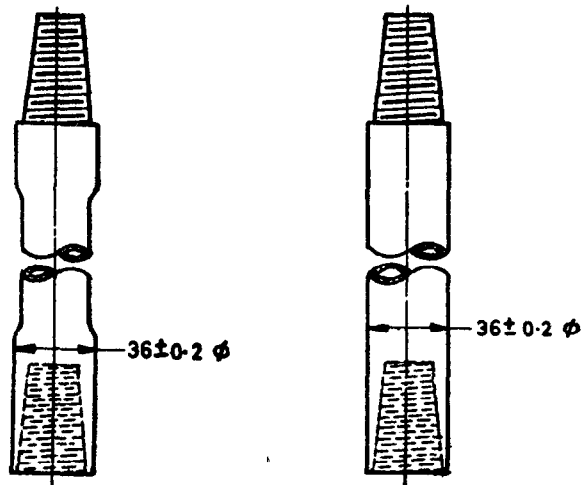

FIG. 2 FRICTION JACKET

2.3 Sounding Rod — Steel rod of 15 mm diameter which can be extended with additional rods of 1 m each in length. The sounding rod should be such that the base of the cone mentioned in 2.1 could be attached to it.

2.4 Mantle Tube — The mantle tube shall be of steel and is meant for guiding the sounding rod which goes through the mantle tube. The mantle tube should be in length of one metre with flush coupling. The diameter of the mantle tube may be non-uniform or uniform (*see Fig. 3*). In the manually operated equipment, for ease of operations, the non-uniform mantle tube is generally used.



3A Non-Uniform Dia

3B Uniform Dia

FIG. 3 MANTLE TUBE

2.5 Driving Mechanism — The driving mechanism should have a capacity of 2 to 3 tonnes for the manually operated equipment and 10 tonnes for the mechanically operated equipment. The driving mechanism essentially consists of a rack and pinion arrangement operated by a winch. The reaction for the thrust may be obtained by suitable devices capable of taking loads greater than the capacity of the equipment.

2.5.1 The hand-operated winch may be provided with handles on both sides of the driving frame to facilitate driving by four persons for loads greater than 2 000 kg. The winch should be equipped for two speeds controlled by 2 gears. The gear should be capable of being operated in slow and fast positions for penetration or withdrawal of the cone-friction jacket assembly.

2.5.2 For the engine driven equipment the rate of travel should be such that the penetration obtained in the soil during the test is between 1 to 1.5 cm/s.

2.6 Measuring Equipment — The sounding apparatus should be provided with hydraulically operated measuring device by which the pressure developed is indicated on the gauges. The cross-sectional area of the plunger of the measuring head may be either 10 cm² (same as the cross-sectional area of the cone) or 20 cm². Two pressure gauges should be connected to the driving head, one for high pressure and the other for low pressure, as follows for the plunger area of 20 cm² (see Note):

a) For the 2 to 3 t equipment:

1) 0 to 1000 kN/m² (0 to 10 kgf/cm²) with 25 kN/m² (0.25 kgf/cm²) markings

or

0 to 5000 kN/m² (0 to 50 kgf/cm²) with 50 kN/m² (0.50 kgf/cm²) markings

and

2) 0 to 15000 kN/m² (0 to 160 kgf/cm²) with 150 kN/m² (1.5 kgf/cm²) markings.

As an alternative, a proving ring may also be used to record the penetration resistance of the cone fitted to a hand operated machine.

b) For the 10 t equipment:

1) 0 to 10000 kN/m² (0 to 100 kgf/cm²) with 100 kN/m² (1 kgf/cm²) markings

and

2) 0 to 60000 kN/m² (0 to 600 kgf/cm²) with 500 kN/m² (5 kgf/cm²) markings.

NOTE — If the plunger area is 10 cm², the capacity of the gauges and calculations should be adjusted appropriately.

2.6.1 In both the 2 to 3 t and 10 t equipment, the pressure gauges shall be so connected that the pressure gauge with the smaller capacity can be cut off both manually and automatically when the applied pressure exceeds its capacity.

2.7 Other Requirements of the Equipment — The equipment shall be so designed as to allow for pushing into the ground the cone alone, and the friction jacket fitted immediately above the cone and the cone together, alternatively, through depths of a minimum of 35 mm each, each time. Provision shall also be made to enable the entire assembly to be advanced together continuously if skin friction readings are not required to be determined separately.

3. PROCEDURE

3.1 Basically the test procedure for determining the static cone and frictional resistances consists of pushing the cone alone through the soil strata to be tested, then the cone and the friction jacket, and finally the entire assembly in sequence and noting the respective resistance in the first two cases. The cone is pushed through a distance in accordance with the design of the equipment (*see 2.7*) and the need for the substrata and the cone resistance noted. Thereafter, the cone and the friction jacket are pushed together for a distance depending upon the design of the cone and friction jacket assembly and the combined value of cone and friction resistance noted. This procedure is repeated at predetermined intervals. The set up for the test is illustrated in Fig. 4.

3.2 The equipment shall be securely anchored to the ground at the test point for obtaining the required reaction.

3.2.1 The rack of the driving mechanism shall be brought to the top most position. The cone-friction jacket assembly shall be connected to the first sounding rod and the mantle tube. This assembly shall be positioned over the test point through the mantle tube guide and held vertically. The plunger of the driving mechanism shall be brought down so as to rest against the protruding sounding rod.

3.2.2 For obtaining the cone resistance, the sounding rod only shall be pushed. Switching the gear clutch to the slow position, the drive handle shall be operated at a steady rate of 1 cm/s approximately (*see Note*) so as to advance the cone only to a depth which is possible with the cone assembly available (*see 2.7*). During this pushing, the mean value of the resistance as indicated by the Bourdon gauges shall be noted ignoring erratic changes.

NOTE — In order to standardize the test procedure a rate of 1 cm/s has been specified. Tests conducted at slower rates (0.5 cm/s and 1/3 cm/s) have shown that in the case of both cohesive and non-cohesive soils the effect of the time-rate of penetration on the cone resistance was not appreciable within the limits of these rates. Tests conducted at faster rates (2 cm/s and 3 cm/s) have shown the following effects:

- a) For cohesive soils with cone resistance of above 1 000 kN/m² (10 kgf/cm²) the effects of these rates were not significant;
- b) For cohesive soils with cone resistance of 400 kN/m² (4 kgf/cm²) and lower, the values decreased appreciably with increase in the rate of penetration; and
- c) For non-cohesive soils with cone resistance varying from 1 500 to 8 000 kN/m² (15 to 80 kgf/cm²), the cone resistance increased by about 20 percent.

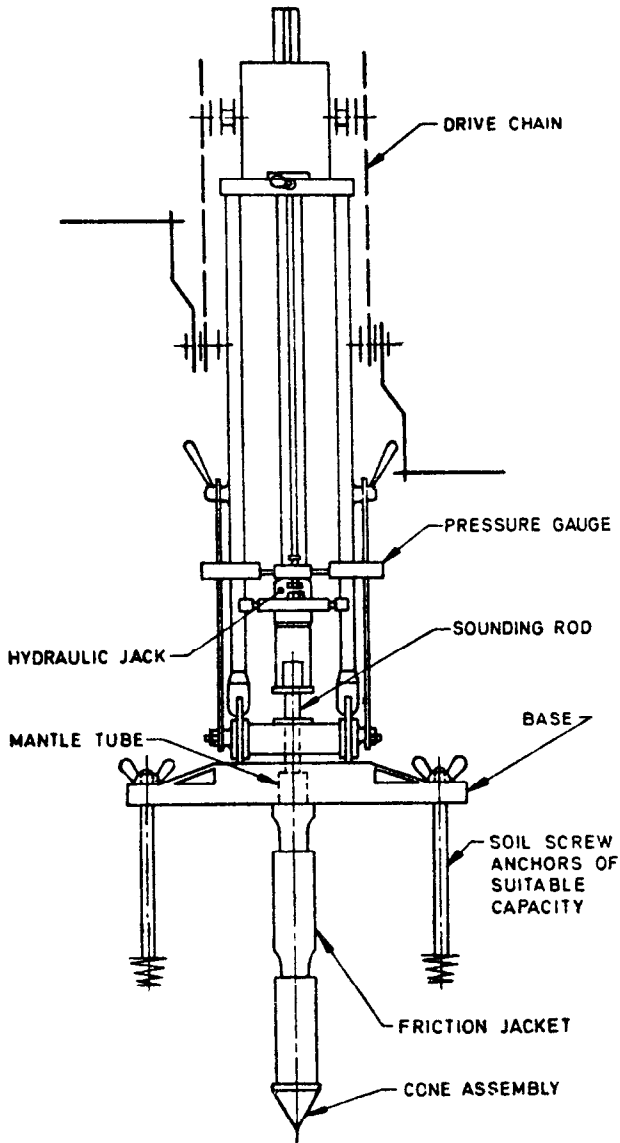

FIG. 4 TYPICAL SET UP FOR STATIC CONE PENETROMETER
(HAND OPERATED)

3.2.3 For finding the combined cone and friction resistance of the soil the sounding rod shall be pushed to the extent the cone has been pushed as in 3.2.2 at the rate of 1 cm/s (see Note under 3.2.2) noting the mean resistance on the gauges, ignoring erratic changes. The sequence of operations is illustrated in Fig. 5.

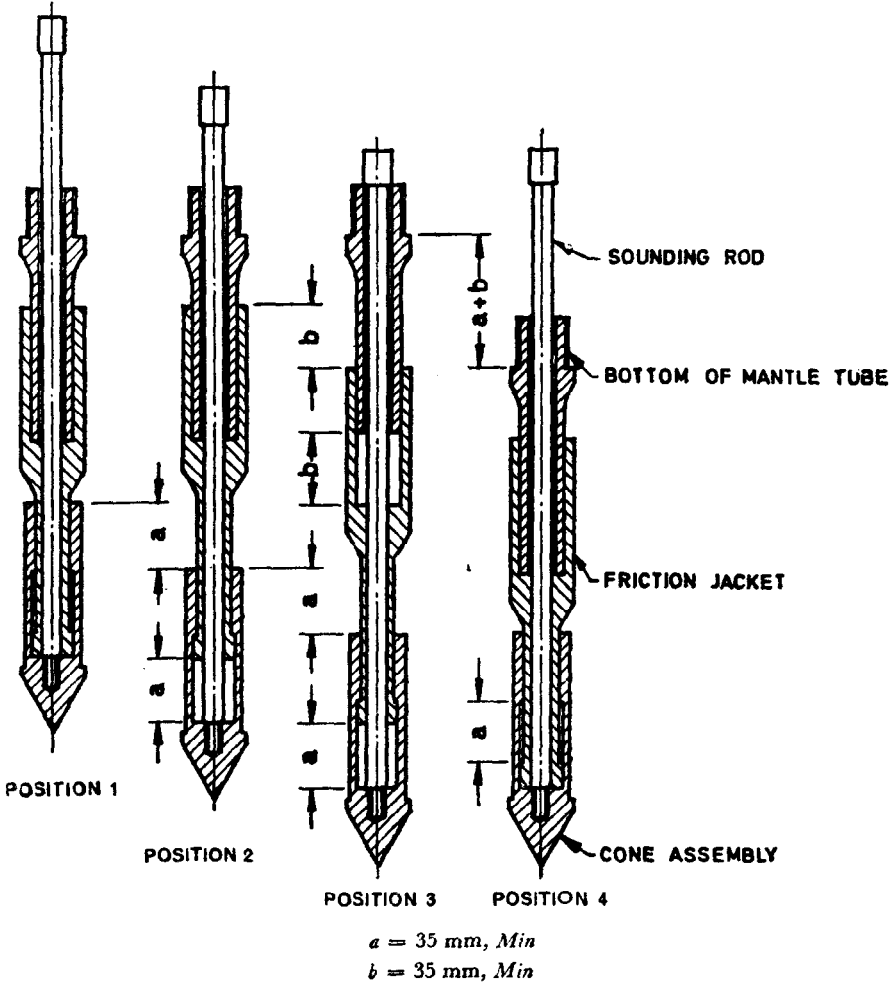

FIG. 5 FOUR POSITIONS OF THE SOUNDING APPARATUS WITH FRICTION JACKET

3.3 The procedure given in 3.2.2 and 3.2.3 should be repeated after pushing the combined cone-friction jacket and mantle tube assembly to the next depth at which the cone and friction resistance values are required. Extension sounding rods and mantle tubes should be added after every one metre of pushing as the test proceeds. Alternatively, the resistances may be determined continuously, if so desired.

3.4 After reaching the deepest point of investigation the entire assembly should be extracted out of the soil by the special operations provided for in the equipment.

4. RECORDS AND CALCULATIONS

4.1 The results of the test shall be tabulated suitably. A recommended pro forma for this purpose with an example is given in Appendix A. The results should also be presented graphically in two graphs, one showing the cone resistance in kN/m^2 (kgf/cm^2) with depth in metres and the other showing friction resistance in kN/m^2 (kgf/cm^2) with depth in metres together with a bore hole log.

4.2 The cone resistance shall be corrected for the dead weight of the cone and sounding rods in use. The combined cone and friction resistance shall be corrected for the dead weight of the cone, friction jacket and sounding rods. These values shall also be corrected for the ratio of ram area to the base area of the cone as illustrated in the example in Appendix A.

5. LIMITATIONS OF THE TEST

5.1 The test is unsuitable for gravelly soils and for soils with standard penetration value N (determined in accordance with IS : 2131-1963*) greater than 50. Also in dense sands the anchorage becomes too cumbersome and expensive and for such cases dynamic cone penetration tests [see IS : 4968 (Part I)-1976† and IS : 4968 (Part II)-1976‡] may be carried out. The test is also unsuitable for made-up or filled-up earth since erroneous values may be obtained due to the presence of loose stones, brick bats, etc. In such places either the made-up soil shall be completely removed to expose the virgin soil layer, or readings in the filled-up depth shall be ignored.

*Method for standard penetration test for soils.

†Method for subsurface sounding for soils: Part I Dynamic method using 50 mm cone without bentonite slurry (first revision).

‡Method for subsurface sounding for soils: Part II Dynamic method using cone and bentonite slurry (first revision).

APPENDIX A

(Clauses 4.1 and 4.2)

PRO FORMA FOR RECORD OF RESULTS OF STATIC
CONE PENETRATION TEST

Projects:	Location of test point:
Site:	Ground elevation:
Bore hole reference:	Ground water level:

Correction: Static cone resistance*

- 1) Mass of cone, $m = 1.1 \text{ kg}^*$
- 2) Mass of each sounding rod, $m_1 = 1.5 \text{ kg}^*$
- 3) Cone area at base, $b = 10 \text{ cm}^2$
- 4) Plunger area (see Note)
- 5) Correction = $(m + nm_1) 10 \text{ kN/m}^2 \dagger$
factor (to be added to the gauge reading) $\left[\frac{m + nm_1}{10} \text{ kgf/cm}^2 \right]$

where

 $n =$ the number of rods in use.

NOTE — If plunger area is 20 cm^2 and base area of cone is 10 cm^2 , the gauge readings should be multiplied by the ratio of the plunger area to the area of the base of the cone, that is 2.

Depth Below Ground Level m	Gauge Reading kN/m^2 (kgf/cm^2)	Corrected Value of Cone Penetration Resistance kN/m^2 (kgf/cm^2)
(1)	(2)	(3)
0.20	2 150 (22.00)	2 176 (22.26)
0.40	900 (9.00)	926 (9.26)
0.60	800 (8.00)	826 (8.26)
0.80	1 000 (10.00)	1 026 (10.26)
1.00	400 (4.00)	426 (4.26)
1.20	500 (5.00)	541 (5.41)
1.40	550 (5.50)	591 (5.91)
1.60	800 (8.00)	841 (8.41)
1.80	450 (4.50)	491 (4.91)

*The figures given in the *pro forma* are by way of example only.

†1kgf has been taken to be approximately equal to 10 Newtons. The exact value is 1 kgf = 9.806 65 N.

Friction resistance measured at particular depths with the help of friction jacket attached to the static cone*

- Correction : 1) Mass of friction jacket = m_f kg
 2) Area of surface of friction jacket, a = πdh cm²

where

d = outer diameter of friction jacket, and
 h = length of friction jacket.

- 3) Cone area at base, $b = 10$ cm²
 4) Correction factor (to be added) = $\frac{100 m_f}{a}$ kN/m² $\left[\frac{m_f}{a} \text{ kgf/cm}^2 \right]$
 = 1 kN/m² (0.01 kgf/cm²)

<i>Depth Below Ground Level</i>	\dagger <i>Total Resistance</i> kN/m ² (kgf/cm ²)	<i>Cone Resistance (Uncorrected)</i> kN/m ² (kgf/cm ²)	<i>Total Resistance Minus Cone Resistance</i> kN/m ² (kgf/cm ²)	<i>Frictional Resistance, z</i> in kN/m ² (kgf/cm ²) $\frac{(x-y)b}{a} = z$	<i>Corrected Frictional Resistance</i> kN/m ² (kgf/cm ²) $z + \frac{100m_f}{a}$ $\left(z + \frac{m_f}{a} \right)$
---------------------------------	---	--	---	---	---

m	x	y	x-y		
(1)	(2)	(3)	(4)	(5)	(6)
2.10	1 250 (13.0)	900 (9.0)	350 (4.0)	24.5 (0.28)	25.5 (0.29)
2.20	1 300 (13.5)	900 (9.0)	400 (4.5)	28.0 (0.32)	29.0 (0.33)
2.30	1 350 (14.0)	1 000 (10.0)	350 (4.0)	24.5 (0.28)	25.5 (0.29)
2.40	1 350 (14.0)	1 000 (10.0)	350 (4.0)	24.5 (0.28)	25.5 (0.29)
2.50	1 400 (14.5)	1 000 (10.5)	400 (4.0)	28.0 (0.28)	29.0 (0.29)
2.60	850 (8.5)	550 (5.5)	300 (3.0)	21.0 (0.21)	22.0 (0.22)
2.70	900 (9.0)	450 (4.5)	450 (4.5)	31.5 (0.32)	32.5 (0.33)
2.80	800 (8.0)	400 (4.0)	400 (4.0)	28.0 (0.28)	29.0 (0.29)
2.90	800 (8.0)	450 (4.5)	350 (3.5)	24.5 (0.25)	25.5 (0.26)

*The figures given in the *pro forma* are by way of example only.

†Total resistance means resistance shown by the gauge due to penetration of cone and friction jacket.

IS : 4968 (Part III) - 1976

(Continued from page 2)

<i>Members</i>	<i>Representing</i>
DR A. BANERJEE	Cementation Co Ltd, Bombay
DR A. K. CHATTERJEE	Public Works Department, Government of Uttar Pradesh
SHRI R. C. DESAI	Rodio Foundation Engineering Ltd; and Hazarat & Co, Bombay
DEPUTY DIRECTOR RESEARCH (FE) (RDSO)	Railway Board (Ministry of Railways)
ASSISTANT DIRECTOR RESEARCH (SOILS) (RDSO) (Alternate)	
DIRECTOR RESEARCH OFFICER (Alternate)	Maharashtra Engineering Research Institute, Nasik
DIRECTOR GENERAL	Geological Survey of India
SHRI S. K. SHOME (Alternate)	
SHRI P. N. MEHTA (Alternate)	
EXECUTIVE ENGINEER (SOIL MECHANICS DIVISION)	Public Works Department, Government of Tamil Nadu
SHRI T. K. NATARAJAN	Central Road Research Institute (CSIR), New Delhi
SHRI H. R. PRAMANIK	River Research Institute, West Bengal
SHRI H. L. SAHA (Alternate)	
REPRESENTATIVE	Hindustan Construction Co Ltd, Bombay
SHRI N. SEN	Roads Wing, Ministry of Shipping & Transport, New Delhi
SHRI P. K. THOMAS (Alternate)	
SUPERINTENDING SURVEYOR OF WORKS (I)	Central Public Works Department, New Delhi
SHRI D. SHARMA	Central Building Research Institute (CSIR), Roorkee
SHRI V. S. AGGARWAL (Alternate)	
SHRI H. C. VERMA	Associated Instruments Manufacturers India Pvt Ltd, New Delhi
PROF T. S. NAGARAJ (Alternate)	

BUREAU OF INDIAN STANDARDS

Headquarters:

Manak Bhavan, 9 Bahadur Shah Zafar Marg, NEW DELHI 110002

Telephones: 331 01 31, 331 13 75

Telegrams: Manaksanstha
(Common to all Offices)

Regional Offices:

	Telephone
Central : Manak Bhavan, 9 Bahadur Shah Zafar Marg, NEW DELHI 110002	{ 331 01 31 331 13 75
*Eastern : 1/14 C. I. T. Scheme VII M, V. I. P. Road, Maniktola, CALCUTTA 700054	36 24 99
Northern : SCO 445-446, Sector 35-C, CHANDIGARH 160036	{ 2 18 43 3 16 41 41 24 42
Southern : C. I. T. Campus, MADRAS 600113	{ 41 25 19 41 29 16
†Western : Manakalaya, E9 MIDC, Marol, Andheri (East), BOMBAY 400093	6 32 92 95

Branch Offices:

'Pushpak', Nurmohamed Shaikh Marg, Khanpur, AHMADABAD 380001	{ 2 63 48 2 63 49
‡Peenya Industrial Area 1st Stage, Bangalore Tumkur Road BANGALORE 560058	{ 38 49 55 38 49 56
Gangotri Complex, 5th Floor, Bhadbhada Road, T. T. Nagar, BHOPAL 462003	6 67 16
Plot No. 82/83, Lewis Road, BHUBANESHWAR 751002	5 36 27
53/5, Ward No. 29, R.G. Barua Road, 5th Byelane, GUWAHATI 781003	3 31 77
5-8-56C L. N. Gupta Marg (Nampally Station Road). HYDERABAD 500001	23 10 83
R14 Yudhister Marg, C Scheme, JAIPUR 302005	{ 6 34 71 6 98 32
117/418 B Sarvodaya Nagar, KANPUR 208005	{ 21 68 76 21 82 92
Patliputra Industrial Estate, PATNA 800013	6 23 05
T.C. No. 14/1421, University P.O., Palayam TRIVANDRUM 695035	{ 6 21 04 6 21 17

Inspection Offices (With Sale Point):

Pushpanjali, First Floor, 205-A West High Court Road, Shankar Nagar Square, NAGPUR 440010	2 51 71
Institution of Engineers (India) Building, 1332 Shivaji Nagar, PUNE 411005	5 24 35

*Sales Office in Calcutta is at 5 Chowringhee Approach, P. O. Princep Street, Calcutta 700072

†Sales Office in Bombay is at Novelty Chambers, Grant Road, 89 65 28
Bombay 400007

‡Sales Office in Bangalore is at Unity Building, Narasimharaja Square, 22 36 71
Bangalore 560002