

IS : 4968 (Part I) - 1976

Indian Standard

METHOD FOR
SUBSURFACE SOUNDING FOR SOILS

**PART I DYNAMIC METHOD USING 50 mm CONE
WITHOUT BENTONITE SLURRY**

(First Revision)

Third Reprint DECEMBER 1994

UDC 624.131.381

© *Copyright* 1977

BUREAU OF INDIAN STANDARDS
MANAK BHAVAN, 9 BAHADUR SHAH ZAFAR MARG
NEW DELHI 110002

*Indian Standard*METHOD FOR
SUBSURFACE SOUNDING FOR SOILSPART I DYNAMIC METHOD USING 50 mm CONE
WITHOUT BENTONITE SLURRY*(First Revision)*

Soil Engineering Sectional Committee, BDC 23

Chairman

PROF DINESH MOHAN

*Representing*Central Building Research Institute (CSIR),
Roorkee*Members*

- ADDITIONAL DIRECTOR RESEARCH Railway Board (Ministry of Railways)
(RDSO)
DEPUTY DIRECTOR RESEARCH
(RDSO) (*Alternate*)
- PROF ALAM SINGH University of Jodhpur, Jodhpur
LT-COL AVTAR SINGH Engineer-in-Chief's Branch, Army Headquarters
MAJ R. R. SUDHINDRA (*Alternate*)
- DR A. BANERJEE Cementation Co Ltd, Calcutta
SHRI S. GUPTA (*Alternate*)
SHRI K. N. DADINA In personal capacity (P-820, 'P', New Alipore,
Calcutta 700053)
- SHRI A. G. DASTIDAR In personal capacity (5, Hungerford Court, 12/1
Hungerford Street, Calcutta 700017)
- SHRI R. L. DEWAN Irrigation Research Institute, Khagaul, Patna
*DR G. S. DHILLON Irrigation Department, Government of Punjab
RESEARCH OFFICER (SOILS)
(IPRI) (*Alternate*)
- SHRI A. H. DIVANJI Rodio Foundation Engineering Ltd; and Hazarat &
Co, Bombay
- SHRI A. N. JANGLE (*Alternate*)
DR SHASHI K. GULHATI Indian Institute of Technology, New Delhi
DR G. V. RAO (*Alternate*)
SHRI V. G. HEGDE National Buildings Organization, New Delhi
SHRI S. H. BALCHANDANI (*Alternate*)

(Continued on page 2)

*Also represents Indian Geotechnical Society, New Delhi

© Copyright 1977

BUREAU OF INDIAN STANDARDS

This publication is protected under the *Indian Copyright Act (XIV of 1957)* and reproduction in whole or in part by any means except with written permission of the publisher shall be deemed to be an infringement of copyright under the said Act.

(Continued from page 1)

<i>Members</i>	<i>Representing</i>
SHRI O. P. MALHOTRA SHRI J. S. MARYA	Public Works Department, Government of Punjab Roads Wing, Ministry of Shipping and Transport, New Delhi
SHRI N. SEN (<i>Alternate</i>) SHRI G. D. MATHUR	Public Works Department, Government of Uttar Pradesh
SHRI D. C. CHATURVEDI (<i>Alternate</i>) SHRI R. S. MELKOTE	Central Water Commission, New Delhi
SHRI C. SUDHINDRA (<i>Alternate</i>) SHRI T. K. NATARAJAN	Central Road Research Institute (CSIR), New Delhi
REPRESENTATIVE RESEARCH OFFICER	Hindustan Construction Co Ltd, Bombay Building and Roads Research Laboratory, Chandigarh
DR K. R. SAXENA SECRETARY	Engineering Research Laboratories, Hyderabad Central Board of Irrigation & Power, New Delhi
DEPUTY SECRETARY (<i>Alternate</i>) *DR SHAMSHER PRAKASH	University of Roorkee, Roorkee
DR GOPAL RANJAN (<i>Alternate</i>) SHRI H. D. SHARMA	Irrigation Research Institute, Roorkee
SUPERINTENDING ENGINEER	Public Works Department, Government of Tamil Nadu
EXECUTIVE ENGINEER (<i>Alternate</i>) SHRI B. T. UNWALLA	Concrete Association of India, Bombay
SHRI T. M. MENON (<i>Alternate</i>) SHRI H. C. VERMA	All India Instruments Manufacturers & Dealers Association, Bombay
SHRI V. K. VASUDEVAN (<i>Alternate</i>) SHRI D. AJITHA SIMHA, Director (Civ Engg)	Director General, ISI (<i>Ex-officio Member</i>)

Secretary

SHRI G. RAMAN
Deputy Director (Civ Engg), ISI

**Site Exploration and Investigation for Foundations
Subcommittee, BDC 23 : 2**

Convener

SHRI R. S. MELKOTE Central Water Commission, New Delhi

Members

SHRI C. SUDHINDRA (*Alternate* to
Shri R. S. Melkote)
PROF ALAM SINGH University of Jodhpur, Jodhpur
LT-COL AVTAR SINGH Engineer-in-Chief's Branch, Army Headquarters
MAJ R. R. SUDHINDRA (*Alternate*)

(Continued on page 9)

*Also represents Institution of Engineers (India), Delhi Centre.

*Indian Standard*METHOD FOR
SUBSURFACE SOUNDING FOR SOILSPART I DYNAMIC METHOD USING 50 mm CONE
WITHOUT BENTONITE SLURRY*(First Revision)*

0. FOREWORD

0.1 This Indian Standard (Part I) (First Revision) was adopted by the Indian Standards Institution on 22 December 1976, after the draft finalized by the Soil Engineering Sectional Committee had been approved by the Civil Engineering Division Council.

0.2 The resistance N_{cd} (*see* Note) to penetration of the cone in terms of number of blows per 300 mm of penetration may be correlated with the bearing capacity of cohesionless soils and also possibly with the load carrying capacity of piles. The correlations are qualitative rather than quantitative in nature and are influenced by the character of the soils, such as grain-size distribution, surcharge pressure, permeability, and degree of saturation. The extra work required to determine the penetration resistance is small compared to the value of the data obtained, but these data only provide a rough indication of the consistency or relative density of the soil.

NOTE — The resistance to penetration in the standard penetration test (IS : 2131-1963*) shall be designated as N , that to a 50 mm cone as N_{cd} and that to a 62.5 mm cone using bentonite slurry as N_{cbr} [IS : 4968 (Part II)-1976†].

0.2.1 Correlation between cone penetration values (N_{cd}) and penetration values obtained by other methods may be developed for a given site by conducting the latter tests adjacent (about 3 to 5 m) to the location of the cone test (*see* Note).

NOTE — However for the 62.5 mm cone driven dry up to a depth of 9 m (without bentonite slurry) [*see* IS : 4968 (Part II)-1976†], for medium to fine sands, the following relationships have been developed by the Central Building Research Institute, Roorkee. These relationships, when utilized, shall be used with caution.

$$N_{cbr} = 1.5 N \text{ up to a depth of 4 m}$$

$$N_{cbr} = 1.75 N \text{ for depths of 4 to 9 m.}$$

*Method for standard penetration test for soils.

†Method for subsurface sounding for soils: Part II Dynamic method using cone and bentonite slurry (*first revision*).

where

N_{cbr} = cone resistance obtained with a 62.5 mm cone driven dry (number of blows for 300 mm penetration); and

N = resistance to penetration in the standard penetration test (in accordance with IS : 2131-1963*), (number of blows for 300 mm penetration).

0.3 This standard was first published in 1968. In this revision several changes have been made taking into consideration the experience gained in conducting the test and in the manufacture of the equipment. The major changes made relate to the material of the cone and the hammer criteria for stopping of driving of the cone and the limitations. Reference has also been made to the automatic arrangement for controlling the drop of the hammer.

0.4 In the formulation of this standard due weightage has been given to international co-ordination among the standards and practices prevailing in different countries in addition to relating it to the practice in the field in this country.

0.5 In reporting the result of a test or analysis made in accordance with this standard, if the final value, observed or calculated, is to be rounded off, it shall be done in accordance with IS : 2-1960†.

1. SCOPE

1.1 This standard covers the procedure for determining the resistance of different soil strata to dynamic penetration of a 50-mm cone and thereby obtaining an indication regarding their relative strengths or density or both. The method helps reconnaissance survey of wide areas in a shorter time which will enable selective *in situ* testing or sampling for typical profile. It can provide useful data for local conditions where reliable correlations have been established.

2. EQUIPMENT

2.1 Cone — The cone with threads (recoverable) shall be of suitable steel with the tip hardened. The cone without threads (expendable) may be of mild steel. The dimensions and shape of the cone shall be as given in Fig. 1A and 1B. For the cone without threads, a cone adapter as shown in Fig. 1C shall be provided.

NOTE — The cone without threads will be left in the ground after the completion of the test.

*Method for standard penetration test for soils.

†Rules for rounding off numerical values (revised).

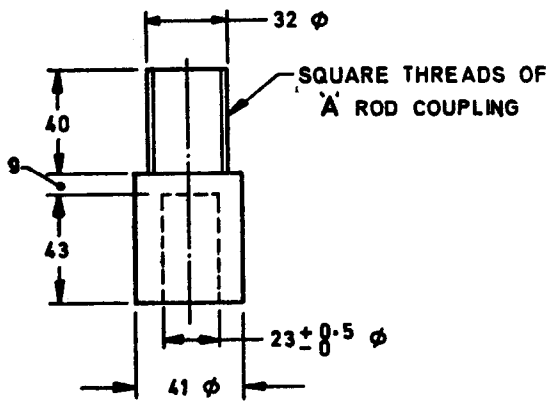
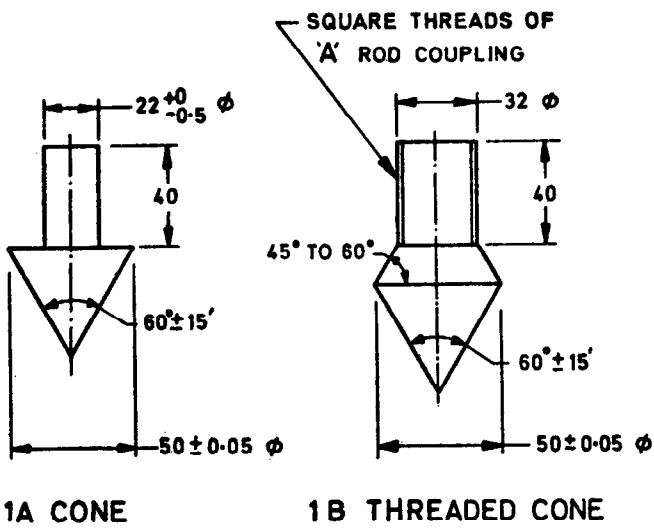

All dimensions in millimetres.

FIG. 1 CONE AND CONE ADOPTER

2.2 Driving Rods — The rods used for the test should be *A* rods of suitable lengths with threads for joining *A* rod coupling at either end. The rods should be marked at every 100 mm.

NOTE — The outer and internal diameters of *A* rods are 41.27 mm and 28.57 mm respectively.

2.3 Driving Head — The driving head shall be of mild steel with threads at either end for a rod coupling (*see* Note under 2.2). It shall have a diameter of 100 mm and a length of 100 to 150 mm.

2.4 Hoisting Equipment — Any suitable hoisting equipment, such as a tripod may be used. The equipment shall be designed to be stable under conditions of impact of the hammer over the driving head when the cone is driven during the test. Provision shall be made to enable the operator to climb up the equipment for fixing the pulley, ropes, etc. A typical set-up using a tripod is shown in Fig. 2. Suitable guides shall be provided to keep the driving rod vertical.

2.5 Hammer — The hammer used for driving the cone shall be of mild steel or cast iron with a base of mild steel. It shall be 250 mm high and of suitable diameter. The weight of the hammer together with the chain shall be 65 kg. It shall have a hole at the centre running throughout its length and of suitable diameter for *A* rod (*see* Note under 2.2) and/or guide to pass freely through it. The clearance between the rod and/or guide and the hole in the hammer shall be about 5 mm.

NOTE — An automatic arrangement for controlling the drop of the hammer may be preferred, if available.

3. PROCEDURE

3.1 The 50 mm diameter 60° cone shall be fitted loosely to the driving rod (*A* rod) (*see* Note under 2.2) through a cone adopter or the threaded cone shall be screwed to the driving rod. The hammer head shall be joined to the other end of the *A* rod with *A* rod coupling. A guide rod 150 cm long shall be connected to the hammer head. This assembly shall be kept vertical, with the cone resting on the ground to be tested. The cone shall then be driven into the soil by allowing the 65 kg hammer to fall freely through a height of 750 mm each time. The number of blows for every 100 mm penetration of the cone shall be recorded. The process shall be repeated till the cone is driven to the required depth (*see* Note and 4.1).

NOTE — To save the equipment from damage, driving may be stopped when the number of blows exceeds 35 for 100 mm penetration.

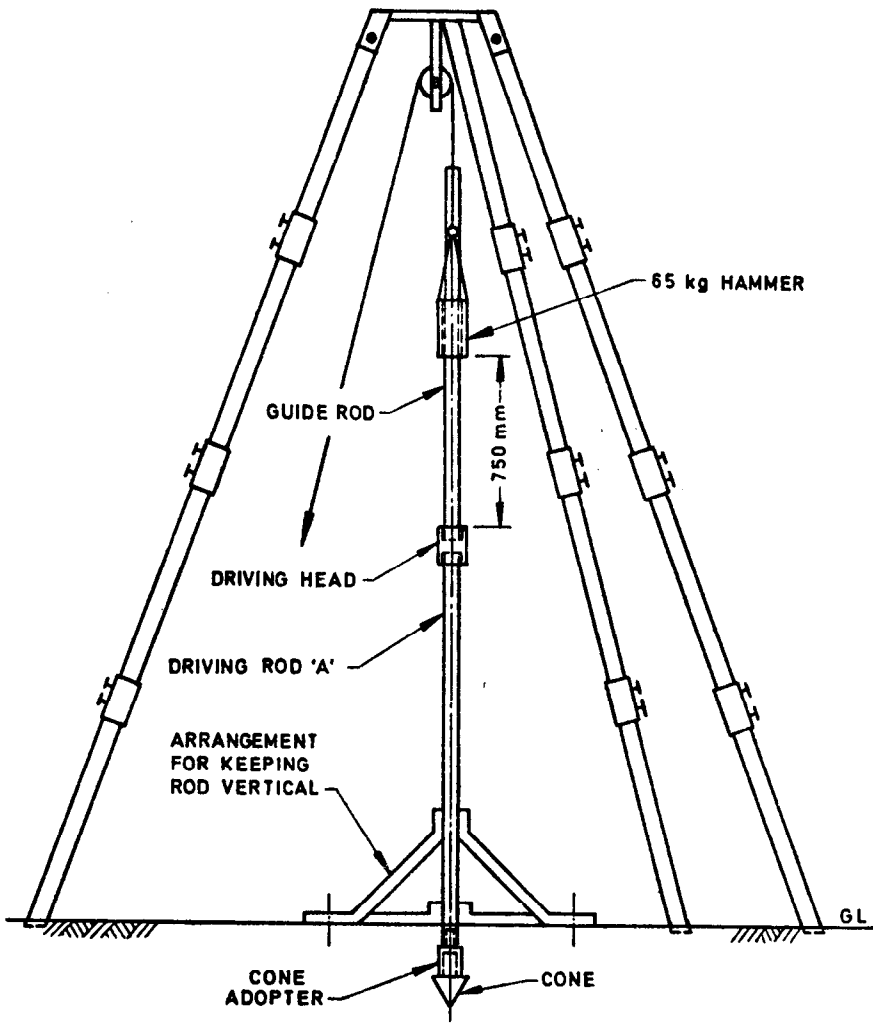

FIG. 2 TYPICAL ASSEMBLY OF EQUIPMENT FOR CONE PENETRATION TEST

4. LIMITATIONS

4.1 The maximum depth to which the cone should be driven will depend upon the type of soil, the position of the water table and the purpose of the test. If correlations of cone penetration values obtained by other methods is desired in interpretation, in cohesionless soils the depth may be limited to 5 m; in mixed soil with some binding material the depth may be 10 m. If the test is used for obtaining a general qualitative idea of the strata, the cone may be driven to any convenient depth.

5. REPORT

5.1 The number of blows (N_{cd}) as a continuous record for every 300 mm of penetration shall be shown in a tabular statement or shown as a graph between N_{cd} and depth. Records of the test shall also include the following:

- a) Date of probing;
- b) Location;
- c) Elevation of ground surface;
- d) Depth of water table and its likely variation, from available information;
- e) Total resistance at the required levels;
- f) Any interruption in probing, with reasons;
- g) Any other information available, for example, type of soil; and
- h) Diameter of the cone used in the test.

(Continued from page 2)

Members

Representing

DR A. BANERJEE	Cementation Co Ltd, Bombay
DR A. K. CHATTERJEE	Public Works Department, Government of Uttar Pradesh
SHRI R. C. DESAI	Rodio Foundation Engineering Ltd; and Hazarat & Co, Bombay
DEPUTY DIRECTOR RESEARCH (FE) (RDSO)	Railway Board (Ministry of Railways)
ASSISTANT DIRECTOR RESEARCH (SOILS) (RDSO) (Alternate)	
DIRECTOR RESEARCH OFFICER (Alternate)	Maharashtra Engineering Research Institute, Nasik
DIRECTOR GENERAL SHRI S. K. SHOME (Alternate)	Geological Survey of India
SHRI P. N. MEHTA (Alternate)	
EXECUTIVE ENGINEER (SOIL MECHANICS DIVISION)	Public Works Department, Government of Tamil Nadu.
SHRI T. K. NATARAJAN	Central Road Research Institute (CSIR), New Delhi
SHRI H. R. PRAMANIK	River Research Institute, West Bengal
SHRI H. L. SAHA (Alternate)	
REPRESENTATIVE SHRI N. SEN	Hindustan Construction Co Ltd, Bombay Roads Wing, Ministry of Shipping & Transport, New Delhi
SHRI P. K. THOMAS (Alternate)	
SUPERINTENDING SURVEYOR OF WORKS (I)	Central Public Works Department, New Delhi
SHRI D. SHARMA	Central Building Research Institute (CSIR), Roorkee
SHRI V. S. AGGARWAL (Alternate)	
SHRI H. C. VERMA	Associated Instruments Manufacturers India Pvt Ltd, New Delhi
PROF T. S. NAGARAJ (Alternate)	

BUREAU OF INDIAN STANDARDS

Headquarters:

Manak Bhavan, 9 Bahadur Shah Zafar Marg, NEW DELHI 110002

Telephones: 331 01 31, 331 13 75

Telegrams: Manaksanstha
(Common to all Offices)

Regional Offices:

Telephone

Central : Manak Bhavan, 9 Bahadur Shah Zafar Marg, NEW DELHI 110002	{ 331 01 31 331 13 75
*Eastern : 1/14 C. I. T. Scheme VII M, V. I. P. Road, Maniktola, CALCUTTA 700054	{ 36 24 99
Northern : SCO 445-446, Sector 35-C, CHANDIGARH 160036	{ 2 18 43 3 16 41
Southern : C. I. T. Campus, MADRAS 600113	{ 41 24 42 41 25 19 41 29 16
†Western : Manakalaya, E9 MIDC, Marol, Andheri (East), BOMBAY 400093	{ 6 32 92 95

Branch Offices:

'Pushpak', Nurmohamed Shaikh Marg, Khanpur, AHMADABAD 380001	{ 2 63 48 2 63 49
‡Peenya Industrial Area 1st Stage, Bangalore Tumkur Road BANGALORE 560058	{ 38 49 55 38 49 56
Gangotri Complex, 5th Floor, Bhadbhada Road, T. T. Nagar, BHOPAL 462003	{ 6 67 16
Plot No. 82/83, Lewis Road, BHUBANESHWAR 751002	{ 5 36 27
53/5, Ward No. 29, R.G. Barua Road, 5th Byelane, GUWAHATI 781003	{ 3 31 77
5-8-56C L. N. Gupta Marg (Nampally Station Road), HYDERABAD 500001	{ 23 10 83
R14 Yudhister Marg, C Scheme, JAIPUR 302005	{ 6 34 71 6 98 32
117/418 B Sarvodaya Nagar, KANPUR 208005	{ 21 68 76 21 82 92
Patliputra Industrial Estate, PATNA 800013	{ 6 23 05
T.C. No. 14/1421. University P.O., Palayam TRIVANDRUM 695035	{ 6 21 04 6 21 17

Inspection Offices (With Sale Point):

Pushpanjali, First Floor, 205-A West High Court Road, Shankar Nagar Square, NAGPUR 440010	{ 2 51 71
Institution of Engineers (India) Building, 1332 Shivaji Nagar, PUNE 411005	{ 5 24 35

*Sales Office in Calcutta is at 5 Chowringhee Approach, P. O. Princep Street, Calcutta 700072

†Sales Office in Bombay is at Novelty Chambers, Grant Road, Bombay 400007

‡Sales Office in Bangalore is at Unity Building, Narasimharaja Square, Bangalore 560002

Reprography Unit, BIS, New Delhi, India

TO

IS:4968(Part 1)-1976 METHOD FOR SUBSURFACE
SOUNDING FOR SOILS

PART 1 DYNAMIC METHOD USING 50 mm CONE WITHOUT
BENTONITE SLURRY

(First Revision)

(Pages 3 and 4) - Substitute 'IS:2131-1981'
for 'IS:2131-1963'.

(Pages 3 and 4, footnote with '*' mark) -
Substitute the following for the existing footnote:

'*Method of standard penetration test for soils
(first revision).'

(Pages 4 to 6, clause 2) - Substitute the
following for the existing clause:

"2. EQUIPMENT

2.1 The cone driving rods, driving head, hoisting
equipment shall conform to IS:10589-1983
'Specification for equipment for determination of
subsurface sounding of soils'."

(Pages 5 and 7) - Delete Fig. 1 and 2.

(BDC 23)

Reprography Unit, BIS, New Delhi, India