

IS : 4880 (Part V) - 1972

Indian Standard (Reaffirmed 1995)

**CODE OF PRACTICE FOR
DESIGN OF TUNNELS CONVEYING WATER
PART V STRUCTURAL DESIGN OF CONCRETE LINING
IN SOFT STRATA AND SOILS**

(Second Reprint NOVEMBER 1990)

UDC 624.191.1 : 624.196

© Copyright 1972

**BUREAU OF INDIAN STANDARDS
MANAK BHAVAN, 9 BAHADUR SHAH ZAFAR MARG
NEW DELHI 110002**

Gr 7

December 1972

Indian Standard

CODE OF PRACTICE FOR DESIGN OF TUNNELS CONVEYING WATER

PART V STRUCTURAL DESIGN OF CONCRETE LINING IN SOFT STRATA AND SOILS

Water Conductor Systems Sectional Committee, BDC 58

Chairman

SHRI P. M. MANE
Ramalayam, Pedder Road,
Bombay 26

Members

SHRI K. BASANNA
SHRI N. M. CHAKRAVORTY
CHIEF CONSTRUCTION ENGINEER
SUPERINTENDING ENGINEER
(TECHNICAL/CIVIL) (*Alternate*)
CHIEF ENGINEER (CIVIL)
SUPERINTENDING ENGINEER
(CIVIL AND INVESTIGATION
CIRCLE) (*Alternate*)
CHIEF ENGINEER (CIVIL)
CHIEF ENGINEER (IRRIGATION)

SHRI J. WALTER (*Alternate*)
DIRECTOR (H C D)
DEPUTY DIRECTOR (PH-1) (*Alternate*)
DIRECTOR, LRIPRI

SHRI H. L. SHARMA (*Alternate*)

SHRI D. N. DUTTA

SHRI O. P. DATTA

SHRI J. S. SINGHOTA (*Alternate*)

SHRI R. G. GANDHI

SHRI M. S. DEWAN (*Alternate*)

SHRI K. C. GHOSAL

SHRI A. K. BISWAS (*Alternate*)

SHRI M. S. JAIN

SHRI I. P. KAPILA

Representing

Public Works Department, Government of **Mysore**
Damodar Valley Corporation, Dhanbad
Tamil Nadu Electricity Board, Madras

Andhra Pradesh State Electricity Board, **Hyderabad**

Kerala State Electricity Board, Trivandrum
Public Works Department, Government of Tamil
Nadu

Central Water & Power Commission, New Delhi

Irrigation & Power Department, Government of
Punjab

Assam State Electricity Board, Shillong

Beas Designs Organization, Nangal Township

The **Hindustan** Construction Co Ltd, Bombay

Alokudyog Cement Service, New Delhi

Geological Survey of India, Calcutta

Central Board of Irrigation & Power, New Delhi

(Continued on *page 2*)

BUREAU OF INDIAN STANDARDS

MANAK BHAVAN, 9 BAHADUR SHAH ZAFAR MARG

NEW DELHI 110002

IS : 4880 (Part V) - 1972

(Continued from page 1)

<i>Members</i>	<i>Representing</i>
SHRI B. S. KAPRE	Irrigation & Power Department, Government of Maharashtra
SHRI Y. G. PATEL	Patel Engineering Co Ltd, Bombay
SHRI C. K. CHOKSHI (Alternate)	
SHRI A. R. RAICHUR	R. J. Shah & Co Ltd, Bombay
SHRI S. RAMCWANDRAN	National Projects Construction Corporation Ltd, New Delhi
SHRI K. N. TANEJA (Alternate)	
SHRI G. N. TANDON	Irrigation Department, Government of Uttar Pradesh
SHRI D. AJITHA SIMHA, Director (Civ Engg)	Director General, ISI (Ex-officio Member)

Secretary

SHRI G. RAMAN
Deputy Director (Civ Engg), ISI

Panel for Design of Tunnels, BDC 58:P1

<i>Convener</i>	
SHRI C. K. CHOKSHI	Patel Engineering Co Ltd, Bombay
<i>Members</i>	
CHIEF ENGINEER (IRRIGATION)	Public Works Department, Government of Tamil Nadu
DIRECTOR (HCD)	Central Water & Power Commission, New Delhi
DEPUTY DIRECTOR (PH-1) (Alternate)	
SHRI O. P. GUPTA	Irrigation Department, Government of Uttar Pradesh
SHRI M. S. JAIN	Geological Survey of India, Calcutta
SHRI B. S. KAPRE	Irrigation & Power Department, Government of Maharashtra
SHRI A. R. RAICHUR	R. J. Shah & Co Ltd, Bombay
SHRI J. S. SINGHOTA	Beas Designs Organization, Nangal Township
SHRI O. R. MEHTA (Alternate)	

Indian Standard

CODE OF PRACTICE FOR DESIGN OF TUNNELS CONVEYING WATER

PART V STRUCTURAL DESIGN OF CONCRETE LINING IN SOFT STRATA AND SOILS

0 . F O R E W O R D

0.1 This Indian Standard (Part V) was adopted by the Indian Standards Institution on 25 February 1972, after the draft finalized by the Water Conductor Systems Sectional Committee had been approved by the Civil Engineering Division Council.

0.2 Water conductor system occasionally takes the form of tunnels through high ground or mountains, in rugged terrain where the cost of surface pipe line or canal is excessive and elsewhere as convenience and economy dictates. This standard, which is being published in parts, is intended to help the engineers in design of tunnels conveying water. This part lays down the criteria for structural design of concrete lining for tunnels in soft strata and soils, covering recommended methods of design. However, in view of the complex nature of the subject, it is not possible to cover each and every possible situation in the standard and many times a departure from the practice recommended in this standard may be necessary to meet the requirements of a project' and/or site for which discretion of the designer would be required. Some such situations in which special investigations will be required are given below:

- a) Where swelling and squeezing types of rocks subject to internal tectonic stresses are met;
- b) Where high temperature carbonate formations are met, which may produce carbon dioxide;
- c) Where large variations in formation temperatures exist in different sections of a tunnel; and
- d) Where anhydrite formations are met which may show expansion sometimes about 30 percent of their volume on becoming wet,

0.3 Other parts of this standard are as follows:

- Part I General design,
- Part II Geometric design,
- Part III Hydraulic design,

IS : 4880 (Part V) - 1972

Part IV Structural design of concrete lining in rock, and

Part VI Tunnel supports.

0.4 For the purpose of deciding whether a particular requirement of this standard is complied with, the final value, observed or calculated, expressing the result of a test or analysis, shall be rounded off in accordance with IS : 2-1960*. The number of significant places retained in the rounded off values should be the same as that of the specified value in this standard,

1. SCOPE

1.1 This standard (Part V) covers the criteria for structural design of plain and reinforced concrete lining for tunnels and shafts in soft strata and soils mainly for river valley projects.

NOTE -The provisions may, nevertheless, be used for design of tunnels for roadways, railways, sewage and water supply schemes! provided that all factors peculiar to such projects as may affect the design are taken into consideration.

1.2 This standard, however, does not cover the design of steel and prestressed concrete lining, the design for concrete lining in swelling and squeezing rocks subject to internal tectonic stresses and design for seismic forces.

2. TERMINOLOGY

2.0 For the purpose of this standard the following definitions shall apply.

2.1 Soft Strata — Strata of rocks which are soft either by their nature, usually sedimentary and metamorphic or which have become soft due to alternation and/or shearing, crushing and intensive jointing and which require supports to be installed within a very short period of excavation, but which cannot be easily excavated by hand tools.

2.2 Soils — Decomposed and disintegrated rocks which require support immediately after and/or during excavation and can be excavated by hand, tools.

2.3 Minimum Excavation Line (A-Line) -A line within which no unexcavated material of any kind and no supports other than permanent structural steel supports shall be permitted to remain.

NOTE — Where due to the nature of strata structural steel supports are essential the minimum excavation line may be at least 75 mm behind the outer flange of the support to accommodate permanent lagging and/or primary-concrete.

*Rules for rounding off numerical values(*revised*).

IS : 4880 (Part V). 1972

2.4 Pay Line (B-Line) — An assumed line (beyond A-line) denoting mean line to which payment of excavation and concrete lining is made whether the actual excavation falls inside or outside it.

NOTE — The distance between A and B-lines shall be decided by contracting authority.

2.5 Primary Lining — A concrete lining laid immediately after excavation and installation of steel supports. This may cover the full section excavated or part section depending on conditions of strata. This may be plain *in situ* concrete or precast concrete segment; or cast iron segments packed with concrete or grout.

2.6 Final Lining — It is the concrete between primary lining and the finished line of the tunnel.

2.7 Cover — Cover on a tunnel in any direction is the distance from the tunnel profile to the ground surface in that direction. However, where the thickness of the overburden is sizable its equivalent weight may also be reckoned provided that the rock cover is more than three times the diameter of the tunnel.

3. MATERIALS

3.1 Plain and reinforced concrete shall generally conform to IS : 456-1964*.

4. GENERAL

4.1 The design of tunnel linings requires a thorough study of the geology of the strata to be pierced by the tunnel, the effective cover and a knowledge of the stress strain characteristics, state of stress, etc. It is recommended that a critical study of all these factors be made by test borings, drifts, pilot tunnels or other exploratory techniques. The design of tunnel linings also requires a critical study of the external and internal loading conditions, stresses prior to excavation and their redistribution after excavation. On account of anisotropy of strata and other variables and indeterminate factors, the designer should make a reasonable assessment of the loading conditions taking all the factors into consideration. In soft strata tunnels, besides the above data, it is essential for the designer to have a knowledge of the method of construction which is practicable and economical. The development of loads, in soft strata, is dependent on the size and shape of the tunnel and the methods of construction and time lag between excavation and support. The design should aim at simplicity of construction.

4.2 It is essential for the designer to have a fairly accurate idea of the seepage and the presence or absence of ground water under pressure likely

*Code of practice for plain and reinforced concrete (second revision).

to be met with. Where heavy seepage of water is anticipated, the designer shall make provisions for grouting with cement and/or chemicals or extra drainage holes and also consider the feasibility of providing steel lining, if necessary. It is recommended that such designs of alternative use of steel lining be made with the design of plain-reinforced lining, so that the design is readily available should the construction personnel require it, when they meet unanticipated conditions.

4.3 Pressure tunnels with high hydrostatic loads shall have concrete lining reinforced sufficiently to withstand bursting, where inadequate rock cover and unstable ground conditions prevail. Generally, a pressure tunnel should have a reinforced lining if the cover is less than the internal pressure head. In such cases even the provision of a steel plate liner should be considered. If reinforced concrete lining is adopted, the stresses in reinforcement shall be checked to avoid excessive crack width in the concrete as these may lead to seepage from the tunnel into the strata endangering its stability. The final choice would, however, be guided by the geological set up, practicability and economics. The provision of steel liner shall also be considered where high velocity cavitation or erosion of the lining is expected due to high velocity of water.

4.4 Detailed structural analysis and model studies shall be made for design of junctions and transitions for tunnels. Such transitions are difficult to construct in the restricted working space in tunnels and this aspect shall be kept in view so that the proposed structures are easy for construction.

4.5 An adequate amount of both longitudinal and circumferential reinforcement may be provided near the portals of tunnels to resist loads resulting from loosened rock headings or from sloughing of portal cuts. The length to which such reinforcement should be provided depends on the nature of the rock (extent of disintegration, stratification, etc) and the nature and probable behaviour of the overburden near the portal face.

5. LOADING CONDITIONS

5.1 General — The design shall be based on the most adverse combination of probable load conditions, but shall include only those loads which have reasonable probability of simultaneous occurrence.

5.2 Load Conditions — The design loading applicable to tunnel linings shall be classified as normal and extreme design loading conditions. Design shall be made for normal loading conditions (see Appendix A). The design loading shall be as follows:

- a) *External Strata Loads (see 7.7)*
- b) *Self Load of Lining*
- c) *External Water Pressure*

1) *Normal design loading conditions* — The maximum loading obtained from either maximum steady or steady state

condition with loading equal to normal maximum ground water pressure and no internal pressure, or maximum difference in levels between hydraulic gradient in the tunnel, under steady state or static conditions and the maximum downsurge under normal transient operation.

- 2) *Extreme design loading conditions*—Loading equal to the maximum difference in levels between the hydraulic gradient in the tunnel under static conditions and the maximum downsurge under extreme transient operation or the difference between the hydraulic gradient and the tunnel invert level in case of tunnel empty conditions.

d) *Internal Design Water Pressure (see 7.9)*

- 1) *Normal design loading conditions* — Maximum static conditions corresponding to maximum water level in the head pond, or loading equal to the difference in levels between the maximum upsurge occurring under normal transient operation and the tunnel centre line.
- 2) *Extreme design loading conditions* — Loading equal to the difference between the highest level of hydraulic gradient in the tunnel under emergency transient operation and the tunnel centre line.

e) *Seismic Forces* — See Note.

NOTE—According to the prevailing practice the tunnel lining is not designed for seismic forces unless the tunnel crosses an active fault in which case some flexibility is provided at that section to allow for some movement in case of an earthquake. However, at locations where studies indicate that seismic forces will be significant they shall be catered for in the design.

5.3 Design Loading for Shafts — The design loading for the shaft walls shall in general be the external earth and ground water pressures. The earth pressure will vary according to the material through which the shaft is excavated and may be computed from the Rankine, Coulomb or slip circle theories in the same way as for retaining walls. This may be considered as uniformly distributed along the perimeter of the shaft except where the material changes in its properties such as in case of steep sloping rock overlain by overburden in which case the differential pressures should be suitably reckoned.

5.3.1 If compressed air sinking is applied, force due to this aspect shall also be taken into account.

5.3.2 If a mantle of thixotropic fluid is used between the walls of shaft and the surrounding soil the resulting reduction in the frictional and external earth pressures with full hydrostatic pressure may be accounted for,

IS : 4880 (Part V) - 1972

5.3.3 The shaft wall shall also be dimensioned against the axial stresses for tension and bending likely to be encountered during the course of uneven or sudden sinking.

5.3.4 For preliminary estimating the wall thickness may be assumed to be equal to about 8 percent of the shaft diameter.

5.3.5 Circular shafts are preferable as the most straight forward. If other sections (e.g. rectangular) are selected for other considerations, they shall be dealt with as closed frame and corners rounded suitably to reduce concentration of stresses.

5.4 The loading conditions vary from construction stage to operation stage and from operation stage to maintenance stage. The design shall be checked for all probable combinations of loading conditions likely to come on it during all the above stages.

6. STRESSES

6.1 For design of final concrete lining, the thickness of concrete up to A-line shall be considered. Concrete placed as primary concrete will be neglected in the design and its strength can be less than the strength specified for the final lining. The stresses, for concrete and reinforcement shall be in accordance with IS : 456-1964* for design of lining for normal load conditions and shall be increased by $33\frac{1}{3}$ percent for extreme load conditions.

7. DESIGN

7.1 The design of concrete lining of tunnel can only be an intelligent provision for catering to unknown forces and reactions and support conditions. Until reliable data on behaviour of lining is obtained, it is recommended to use approximate methods.

7.2 The elastic behaviour (including flexibility) of the tunnel supports and the primary lining shall be taken into account while designing the lining.

7.3 Design of steel supports, assisted by primary concrete, shall cater for external loads that will develop before final lining is placed. The final lining shall cater for the loads likely to develop after placing of the primary lining and when the work is in operation.

7.4 While designing the final lining the fact that the primary lining and the steel support will also participate in resisting the forces, shall be taken into consideration.

NOTE -To ensure this condition of support the gap between the strata and lining shall be fully closed by grouting and the rock around the tunnel for a distance of at least one diameter shall be strengthened by grouting under pressure.

*Code of practice for plain and reinforced concrete (*second* revision),

7.5 In the case of granular soils and clays, the external load will be taken by the steel supports and primary concrete fully. This lining shall be designed using methods similar to design of culverts on soils. The height of overburden may be the height as calculated by the formula given in Appendix B.

NOTE -It is essential that the gap between strata and the support lining is fully backfilled and grouted at a pressure. not exceeding 2 kg/cm* immediately after the supports and lining are placed,

7.6 The thickness of the lining shall be designed such that the stresses in it are within permissible limits when the most adverse load conditions occur. The minimum thickness of the lining will, however, be governed by requirements of construction. It is recommended that the minimum thickness of plain concrete lining should be 15 cm for manual placement. Where mechanical placement is contemplated the thickness. of the lining at the crown shall be such that the slick line may be easily introduced on the top of the shutter without being obstructed by steel supports. For a 15 cm slick line a clear space of 18 cm is recommended. For reinforced concrete lining, a minimum thickness of 30 cm at the crown is recommended, the reinforcement, however, being arranged in the crown to allow for proper placement of slick line.

7.6.1 For preliminary designs, the thickness of lining may be assumed to be 6 **cm/m** of the finished diameter of the tunnel in the case of **soft** strata and 12 **cm/m** of finished diameter in the case of soils.

7.6.2 Where structural steel supports are used, they shall be considered as reinforcement only, if they can be made effective as reinforcement by use of high tensile bolts/at the joints and/or by proper welding of the joints. A minimum cover of 15 cm shall be provided over the inner flange of steel supports and a minimum cover of 8 cm over the reinforcement bars,

7.7 External Loads from Strata— The determination of the magnitude of the rock load on the supporting structures of the tunnel is a complex problem. This complexity is due to the inherent difficulty of predicting the primary stress conditions in the strata (prior to excavation), and also due to the fact that the magnitude of the secondary pressures developing after the excavation of the cavity, depend on a large number of variables, such as size of cavity, method of excavation, period of time elapsing before the strata is supported, the rigidity of supports, deformation modulus of the surrounding strata, etc.

7.7.1 Secondary external pressure, in general, is understood as the weight of the mass of strata some height above the tunnel which when left unsupported would gradually drop out of the roof. This pressure may develop not only immediately after excavation, but also over period of time after excavation due to adjustment of displacements, in the strata. The

IS : 4880 (Part V) - 1972

loads are carried both by the tunnel lining and the surrounding strata and this fact shall be considered in design.

7.7.1.1 In the case of granular soils, the loads and side pressures are influenced by the **physical** properties of the soils. In clays, the water content and plasticity of the clays also affects the pressures on the tunnel linings.

7.7.1.2 In the absence of any data and investigations, it is **recommended** that the rock loads may be assumed to be acting as uniformly distributed loads and the magnitude assumed as indicated in Appendix B.

7.7.2 *External Pressure of Water* -The lining shall be designed for external water pressure, if any (see 5.2).

7.7.3 *Self Weight of Lining* -The lining will be in close contact with the strata and its weight is distributed over the periphery by frictional forces. However, the weight shall be considered as a uniformly distributed load on the invert (lower half) of the section.

7.7.4 *Weight of Water Contained in the Tunnel* — This shall be considered only for tunnels in soft strata and soils.

7.7.5 *Superimposed Live Loads* -These do not materially affect the tunnels in soft strata- where the diameter of the tunnel is small and the depth of overburden is large. In case of tunnels where the overburden is less, full superimposed load on the basis of normal distribution of loads in foundation strata should be considered in addition to the overburden loads on the tunnel.

NOTE — It may be said that negligible load is transmitted at a depth of more than 3 times the width of the structure causing the superimposed load.

7.7.6 *Side Thrusts or Pressures, Active or Passive* — In the case of tunnels in soft strata, side pressures may exist. The magnitude of these pressures may be estimated on lines similar to the procedure for soils. In case of soils the side pressures may be taken as proportional to the vertical pressures and may be determined by classical theories of soil mechanics. The passive pressures will develop only when there is a deformation. In soft strata and soils, for tunnels constructed with due precautions of grouting around the periphery ensuring a close contact, the passive pressures may be relied upon to bring about a re-distribution of loads.

7.8 Since continuous contact is assumed to be established due to grouting, the strata around and lining both will act and share the loads and deformations. Passive pressures may be assumed to be called into play and considered in design.

7.8.1 In the case of tunnels in soft strata and soil, the moments and thrusts may be calculated as indicated in Table 1.

NOTE — The same theory is used for design of culverts.

TABLE 1 CALCULATION OF MOMENTS AND THRUSTS IN CIRCULAR CULVERTS IN SOIL FOR $\alpha' = 90^\circ$
(Clause 7.8.1)

Sl. No.	LOADING CONDITION	MOMENT = M NORMAL FORCE = N	$\alpha = 0^\circ$ (CROWN BEDDING*)		$\alpha = 45^\circ$ (QUARTER POINT BEDDING*)		$\alpha = 90^\circ$ (SPRINGING BEDDING*)		$\alpha = 135^\circ$ (QUARTER POINT BEDDING*)		$\alpha = 180^\circ$ (BOTTOM BEDDING*)	
			I	II	I	II	I	II	I	II	I	II
			i) Dead load	M/pr^2 N/pr	+0.3448 -0.1667	+0.2725 0	+0.0335 +0.4375	+0.0100 +0.5554	-0.03927 +1.5708	-0.2983 +1.5708	-0.0355 +1.1334	+0.0100 +1.9696
ii) Internal water pressure	$M/\gamma_w r^3$ $N/\gamma_w r^2$	+0.1724 -0.5833	-0.1363 -0.5000	+0.0168 -0.4277	+0.0050 -0.3687	-0.1964 -0.2146	-0.1492 -0.2146	-0.0168 -0.7868	+0.1363 -0.3687	+0.0050 -1.4147	+0.1363 -0.5000	
iii) External water pressure	$M/\gamma_w r^3$ $N/\gamma_w r^2$	+0.2203 +0.5833	+0.1363 +1.5000	+0.0168 +1.2131	+0.0050 +1.6313	-0.1964 -1.7854	-0.1492 +1.7854	+0.0168 +1.5723	+0.0050 +1.6313	+0.1724 +1.4167	+0.1363 +1.5000	
iv) Excess water pressure in conduit	M	$(P_b - P_k) r_b r_k \left[\frac{1}{2} - \frac{r_b r_k}{r^2 - r_b^2} \ln \frac{r_k}{r_b} \right]$ throughout the entire ring										
	N	$-P_b r_b$ or $+P_k r_k$ throughout the entire ring										
v) Uniformly distributed vertical earth pressure	$M/\gamma' r^2 t$ $N/\gamma' r t$	0.2500 0	0.2273 0.0530	0.5000 0	-0.0072 0.5375	-0.2500 1.0000	-0.2197 1.00	0 0.500	0.0141 0.7662	0.2500 0	0.1967 0.5836	
vi) Horizontal earth pressure trapezoidal distribution	$M/\gamma' \lambda_a r^3$ $N/\gamma' \lambda_a r^2$	$(-0.2500t + 0.00417r)$ $(t - 0.375r)$		$(0 - 0.295r)$ $(0.5t - 0.0884r)$		$(0.2500t + 0)$ 0		$(0 + 0.0295r)$ $(0.500t + 0.884r)$		$(-0.2500t - 0.0417r)$ $(t + 0.3750r)$		
vii) Uniformly distributed horizontal earth pressure	$M/\gamma' \lambda_a r^3 t$ $N/\gamma' \lambda_a r^2 t$	0.25 1.00	0.25 1.00	0 0.50	0 0.50	0.25 0	0.25 0	0 0.50	0 0.50	-0.25 1.00	-0.25 1.00	

NOTE 1 -The above formulae for both bedding conditions were also derived by Marquardt for the case of partial embedment.

NOTE 2 - $\gamma' =$ density of soil

$$\lambda_a = \tan^2(45^\circ - \phi/2)$$

$\rho =$ density of concrete

*Please see Figures for Bedding Conditions I and II.

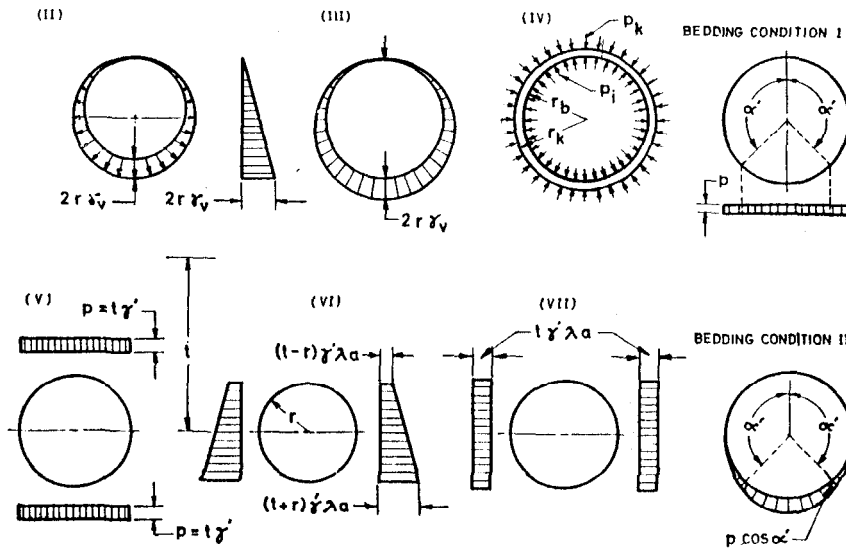

As in the Original Standard, this Page is Intentionally Left Blank

7.8.2 For non-circular lining, it would be necessary to conduct model tests to determine the stress distributions. However, the design may be done assuming uniformly distributed loads as in the case of circular tunnels, and using the same distribution for passive pressures. The design of such indeterminate sections may be done by accepted methods and is not covered by this standard.

7.9 Design for Internal Waterpressure-The design for internal water pressure shall be done by considering the lining and surrounding strata, if the strata after grouting is capable of sustaining a part of the internal pressure as a composite thick cylinder. In such a design, the primary concrete may be treated as a part of the thick cylinder.

NOTE-This method suffers from uncertainties of external loads, material properties and indeterminate tectonic forces. In this method the strata surrounding the tunnels is assumed to have reasonably uniform characteristics and strength and that effective pressure grouting has been done to validate the assumption that concrete lining and surrounding strata behave as a composite cylinder. The grout fills the cracks and voids in the strata and thus reduces its ability to deform inelastically and increases the modulus of deformation. If the grout pressures are high enough to cause sufficient **prestressing** in the lining the effect of temperature and drying shrinkage and **inelastic** deformation might be completely counteracted.

7.9.1 For analyzing a circular lining the method given in Appendix C may be adopted. The design shall be such that at no point in the lining and the surrounding rock the stresses exceed the permissible limits.

NOTE — If the rock is not good, tensile stress in concrete may exceed the allowable limit and in such a case, reinforcement may be provided. Reinforcement, however, is not capable of reducing the tensile stresses to a considerable extent. By suitable arrangement, it will help to distribute the cracks on the whole periphery in the form of hair cracks which are not harmful because they may get closed in course of time, or at least they will not result in serious leakage.

7.9.2 For analyzing non-circular linings, the stress pattern may be determined by photo-elastic studies.

8. GROUND WATER DRAINAGE HOLES

8.1 Drainage holes may be often provided in other than water conveying tunnels to relieve external pressure, if any, caused by seepage along the outside of the tunnel lining. It is recommended that drainage holes may be spaced at 6-m centres, at intermediate locations between the grout rings. At successive sections, one vertical hole may be drilled near the crown alternating with two drilled horizontal holes, one in each side wall. Drainage holes shall extend to a minimum of 15 cm beyond the back of the lining or grouted zone. Where suitable, drains encased in suitable graded material, running along the tunnel may be provided by the sides of invert lining with provision of weep holes opening into the tunnel.

8.1.1 In free flowing tunnels drainage holes may be provided above the full supply level. In the case of pressure tunnels, if external water

IS : 4880 (Part V) - 1972

pressure is substantially more than the internal water pressure, drainage holes may be provided at suitable locations with filters, where necessary, to prevent washing of mountain material into the tunnel. However, when it is not possible to prevent washing of the mountain material into the tunnel drainage holes shall not be provided, if instability is likely to be caused by such washing.

8.1.2 If conveyance of water is through a free pipe located in a tunnel, the horizontal drainage holes shall be drilled near the invert.

9. GROUTING

9.1 Backfill Grouting — Backfill grouting shall be done throughout the length of the concrete lining not earlier than 21 days after the placement of the concrete lining. Stresses likely to develop in concrete at the specified grout pressure may be calculated and seen whether they are within permissible limits depending on the strength attained by concrete by then. Generally the 21 days strength of concrete is sufficient to withstand normal grout pressure which may not exceed about 5 kg/cm².

NOTE -Backfill grouting serves to fill voids and cavities between concrete lining and the surrounding strata. This is generally found necessary near the **crow**n region and may generally extend to not more than 60° angle for circular roof, For flatter arches, the extent may be more.

9.2 Consolidation Grouting or Pressure Grouting — Pressure grouting shall be done at a maximum practicable pressure consistent with the strength of lining and safety against uplift of overburden. The depth of grout holes shall be as directed.

NOTE 1 -Pressure grouting consolidates the surrounding strata and fills any gaps caused by shrinkages of concrete. This grouting is normally specified, **to** improve yield characteristics and thereby the resistance of strata to carry internal water Pressure. As a rule of thumb a grout **pressure** of 1.5 times the internal water pressure in the tunnel may be used subject to the condition that safety against uplift of overburden is ensured. Grout pressures of **upto** 5 to 10 times the water pressure in the **tunnel** have been used in some cases.

NOTE 2 — It is advantageous to provide a grout curtain by means of **extensive** deep grouting at the reservoir end of the tunnel to reduce heavy seepage of **water** and thereby reduce the external water pressure on the lining likely to be developed.

9.3 Grouting shall generally be carried out according to IS: 5878 (Part VII)-1972*.

*Code of practice for construction of tunnels: Part VII Grouting (*under print*).

APPENDIX A

(Clause 5.2)

BASIC CONDITIONS FOR INCLUDING THE EFFECT OF WATER HAMMER IN THE DESIGN

A-1. GENERAL

A-1.1 The basic conditions for including effect of water hammer in the design of tunnels or turbine **penstock** installations are divided into normal and emergency conditions with suitable factors of safety assigned to each type of operation.

A-2. NORMAL CONDITIONS OF OPERATIONS

A-2.1 The basic conditions to be considered **are as** follows:

- a) Turbine **penstock installation** may be operated at any head between the **maximum** and minimum values of **forebay** water surface elevation.
- b) Turbine gates may be moved at any rate of speed by action of the governor head up to a predetermined rate, or at a slower rate by manual control through the auxiliary relay valve.
- c) The turbine may be operating at any gate position and be required to add or drop any or all of **its** load.
- d) If the turbine **penstock** installation is equipped with any of the following pressure controlled devices it will be assumed that **these** devices are properly adjusted and function in all manner for which the equipment is designed:
 - 1) Surge tanks,
 - 2) Relief valves,,
 - 3) Governor control apparatus,
 - 4) Cushioning **stroke** device, and
 - 5) Any other pressure control device.
- e) Unless the actual turbine characteristics are known, the effective area through the turbine gates during the maximum rate of gate movement will be taken as a linear relation with reference to **time**.
- f) The water hammer effects shall be computed on the basis of governor head action for **the** governor **rate** which is actually set on the turbine for speed regulation. If the relay valve stops are

IS: 4880 (Part V) - 1972

adjusted to give a slower governor setting, than that for which the governor is designed this shall be determined prior to proceeding with the design of turbine **penstock** installation and later adhered to at the power plant so that an economical basis for designing the **penstock** scroll case, etc, under normal operating conditions can be established.

- g)** In those instances, where due to higher reservoir elevation, it is necessary to set the stops on the main relay valve for a lower rate of gate movement, water hammer effects will be computed for this slower rate of gate movement also.
- h)** The reduction in head at various points along the **penstock** will be computed for rate of gate opening which is actually set in the governor in those cases where it appears that the profile of the **penstock** is unfavourable. This minimum pressure will then be used as a basis for normal design of the **penstock** to insure that sub-atmospheric pressures will not cause a **penstock** failure due to collapse.
- j)** If a surge is present in the **penstock** system, the upsurge in the surge tank will be computed for the maximum reservoir level condition for the rejection of the turbine flow which corresponds to the rated output of the generator during the gate traversing time which is actually set on the governor.
- k)** The downsurge in the surge tank will be computed for minimum reservoir **level-condition** for a load addition from speed-no-load to the full gate position during the gate traversing time which is actually set on the governor.

A-3. EMERGENCY CONDITIONS

A-3.1 The basic conditions to be considered as an emergency operation are as follows:

- a)** The turbine gates may be closed at any time by the action of the governor head, manual control knob with the main relay valve or the emergency solenoid device.
- b)** The cushioning stroke will be assumed to be inoperative.
- c)** If a relief valve is present, it will be assumed inoperative.
- d)** The gate traversing time will be taken as the minimum time for which the governor is designed.
- e)** The maximum head including water hammer at the turbine and along the length of the **penstock** will be computed for the

maximum reservoir head condition for final part gate closure to the zero gate position at the maximum governor rate in

$$\frac{2L}{a} \text{ seconds}$$

where

L = the length of penstock, and
a = wave velocity.

- f) If a surge tank is present in the **penstock** system, the upsurge in the tank will be computed for the maximum reservoir head condition for the rejections of full gate turbine flow at the maximum rate for which the governor is designed. The downsurge in the surge tank will be computed for the minimum reservoir head condition for full gate opening from the speed-no-load position at the maximum rate for which the governor is designed. In determining the top and bottom elevations of the surge tank nothing will be added to the upsurge and downsurge for this emergency condition of operation.

A-4. EMERGENCY CONDITIONS NOT TO BE CONSIDERED AS A BASIS FOR DESIGN

A-4.1 The other possible emergency conditions of operation are those during which certain pieces of control are assumed to malfunction in the most unfavourable manner. The most severe emergency head rise in a turbine **penstock** installation occurs from either of the two following conditions of operation:

- a) Rapid closure of turbine gates in less than $\frac{2L}{a}$ seconds when the flow of water in the **penstock** is maximum.
- b) Rhythmic opening and closing of the turbine gates when a complete cycle of gate operation is performed in $\frac{4L}{a}$ seconds.

A-4.1.1 Since these conditions of operation require a complete malfunctioning of the governor control apparatus at the most unfavourable moment, the probability of obtaining this type of operation is exceedingly remote. Hence the conditions shall not be used as a basis for design. However, after the design has been established from other considerations it is desirable that the stresses in the turbine scroll case **penstock** and pressure control devices be not in excess of the ultimate bursting strength or twisting strength of structures for these emergency conditions of operation.

APPENDIX B

(Clauses 7.5 and 7.7.1.2)

STRATA LOADS OF TUNNEL LINING

B-1. SCOPE

B-1.1 This appendix gives several alternative methods for evaluating loads from strata on tunnel lining,

B-2. LOAD DISTRIBUTION

B-2.1 The load may be assumed as an equivalent uniformly distributed load over the tunnel soffit over a span equal to the tunnel width or diameter as the case may be.

B-3. LOAD

B-3.1 External loads from the strata may be estimated from the data given in B-3.1.1 to B-3.1.3 for using the appropriate characteristics of the strata.

B-3.1.1 Rock load H_p on the roof of support in tunnel with width B and height H_t , at depth of more than $1.5 (B + H_t)$ may be assumed to be according to Table 2. In case of depths less than $1.5 (B + H_b)$ full may be taken.

TABLE 2 ROCK LOAD ON TUNNELS IN LOOSENING
TYPE OF ROCK

Sl. No.	ROCK CONDITION	ROCK LOAD H_p m	REMARKS
(1)	(2)	(3)	(4)
i)	Hard and intact	Zero	Light lining required only if spalling or popping occurs
ii)	Hard stratified or schistose	0 to $0.50 B$	Light support
iii)	Massive, moderately jointed	0 to $0.25 B$	Load may change erratically from point to point
iv)	Moderately blocky and seamy	$(0.25 \text{ to } 0.35) (B + H_t)$	No side pressure

(Continued)

**TABLE 2 . ROCK LOAD ON TUNNELS IN LOOSENING
TYPE OF ROCK —Contd**

Sl No.	ROCK CONDITION	ROCK LOAD H_p m	REMARKS
(1)	(2)	(3)	(4)
v)	Very blocky and seamy	$(0.35 \text{ to } 1.10) (B + H_t)$	Little or no side pressure
vi)	Completely crushed but chemically intact	$1.10 (B + H_t)$	Considerable side pressure. Softening effect of seepage towards bottom of tunnel. Requires either continuous support for lower ends of ribs or circular ribs
vii)	Squeezing rock	$(1.10 \text{ to } 2.10) (B + H_t)$	Heavy side pressure. Invert struts required
viii)	Squeezing rock, great depth	$(2.10 \text{ to } 4.50) (B + H_t)$	Circular ribs are recommended
ix)	Swelling rock	Up to 80 m irrespective of value of $(B + H_t)$	Circular ribs required, In extreme cases use yielding support

NOTE 1— This table has been arrived on the basis of observations and behaviour of supports in Alpine tunnels where the load was designed mainly for loosening type of rock and gives conservative values.

NOTE 2— The roof of the tunnel is assumed to be located below the water table. If it is located permanently above the water table, the values given for types 4 to 6 may be reduced by fifty percent.

NOTE 3— Some of the most common rock formations contain layers of shale. In an unweathered state, real shales are no worse than other stratified rocks. However, the term shale is often applied to firmly compacted clay sediments which have not yet acquired the properties of rock. Such so called shale may behave in the tunnel like squeezing or even swelling rock.

NOTE 4 -If rock formation consists of sequence of horizontal layers of sand-stone or lime stone and of immature shale, the excavation of the tunnel is commonly associated with a gradual compression of the rock on both sides of the tunnel, involving a downward movement of the roof. Furthermore, the relatively low resistance against slippage at the boundaries between the so called shale and rock is likely to reduce very considerably the capacity of rock located above the roof to bridge. Hence, in such rock formations, the roof pressure may be as heavy as in a very blocky and seamy rock.

B-3.1.2 The rock load according to the Russian practice depends upon the degree of rock firmness. The strength factors after Protodyakonov are given in Table 3. With cover-depth sufficiently deep for arching action,

IS : 4880 (Part V) - 1972

the rock load will be defined by the area enclosed by the arch (see Fig. 1) and assumed to act over the diameter of the tunnel.

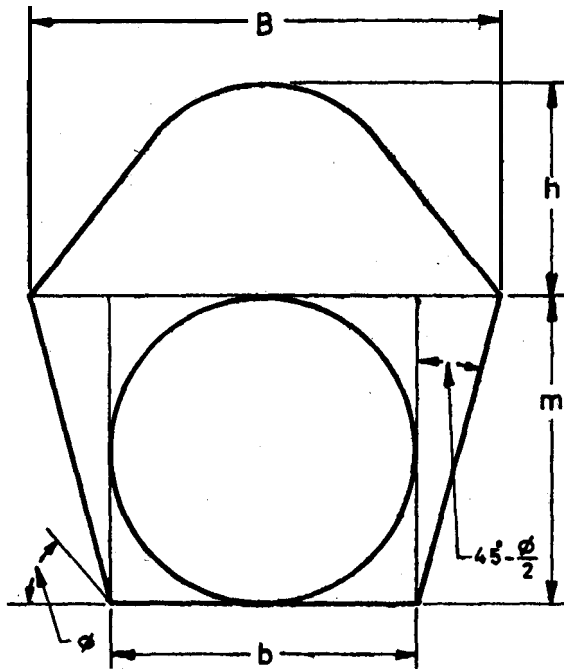

FIG. 1 ASSUMED LOAD ON A CIRCULAR CAVITY

The dimensions of the arch may be obtained from the formulae:

$$h = \frac{B}{2f}$$

$$B = b + 2m \tan (45^\circ - \phi/2)$$

where

f = the strength factor of Protodyakonov (see Table 3),

b = width of tunnel,

m = height of tunnel, and

ϕ = the angle of repose of the soil.

TABLE 3 STRENGTH FACTORS

(Clause B-3.1.2)

CATE- GORY	STRENGTH GRADE	DENOTATION OF ROCK (SOIL)	UNIT WEIGHT (kg/cm ³)	CRUSHING STRENGTH (kg/cm ²)	STRENGTH FACTOR <i>f</i>	
	I	Highest	Solid, dense quartzite , basalt and other solid rocks of exceptionally high strength	2 800-3 000	2000	20
	II	Very high	Solid granite , quartzporphyr, silica shale, highly resistive sandstones and limestones	2 600-2 700	1500	15
	III	High	Granite and alike, very resistive sand and limestones; quartz; solid conglomerates	2 500-2 600	1000	15
	IIIa	High	Limestone , weathered granite, solid sandstone, marble	2 500	800	8
	IV	Moderately strong	Normal sandstone	2400	600	6
	IVa	Moderately strong	Sandstone shales	2300	500	5
	V	Medium	Clay-shales, sand and limestones of smaller resistance, loose conglomerates	2 400-2 600	400	4
	Va	Medium	Various shales and slates, dense marble	2 400-2 800	300	3
	VI	Moderately loose	Loose shale and very loose limestone, gypsum, frozen ground, common marl, blocky sandstone, cemented gravel and boulders, stony ground	2 200-2 600	200-150	2
	Via	Moderately loose	Gravelly ground, blocky and fizzured shale, compressed boulders and gravel, hard clay	2 200-2 400	—	1.5
	VII	Loose	Dense clay, cohesive ballast, clayey ground	2000-2200	—	1.0
	VIIa	Loose	Loose loam, loose gravel	1800-2 000	—	0.8
	VIII	Soils	Soil with vegetation, peat, soft loam, wet sand	1600-1800	—	0.6
	IX	Granular soils	Sand, fine gravel, upfill	1 400-1 600	—	0.5
	X	Plastic soils	Silty ground, modified loose and other soils in liquid condition	—	—	0.3

In the case of circular tunnels, this can be reduced to:

$$B = d [1 + 2 \tan (45^\circ - \phi/2)]$$

$$h = \frac{B}{2f}$$

where

d = diameter of the tunnel.

The load may be taken as uniformly distributed over the diameter of the tunnel.

B-3.1.3 For soils and soft rocks, the unit pressure may be assessed by using Terzaghi's theory:

$$P_v = \frac{B \left[\gamma - \frac{2C}{B} \right]}{2 K \tan \phi} \left[1 - e^{-K \tan \phi \frac{2H}{B}} \right]$$

where

P_v = unit pressure due to load;

$$B = 2 \left[\frac{b}{2} + m \tan (45^\circ - \phi/2) \right];$$

γ = unit weight of overburden (assume saturated weight if tunnel is in saturated soil);

C = co-efficient of cohesion;

b = width of tunnel (diameter for circular tunnel);

m = height of tunnel (diameter for circular tunnel);

ϕ = angle of internal friction;

K = an empirical factor, which increases from 1.0 for $H = B$, to 1.5 for $H = 2.5 B$ and beyond; and

H = height of overburden above tunnel crown.

B-4. LATERAL PRESSURE

B-4.1 Lateral pressures in soils may be determined approximately from earth pressure theory as a product of vertical load and earth pressure co-efficient. Some pressures noted indicate that lateral pressures may range from one-fourth to one-third the roof loads.

a) According to Terzaghi a rough estimate of horizontal pressure p_h is given by:

$$p_h = 0.3 \gamma (0.5 m + h_p)$$

where

Y = density of soil,

m = height of tunnel section, and

h_p = height of loosening core representing the roof load.

h) In granular soils and rock debris:

$$p_h = \gamma H \tan^2 (45^\circ - \phi/2)$$

where

Y = density of soil,

H = height of overburden above tunnel crown, and

ϕ = angle of internal friction.

c) In cohesive soils the pressure at the crown e^1 and pressure at the invert e^2 may be calculated according to the method* given below:

$$e^1 = h \tan^2 (45^\circ - \phi/2) - 2C \tan (45^\circ - \phi/2)$$

$$e^2 = (h + m Y) \tan^2 (45^\circ - \phi/2) - 2C \tan (45^\circ - \phi/2)$$

where

h = height corresponding to vertical load,

ϕ = angle of internal friction,

c = cohesion co-efficient,

m = height of tunnel section, and

Y = density of soil.

d) The lateral active pressure may be increased to take into account the passive resistance developed due to deformation of the lining.

APPENDIX C

(Clause 7.9.1)

BASIC EQUATIONS FOR ANALYSIS OF TUNNEL LINING CONSIDERING IT AND THE SURROUNDING ROCK AS A COMPOSITE CYLINDER

C-1. SCOPE

C-1.1 This appendix contains basic equations for calculating radial and tangential stresses in concrete lining and the surrounding rock mass considering both as parts of a composite cylinder.

*Soviet practice.

C-2. NOTATIONS

C-2.1 For this appendix the following notations shall apply:

p = internal hydrostatic pressure (negative : compression);

$\sigma_{t_1}, \sigma_{t_2}, \sigma_{t_3}$ = tangential stress in rock, concrete and steel respectively;

$\sigma_{r_1}, \sigma_{r_2}, \sigma_{r_3}$ = radial stress in rock, concrete and steel respectively;

E_1, E_2, E_3 = modulus of elasticity of rock, concrete and steel respectively;

m_1, m_2 = Poisson's ratio of rock and concrete respectively;

U_1, U_2, U_3 = radial deformation in rock concrete and steel respectively;

x = radius of element;

B, C, etc = integration constants;

A = area of reinforcement per unit length of tunnel;

a = internal diameter of the tunnel; and

b = external diameter of the lining up to A-line.

C-3. BASIC EQUATIONS

C-3.1 Plain cement concrete lining considering that it is not cracked.

$$\sigma_r = \frac{m E}{m^2 - 1} \left[B (m + 1) - \frac{C}{x^2} (m - 1) \right]$$

$$\sigma_t = \frac{m E}{m^2 - 1} \left[B (m + 1) + \frac{C}{x^2} (m - 1) \right]$$

$$U = Bx + C/x$$

C-3.13 Limit Conditions

- a) When $x = \infty$, $\sigma_{r_1} = 0$
- b) When $x = b$, $\sigma_{r_1} = \sigma_{r_2}$
- c) When $x = b$, $\sigma_{r_2} = -p$
- d) When $x = b$, $U_1 = U_2$

C-3.2 Plain cement concrete lining considering that it is cracked

a) For rock:

$$\sigma_{r_1} = \frac{m_1 E_1}{m_1^2 - 1} \left[B_1 (m_1 + 1) - \frac{C_1}{x^2} (m_1 - 1) \right]$$

$$\sigma_{t_1} = \frac{m_1 E_1}{m_1^2 - 1} \left[B_1 (m_1 + 1) - \frac{C_1}{x^2} (m_1 - 1) \right]$$

b) For concrete:

$$\sigma_{r_2} = \frac{a (\sigma_{r_2})_{x=a}}{x}$$

$$\sigma_{t_2} = 0 \text{ (since concrete does not take any tangential stress)}$$

C-3.2.1 *Limit Conditions*

a) When $x = \infty$, $\sigma_{r_1} = 0$

b) When $x = b$, $\sigma_{r_1} = \sigma_{r_2}$

c) When $x = a$, $\sigma_{r_2} = -p$

C-3.2.1.1 Constants are given by:

$$B_1 = 0$$

$$C_1 = \frac{a \cdot b \cdot p \cdot (m_1 + 1)}{m_1 E_1}$$

$$(\sigma_{r_2})_{x=a} = -P$$

C-3.3 Plain cement concrete lining considering that it is cracked and surrounding rock also is cracked for a **distance** equal to a radius **y beyond which** rock is massive and **uncracked**

a) For concrete:

$$\sigma_{r_2} = \frac{a (\sigma_{r_2})_{x=a}}{x}$$

$$\sigma_{t_2} = 0$$

b) For cracked rock:

$$\sigma_{r_1}' = \frac{a (\sigma_{r_2})_{x=a}}{x}$$

$$\sigma_{t_1}' = 0$$

NOTE — Symbols σ_{r_1}' and σ_{t_1}' refer to cracked zone of rock.

c) For surrounding uncracked rock:

$$\sigma_{r_1} = \frac{m_1 E_1}{m_1^2 - 1} \left[B_1 (m_1 + 1) - \frac{C_1}{x^2} (m_1 - 1) \right]$$

$$\sigma_{t_1} = \frac{m_1 E_1}{m_1^2 - 1} \left[B_1 (m_1 + 1) + \frac{C_1}{x^2} (m_1 - 1) \right]$$

C-3.3.1 Limit Conditions

- At $x = \infty$, $\sigma_{r_1} = 0$
- At $x = y$, $\sigma_{r_1} = \sigma_{r_1}'$
- At $x = b$, $\sigma_{r_2} = \sigma_{r_1}'$
- At $x = a$, $\sigma_{r_2} = -p$

C-3.4 Reinforced cement concrete lining considering that it is not cracked

$$\sigma_r = \frac{m E}{m^2 - 1} \left[B (m + 1) - \frac{C_1}{x^2} (m - 1) \right]$$

$$\sigma_t = \frac{m E}{m^2 - 1} \left[B (m + 1) + \frac{C_1}{x^2} (m - 1) \right]$$

$$U = Bx + C/x$$

$$\sigma_{t_3} = \frac{E_3}{a} \left(B_2 a + \frac{C_2}{a} \right)$$

$$\sigma_{r_3} = \frac{E_3 A_2}{a^2} \left(B_2 a + \frac{C_2}{a} \right)$$

C-3.4.1 Limit Conditions

- At $x = \infty$, $\sigma_{r_1} = 0$
- At $x = b$, $\sigma_{r_1} = \sigma_{r_2}$
- At $x = a$, $\sigma_{r_2} - \sigma_{r_1} = -p$
- At $x = b$, $U_1 = U_2$

C-3.4.1 .1 Constants are given by:

$$C_1 = B_2 b^2 + C_2$$

$$C_1 = \left(\frac{E_2 m_2 (m_1 + 1)}{E_1 m_1 (m_2 + 1)} \right) C_2 - \left(\frac{E_2 m_2 (m_1 + 1)}{E_1 m_1 (m_2 - 1)} \right) B_2 b^2$$

$$-p = B_2 \left(\frac{E_2 m_2}{m_2 - 1} - \frac{E_3 A_s}{a} \right) - \left(\frac{E_2 m_2}{a^2 (m_2 + 1)} + \frac{E_3 A_s}{a^3} \right) C_2$$

C-3.5 Reinforced cement concrete lining considering that it is cracked and that because of radial cracks it cannot take tangential tensile stress

a) For rock:

$$\sigma_{t_1} = \frac{E_1 m_1 C_1}{(m_1 + 1)^2 x^2}$$

$$\sigma_{r_1} = -\sigma_{t_1}$$

$$U_1 = \frac{C_1}{x}$$

b) For concrete:

$$\sigma_{t_2} = 0$$

$$\sigma_{r_2} = \frac{a (\sigma_{r_2})_{x=a}}{x}$$

$$U_2 = \frac{a (\sigma_{r_2})_{x=a}}{E_2} \log b/a$$

c) For steel:

$$\sigma_{t_3} = \frac{a \sigma_{r_3}}{A_s}$$

$$\sigma_{r_3} = \frac{E_3 A_s}{a^2} (aB_2 + C_2/a)$$

$$U_3 = \frac{a^2 \sigma_{r_3}}{E_3 A_s}$$

C-3.5.1 Constants are given by:

$$(\sigma_{r_2})_{x=a} = \frac{-pam_1 E_1 E_2}{am_1 E_1 E_2 + m_1 E_1 E_3 A_s \log(b/a) + (m_1 + 1) E_2 E_3 A_s}$$

$$C_1 = \frac{-ab(m_1 + 1)(\sigma_{r_2})_{x=a}}{m_1 E_1}$$

$$\sigma_{r_3} = (\sigma_{r_2})_{x=a} + p$$

BUREAU OF INDIAN STANDARDS

Headquarters :

Manak Bhavan, 9 Bahadur Shah **Zafar Marg**, NEW DELHI 110002

Telephones: 331 01 31

Telegrams : Manaksanstha

331 1375

(Common to all Offices)

Regional Offices :

		<i>Telephone</i>
Central	: Manak Bhavan, 9. Bahadur Shah Zafar Marg , NEW DELHI 110002	{ 331 01 31 331 13 75
* Eastern	: 1114 C.I.T. Scheme VIIM , V.I.P. Road, Maniktola, CALCUTTA 700054	37 86 62
Northern	: SCO 445-446, Sector 35-C, CHANDIGARH 160036	2 18 4 3
Southern	: C.I.T. Campus, IV Cross Road, MADRAS 600113	41 29 16
† Western	: Manakalaya, E9 MIDC, Marol, Andheri (East), BOMBAY 400093	6 32 92 95

Branch Offices :

'Pushpak', Nurmohamed Shaikh Marg, Khanpur, AHMADABAD 380001	2 63 48
‡ Peenya Industrial Area, 1 st Stage, Bangalore-Tumkur Road, BANGALORE 560058	39 49 55
Gangotri Complex, 5th Floor, Bhadbhada Road, T.T. Nagar, B HOPAL 462003	55 40 21
Plot No. 82/83 , Lewis Road, BHUBANESHWAR 751002	5 36 27
Kalai Kathir Building, 6/48-A Avanasi Road, COIMBATORE 641037	2 67 05
Quality Marking Centre, N.H. IV, N.I.T. , FARIDABAD 121001	—
Savitri Complex, 116 G. T. Road, GHAZIABAD 201001	B-71 19 96
53/5 Ward No. 29, R.G. Barua Road, 5th By-lane, GUWAHATI 781003	3 31 77
5-8-56C L. N. Gupta Marg, (Nampally Station Road) HYDERABAD 500001	2 31 0 8 3
R14 Yudhister Marg, C Scheme, JAIPUR 302005	6 34 71
117/418 B Sarvodaya Nagar, KANPUR 208005	21 68 76
Plot No. A-9, House No. 561/63 , Sindhu Nagar, Kanpur Road. LUCKNOW 226005	5 55 07
Patliputra Industrial Estate, PATNA 800013	6 23 05
District Industries Centre Complex, Bagh-e-Ali Maidan , SRI NAGAR 190011	—
T. C. No. 14/1421 , University P. O., Palayam, THIRUVANANTHAPURAM 695034	6 21 04
Inspection offices (With Sale Point) :	
Pushpanjali. First Floor, 205-A West High Court Road. Shankar Nagar Square, NAGPUR 440010	52 51 71
Institution of Engineers (India) Building, 1332 Shivaji Nagar. PUNE 411005	5 24 3 5
*Sales Office Calcutta is at 5 Chowringhee Approach, P. O. Princep Street, CALCUTTA	27 68 00
† Sales Office is at Novelty Chambers, Grant Road, BOMBAY	89 65 28
‡ Sales Office is at Unity Building, Narasimharaja Square, BANGALORE	22 39 71

AMENDMENT NO. 1 MARCH 1986

TO

IS:4880(Part 5)-1972 CODE OF PRACTICE FOR DESIGN OF
TUNNELS CONVEYING WATER

PART 5 STRUCTURAL DESIGN OF CONCRETE
LINING IN SOFT STRATA AND SOILS

(Page 24, clause C-2.1, line 7) - Substitute the following for the existing line:

" m_1, m_2 = Poisson's number of rock and concrete respectively;"

(Page 24, clause C-2.1, lines 13 and 74) - Substitute the following for the existing lines:

' a = internal radius of the tunnel; and

b = external radius of the lining up to A-line.'

(BDC 58)