

Indian Standard

METHODS OF TEST FOR STABILIZED SOILS

PART IX DETERMINATION OF THE BITUMINOUS STABILIZER CONTENT OF BITUMEN AND TAR STABILIZED SOILS

(First Reprint DECEMBER 1983)

UDC 624.138.232.2



© Copyright 1971

INDIAN STANDARDS INSTITUTION
MANAK BHAVAN, 9 BAHADUR SHAH ZAFAR MARG
NEW DELHI 110002

*Indian Standard***METHODS OF TEST FOR STABILIZED SOILS****PART IX DETERMINATION OF THE BITUMINOUS
STABILIZER CONTENT OF BITUMEN AND
TAR STABILIZED SOILS**

Soil Engineering Sectional Committee, BDC 23

Chairman

PROF S. R. MEHRA

Manak, Old Adhikari Lodge,
Ranikhet, Uttar Pradesh*Members**Representing*

DR ALAM SINGH

SHRI B. B. L. BHATNAGAR

SHRI K. N. DADINA

SHRI A. G. DASTIDAR

SHRI J. DATT

SHRI T. M. MENON (*Alternate*)

SHRI R. L. DEWAN

PROF DINESH MOHAN

SHRI D. R. NARAHARI (*Alternate*)DIRECTOR, CENTRAL SOIL MECHANICS
RESEARCH STATIONDIRECTOR (DAMS II) (*Alternate*)

PROF R. N. DOGRA

SHRI B. N. GUPTA

DR JAGDISH NARAIN

SHRI P. C. JAIN

SHRI B. S. BHATTI (*Alternate*)JOINT DIRECTOR RESEARCH (FE),
RDSODEPUTY DIRECTOR RESEARCH
SOIL, MECHANICS,
RDSO (*Alternate*)

SHRI S. S. JOSHI

SHRI S. VARADARAJA (*Alternate*)

SHRI G. KUECKELMANN

SHRI A. H. DIVANJI (*Alternate*)

SHRI O. P. MALHOTRA

SHRI C. B. PATEL

University of Jodhpur, Jodhpur

Land Reclamation, Irrigation & Power Research
Institute, AmritsarIn personal capacity (*P-820, New Alipore, Calcutta 53*)

Cementation Co Ltd, Bombay

Concrete Association of India, Bombay

Bihar Institute of Hydraulic and Allied Research,
Khagaul, Patna

Central Building Research Institute (CSIR), Roorkee

Central Water & Power Commission, New Delhi

Indian Institute of Technology, New Delhi

Irrigation Research Institute, Roorkee

University of Roorkee, Roorkee

National Buildings Organization, New Delhi

Railway Board (Ministry of Railways)

Engineer-in-Chief's Branch, Army Headquarters

Rodio Foundation Engineering Ltd; and Hazarat &
Co, Bombay

Public Works Department, Government of Punjab

M. N. Dastur & Co (Private) Ltd, Calcutta

(Continued on page 2)

(Continued from page 1)

<i>Members</i>	<i>Representing</i>
REPRESENTATIVE	All India Instruments Manufacturers & Dealers Association, Bombay
REPRESENTATIVE	Indian National Society of Soil Mechanics & Foundation Engineering, New Delhi
REPRESENTATIVE	Public Works Directorate (Special Roads), Government of West Bengal
RESEARCH OFFICER	Building and Roads Research Laboratory, Public Works Department, Government of Punjab
RESEARCH OFFICER	Engineering Research Department, Hyderabad
SECRETARY	Central Board of Irrigation and Power, New Delhi
SHRI S. N. SINHA	Roads Wing (Ministry of Transport & Shipping)
SHRI A. S. BISHNOI (<i>Alternate</i>)	Concrete and Soil Research Laboratory, Public Works Department, Government of Tamil Nadu
SUPERINTENDING ENGINEER (PLANNING & DESIGN CIRCLE)	
EXECUTIVE ENGINEER (SOIL MECHANICS & RESEARCH DIVISION) (<i>Alternate</i>)	
SHRI C. G. SWAMINATHAN	Institution of Engineers (India), Calcutta
DR H. L. UPPAL	Central Road Research Institute (CSIR), New Delhi
SHRI H. G. VERMA	Public Works Department, Government of Uttar Pradesh
SHRI D. C. CHATURVEDI (<i>Alternate</i>)	Director General, ISI (<i>Ex-officio Member</i>)
SHRI R. NAGARAJAN, Director (Civ Engg)	
	<i>Secretary</i>
	SHRI G. RAMAN
	Deputy Director (Civ Engg), ISI

Soil Testing Procedures and Equipment Subcommittee, BDC 23:3

<i>Convener</i>	
DR H. L. UPPAL	Central Road Research Institute (CSIR), New Delhi
<i>Members</i>	
DR ALAM SINGH	University of Jodhpur, Jodhpur
SHRI T. N. BHARGAVA	Roads Wing (Ministry of Transport & Shipping)
SHRI A. S. BISHNOI (<i>Alternate</i>)	
SHRI R. L. DEWAN	Bihar Institute of Hydraulic and Allied Research, Khagaul, Patna
DIRECTOR (CENTRAL SOIL MECHANICS & RESEARCH STATION)	Central Water & Power Commission, New Delhi
DIRECTOR (DAMS II) (<i>Alternate</i>)	
SHRI H. K. GUHA	Geologists Syndicate Private Ltd, Calcutta
SHRI N. N. BHATTACHARYYA (<i>Alternate</i>)	Engineer-in-Chief's Branch, Army Headquarters
SHRI S. S. JOSHI	Public Works Department, Government of Uttar Pradesh
SHRI MAHABIR PRASAD	Buildings and Road Research Laboratory, Chandigarh
SHRI O. P. MALHOTRA	
DR I. S. UPPAL (<i>Alternate</i>)	Central Building Research Institute (CSIR), Roorkee
SHRI D. R. NARAHARI	
SHRI G. S. JAIN (<i>Alternate</i>)	Associated Instrument Manufacturers (India) Private Limited, New Delhi
SHRI H. C. VERMA	
SHRI M. N. BALIGA (<i>Alternate</i>)	

Indian Standard

METHODS OF TEST FOR STABILIZED SOILS

PART IX DETERMINATION OF THE BITUMINOUS STABILIZER CONTENT OF BITUMEN AND TAR STABILIZED SOILS

0. FOREWORD

0.1 This Indian Standard (Part IX) was adopted by the Indian Standards Institution on 25 September 1970, after the draft finalized by the Soil Engineering Sectional Committee had been approved by the Civil Engineering Division Council.

0.2 Soil stabilization is the alteration of any property of a soil to improve its engineering performance. There are several methods of stabilization and these may be broadly on the basis of treatment given to the soil (for example, dewatering and compaction), process involved (for example, thermal and electrical) and on additives employed (for example, asphalt and cement). The choice of a particular method depends on the characteristics of the problem on hand. For studying in the laboratory, the methods and effects of stabilization, certain standard methods of test for the evaluation of properties of stabilized soils and their analysis are required. The required standards on methods of test for stabilized soils are being published in parts. This part (Part IX) lays down the method for the determination of the bituminous stabilizer content of bitumen and tar stabilized soils.

0.3 In the formulation of this standard due weightage has been given to international co-ordination among the standards and practices prevailing in different countries in addition to relating it to the practices in this field in this country.

0.4 In reporting the result of a test or analysis made in accordance with this standard, if the final value, observed or calculated is to be rounded off, it shall be done in accordance with IS : 2-1960*.

SECTION A TEST WHERE AMBIENT TEMPERATURE DOES NOT EXCEED 30°C

1. SCOPE

1.1 This Section of the standard (Part IX) covers the determination of the proportion by weight of bituminous stabilizer present in a stabilized

*Rules for rounding off numerical values (*revised*).

IS: 4332 (Part IX)-1970

soil mixture. It is not suitable for use in climatic conditions where the ambient temperature exceeds 30°C because of the high rate of evaporation of the solvent used in the test.

2. GROUPING OF SOIL

2.1 For the purpose of this standard, soils shall be grouped as given below :

Fine-Grained Soils — Soils containing particles over about 90 percent of which pass a 2·36-mm IS Sieve (*see* IS : 460-1962*)

Medium-Grained Soils — Soils containing particles over about 90 percent of which pass a 20-mm IS Sieve (*see* IS : 460-1962*)

Coarse-Grained Soils — Soils containing particles over about 90 percent of which pass a 40-mm IS Sieve (*see* IS : 460-1962*)

3. APPARATUS

3.1 Balance — readable and accurate to 0·001 g.

3.2 Balance — capable of weighing to 250 g, 5 kg and 10 kg, readable accurate to 0·01 g, 0·5 g and 1 g respectively.

3.3 Wide Mounted Metal Bottle — of approximately 600 ml¹, 2 500 ml or 7 000 ml capacity (as appropriate) with a tight fitting rubber stopper.

3.4 Steel Balls — three, of 20 to 25 mm diameter.

3.5 Mechanical Bottle Shaker — preferably giving an end-over-end shaking action at 60 rev/min.

3.6 A 200-ml Carbon Dioxide Flask

3.7 Graduated Measuring Cylinders — 1 000 ml, 500 ml and 250 ml.

3.8 Porous Alumina or Porous Porcelain or Sintered Ware Filter Candle — approximately 80 mm long × 30 mm diameter having a pore size 2·4 μ (*see* Fig. 1).

3.8.1 The filters are converted into enclosed filters by sealing in, to within 12 mm of the bottom end, a length of metal or glass tubing through a cork or metal ring placed in the open top end to act as a support. The tube is sealed in with a cementing paste composed of copper oxide power (prepared by direct oxidation of copper wire) passing the 425-micron

*Specification for test sieves (*revised*).

IS sieve and retained on 300-micron IS sieve (*see* IS : 460-1962*) mixed with phosphoric acid, applied immediately and left for a few hours to dry in air. Other sealing compound, such as plaster of paris mixed with asbestos fibre may be used. Alternatively, the filtration assembly may be replaced with a centrifuge capable of speed up to at least 4000 rev/min when carrying two or more buckets fitted with centrifuge tubes of 50 ml capacity and having a diameter not less than 28 cm from tip of the rotating tubes. The tubes shall be closed with caps.

3.9 Burette — of 50 ml with a two-way tap, connected to the filtering assembly in the manner shown in Fig. 2.

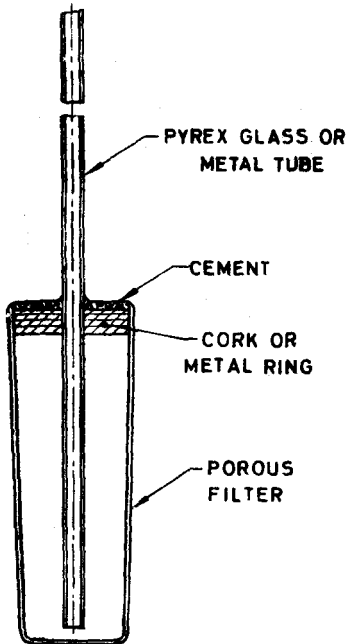

FIG. 1 ASSEMBLY OF FILTER FOR THE DETERMINATION OF THE BITUMINOUS STABILIZER CONTENT OF STABILIZED SOILS

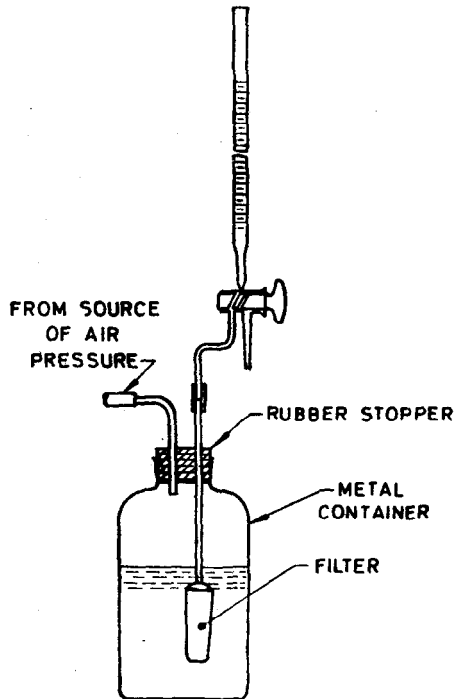

FIG. 2 FILTERING ASSEMBLY FOR THE DETERMINATION OF THE BITUMINOUS STABILIZER CONTENT OF STABILIZED SOILS

*Specification for test sieves (*revised*).

3.10 Recovery Apparatus — consisting of a water bath approximately 15 cm diameter, a manometer, a vacuum reservoir and a source of vacuum (see Fig. 3).

3.11 Desiccator — containing anhydrous silica gel.

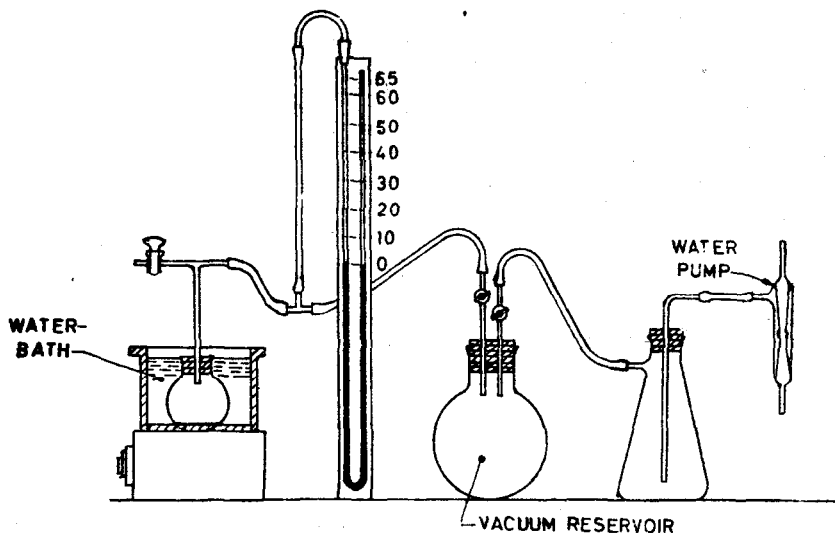

FIG. 3 APPARATUS FOR THE DETERMINATION OF BITUMINOUS STABILIZER CONTENT

4. REAGENTS

4.1 The reagents shall be of recognized analytical reagent quality.

- a) *Dichloromethane (methylene chloride)* — 95 percent collected between 39 and 40.5°C.
- b) *Silica gel* — powdered, to pass a 75-micron IS Sieve.

5. PREPARATION OF SAMPLE

5.1 The bulk sample shall be reduced by hand into small pieces, and this may be facilitated if necessary by slight warming. The sample shall then be quartered successively until representative samples of the following weights are obtained:

Fine-grained soils	150-200 g
Medium-grained soils	1 000-1 500 g
Coarse-grained soils	5 000-6 000 g

6. PROCEDURE

6.1 The representative samples of the soil-bituminous stabilizer mixture, obtained as in 5 containing a known weight of water (a g) [which shall be determined in accordance with IS: 4332 (Part II)-1967*] shall be weighed to the nearest 0.01 percent of the weight taken (W) and introduced into a wide-mouthed metal bottle of appropriate capacity. Powdered silica gel shall be added to absorb water, the quantity being equal to half the weight of water present. In the case of fine-grained soils, three steel balls shall then be placed in the bottle to assist in breaking down the mix. A volume of dichloromethane measured to the nearest 0.5 percent of the volume taken (V ml) shall be added to the soil in sufficient quantity to obtain a solution containing 2 to 3 percent of stabilizer. After insertion of the rubber stopper, the bottle shall be shaken for 30 minutes on the mechanical shaker in the case of fine-grained soils and for 60 minutes in the case of medium- and coarse-grained soils.

6.2 A portion of the soil stabilizer solution so obtained shall be filtered through the alumina or porous filter into the burette by the arrangement shown in Fig. 2, or shall be centrifuged. If the solution is to be centrifuged, the centrifuge tubes shall be tightly stoppered to avoid losses due to evaporation. Sufficient quantity of the solution (v ml) shall then be transferred by means of a burette into 200 ml carbon dioxide flask, the weight of which shall be known to the nearest 0.001 g, to give an estimated weight of approximately 0.75-1.25 g of recovered stabilizer. If the first amount obtained lies outside these limits another suitably adjusted portion of the solution shall be taken. The flask shall then be connected to the vacuum line, the manometer and the reservoir, and placed in a water-bath maintained at 100°C (see Fig. 3). The bulk of the solvent shall be evaporated with the pressure reduced to 500 ± 50 mm Hg, the flask being shaken with a rotary motion during the course of the evaporation. For complete removal of solvent one of the following procedures shall be adopted:

- a) *For Bitumen Emulsions, Tar Emulsions, or Tars Above 42°C Equiviscous Temperature* — In the last stages of evaporation, when frothing occurs, pressure shall be reduced to 150 mm Hg in $1\frac{1}{2}$ minutes and maintained at this value for a further $3\frac{1}{2}$ minutes.
- b) *For Petroleum Oils, Cut-Back Bitumens or Tars of 42°C Equiviscous Temperature, or Below* — In the last stages of evaporation, when frothing occurs, the pressure in the apparatus shall be increased to approximately atmospheric and subsequently lowered to

*Methods of test for stabilized soils: Part II Determination of moisture content of stabilized soil mixtures.

450 mm Hg in $1\frac{1}{2}$ minutes. This pressure shall be maintained for a further $3\frac{1}{2}$ minutes. The reduced pressure may conveniently be obtained by a water filter-pump; if this is not available a suitable mechanical vacuum pump may be used, in which case the following procedures shall be adopted :

The bulk of the methylene chloride shall be distilled off before connecting the flask to the vacuum line. To ensure that solvent vapour does not reach the pump, the flask shall be connected to the pump through a reservoir consisting of a flask containing lubricating oil of medium viscosity, followed by a tower containing activated carbon (1.4 mm to 780 microns). The procedure subsequently followed shall be as given in 6.2 (a) and (b).

6.3 The flask shall be removed from the water bath and air admitted gently to the apparatus. After wiping the flask, the last trace of dichloromethane shall be removed by means of a gentle air current. The flask shall then be cooled for 5 minutes in a desiccator and weighed to the nearest 0.001 g and the weight of recovered stabilizer (W_1) determined by difference.

6.4 Soluble Portion of Untreated Soil—A test shall be carried out under the same conditions on the untreated soil to determine the quantity (W'_2 g) which may be soluble in dichloromethane, and this shall be deducted from the total soluble content of the stabilized soil. Unless the soil has been previously stabilized with bitumen, however, the soluble portion is usually negligible and may be ignored.

6.5 Insoluble Portion of Stabilizer—Bitumens are generally completely soluble in dichloromethane, but some petroleum stabilizing oils may contain wax which is insoluble; similarly, certain naturally-occurring bitumens may contain insoluble mineral matter. Refined tars also contain a proportion of material insoluble in dichloromethane.

In such cases allowance shall be made for the insoluble portion in the calculation of the total stabilizer content. The insoluble matter shall be determined by dissolving a representative portion of the stabilizer in dichloromethane and filtering through a Gooch or sintered silica crucible or a filter paper. The percentage of soluble stabilizer (P) shall then be calculated.

NOTE—For general principles of determination of insoluble matter, see IS : 1215-1958*.

*Method for testing tar and bitumen : Determination of matter insoluble in toluene.

7. CALCULATIONS

7.1 The stabilizer content (S_1) of the mixture shall be calculated from the formula:

$$S_1 = \frac{100(W_1 - W_2)V}{Wv} \left[1 + \frac{W_1 - W_2}{\rho v} \right] \frac{100}{P} \text{ percent}$$

where

W_1 = weight of soluble material recovered from aliquot in g ;

W_2 = weight of soil soluble in dichloromethane in g ;

V = total volume of dichloromethane in ml ;

W = weight of sample taken in g ;

v = volume of aliquot of dichloromethane digest in ml ;

ρ = density of recovered stabilizer (g/cm^3) (when a sample of original stabilizer is not available, an average value of 1.00 for bitumen and 1.175 for tars may be assumed) ; and

P = percentage of stabilizer soluble in dichloromethane.

7.2 The stabilizer content (S_2) expressed as a percentage of the weight of dry soil shall be estimated from the formula:

$$S_2 = \frac{100 WS_1}{100(W-a) - WS_1} \text{ percent}$$

where

a = weight of water present in W g of sample determined as in IS: 4332 (Part II)-1967*.

8. REPORTING OF RESULTS

8.1 The results of the test should be suitably recorded.

8.2 The results shall be expressed as the proportion of stabilizer present to the nearest 0.1 percent.

SECTION B TEST WHERE AMBIENT TEMPERATURE EXCEEDS 30°C

9. SCOPE

9.1 This Section of the standard (Part IX) covers the determination of the proportion by weight of bituminous stabilizer present in a stabilized soil mixture and is suitable for climatic conditions where temperature exceeds 30°C.

*Methods of test for stabilized soils: Part II Determination of moisture content of stabilized soil mixtures.

10. APPARATUS

10.1 The apparatus shall consist of a hot extractor as shown in Fig. 6 consisting of components as given below:

- a) A cylindrical container (Fig. 4) made from brass gauze of about 3 mm which is rested on, or suspended from three pegs inside a brass or welded iron pot (Fig. 5). Alternatively, the brass gauze container may rest on a suitable 'stool' standing in the bottom of the pot. The pot is flanged and fitted with a cover and suitable jointing gasket. The cover is held in position by swivelling bolts fitted with wing nuts. The essential features of construction are indicated in Fig. 4, 5 and 6. It is advantageous to have containers and pots of more than one size, the size employed being appropriate to the quantity of material taken for analysis.
- b) A graduated receiver conforming to Fig. 7 and an adequate reflux container. There should be a sufficient flow of cold water to condense the solvent.
- c) A suitable heater, such as an electric plate or a gas ring.
- d) Suitable filter paper.

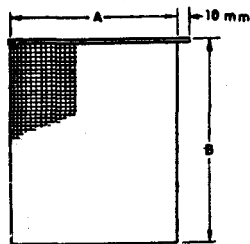

A — From 125 mm to 200 mm ϕ as appropriate
 B — From 125 mm to 250 mm ϕ

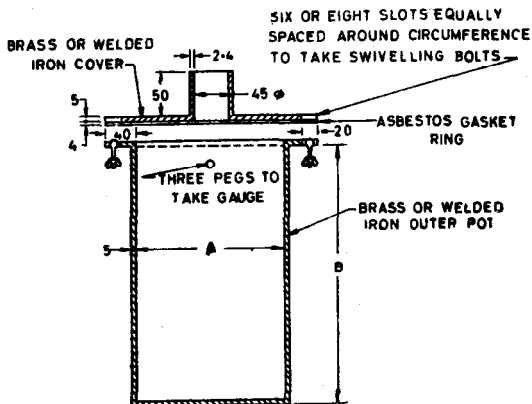

A — From 125 mm to 225 mm ϕ as appropriate
 B — From 200 mm to 375 mm ϕ as appropriate
 All dimensions in millimetres.

FIG. 4 CYLINDRICAL CONTAINER

FIG. 5 BRASS OR WELDED IRON POT

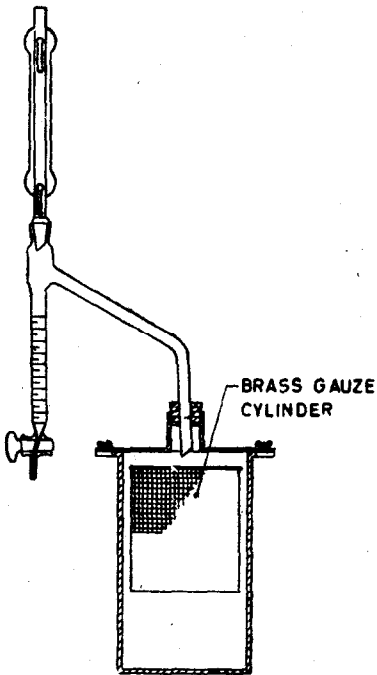
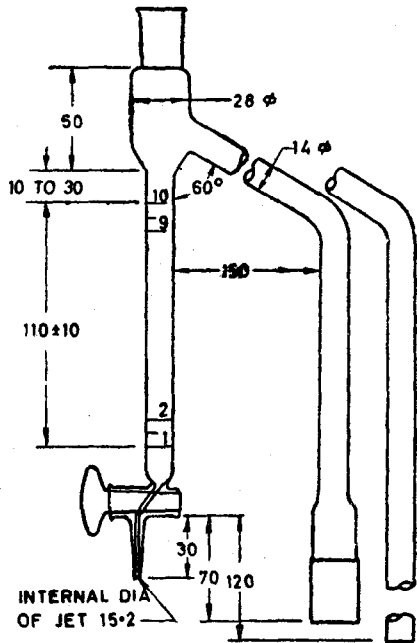

FIG. 6 ASSEMBLED APPARATUS



All dimensions in millimetres.

FIG. 7 10 ml RECEIVER SHOWING ALTERNATIVE CONNECTIONS TO DISTILLATION VESSEL

11. SOLVENT

11.1 The solvent shall be pure toluole in accordance with IS : 536-1968*.

12. SIZE OF SAMPLE

12.1 The quantities of material taken shall be in accordance with Table 1.

13. PROCEDURE

13.1 The filter paper shall be dried at 100-120°C, placed in a large weighing bottle or jar, cooled in a desiccator and weighed. The filter paper shall then be fitted into gauze cylinder to form a complete lining.

*Specification for toluole, industrial (first revision).

TABLE 1 SIZE OF SAMPLE

(Clause 12.1)

SL No.	GRADING OF SOIL	MINIMUM WEIGHT FOR EACH DETERMINATION
(1)	(2)	(3)
i)	More than 25 percent retained on a 40-mm IS sieve	5 000
ii)	Largely retained on 20-mm but not more than 25 percent retained on a 40-mm IS sieve	3 000
iii)	Largely retained on 12-mm but not more than 25 percent retained on a 25-mm IS sieve	2 000
iv)	Largely retained on 6.3-mm but not more than 25 percent retained on a 20-mm IS sieve	1 000
v)	Largely retained on 3.35-mm but not more than 25 percent retained on a 6.3-mm IS sieve	500
vi)	Not more than 25 percent retained on a 2.36-mm IS sieve and not more than 20 percent passing a 75-micron IS sieve	200

The sample shall be warmed just sufficiently to facilitate breaking up, and a representative portion (*see* Note) obtained if possible by quartering, and having the weight as indicated in Table 1, shall be weighed to the nearest 0.05 percent of the weight taken and transferred without loss to the filter paper and placed inside the gauze cylinder. Alternatively, the cylinder and its lining may be placed on the balance and the material weighed into it. The gauze cylinder shall then be placed inside the pot and 800-1500 ml of the solvent according to the size of the extractor, shall be poured over the sample. The cover shall be bolted on with the dried gasket in position. Water shall be added to the receiver up to or a little beyond the lowest graduation and this quantity subsequently deducted from the total volume of water collected. After fixing the reflux condenser, heat shall be applied to the pot and so adjusted as to avoid intense local heating, but at the same time to ensure a steady reflex action of 2 to 5 drops per second falling from the end of the condenser.

NOTE—When quantity for the test exceeds the capacity of the apparatus, the extraction should be carried out in two operations.

13.2 Any water present in the sample will collect in the receiving tube, while the solvent will fill the tube, flow back over the sample and drain through the filter paper to the bottom of the pot.

13.3 If water is removed from the receiver during the extraction, in order to obviate fire risk the gas flame should be extinguished before doing this.

13.3.1 Heating shall be continued until extraction is complete and water ceases to collect in the receiver.

13.4 The washed mineral aggregate, with its container, shall then be removed and dried to constant weight (*see* Note) at a temperature of 100-120°C. The cylinder and contents shall be cooled in a desiccator before weighing. In order to correct for any fine material present in the solution at the end of the test, the solvent shall be evaporated off, the residue weighed, and a representative portion of it (between 2 g and 3 g) treated with the solvent and filtered through a sintered silica or glass filtering crucible or filter paper as in the determination of insoluble matter (*see* IS: 1215-1958*). In the case of materials containing natural asphalt or high filler content the whole of the solution at the end of the test should be filtered or centrifuged.

NOTE—Material shall be deemed to be at constant weight when the difference between successive weighings at half-hourly intervals does not exceed 0.05 percent.

14. CALCULATIONS

14.1 The soluble binder content S shall be calculated on the dry sample by means of the following formula:

$$S = 100 \frac{W_1 - (W_2 + M + kW_3/100)}{W_1 - M} \text{ percent by weight}$$

where

W_1 = weight of undried sample in g,

W_2 = weight of recovered aggregate in gauze cylinder in g,

M = weight of water collected in test in g,

k = percent by weight of insoluble matter in residue obtained on evaporating the solvent, and

W_3 = weight in g of residue obtained on evaporating the solvent.

14.2 The total binder content B shall be calculated on the dry sample by means of the following formula:

$$B = \frac{100 S}{T} \text{ percent by weight}$$

*Methods for testing tar and bitumen: Determination of matter insoluble in toluene.

IS: 4332 (Part IX) - 1970

where

S = soluble binder content as in 14.1, and

T = percent by weight of binder soluble in the solvent employed.

14.3 Reporting of Results — If the difference between the results obtained by the duplicate determination exceeds 0.4, they shall be discarded and the test repeated. If the difference does not exceed 0.4, the individual values and the mean value shall be reported.



AMENDMENT NO. 1 AUGUST 1983

TO

IS:4332(Part IX)-1970 METHODS OF TEST FOR
STABILIZED SOILS

PART IX DETERMINATION OF THE BITUMINOUS STABILIZER
CONTENT OF BITUMEN AND TAR STABILIZED SOILS

Alterations

(Page 4, clause 2.1, lines 4, 6 and 8) - Substitute
'IS:460(Part I)-1978*' for 'IS:460-1962*'.
'

(Page 4, foot-note with '*' mark) - Substitute
the following for the existing foot-note:

'*Specification for test sieves: Part I Wire
cloth test sieves (second revision).'
'

(Pages 4 and 5, clause 3.8.1, line 6) - Substitute
'IS:460(Part I)-1978*' for 'IS:460-1962*'.
'

(Page 5, foot-note with '*' mark) - Substitute
the following for the existing foot-note:

'*Specification for test sieves: Part I Wire
cloth test sieves (second revision).'
'

(Page 8, clause 6.5, Note) - Substitute
'IS:1215-1978*' for 'IS:1215-1958*'.
'

(Page 8, foot-note with '*' mark) - Substitute
the following for the existing foot-note:

'*Specification for determination of matter
insoluble in toluene (first revision).'
'

(Page 13, clause 13.4, line 9) - Substitute
'IS:1215-1978*' for 'IS:1215-1958*'.
'



(Page 13, foot-note with '*' mark) - Substitute the following for the existing foot-note:

'*Specification for determination of matter insoluble in toluene (*first revision*).'

(BDC 23)