

IS : 3559 - 1966

Indian Standard
SPECIFICATION FOR
PNEUMATIC CONCRETE BREAKERS

(First Reprint OCTOBER 1990)

UDC 69.002.5:69.059.6:691.32

© Copyright 1982

BUREAU OF INDIAN STANDARDS
MANAK BHAVAN, 9 BAHADUR SHAH ZAFAR MARG
NEW DELHI 110002

Indian Standard

SPECIFICATION FOR PNEUMATIC CONCRETE BREAKERS

Construction Plant and Machinery Sectional Committee, BDC 28

<i>Chairman</i>	<i>Representing</i>
MAJ GEN R. A. LOOMBA	Engineer-in-Chief's Branch, Army Headquarters
<i>Members</i>	
SHRI R. S. BHALLA	Roads Wing, Ministry of Transport
SHRI A. B. CHAUDHURI	Jessop & Co Ltd, Calcutta
SHRI J. D. DAROGA	Italab Engineering Private Ltd, Bombay
SHRI A. D. DEINGRA	Heatly & Gresham Ltd, Calcutta
SHRI N. KUMAR (<i>Alternate</i>)	
DIRECTOR, CIVIL ENGINEERING	Railway Board (Ministry of Railways)
JOINT DIRECTOR (WORKS) (<i>Alternate</i>)	
SHRI H. C. GHULATI	Directorate General of Supplies & Disposals (Ministry of Works & Housing)
BRIG N. B. GRANT	Directorate General, Border Roads
SHRI M. A. HAFEEZ	National Buildings Organization (Ministry of Works & Housing)
SHRI K. S. SRINIVASAN (<i>Alternate</i>)	
SHRI S. Y. KHAN	Killick, Nixon & Co Ltd, Bombay
SHRI A. T. KOTHAVALA (<i>Alternate</i>)	
SHRI RAMESH KHANDELWAL	Khandelwal Udyog Ltd, Bombay
SHRI D. R. KOHLI	Burmah-Shell Oil Storage & Distributing Co of India Ltd, Bombay
SHRI M. R. MALYA (<i>Alternate</i>)	
SHRI K. M. KUMAR	Linkers Private Ltd, Patna
SHRI R. K. VARMA (<i>Alternate</i>)	
SHRI G. MARSHALL	Marshall Sons & Co Mfg Ltd, Madras
SHRI S. C. MAZUMDAR	Gannon Dunkerley & Co Ltd, Bombay
SHRI S. K. GUHA THAKURTA (<i>Alternate</i>)	
SHRI K. K. NAMBIAR	The Concrete Association of India, Bombay
SHRI C. V. NAZARETH (<i>Alternate</i>)	
BRIG M. N. PATEL	Research & Development Organization (Ministry of Defence)
MAJ A. P. R. RAO (<i>Alternate</i>)	
SHRI Y. G. PATEL	Builders Association of India, Bombay
SHRI H. J. SHAH (<i>Alternate</i>)	
BRIG S. N. PUNJ	Engineer-in-Chief's Branch, Army Headquarters
SHRI H. V. MIBCHANDANI (<i>Alternate</i>)	
SHRI RAJ KUMAR GAUTAM	William Jacks & Co Ltd, Calcutta
NARAYAN	
SHRI R. S. GADBOLE (<i>Alternate</i>)	

(Continued on page 2)

(Continued from page 1)

<i>Members</i>	<i>Representing</i>
SHRI G. S. ROVSHEN	Armstrong Smith Private Ltd, Bombay
SHRI U. G. KALYANPUR (Alternate)	
SHRI V. G. SAPTARISHI	Tata Engineering & Locomotive Co Ltd, Bombay
SENIOR ENGINEER	Hindustan Construction Co Ltd, Bombay
SHRI S. K. SINHA	Directorate General of Technical Development
SHRI B. C. SRIVASTAVA	Central Building Research Institute (CSIR), Roorkee
SHRI J. P. KAUSHIK (Alternate)	
DR BH. SUBBARAJU	Central Road Research Institute (CSIR), New Delhi
SUPERINTENDING ENGINEER,	Central Public Works Department
DELHI CENTRAL ELECTRICAL	
CIRCLE No. III	
EXECUTIVE ENGINEER (ELEC-	
TRICAL), MECHANICAL &	
WORKSHOP DIVISION (Alternate)	
SHRI N. H. TAYLOR	Recondo Ltd, Bombay
SHRI T. H. PESHORI (Alternate)	
SHRI V. K. YASHROY	Central Water & Power Commission
SHRI R. RAMASWAMY (Alternate)	
DR H. C. VISVESVARAYA,	Director General, ISI (<i>Ex-officio Member</i>)
Director (Civ Engg)	

Secretary

SHRI Y. R. TANEJA
Deputy Director (Civ Engg), ISI

Ad-hoc Panel for Pneumatic Concrete Breakers, BDC 28/P

Convener

BRIG N. B. GRANT Directorate General, Border Roads

Members

LT COL U. S. ANAND	Directorate of Engineering (R & D) (Ministry of Defence)
SHRI A. K. BANERJEE	Holman Climax Manufacturing Ltd, Calcutta
SHRI K. D. BISWAS	Dhakuria Engineering Works (Private) Ltd, Calcutta
SHRI V. G. DHAYAQUDE	Consolidated Pneumatic Tool Co (India) Ltd, Bombay
LT COL R. N. KANWAR	Engineer-in-Chief's Branch, Army Headquarters
SHRI N. V. MISHRAHANDANI	Atlas Copco (India) Private Ltd, Bombay
SHRI D. P. PANDYA (Alternate)	
SHRI B. C. SRIVASTAVA	Central Building Research Institute (CSIR), Roorkee

Indian Standard
**SPECIFICATION FOR
PNEUMATIC CONCRETE BREAKERS**

0. FOREWORD

0.1 This Indian Standard was adopted by the Indian Standards Institution on 26 April 1966, after the draft finalized by the Construction Plant and Machinery Sectional Committee had been approved by the Civil Engineering Division Council.

0.2 Hand-held pneumatic concrete breakers have a wide variety of uses in general construction, demolition work and in industrial plants. Breakers of heavy class are used for breaking concrete pavements, demolition of concrete foundations and walls, cutting pavements and sub-bases, trenching in hard ground and for breaking boulders which cannot be otherwise blasted. Breakers of medium class are suitable for breaking light concrete pavements and floors, macadam, frozen ground and gravel. Breakers of light class are useful in light demolition work on floors, pavements and masonry walls. Light breakers are particularly suitable for jobs requiring the operator to handle the tools continuously and for work which is required to be carried out close to existing structures. This standard has been prepared with a view to providing guidance to manufacturers and users in obtaining concrete pneumatic breakers capable of giving satisfactory performance.

0.3 Heavy class breakers can be converted into sheeting drivers, heavy and medium breakers can also be converted into railway spike drivers by substituting a spike-driver head in place of the regular front head.

0.4 Moil points can be substituted by various other breaking tools, such as narrow and wide chisels, digging blades, frost wedges, asphalt cutters, clay spades and scoops, tamping pads, and pipe or sheeting driver heads.

0.5 The dimensions of tool shanks for pneumatic concrete breakers have been specified on the basis of current manufacturing practices in the country. Standards on shanks for all pneumatic tools are, however, under preparation and it is proposed to review the dimensions specified in this standard when a separate standard on the subject becomes available.

0.6 This standard contains clause **5.4** which permits the purchaser to use his option for selection to suit his requirement, and clauses **9.1.1**, **10.1.2** and **10.1.3** which call for agreement between the purchaser and the supplier.

0.7 In the formulation of this standard due weightage has been given to international co-ordination among the standards and practices prevailing in different countries in addition to relating it to the practices in this field in this country.

0.8 For the purpose of deciding whether a particular requirement of this standard is complied with, the final value, observed or calculated, expressing the result of a test or analysis, shall be rounded off in accordance with IS : 2-1960*. The number of significant places retained in the rounded off value should be the same as that of the specified value in this standard.

1. SCOPE

1.1 This standard lays down the requirements for sizes, dimensions and performance of concrete pneumatic breakers.

2. TERMINOLOGY

2.0 For the purpose of this standard, the following definitions shall apply.

2.1 Concrete Breaker — A heavy or medium weight percussive tool used for demolition work.

2.2 Percussive Tool — A tool in which the piston reciprocates in a cylinder and gives a blow at one end of its stroke.

2.3 Pneumatic Hand Tools — Any percussive and/or rotary tool.

2.4 Routine Tests — Tests carried out on each pneumatic breaker to ascertain that it conforms to the physical and performance requirements as laid down in this standard.

2.5 Type Tests — Tests carried out on a type pneumatic breaker to verify conformity to the performance requirements laid down in this standard.

3. MATERIALS

3.1 All materials used in the construction of pneumatic concrete breakers shall conform to the requirements of relevant Indian Standards.

4. SIZES

4.1 Pneumatic concrete breakers shall be classified according to their weight as under:

- | | |
|-----------|----------------------------|
| a) Light | Up to 20 kg |
| b) Medium | Over 20 kg and up to 32 kg |
| c) Heavy | Over 32 kg and up to 40 kg |

NOTE — All weights shall be of the basic tool without any attachment or accessory.

*Rules for rounding off numerical values (*revised*).

5. CONSTRUCTION

5.1 General— The breaker shall consist of a back head equipped with a handle, a cylinder assembly, and a throttle; and a front head equipped with a chuck for the collar shanked tools of dimensions given in Fig 1. Unless otherwise specified, the handle shall be a T-handle.

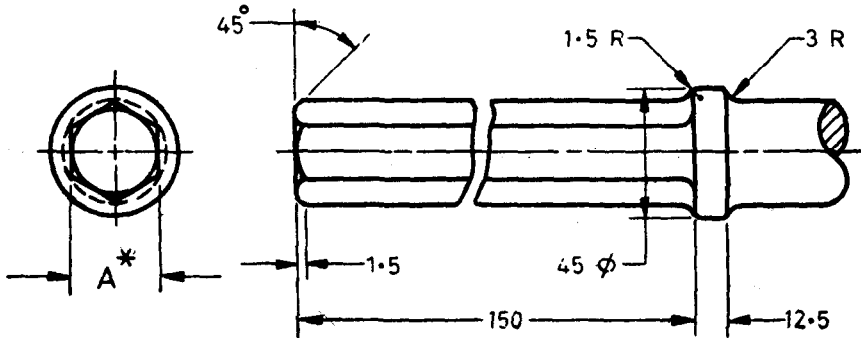

*A = 28.00 ± 0.25 for light and medium breaker, and
32.00 ± 0.30 for heavy breaker.

All dimensions in millimetres.

FIG. 1 DIMENSIONS OF TOOL SHANKS FOR PNEUMATIC CONCRETE BREAKER

5.2 Back Head Assembly— The back head assembly shall consist of a housing of forged steel or any other equally suitable material, a T-handle and a throttle lever. The throttle lever shall be located to permit operation of the breaker from either side.

5.2.1 Cylinder Assembly— The cylinder assembly shall consist of a forged steel or any other equally suitable material, a valve mechanism to control the direction of air required for actuation of the piston, an anvil block sleeve and a reversible piston.

5.2.2 Flanges— All flanges shall have sufficient thickness and strength to prevent failure during operation and to withstand mechanical stress when back head and front head assemblies are installed.

5.3 The front head assembly shall consist of a chuck housing of forged steel or any other equally suitable material, a chuck for collar shank tools of dimensions given in Fig. 1 and a positive shank retaining device, such as latch retainer or swing stirrup type spring retainer. The chuck housing of the breaker shall contain a renewable liner or shall be of solid type.

5.4 Air Inlet Connection — The air inlet connection shall permit operation of the breaker without any obstruction to the normal working or any restraint on the operator. If so required by the purchaser, swivel type air inlet connection may be provided. The end of the air inlet connection shall have an extended thread and shall be provided with a nipple suitable for connection to 20-mm air hose.

5.5 Exhaust Port — The exhaust port shall be located to direct exhaust air downward and away from the operator when the breaker is operated from either side.

5.6 Air Cushion — The cylinder shall have a suitable air cushion at both ends of the piston stroke.

5.7 Lubrication — All surfaces requiring lubrication shall be provided with means for lubrication through the use of either an internal oil reservoir or an air line oiler. When an oil reservoir is furnished, it shall have a capacity of not less than 25 minutes of continuous operation while operating at 6.5 kg/cm² gauge pressure at the tool.

6. WORKMANSHIP

6.1 The breaker shall be free from defects resulting from contact of dissimilar metals, rust, cracks, incomplete welds and other defects that could impair its operation or serviceability. All parts, components, and assemblies including castings, forgings, moulded parts, stampings, bearings, seals, machine surfaces, and welded parts shall be cleaned free of sand, dirt, fins, pits, sprues, scales, flux, and other harmful or extraneous materials. External surfaces shall be smooth and all edges shall be rounded or bevelled.

7. SAFETY REQUIREMENTS

7.1 The breaker shall be provided with a positive lock which will prevent the accessory from becoming accidentally disengaged from the breaker. It shall be fitted with vibration resisting equipment and shall be so designed that the vibrations and recoil under working condition are within the limits specified in relevant safety regulations.

8. PERFORMANCE CHARACTERISTICS

8.1 The breaker shall be operable in any position. Performance characteristics of the breaker, when tested in accordance with **8.2** to **8.5** shall conform to the requirement given in Table 1.

8.2 Operational Test — The breaker shall be operated with 5 to 7 kg/cm² gauge air pressure at the tool for not less than 100 hours for breaking cement concrete. Inability of the breaker to complete this test, or the

presence of any of the following defects during operation shall constitute failure of this test:

- a) Accessory accidentally disengages from the breaker,
- b) Absence of oil vapour in the exhaust air,
- c) Air supply hose interferes with operator when breaker is operated in all possible positions,
- d) Evidence of damage to, or permanent deformation or breakage of any component or part,
- e) Exhaust air is not directed downward and away from the operator, and
- f) Oil reservoir, when furnished, has less than 25 minutes continuous operational capacity at 6.5 kg/cm^2 gauge air pressure at the tool.

8.2.1 When furnished, the spike driver and sheeting driver shall be operated for not less than 10 hours each. The spike driver shall drive railroad spikes and the sheeting driver shall drive planks of 50 mm and 75 mm thickness. Failure of the breaker to convert to and operate as a spike driver and a sheeting driver shall constitute failure of this test.

8.3 Temperature Humidity Test — For this test, the supply air for the compressor shall be obtained from the ambient temperature at which the test is being conducted. The breaker shall be subjected to an ambient temperature of $-1^\circ\text{C} \pm 0.5^\circ\text{C}$ at relative humidity of not less than 98 percent until the oil in the lubricator is stabilized at $-1^\circ\text{C} \pm 0.5^\circ\text{C}$. The breaker shall be operated for not less than 10 minutes. Any adjustments required shall be accomplished during this 10-minute operating period. The breaker shall then be operated for not less than one hour at $-1^\circ\text{C} \pm 0.5^\circ\text{C}$ and at a relative humidity of not less than 98 percent for breaking concrete or performing other demolition work. After this one hour operation, the breaker shall be disassembled and examined. Failure of the breaker to operate properly, inability to break concrete or perform other demolition work, evidence of excessive wear, or failure of any component shall constitute failure of this test.

8.4 Air-Consumption Test — The water displacement meter or any other equally suitable instrument shall be used to determine the quantity of air consumed per minute at 6.5 kg/cm^2 gauge air pressure on the tool while the pellet test is performed as specified in 8.5. Air consumption in excess of that specified in Table 1 shall constitute failure of the breaker in this test.

8.5 Force of Blow (Pellet Test)

8.5.1 The force of blow of the breaker shall be measured by pellet test. This consists in operating the breaker for a specified period to beat down a cylindrical test piece (pellet) of steel of known tensile strength and machined to close limits, and measuring the reduction in length of the pellet.

TABLE 1 PHYSICAL AND PERFORMANCE CHARACTERISTICS

(Clause 8.1)

Sl No.	CHARACTERISTICS	LIGHT BREAKER	MEDIUM BREAKER	HEAVY BREAKER	TEST REQUIREMENTS	REMARKS
i)	Piston speed (under no load), blows per minute	1550-1650	1250-1350	1100-1250	The measured piston speed shall be within the limits specified in this table and shall not vary by more than ± 5 per cent of the value stipulated by the manufacturer	Routine test
ii)	Operational test	—	—	—	Shall comply with the requirements of 8.2	Type test
iii)	Temperature humidity test	—	—	—	Shall comply with the requirements of 8.3	Type test (see 9.1.1)
iv)	Air consumption (at 6.5 kg/cm ² gauge pressure at tool) l/min, Max	1330	1925	2490	When tested in accordance with 8.4 and 8.5 air consumption shall be below the values specified in this table and within ± 2 percent of the value stipulated by the manufacturer	Routine test
v)	Pellet test, compression of pellet, mm, Min	5	3	5.1	When tested in accordance with 8.5, the compression of the pellet shall not be less than the value specified in this table	Routine test

8.5.2 The test gear shall consist of a firm and solid steel base upon which a removable substantial pot with hardened steel bush and having a vertical opening of 32 mm diameter is mounted with dowels. Typical details of a suitable solid base are given in Fig. 2, though any other suitable firm and solid base may be used by agreement between the purchaser and the supplier.

8.5.3 The breaker shall be fitted with a blank steel plunger 30 mm in diameter, approximately 2.15 kg in weight and hardened to RC-55 throughout. The shank dimensions of the plunger shall conform to Fig. 1.

8.5.3.1 The cylindrical test piece (pellet) of mild steel of 44-55 kg/mm² tensile strength and of hardness RB 85-90, and of dimensions indicated below shall be vertically placed in position in the pot of the impact testing machine.

<i>Breaker</i>	<i>Pellet</i>	
	<i>Dia</i>	<i>Length</i>
	mm	mm
Light	14.3 $\begin{smallmatrix} +0.00 \\ -0.05 \end{smallmatrix}$	14.3 $\begin{smallmatrix} +0.00 \\ -0.025 \end{smallmatrix}$
Medium	25.4 $\begin{smallmatrix} +0.00 \\ -0.05 \end{smallmatrix}$	25.4 $\begin{smallmatrix} +0.00 \\ -0.025 \end{smallmatrix}$
Heavy	25.4 $\begin{smallmatrix} +0.00 \\ -0.05 \end{smallmatrix}$	25.4 $\begin{smallmatrix} +0.00 \\ -0.025 \end{smallmatrix}$

The breaker shall be placed in position so that the blank steel plunger rests on the upper end of the pellet. The breaker shall then be operated in hand held position for 5 seconds (measured with a stop watch) at 6.5 kg/cm² gauge air pressure. The breaker and the plunger shall then be released and the pellet withdrawn from the pot.

8.5.3.2 The compression (reduction in length) of the pellet shall be measured by means of a micrometer and reported.

9. TESTS

9.1 Type Tests — The following shall constitute the type tests:

- a) Operational test (*see 8.2*), and
- b) Temperature-humidity test (*see 8.3*).

9.1.1 Temperature humidity test shall be optional type test depending upon the agreement between the purchaser and the supplier and applicable only to breakers for use at high altitudes and very low temperatures.

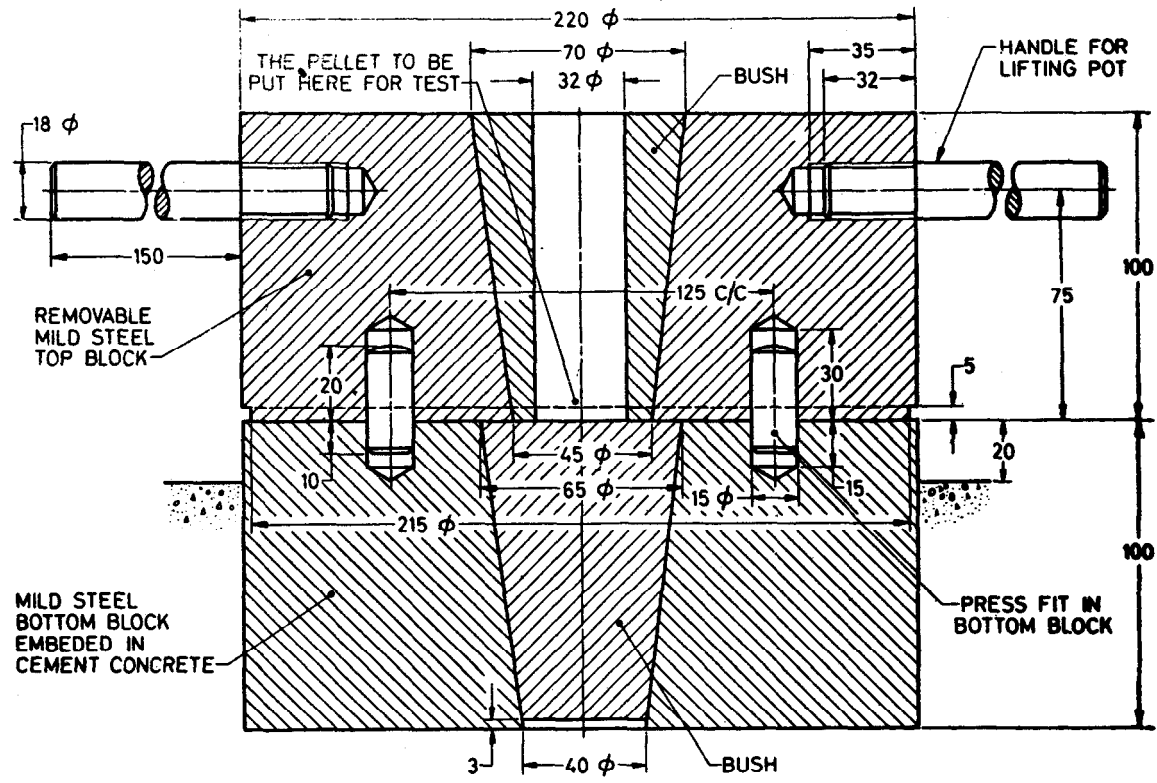

NOTE — Bushes shall be made from high carbon shock resisting water hardening steel, hardened to 60-61 RC
 All dimensions in millimetres.

FIG. 2 TYPICAL DETAILS OF SOLID BASE FOR PELLET TEST

9.2 Routine Tests — The following shall constitute the routine tests:

- a) Piston speed test,
- b) Air-consumption test, and
- c) Pellet test.

9.3 If so specified, when inviting tenders, tests shall be carried out at the manufacturer's works in the presence of purchaser or his representative to ensure that the breaker conforms to the requirements of this standard and complies with the routine tests indicated in **9.2**. In the case when a batch of 30 or more similar breakers is supplied to one order, type tests, as specified, shall be made on one of these breakers, if the purchaser so requires.

9.4 Test Certificates

9.4.1 Unless otherwise specified when inviting tenders, the purchaser, if so desired by the manufacturer, shall accept as evidence of the compliance of the breaker with the requirements of **8**, tests on a breaker identical in essential details with the one purchased, together with routine tests on each individual breaker.

9.4.2 Certificates of routine tests shall show that the breaker purchased has been run and has been found to be sound and in working order in all respects as specified in this standard.

9.4.3 Certificates showing records of all type tests carried out on the breaker, shall be kept available by the manufacturer for inspection.

10. ACCESSORIES AND ATTACHMENTS

10.1 Accessories — When so specified by the purchaser, the following accessories shall be supplied with the breaker:

- a) Chisel,
- b) Moil point,
- c) Tamping pad,
- d) Tamping rod, and
- e) Air line oiler.

10.1.1 Chisel and Moil Point — The chisel and moil point shall be made of forged steel or any other equivalent material. They shall be supplied as normalized hardened and tempered to a hardness of minimum RC 55 throughout its length so that the hardness may be subsequently improved by user as per his requirements.

10.1.1.1 Dimensions — Unless otherwise agreed to between the purchaser and the supplier, the chisel and moil point shall have a length of

IS : 3559 - 1966

350 \pm 12.5 mm exclusive of the shank and collar and the chisels shall have a cutting edge width of 75 \pm 3 mm.

10.1.2 Tamping Rod — The tamping rod shall be made of forged steel conforming to relevant Indian Standards and shall be of a suitable shape as agreed to between the purchaser and the supplier (see Note under 10.1.3).

10.1.3 Tamping Pad — The tamping pad shall be of cast steel and shall be of a suitable shape agreed to between the purchaser and the supplier (see Note). The weight of the tamping pad shall be not less than 6 kg.

NOTE—Suitable shapes of tamping rod and tamping pad generally in common use are given in Fig. 3.

10.2 Attachments — When so specified by the purchaser the following attachments shall be furnished with the breaker:

- a) Spike driver, and
- b) Sheeting driver.

10.2.1 Spike Driver — The medium and heavy breaker shall be convertible for use as a spike driver by replacement of the standard front head with a front head constructed specifically for driving railroad spikes.

10.2.2 Sheeting Driver — The medium and heavy breaker shall be convertible for use as a sheeting driver by replacement of the standard front head with a front head constructed specifically for driving sheeting and planks. The sheeting driver shall be of forged steel and shall be adjustable for driving 50 to 75 mm planks.

11. TOOLS

11.1 Maintenance and operating tools and tools required for normal running adjustments and lubrication shall be provided with the pneumatic breaker along with necessary instructions.

12. PAINTING

12.1 All exposed parts shall be cleaned and given suitable anti-corrosive treatment and protection.

13. MARKING

13.1 Each pneumatic breaker shall have the following information suitably marked on it:

- a) Manufacturer's name and trade-mark,
- b) Pneumatic breaker reference number,

TAPER SHALL BE SMOOTH AND ACCURATE TO FIT PAD

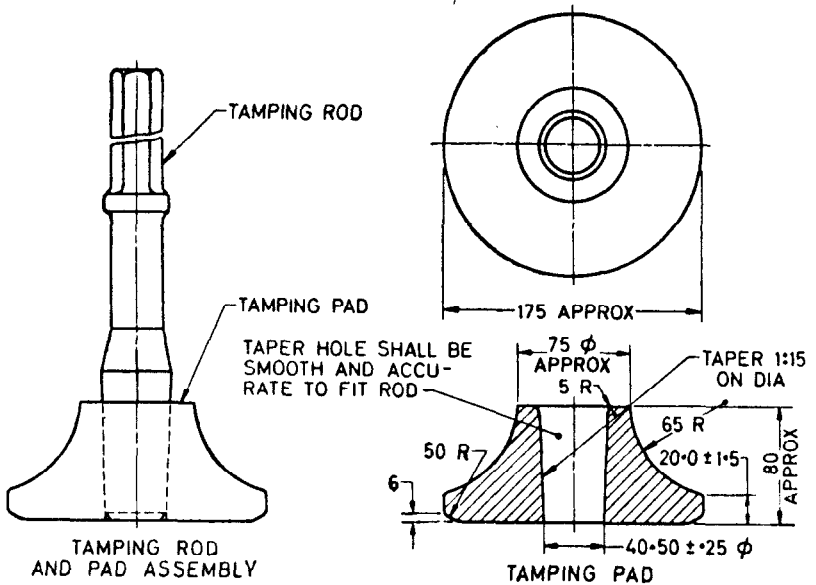
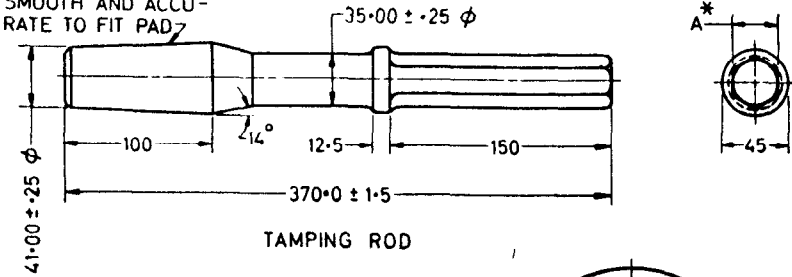

*A = 28.00 ± 0.25 for light and medium breaker, and
32.00 ± 0.30 for heavy breaker.

All dimensions in millimetres.

FIG. 3 TYPICAL DETAILS OF TAMPING ROD AND PAD

- c) Weight of the pneumatic breaker,
- d) Maximum air consumption (*see* Table 1 and **8.2**), and
- e) Operating pressure.

13.1.1 The pneumatic concrete breaker may also be marked with the ISI Certification Mark.

NOTE — The use of the ISI Certification Mark is governed by the provisions of the Indian Standards Institution (Certification Marks) Act, and the Rules and Regulations made thereunder. Presence of this mark on products covered by an Indian Standard conveys the assurance that they have been produced to comply with the requirements of that standard, under a well-defined system of inspection, testing and quality control during production. This system, which is devised and supervised by ISI and operated by the producer, has the further safeguard that the products as actually marketed are continuously checked by ISI for conformity to the standard. Details of conditions, under which a licence for the use of the ISI Certification Mark may be granted to manufacturers or processors, may be obtained from the Indian Standards Institution.

BUREAU OF INDIAN STANDARDS

Headquarters:

Manak Bhavan, 9 Bahadur Shah Zafar Marg, NEW DELHI 110002

Telephones: 331 01 31, 331 13 75

Telegrams: Manaksanstha
(Common to all Offices)

Regional Offices:

	<i>Telephone</i>
Central : Manak Bhavan, 9 Bahadur Shah Zafar Marg, NEW DELHI 110002	{ 331 01 31 331 13 75
*Eastern : 1/14 C. I. T. Scheme VII M, V. I. P. Road, Maniktola, CALCUTTA 700054	36 24 99
Northern : SCO 445-446, Sector 35-C, CHANDIGARH 160036	{ 2 18 43 3 16 41 41 24 42
Southern : C. I. T. Campus, MADRAS 600113	{ 41 25 19 41 29 16
†Western : Manakalaya, E9 MIDC, Marol, Andheri (East), BOMBAY 400093	6 32 92 95

Branch Offices:

'Pushpak', Nurmohamed Shaikh Marg, Khanpur, AHMADABAD 380001	{ 2 63 48 2 63 49
‡Peenya Industrial Area 1st Stage, Bangalore Tumkur Road BANGALORE 560058	{ 38 49 55 38 49 56
Gangotri Complex, 5th Floor, Bhadbhada Road, T. T. Nagar, BHOPAL 462003	6 67 16
Plot No. 82/83, Lewis Road, BHUBANESHWAR 751002	5 36 27
53/5 Ward No. 29, R.G. Barua Road, 5th Byelane, GUWAHATI 781003	3 31 77
5-8-56C L. N. Gupta Marg (Nampally Station Road). HYDERABAD 500001	23 10 83
R14 Yudhister Marg, C Scheme, JAIPUR 302005	{ 6 34 71 6 98 32
117/418 B Sarvodaya Nagar, KANPUR 208005	{ 21 68 76 21 82 92
Patliputra Industrial Estate, PATNA 800013	6 23 05
T.C. No. 14/1421, University P.O., Palayam TRIVANDRUM 695035	{ 6 21 04 6 21 17

Inspection Offices (With Sale Point):

Pushpanjali, First Floor, 205-A West High Court Road, Shankar Nagar Square, NAGPUR 440010	2 51 71
Institution of Engineers (India) Building, 1332 Shivaji Nagar, PUNE 411005	5 24 35

*Sales Office in Calcutta is at 5 Chowringhee Approach, P. O. Princep 27 68 00
Street, Calcutta 700072

†Sales Office in Bombay is at Novelty Chambers, Grant Road, 89 65 28
Bombay 400007

‡Sales Office in Bangalore is at Unity Building, Narasimharaja Square, 22 36 71
Bangalore 560002

Reprography Unit, B.I., New Delhi, India

AMENDMENT NO. 1 OCTOBER 1976
TO
IS : 3559-1966 SPECIFICATION FOR PNEUMATIC
CONCRETE BREAKERS

Alterations

(*Page 3, clause 0.5*) — Delete the clause and re-number clauses ' 0.6, 0.7 and 0.8 ' as ' 0.5, 0.6 and 0.7 ' respectively.

(*Page 5, clause 5.1*) — Substitute the following for the existing clause:

5.1 General — The breaker shall consist of a back head equipped with a handle, a cylinder assembly, and a throttle; and a front head equipped with a chuck for the pneumatic concrete breaker shanks conforming to IS : 7995-1976* and having width across flats as 28.5 mm in case of light and medium breakers and 31.7 mm in case of heavy breakers. Unless otherwise specified, the handle shall be a T-handle.'

(*Page 5, Fig. 1*) — Delete Fig. 1 and re-number ' Fig. 2 and 3 ' as ' Fig. 1 and Fig. 2 ' respectively wherever they occur.

(*Page 5, clause 5.3*) — Substitute the following for the existing clause:

5.3 The front head assembly shall consist of a chuck housing of forged steel or any other equally suitable material, a chuck suitable for pneumatic concrete breaker shanks conforming to IS : 7995-1976* and a positive shank retaining device, such as latch retainer or swing stirrup type spring retainer. The chuck housing of the breaker shall contain a renewable liner or shall be of solid type.'

(*Page 5, clause 5.3*) — Add the following foot-note at the bottom of the page:

'*Dimensions for pneumatic concrete breaker shanks.'

(*Page 9, clause 8.5.3, last sentence*) — Substitute the following for the existing sentence:

'The shank dimensions of the plunger shall conform to IS : 7995-1976* and shall have width across flats as 28.5 mm in case of light and medium breakers and 31.7 mm in case of heavy breakers.'

(*Page 9, clause 9.1.1*) — Add the following foot-note at the bottom of the page:

'*Dimensions for pneumatic concrete breaker shanks.'

[Page 13, Fig. 3 (re-numbered as Fig. 2), Fig. for Tamping Rod] — Delete the dimensions 12.5, 150 and 45 and substitute the following for the existing foot-note marked with an asterisk:

*A (width across flats) = 28.5 for light and medium breakers and 31.7 for heavy breakers } Conforming to IS: 7995-1976†

[Page 13, Fig. 3 (re-numbered as Fig. 2)] — Add the following foot-note at the bottom of the page:

†Dimensions for pneumatic concrete breaker shanks.