

भारतीय मानक

निर्माण के लिए पक्की मिट्टी की ईंटों की परीक्षण पद्धति

भाग 1 संपीडन सामर्थ्य ज्ञात करना

भाग 2 जल अवशोषण ज्ञात करना

भाग 3 उत्फुल्लन ज्ञात करना

भाग 4 विकृचता ज्ञात करना

(तीसरा पुनरीक्षण)

Indian Standard

**METHODS OF TESTS OF BURNT CLAY
BUILDING BRICKS**

PART 1 DETERMINATION OF COMPRESSIVE STRENGTH

PART 2 DETERMINATION OF WATER ABSORPTION

PART 3 DETERMINATION OF EFFLORESCENCE

PART 4 DETERMINATION OF WARPAGE

(*Third Revision*)

Third Reprint OCTOBER 1998

UDC 666 712 · 620·1

© BIS 1992

**BUREAU OF INDIAN STANDARDS
MANAK BHAVAN, 9 BAHADUR SHAH ZAFAR MARG
NEW DELHI 110002**

FOREWORD

This Indian Standard (Parts 1 to 4) (Third Revision) was adopted by the Bureau of Indian Standards, after the draft finalized by the Clay Products for Buildings Sectional Committee had been approved by the Civil Engineering Division Council.

This standard covering methods of tests was first published in 1966 and subsequently revised in 1973 and 1976. This revision has been prepared so as to bring in line with the latest Indian Standards on bricks. Opportunity has also been taken to up-to-date the contents.

In reporting the results of a test made in accordance with this standard, if the final value, observed or calculated, is to be rounded off, it shall be done in accordance with IS 2 : 1960 'Rules for rounding off numerical values (*revised*)'.

*Indian Standard***METHODS OF TESTS OF BURNT CLAY BUILDING BRICKS****PART 1 DETERMINATION OF COMPRESSIVE STRENGTH***(Third Revision)***1 SCOPE**

1.1 This standard (Part 1) covers the method of determination of compressive strength of burnt clay building bricks.

2 REFERENCE

2.1 The Indian Standard IS 5454 : 1976 'Method for sampling of clay building bricks (first revision)' is a necessary adjunct to this standard.

3 GENERAL

3.1 The dimensions shall be measured to the nearest 1 mm.

3.2 All apparatus and testing equipment shall be calibrated at frequent intervals.

3.3 The number of specimens for the test shall be selected according to IS 5454 : 1976.

4 METHODS**4.1 For Solid Bricks****4.1.1 Apparatus**

A compression testing machine, the compression plate of which shall have a ball seating in the form of portion of a sphere the centre of which coincides with the centre of the plate, shall be used.

4.1.2 Preconditioning

Remove unevenness observed in the bed faces to provide two smooth and parallel faces by grinding. Immerse in water at room temperature for 24 hours. Remove the specimen and drain out any surplus moisture at room temperature. Fill the frog (where provided) and all voids in the bed face flush with cement mortar (1 cement, clean coarse sand of grade 3 mm and down). Store under the damp jute bags for 24 hours followed by immersion in clean water for 3 days. Remove, and wipe out any traces of moisture.

4.1.3 Procedure

Place the specimen with flat faces horizontal, and mortar filled face facing upwards between two 3-ply plywood sheets each of 3 mm thickness and carefully centred between plates of the testing machine. Apply load axially at a uniform rate of 14 N/mm² (140 kgf/cm²) per minute till failure occurs and note the maximum load at failure. The load at failure shall be the maximum load at which the specimen fails to produce any

further increase in the indicator reading on the testing machine.

NOTE — In place of plywood sheets plaster of Paris may be used to ensure a uniform surface for application of load.

4.1.4 Report

The report shall be as given below:

Compressive strength in N/mm²
 (kgf/cm²) = $\frac{\text{Maximum load at failure in N(kgf)}}{\text{Average area of the bed faces in mm}^2 \text{ (cm}^2 \text{)}}$

4.1.4.1 The average of results shall be reported.

4.2 For Perforated Bricks**4.2.1 Apparatus**

See 4.1.1.

4.2.2 Preconditioning

Immerse the specimen in water at room temperature for 24 hours. Remove the specimen from water and drain out any surplus water. No mortar shall be filled in perforations and no mortar capping shall be provided.

4.2.3 Procedure

Place the perforated faces of the brick between two 3-ply plywood sheets each of 3 mm thickness and carefully centred between the plates of the testing machine. Apply the load axially at uniform rate of 14 N/mm² (140 kgf/cm²) per minute till the failure occurs and note the maximum load at failure. The load at failure shall be the maximum load at which the specimen fails to produce any further increase in the indicator reading on the testing machine.

NOTE — In place of plywood sheets plaster of Paris may be used to ensure a uniform surface for application of load.

4.2.4 Report

The report shall be as given below:

Compressive strength in N/mm²
 (kgf/cm²) = $\frac{\text{Maximum load at failure in N (kgf)}}{\text{Average net area of the two faces under compression in mm}^2 \text{ (cm}^2 \text{)}}$

4.2.4.1 The average of results shall be reported.

As in the Original Standard, this Page is Intentionally Left Blank

*Indian Standard***METHODS OF TESTS OF BURNT CLAY
BUILDING BRICKS****PART 2 DETERMINATION OF WATER ABSORPTION***(Third Revision)***1 SCOPE**

1.1 This standard (Part 2) covers the method of determination of water absorption of burnt clay building bricks.

2 REFERENCE

2.1 The Indian Standard IS 5454 : 1976 'Method for sampling of clay building bricks (*first revision*)' is a necessary adjunct to this standard.

3 GENERAL

3.1 The dimension shall be measured to the nearest 1 mm.

3.2 All apparatus and testing equipment shall be calibrated at frequent intervals.

3.3 The number of specimens for the test shall be selected according to IS 5454 : 1976.

4 METHODS**4.1 24-hour Immersion Cold Water Test****4.1.1 Apparatus**

A sensitive balance capable of weighing within 0.1 percent of the mass of the specimen; and a ventilated oven.

4.1.2 Preconditioning

Dry the specimen in a ventilated oven at a temperature of 105 to 115°C till it attains substantially constant mass. Cool the specimen to room temperature and obtain its weight (M_1). Specimen warm to touch shall not be used for the purpose.

4.1.3 Procedure

Immerse completely dried specimen in clean water at a temperature of $27 \pm 2^\circ\text{C}$ for 24 hours. Remove the specimen and wipe out any traces of water with a damp cloth and weigh the specimen. Complete the weighing 3 minutes after the specimen has been removed from water (M_2).

4.1.4 Water absorption, percent by mass, after 24-hour immersion in cold water is given by the following formula:

$$\frac{M_2 - M_1}{M_1} \times 100$$

As in the Original Standard, this Page is Intentionally Left Blank

*Indian Standard***METHODS OF TESTS OF BURNT CLAY
BUILDING BRICKS****PART 3 DETERMINATION OF EFFLORESCENCE***(Third Revision)***1 SCOPE**

1.1 This standard (Part 3) covers the method of determination of efflorescence of burnt clay building bricks.

2 REFERENCE

2.1 The Indian Standard IS 5454 : 1976 'Method for sampling of clay building bricks (*first revision*)' is a necessary adjunct to this standard.

3 GENERAL

3.1 The dimensions shall be measured to the nearest 1 mm.

3.2 All apparatus and testing equipment shall be calibrated at frequent intervals.

3.3 The number of specimens for the test shall be selected according to IS 5454 : 1976.

4 METHOD**4.1 Apparatus**

A shallow flat bottom dish containing sufficient distilled water to completely saturate the specimens. The dish shall be made of glass, porcelain or glazed stoneware and of size 180 mm × 180 mm × 40 mm depth for square shaped and 200 mm dia × 40 mm depth for cylindrical shaped.

4.2 Procedure

Place the end of the bricks in the dish, the depth of immersion in water being 25 mm. Place the

whole arrangement in a warm (for example, 20 to 30°C) well ventilated room until all the water in the dish is absorbed by the specimens and the surplus water evaporates. Cover the dish containing the brick with suitable glass cylinder so that excessive evaporation from the dish may not occur. When the water has been absorbed and bricks appear to be dry, place a similar quantity of water in the dish and allow it to evaporate as before. Examine the bricks for efflorescence after the second evaporation and report the results.

4.3 Report

The liability to efflorescence shall be reported as 'nil', 'slight', 'moderate', 'heavy' or 'serious' in accordance with the following definitions:

- a) *Nil* — When there is no perceptible deposit of efflorescence.
- b) *Slight* — When not more than 10 percent of the exposed area of the brick is covered with a thin deposit of salts.
- c) *Moderate* — When there is a heavier deposit than under 'slight' and covering up to 50 percent of the exposed area of the brick surface but unaccompanied by powdering or flaking of the surface.
- d) *Heavy* — When there is a heavy deposit of salts covering 50 percent or more of the exposed area of the brick surface but unaccompanied by powdering or flaking of the surface.
- e) *Serious* — When there is a heavy deposit of salts accompanied by powdering and/or flaking of the exposed surfaces.

As in the Original Standard, this Page is Intentionally Left Blank

Indian Standard

METHODS OF TESTS OF BURNT CLAY BUILDING BRICKS

PART 4 DETERMINATION OF WARPAGE

(Third Revision)

1 SCOPE

1.1 This standard (Part 4) covers the method of determination of warpage of burnt clay building bricks.

2 REFERENCE

2.1 The Indian Standard IS 5454 : 1976 'Method for sampling of clay building bricks (first revision)' is a necessary adjunct to this standard.

3 GENERAL

3.1 The dimension shall be measured to the nearest 1 mm.

3.2 All apparatus and testing equipment shall be calibrated at frequent intervals.

3.3 The number of specimens for the test shall be selected according to IS 5454 : 1976.

4 METHOD

4.1 Measuring Instrument

- a) A steel rule graduated from one end in 0.5 mm divisions. Alternatively, a steel measuring wedge 60 mm in length, 15 mm in width and 15 mm in thickness at one end and tapered, starting at a line 15 mm from one end to zero thickness at the other end.

The wedge shall be graduated in 0.5 mm divisions and numbered to show the thickness of the wedge between the base *AB* and the slope *AC* (see Fig. 1).

- b) A flat surface of steel or glass, not less than 300 mm × 300 mm in area and plane to 0.02 mm.

4.2 Preconditioning

Remove any dirt adhering to the surface of brick.

4.3 Testing

4.3.1 For Concave Warpage

Place the flat surface along the surface to be measured selecting the location that gives the greatest departure from straightness. Measure the greatest distance of the brick surface from the edge of straightness by a steel rule or wedge.

4.3.2 For Convex Warpage

Place the brick on the flat surface with the convex surface in contact with the flat surface. Measure the distance from flat surface to the four corners of the brick, and take the maximum of four measurements.

4.4 Report

The higher of the distance measured in 4.3.1 and 4.3.2 shall be reported as warpage.

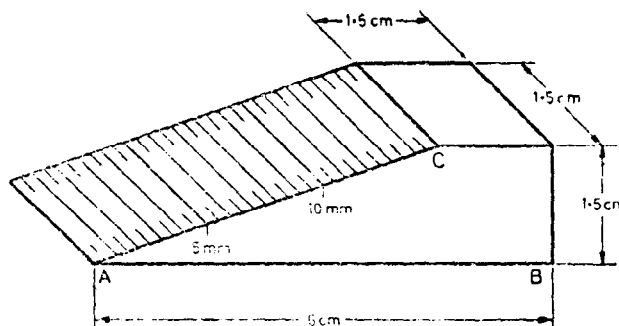

FIG. 1 MEASURING WEDGE

Bureau of Indian Standards

BIS is a statutory institution established under the *Bureau of Indian Standards Act, 1986* to promote harmonious development of the activities of standardization, marking and quality certification of goods and attending to connected matters in the country.

Copyright

BIS has the copyright of all its publications. No part of these publications may be reproduced in any form without the prior permission in writing of BIS. This does not preclude the free use, in the course of implementing the standard, of necessary details, such as symbols and sizes, type or grade designations. Enquiries relating to copyright be addressed to the Director (Publication), BIS.

Review of Indian Standards

Amendments are issued to standards as the need arises on the basis of comments. Standards are also reviewed periodically; a standard along with amendments is reaffirmed when such review indicates that no changes are needed; if the review indicates that changes are needed, it is taken up for revision. Users of Indian Standards should ascertain that they are in possession of the latest amendments or edition by referring to the latest issue of 'BIS Handbook' and 'Standards Monthly Additions'.

This Indian Standard has been developed from Doc: No. CED 30 (5017)

Amendments Issued Since Publication

Amend No.	Date of Issue	Text Affected

BUREAU OF INDIAN STANDARDS

Headquarters:

Manak Bhavan, 9 Bahadur Shah Zafar Marg, New Delhi 110002
Telephones: 323 01 31, 323 33 75, 323 94 02

Telegrams: Manaksanstha
(Common to all offices)

Regional Offices:

Telephone

Central : Manak Bhavan, 9 Bahadur Shah Zafar Marg
NEW DELHI 110002

323 76 17, 323 38 41

Eastern : 1/14 C.I.T. Scheme VII M, V.I.P. Road, Maniktola
CALCUTTA 700054

{ 337 84 99, 337 85 61
{ 337 86 26, 337 91 20

Northern : SCO 335-336, Sector 34-A, CHANDIGARH 160022

{ 60 38 43
{ 60 20 25

Southern : C.I.T. Campus, IV Cross Road, CHENNAI 600113

{ 235 02 16, 235 04 42
{ 235 15 19, 235 23 15

Western : Manakalaya, E9 MIDC, Marol, Andheri (East)
MUMBAI 400093

{ 832 92 95, 832 78 58
{ 832 78 91, 832 78 92

Branches : AHMADABAD. BANGALORE. BHOPAL. BHUBANESHWAR.
COIMBATORE. FARIDABAD. GHAZIABAD. GUWAHATI.
HYDERABAD. JAIPUR. KANPUR. LUCKNOW. NAGPUR.
PATNA. PUNE. THIRUVANANTHAPURAM.