

IS : 2974 (Part IV) - 1979

(Reaffirmed 1995)

Indian Standard

CODE OF PRACTICE FOR DESIGN AND CONSTRUCTION OF MACHINE FOUNDATIONS

PART IV FOUNDATIONS FOR ROTARY TYPE MACHINES OF LOW FREQUENCY

(First Revision)

Fifth Reprint JANUARY 1998

UDC 624.159.11:006.76:621.3.029.4-13

© *Copyright* 1980

BUREAU OF INDIAN STANDARDS
MANAK BHAVAN, 9 BAHADUR SHAH ZAFAR MARG
NEW DELHI 110002

July 1980

Indian Standard

CODE OF PRACTICE FOR
DESIGN AND CONSTRUCTION OF
MACHINE FOUNDATIONS

PART IV FOUNDATIONS FOR ROTARY TYPE
MACHINES OF LOW FREQUENCY

(First Revision)

Foundation Engineering Sectional Committee, BDC 43

Chairman

PROF DINESH MOHAN

*Representing*Central Building Research Institute (CSIR),
Roorkee*Members*

DR R. K. BHANDARI

Central Building Research Institute (CSIR),
Roorkee

SHRI I. G. CHACKO

Calcutta Port Trust, Calcutta

SHRI S. GUHA (*Alternate*)

SHRI K. N. DADINA

In personal capacity (*P-820, Block P, New Alipore, Calcutta*)

SHRI M. G. DANDAVATE

Concrete Association of India, Bombay

SHRI N. C. DUGGAL (*Alternate*)

SHRI R. K. DAS GUPTA

Simplex Concrete Piles (I) Pvt Ltd, Calcutta

SHRI H. GUHA BISWAS (*Alternate*)

SHRI A. G. DASTIDAR

In personal capacity (*5, Hungerford Court, 121 Hungerford Street, Calcutta*)

SHRI V. C. DESHPANDE

DIRECTOR (CSMRS)

Pressure Piling Co (India) Pvt Ltd, Bombay

DEPUTY DIRECTOR (CSMRS) (*Alternate*)

SHRI A. H. DIVANJI

Asia Foundation and Construction Pvt Ltd, Bombay

SHRI A. N. JANGLE (*Alternate*)

SHRI A. GHOSHAL

Braithwaite Burn & Jessop Construction Co Ltd,
CalcuttaSHRI N. E. A. RAGHAVAN (*Alternate*)

SHRI M. IYENGAR

Engineers India Ltd, New Delhi

DR R. K. M. BHANDARI (*Alternate*)

DR SHASHI K. GULHATI

Indian Institute of Technology, New Delhi

SHRI A. VARADARAJAN (*Alternate*)(*Continued on page 2*)

© Copyright 1980

BUREAU OF INDIAN STANDARDS

This publication is protected under the *Indian Copyright Act (XIV of 1957)* and reproduction in whole or in part by any means except with written permission of the publisher shall be deemed to be an infringement of copyright under the said Act.

(Continued from page 1)

<i>Members</i>	<i>Representing</i>
SHRI G. S. JAIN JOINT DIRECTOR RESEARCH (SM) (RDSO) JOINT DIRECTOR RESEARCH (B & S) RDSO (<i>Alternate</i>)	G. S. Jain & Associates, Roorkee Ministry of Railways
DR R. K. KATTI SHRI K. K. KHANNA SHRI SUNIL BERRY (<i>Alternate</i>) SHRI O. P. MALHOTRA	Indian Institute of Technology, Bombay National Buildings Organization, New Delhi
SHRI A. P. MATHUR SHRI V. B. MATHUR SHRI Y. V. NARASIMHA RAO	B & R Branch, Public Works Department, Govern- ment of Punjab, Chandigarh Central Warehousing Corporation, New Delhi Mckenzie's Limited, Bombay Bokaro Steel Plant (Steel Authority of India), Bokaro Steel City
BRIG OMBIR SINGH MAJ H. K. BHUTANI (<i>Alternate</i>) SHRI B. K. PANTHAKY SHRI V. M. MADGE (<i>Alternate</i>) SHRI S. R. KULKARNI SHRI S. ROY (<i>Alternate</i>) SHRI M. R. PUNJA PRESIDENT SECRETARY (<i>Alternate</i>) PROFESSOR (CIV ENGG) ASSISTANT PROFESSOR (CIV ENGG) (<i>Alternate</i>)	Engineer-in-Chief's Branch, Army Headquarters Hindustan Construction Co Ltd, Bombay M. N. Dastur & Company Pvt Ltd, Calcutta Cemmdia Company Ltd, Calcutta Indian Geotechnical Society, New Delhi College of Engineering, Guindy, Madras
SHRI A. A. RAJU DR GOPAL RANJAN DR V. V. S. RAO SHRI ARJUN RIJHSINGHANI SHRI O. P. SRIVASTAVA (<i>Alternate</i>) SHRI K. R. SAXENA	Steel Authority of India, New Delhi University of Roorkee, Roorkee Nagadi Consultants Pvt Ltd, New Delhi Cement Corporation of India, New Delhi Engineering Research Laboratories, Government of Andhra Pradesh
DR S. P. SHRIVASTAVA DR R. KAPUR (<i>Alternate</i>) SHRI N. SIVAGURU SHRI S. SEETHARAMAN (<i>Alternate</i>) SHRI T. N. SUBBA RAO SHRI S. A. REDDI (<i>Alternate</i>) SUPERINTENDING ENGINEER (DESIGN) EXECUTIVE ENGINEER (DESIGN V) (<i>Alternate</i>)	United Technical Consultants Pvt Ltd, New Delhi Roads Wing, Ministry of Shipping & Transport Gammon India Ltd, Bombay Central Public Works Department, New Delhi
SHRI M. D. TAMBEKAR SHRI D. AJITHA SIMHA, Director (Civ Engg)	Bombay Port Trust, Bombay Director General, ISI (<i>Ex-officio Member</i>)

Secretaries

SHRI G. RAMAN
Deputy Director (Civ Engg), ISI

●SHRI K. M. MATHUR
Deputy Director (Civ Engg), ISI

(Continued on page 21)

*Indian Standard*CODE OF PRACTICE FOR
DESIGN AND CONSTRUCTION OF
MACHINE FOUNDATIONSPART IV FOUNDATIONS FOR ROTARY TYPE
MACHINES OF LOW FREQUENCY*(First Revision)*

0. FOREWORD

0.1 This Indian Standard (Part IV) (First Revision) was adopted by the Indian Standards Institution on 5 September 1979, after the draft finalized by the Foundation Engineering Sectional Committee had been approved by the Civil Engineering Division Council.

0.2 The installations of rotary type machines of low frequency requires careful study of the foundation system taking into consideration the vibration characteristics. The construction of such foundations involves expenditure of considerable amount, materials and time. Substantial economy may be achieved if a proper investigation of the behaviour of the foundation system is made. This standard (Part IV) lays down the general principles with regard to foundations for rotary machines of low frequency (below 1 500 rev/min), for example, crushers, pumps, motor generators, compressors and rolling mill stands. The other parts of this standard published so far are the following:

- IS : 2974 (Part I) - 1969 Code of practice for design and construction of machine foundations: Part I Foundations for reciprocating type machines (*first revision*)
- IS : 2974 (Part II) - 1966 Code of practice for design and construction of machine foundations: Part II Foundations for impact type machines (drop and forge hammer foundations)
- IS : 2974 (Part III) - 1975 Code of practice for design and construction of machine foundations: Part III Foundations for rotary type machines (medium and high frequency) (*first revision*)
- IS : 2974 (Part V) - 1970 Code of practice for design and construction of machine foundations: Part V Foundations for impact type machines other than hammers (forging and stamping presses; pig breaker, elevator and hoist tower)

0.3 In the design of foundations for rotary machines, a proper team work between the different branches of engineering is essential. Coordinated efforts by the different branches would result in satisfactory performance, convenience of operation, economy and a good appearance of the complete unit.

0.4 This standard was first published in the year 1968. The revision has been prepared based on a number of comments received on this standard in the past 11 years.

0.5 In the formulation of this standard due weightage has been given to international co-ordination among the standards and practices prevailing in different countries in addition to relating it to the practices in the field in this country.

0.6 For the purpose of deciding whether a particular requirement of this standard is complied with, the final value, observed or calculated, expressing the result of a test or analysis, shall be rounded off in accordance with IS : 2-1960*. The number of significant places retained in the rounded off value should be the same as that of the specified value in this standard.

1. SCOPE

1.1 This standard (Part IV) deals with the design and construction of foundations, such as block foundations, framed foundations and other similar supported constructions of reinforced concrete for the installation of rotary machines of speeds up to 1 500 rev/min. Some typical machines of this type are crushing mills, pumps, motor generators, compressors and rolling mill stands.

Figures 1, 2 and 3 show typical foundations for a crushing mill (pulverizer unit), a primary air fan and an instrument air compressor, respectively.

2. TERMINOLOGY

2.1 For the purpose of this standard, the definitions given in IS : 2974 (Part I)-1969†, IS : 2974 (Part II)-1966‡, IS : 2974 (Part III)-1975§ and IS : 2810-1979||, shall apply.

*Rules for rounding off numerical values (revised).

†Code of practice for design and construction of machine foundations: Part I Foundations for reciprocating type machines (first revision).

‡Code of practice for design and construction of machine foundations: Part II Foundations for impact type machines (drop and forge hammer foundations).

§Code of practice for design and construction of machine foundations: Part III Foundations for rotary type machines (medium and high frequency) (first revision).

||Specification for glossary of terms and symbols relating to soils dynamics (first revision).

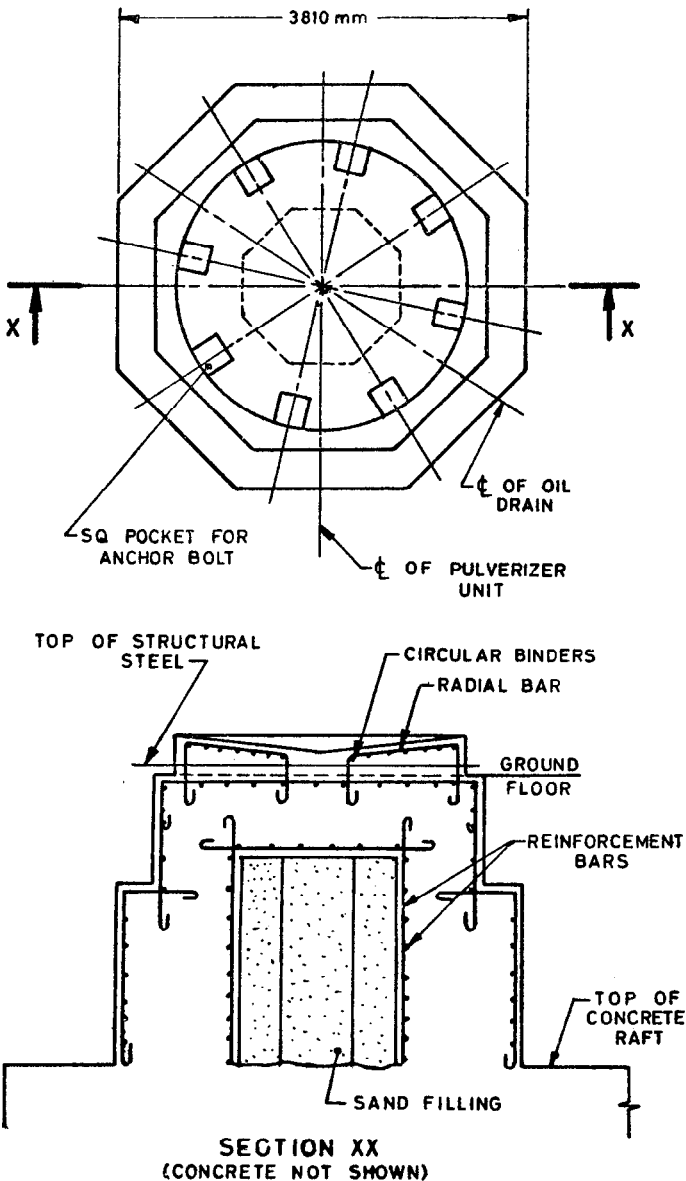

FIG. 1 TYPICAL FOUNDATION FOR CRUSHING MILL
(PULVERIZER UNIT)

☉ OF DISCHARGE OF PRIMARY
AIR FAN UNIT

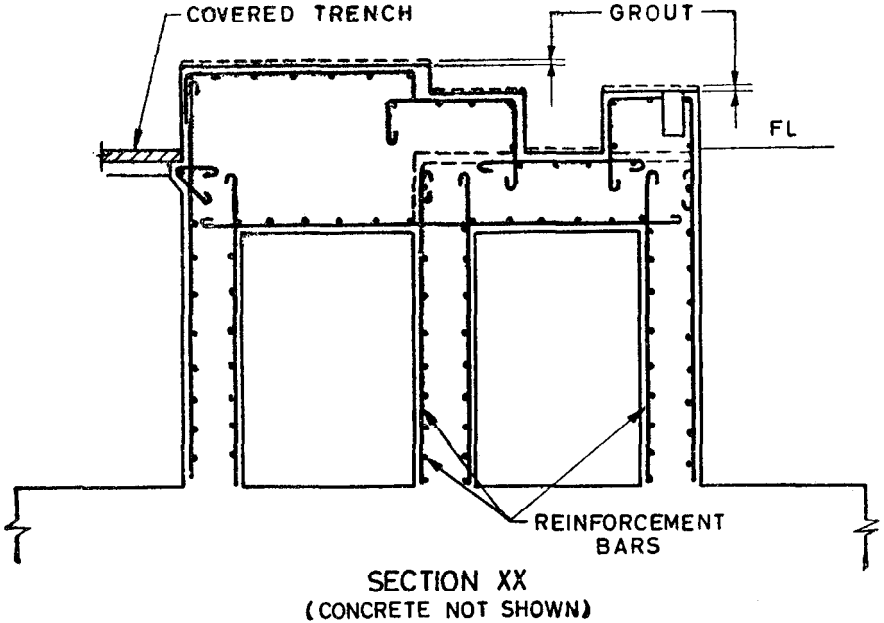
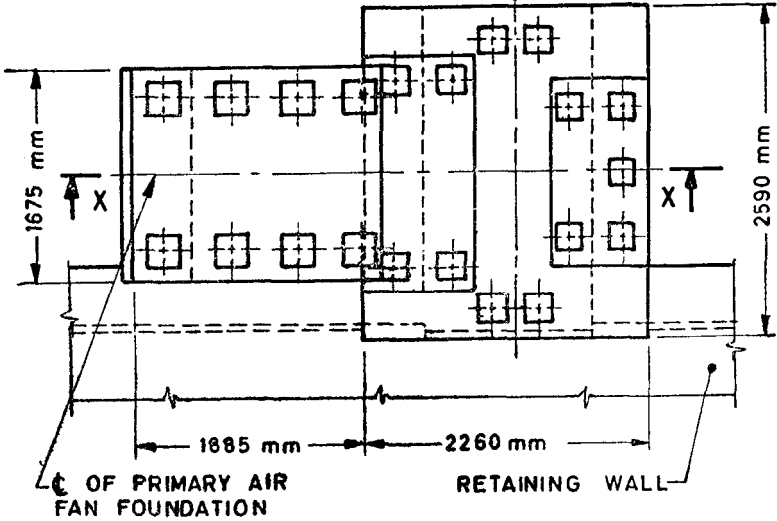

FIG. 2 TYPICAL FOUNDATION FOR PRIMARY AIR FAN

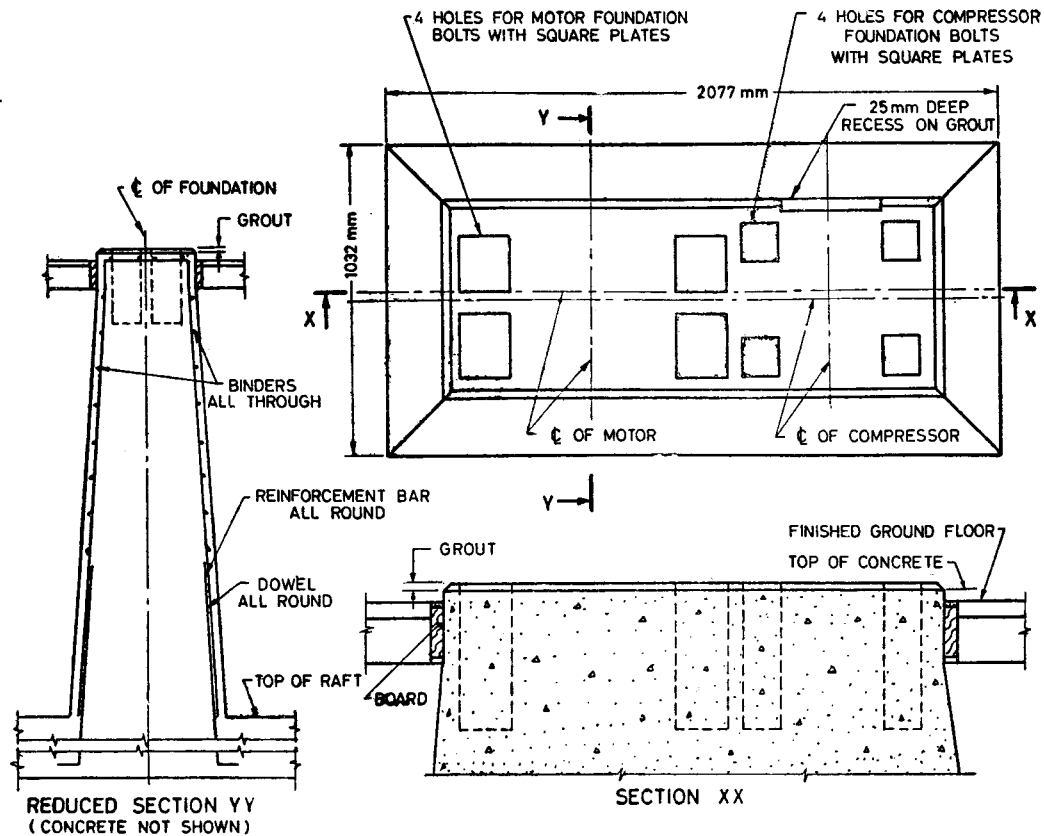

FIG. 3 TYPICAL FOUNDATION FOR INSTRUMENT AIR COMPRESSOR

3. NOTATIONS

3.1 Notations given in Appendix A shall apply.

4. NECESSARY DATA

4.1 The following information shall be obtained from the manufacturers of the machine for guidance in designing. Data required for some typical machines are listed below. For other machines, which will be more or less similar to one type or other, the designer should use his judgement.

a) *Crushing Mill:*

- 1) Outline drawing of the crushing mill with details of loading points;
- 2) Details of anchor bolts, channels and other embedments in foundations;
- 3) Mass of crusher parts;
- 4) Mass of motor drive;
- 5) Speed of main shaft; and
- 6) The unbalanced forces.

b) *Pumps:*

- 1) Mass of the pump;
- 2) Details of anchor bolts, channels and other embedments in foundations;
- 3) Frequency of pressure change in pump discharge;
- 4) Speed of pump;
- 5) Unbalanced forces; and
- 6) Number of impeller vanes.

c) *Motor Generators:*

- 1) Outline drawing of the machinery;
- 2) Mass of motor generator set, including separate masses for driving motor and generator;
- 3) Masses of the rotors for both the motor and the generator and mass of fly wheel;
- 4) Details of anchor bolts, channels and other embedments in foundations;
- 5) Operating speed; and
- 6) Short-circuiting force or moment.

d) *Rolling Mills:*

- 1) Mass of rolling mill stands;
- 2) Mass of the motor driving the rolling mill;
- 3) Separate masses of the rotor and stator;
- 4) Maximum torque on the shaft;
- 5) Loads occurring on assembly line; and
- 6) Details of anchor bolts, channels and other inserts.

4.1.1 In all cases, a detailed loading plan showing the point of application of all loads to be considered in foundation design shall be furnished by the manufacturer. A typical loading for a coal crusher mill plan is shown in Fig. 4. In addition to the above data, the capacity or rated output of each machine shall also be specified.

4.2 Subsurface Investigation

4.2.1 The site shall be subject to a careful and thorough soil exploration in such a manner that all relevant information pertaining to the proper design and construction of the foundation are available.

4.2.2 For satisfactory design and construction, the following subsoil data shall also be known:

- a) Soil profile and data generally up to a depth of thrice the width of the foundation measured from base of foundation or till hard strata is reached, whichever is less including soil characteristics in accordance with IS : 1892-1979*,
- b) Dynamic soil investigation to the extent necessary in accordance with IS : 5249-1977† for determining dynamic properties, and
- c) The relative positions of water table below ground level at different times of the year.

4.2.3 Where foundations of such machinery are required to be located close to a building or other foundation, care shall be taken to protect it from non-uniform stresses imposed by adjacent foundations. In view of this a minimum distance to any other foundation in the vicinity of the rotary machine foundation shall be ascertained.

5. DESIGN CRITERIA

5.1 Isolation

5.1.1 To avoid transmission of vibration to adjoining parts of buildings or other foundations, it is necessary to provide a suitable isolation between the equipment foundation and the adjoining structures. This may commonly

*Code of practice for subsurface investigation for foundation (*first revision*).

†Method of test for the determination of dynamic properties of soil (*first revision*).

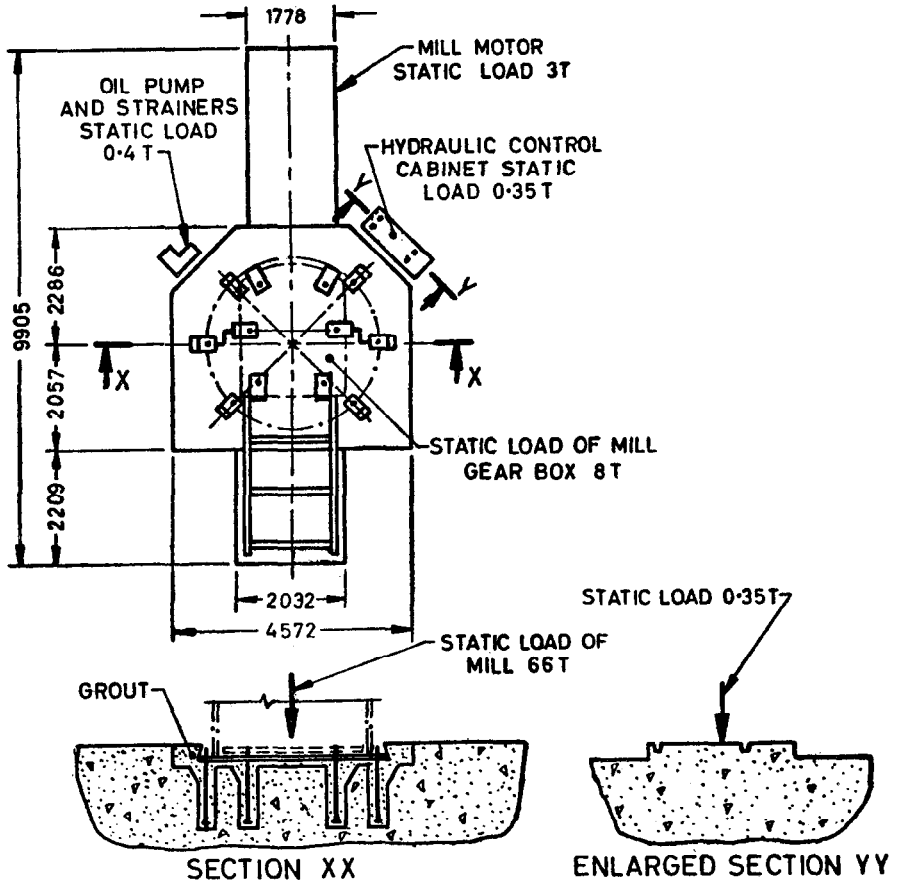

NOTE 1 — All loads indicated are static; suitable allowance to be made for live conditions.

NOTE 2 — 60 percent of all static loads of machines may be taken as weights of the rotating parts.

All dimensions in millimetres.

FIG. 4 TYPICAL LOADING PLAN FOR FOUNDATION OF COAL CRUSHER

be achieved by providing sand trench around the foundation block, the thickness and depth of which shall be determined for each individual case. As a rule, the equipment foundation shall not be allowed to serve as a support for other structures or for machineries not related to the particular equipment.

5.1.2 In case it becomes necessary to support unimportant parts of other structures on the machine foundation, measures shall be taken to make the

connection resilient by introducing gaskets made of rubber, cork, felt or other resilient material.

5.2 Design Considerations and Rigidity

5.2.1 Where a number of similar machines are to be installed side by side in a close spacing and soil conditions do not permit construction of independent foundation for each machine, then the foundations for all the similar machines may be combined by one common mat of sufficient thickness. The mat shall be enough so that deformations are minor as compared to the resultant amplitude of vibration.

5.2.2 To avoid distortion of the machine shaft due to differential settlement, all the external bearings of the shaft shall be accommodated on the same foundation.

5.2.3 The natural frequencies of the foundation are directly influenced by the side of foundation in terms of total mass and contact area. Therefore, the mass and the contact area shall be decided taking into consideration the vibration requirements. As a guide, the mass of the foundation should be at least 2.5 times the mass of the whole machine.

5.2.4 As far as possible, the foundations shall be so dimensioned that the resultant force due to the mass of the machine and the mass of the foundation passes through the centre of gravity of the base contact area.

5.2.5 Stress analysis of a foundation block may not be required because of the small magnitude of stresses imposed by static and dynamic external loads. In addition to the computation of amplitudes of transverse vibrations, it is necessary to avoid eccentricity in the foundation as far as possible and check the magnitude of the pressure imposed on soil under static and dynamic loads.

5.2.6 The requirements for frame foundations shall be in accordance with IS : 2974 (Part III)-1975*.

5.3 Frequency Distance — Natural frequency of the foundation system shall be such as will avoid resonance with the operating speed of the machine, and amplitudes of vibrations should be kept below the values given in 5.4. Foundations for low frequency machines shall preferably be so designed that natural frequencies are much higher than the operating frequency of the machine. The natural frequency of any foundation should not preferably within 20 percent of the operating speed of the machine.

5.4 Permissible Amplitudes

5.4.1 It is extremely difficult to establish a limit for the permissible value of amplitude of foundation vibrations on the basis of general principles.

*Code of practice for design and construction of machine foundations: Part III Foundations for rotary type machines (medium and high frequency) (*first revision*).

On the strength of data gained by experience so far, it is possible to state that if no resonance is to occur in adjoining structure, the amplitudes of vibrations of a foundation at the upper edge shall not exceed 0.20 mm in both directions. This amplitude is stated only as a guide to evaluate the adequacy of the foundation.

5.4.2 When several foundations for similar machines are erected on a common mat, the computation for vibration shall proceed assuming that each machine foundation is independent of others by breaking up the raft into sections corresponding to separate foundations. The design value for the permissible amplitude of vibrations may be increased by 30 percent.

5.5 Permissible Stresses

5.5.1 Concrete of M15 or higher shall be used for foundations. Concrete and steel stresses as specified in IS : 456-1978* shall be used by considering the dynamic loads separately in detailed design. The following dynamic elastic moduli of concrete may be used in design:

<i>Grade of Concrete</i>	<i>Dynamic Elastic Modulus, kgf/cm²</i>
M 15	250 000
M 20	300 000
M 25	340 000
M 30	370 000

5.5.2 *Soil*— The soil stress below the foundations under dead loads only shall not exceed 80 percent of the allowable bearing pressure for static loading determined in accordance with IS : 6403-1971†.

5.5.3 When seismic forces are considered, the allowable stress on the soil may be increased as specified in IS : 1893-1975‡.

6. PRINCIPLES OF DESIGN

6.1 **Dead Loads to be Considered for the Design of the Foundations**— The dead load shall include the following:

- a) Mass of foundation and other structure if supported on the foundation, and
- b) Mass of mechanical equipment including mass of rotating parts.

6.2 **Live Loads to be Considered for the Design of the Foundation and Vibration Analysis**— Consideration for some typical machines, namely crushing

*Code of practice for plain and reinforced concrete (*third revision*).

†Code of practice for determination of allowable bearing pressure on shallow foundations,

‡Criteria for earthquake resistant design of structures (*third revision*).

mills, pumps, motor generators and rolling mills are given in 6.2.1 to 6.2.4 as a guidance. Design principles of other machines will be similar to one or the other type and the designer should use his judgement in each case.

6.2.1 Crushing Mills — Crushing mills shall include the following types:

- a) Gyratory crusher (with steep and flat cone),
- b) Jaw crusher,
- c) Roll crusher (single roll and double roll),
- d) Hammer crusher,
- e) Ball mills, and
- f) Tube mills.

6.2.1.1 Loads — The following loads shall be considered:

- a) Constructional loads,
- b) The load due to machine itself on the element, multiplied by 5, and
- c) The generating force due to unbalanced mass forces.

1) *Gyratory crusher with steep cone* — The value of the generating force due to unbalanced mass forces may be determined by the formula:

$$R = (m_1 r_1 - m_2 r_2) \omega^2$$

$$P_x = R \sin \omega t$$

$$P_y = R \cos \omega t$$

2) *Gyratory crusher with flat cone and a crusher*

$$P = P_o \sin \omega t$$

P_o = may be taken from the table below:

Type of Crusher (1)	Size of Crusher (2)	N (3)	P_o (4)
	mm	rev/min	tonnes
Gyratory crusher with flat cone	$\phi 1\ 200$	270	Inertial forces are not to be considered
	$\phi 1\ 650$	240	
	$\phi 2\ 100$	220	
Jaw crusher	1 200 × 900	170	6.00
	1 500 × 1 200	135	9.00
	2 100 × 1 500	100	12.00

NOTE 1 — For crushers with dimensions as in table above, but having different speed N_1 .

$$P'_o = P_o \frac{(N_1)^2}{N}$$

NOTE 2 — For crushers of dimensions other than those mentioned in table above, P_0 is to be assumed through interpolation.

NOTE 3 — In gyratory crusher with steep cone, force P acts at the centre of the main shaft, while in crusher with flat cone, it acts at the stationary point. This force is to be taken into consideration in the direction of minimum dimension of the foundation. In jaw crusher, P acts at the main shaft axis level in the direction of motion of the crusher.

- 3) *Roll crusher* — The value given by the manufacturer of the machine should be taken.
- 4) *Hammer crusher* — The generating force is to be calculated for three different types of unbalancing:
 - i) Maximum unbalanced force of rotor caused by considerable wear and tear of hammer (assuming $e = 1 \text{ mm}$)

$$R = m_r e \omega^2,$$
 - ii) Unbalanced force at normal balancing of machine according to manufacturer's specifications — 4-fold value to be considered for design, and
 - iii) Unbalanced force at catastrophic breakage of one hammer.

6.2.1.2 Dynamic analysis — The dynamic computation of the foundation for gyratory crusher, jaw crusher and roll crusher in principle should be in accordance with the provisions of IS : 2974 (Part I)-1969*. However, foundation for hammer crusher and tube mills is analysed based on the provisions of IS : 2974 (Part III)-1975†.

- a) *Hammer crushers* — Permissible amplitudes of displacement for hammer crushers and eccentricity for which foundations should be developed should normally be given by the machine suppliers. In the absence of these data, the following criteria may be assumed for design.

Permissible Amplitude of Displacement:

- 1) 0.3 mm for machines with operating frequency up to 300 cycles/min, and
- 2) 0.1 mm for machines with operating frequency above 300 cycles/min.

Eccentricity:

Regarding the calculation of unbalanced forces on account of eccentricity due to wear and tear, etc, the following principle may be followed :

- i) One millimetre eccentricity to be assumed for non-reversible hammer crusher of impact type.

*Code of practice for design and construction of machine foundations : Part I Foundations for reciprocating type machines (*first revision*).

†Code of practice for design and construction of machine foundations : Part III Foundations for rotary type machines (medium and high frequency) (*first revision*).

- ii) Two millimetres eccentricity to be assumed for reversible hammer crushers of impact type as well as attrition type.

The above eccentricities form the basis for checking structural safety of the foundation as well as for limiting the amplitudes within permissible limits as mentioned above.

b) *Tube Mills*

- 1) For the design of foundations for tube mills no dynamic analysis is necessary. It would be adequate to determine the soil stresses on the basis of the following loading:

- i) Dead mass of the foundation;
- ii) The mass of the machinery; and
- iii) Horizontal component of the centrifugal force normal to the axis of the drum (P_n), which may be evaluated as below:

In mills provided with a short drum, 10 percent of the mass of the mill (excluding the ball charge and the materials to be ground); and for mills provided with a long drum, it may be taken as 20 percent of the mass as defined above.

It would be presumed that the mass of the mill is uniformly divided over the two supports of the drum. For the purpose of computation of centrifugal forces short drums and long drums will be classified as follows:

Drums whose lengths do not exceed twice the diameters will be termed as short drums, whereas drums with lengths exceeding twice the diameters will be termed as long drums.

6.2.2 *Pumps*

6.2.2.1 *Loads* — The following loads shall be considered:

- a) Constructional loads, and
- b) Total mass of pump multiplied by 3.

6.2.2.2 *Dynamic analysis* — Insufficient clearance between the impeller and the casing tends to increase the pressure surges, and the encasing wave propagates through the water to the casing and to the foundation. The frequency of this type of vibration is given below:

$$f = \frac{Nn}{60}$$

6.2.3 *Motor Generators and Motor Drives*

6.2.3.1 *Loads* — The following loads shall be considered:

- a) Constructional loads;
- b) The loads due to the machine itself multiplied by a dynamic factor of 2; and

- c) *Torque load* — The torque acting on the foundation of the motor generator set may be obtained from the following equation:

$$M = \frac{2\pi}{60} I \frac{dN}{dt}$$

dN/dt , vary in practice from 2.8 to 10.4 and would be specified by the manufacturers.

M should be multiplied by a dynamic factor of 2.

6.2.3.2 *Dynamic analysis*

- a) Dynamic response check of the block foundation shall be carried out as per IS : 2974 (Part I)-1969*, and
- b) Permissible amplitudes of vibration of displacement shall be as follows:

For 750 to 1 500 rev/min — 0.06 to 0.04 mm

For less than 750 rev/min — 0.08 to 0.12 mm.

NOTE — The lower permissible amplitudes are recommended.

6.2.4 *Rolling Mills* — When designing rolling mills, the following elements shall be taken into consideration in the dynamic analysis:

- a) Driving motor (see 6.2.4.1),
- b) Motor generator set (see 6.2.3), and
- c) Roller stand and gear box (see 6.2.4.2).

6.2.4.1 *Driving motor* — Details are given below:

- a) It usually has a block foundation to which it is rigidly attached. Consequently, the system may be considered as a rigid body supported by the elastic soil;
- b) The torque of the motor will tend to rotate the foundation about an axis in the plane of the foundation and perpendicular to the plane of the torque through an angle ϕ . Therefore, the stresses on the soil over the contact area will vary and the maximum stress is :

$$\sigma_{\max} = \frac{Q}{F} + C \phi h \phi \text{ Max}$$

The value $\phi \text{ Max}$ may be found by any acceptable practice; and

- c) The computations for determining the forced vibrations and the permissible amplitudes of displacement are the same as for motor generators in 6.2.3.

6.2.4.2 *Roller stand and gear box*

a) *General principles:*

- 1) The purpose of the roller stand is to support the bearing of the rollers, and the forces arising during rolling are transmitted

*Code of practice for design and construction of machine foundations : Part I Foundations for reciprocating type machines (first revision).

by it to the foundation. The gear box comprises of the gears driving the rollers.

- 2) In the gear box, there will be torque of the same order of magnitude as those on the shaft of the driving motor. No external load will be transmitted through the roller stand to the foundation since the forces occurring during rolling are only on the roller stand. When the gear box and the roller stand are provided with separate foundations, the calculations for the gear box shall be carried out in the same way as for the driving motor.
- 3) If the roller stand, the gear box and the driving motor are supported on a common foundation, the computations of the foundation and of the soil stresses shall be carried out in the following way:

The foundation shall carry the total mass of the machinery and shall also be subjected to a torque of opposite direction to that acting on the motor shaft. When computing the soil stresses, the sum of the external moments acting on the foundation will be equal to 0; therefore, only the load of the machinery and the mass of the foundation need be taken into consideration.

- b) *Design loads* — For the analysis of stresses within the foundation for the determination of pressure on the base, the following shall be considered:

- 1) *Loads* — The following loads shall be considered:

- i) Mass of the rolling mill equipment;
- ii) Mass of the driving roll motor;
- iii) Maximum disconnecting moment at the motor shaft;
- iv) Horizontal force transmitted to the footings under manipulations and tilting devices; and
- v) Erection loads.

- 2) Static computations of the foundation may be limited to the following:

- i) Stress analysis of separate units of the foundation, such as units weakened by openings, cantilevers and others;
- ii) Computation of local stresses under supporting slabs;
- iii) Analysis of stress within the foundation; and
- iv) Computation of pressure transmitted to the soil.

- c) *Dynamic analysis* — The foundation is considered to be a girder of varying stiffness resting on an elastic base. For dynamic loads listed in 6.2.4.2 (b) (1) (i) and 6.2.4.2 (b) (1) (ii), a value of the

dynamic coefficient equal to 2 should be used in the calculations of the mass of the roller mill and of the driving roll motor. For dynamic loads listed in 6.2.4.2 (b) (1) (iii) and 6.2.4.2 (b) (1) (iv), the actual values should be taken without introducing a dynamic coefficient. The foundations subjected to horizontal impacts should be designed for the double value of the maximum horizontal force.

7. CONSTRUCTION CRITERIA

7.1 The concrete used shall be controlled concrete conforming to design requirements. The grade of concrete should generally be M 15 to M 20 for block foundation and M 20 for formed foundation. The concrete shall be designed and placed in accordance with IS : 456-1978*.

7.2 The concrete used shall be of plastic consistency without excessive water. A slump of 50 to 80 mm is allowable. The water cement ratio shall not exceed 0.45. The same consistency shall be maintained throughout the concreting of foundation.

7.3 Continuous concreting shall be done as far as possible for the entire block, leaving provisions for grouting (see 7.12).

7.4 In the process of machine assembly, prior to pouring cement grout under the machine bed plate and in pockets for anchor bolts, the adjoining foundation surface shall be cleaned well. This surface, except the pockets, shall be made rough so as to secure good bond with the fresh cement. Cement grout with non-shrinkage additive or suitable non-shrinking cement grout shall be used where structurally required. Details of grouting shall be as given in Appendix E of IS : 2974 (Part III)-1975†.

7.5 All units of foundation shall be provided with top and bottom two-way reinforcements. Reinforcement shall be provided along the surface only in case of block foundation.

7.6 The amount of reinforcement in each foundation element unit shall not be less than 50 kg/m³ of concrete. Typical arrangements of reinforcements are shown in Fig. 1, 2 and 3.

7.7 Stirrups suitably spaced shall be provided to tie together the main longitudinal bars.

7.8 The minimum diameter of the mild steel bars shall be 12 mm and the maximum spacing shall be 200 mm in order to take care of shrinkage in concrete.

*Code of practice for plain and reinforced concrete (*third revision*).

†Code of practice for design and construction of machine foundations: Part III Foundations for rotary type machines (medium and high frequency) (*first revision*).

7.9 The concrete cover for protection of reinforcement shall be 75 mm at the bottom, 50 mm on the sides and 40 mm at the top.

7.10 The finished surface of the foundation shall be properly levelled and checked before installing the machine.

7.11 For other details in case of frame foundations, provisions of IS : 2974 (Part III) - 1975* shall apply.

7.12 If construction joint is unavoidable, the plans of the joint shall be horizontal and measures shall be taken to provide a proper joint. Reinforcement shall be continuous and before placing the new layer of concrete the previously laid surface should be roughened, thoroughly cleaned and washed by a jet of water and then covered by a layer of rich 1 : 2 cement grout 20 mm thick. Concrete shall be placed not later than 2 hours after the grout is laid.

APPENDIX A

(Clause 3.1)

NOTATIONS

<i>Symbol</i>	<i>Description</i>	<i>Unit</i>
R	Unbalanced generating force	t
m_1	Total mass of main shaft and crushing cone attached to it (in crushing mills)	t s ² /m
m_2	Mass of cam shaft and units rigidly connected with it (gears, counterweights and others)	t s ² /m
m_r	mass of rotor	t s ² /m
r_1	Distance between crusher axis and centre of gravity of eccentric shaft	m
r_2	Distance between the other axis of the crusher and centre of gravity of eccentric shaft	m
P	Unbalanced generating force	t
P_0	Unbalanced generating force at speed N	t
P'_0	Unbalanced generating force at speed N_1	t
P_x	Unbalanced inertia force along x axis	t
P_y	Unbalanced inertia force along y axis	t
ω	Angular frequency of the cam shaft	s ⁻¹
t	Time	s

*Code of practice for design and construction of machine foundations : Part III Foundations for rotary type machines (medium and high frequency) (*first revision*).

IS : 2974 (Part IV) - 1979

<i>Symbol</i>	<i>Description</i>	<i>Unit</i>
e	Eccentricity	mm
f	Frequency of the pressure changes in the pump discharge	c/s
N or N_1	Speed	rev/min
n	Number of impeller vanes	—
M	Torque moment	t m
I	Mass moment of inertia of the rotating mass	t m s ²
ν	Dynamic factor	
ϕ	Angle of rotation of the foundation	radian
σ_{mr}	Maximum stress in soil	t/m ²
Q	Weight of concrete foundation and of the machinery	t
F	Surface area of the foundation in contact with soil	m ²
$C\phi$	Coefficient of elastic non-uniform compression of soil	kg/m ³
h	Half dimensions of the foundation in the plane of the torque	m
$\frac{dN}{dt}$	Change in speed of the motor generating set	rev/min

(Continued from page 2)

Foundations Subject to Dynamic Loads Subcommittee, BDC 43 : 1

Convener

SHRI K. N. DADINA

*Representing*In personal capacity (P-820, Block P. New Alipore,
Calcutta)*Members*SHRI N. K. BASU
DIRECTOR (TCD)Cementation Company Ltd, Calcutta
Central Electricity Authority, New DelhiDEPUTY DIRECTOR (TCD) (*Alternate*)

SHRI A. D. GUPTA

Fertilizer Corporation of India Ltd, Dhanbad

SHRI D. H. PATEL (*Alternate*)

SHRI M. IYENGAR

Engineers India Ltd, New Delhi

SHRI J. K. BAGCHI (*Alternate*)

DR A. K. MUKHERJEE

Development Consultants Ltd, Calcutta

SHRI S. K. RAY (*Alternate*)

SHRI M. V. PANDIT

Bharat Heavy Electricals Ltd, Bhopal

SHRI S. K. JAIN (*Alternate*)

SHRI R. PURI

University of Roorkee, Roorkee

DR V. V. S. RAO

Nagadi Consultants Pvt Ltd, New Delhi

SHRI S. K. SANYAL

Metallurgical & Engineering Consultants (India)
Ltd, Ranchi

DR P. SRINIVASULU

Structural Engineering Research Centre (CSIR),
RoorkeeSHRI N. LAKSHIMANAN (*Alternate*)

BUREAU OF INDIAN STANDARDS

Headquarters:

Manak Bhavan, 9 Bahadur Shah Zafar Marg, NEW DELHI 110002

Telephones: 323 0131, 323 3375, 323 9402

Fax : 91 11 3234062, 91 11 3239399, 91 11 3239382

Telegrams : Manaksanstha
(Common to all Offices)

Central Laboratory :

Plot No. 20/9, Site IV, Sahibabad Industrial Area, Sahibabad 201010

Telephone

8-77 00 32

Regional Offices:

Central : Manak Bhavan, 9 Bahadur Shah Zafar Marg, NEW DELHI 110002 323 76 17

*Eastern : 1/14 CIT Scheme VII M, V.I.P. Road, Maniktola, CALCUTTA 700054 337 86 62

Northern : SCO 335-336, Sector 34-A, CHANDIGARH 160022 60 38 43

Southern : C.I.T. Campus, IV Cross Road, CHENNAI 600113 235 23 15

†Western : Manakalaya, E9, Behind Marol Telephone Exchange, Andheri (East),
MUMBAI 400093 832 92 95

Branch Offices::

'Pushpak', Nurmohamed Shaikh Marg, Khanpur, AHMEDABAD 380001 550 13 48

‡Peenya Industrial Area, 1st Stage, Bangalore-Tumkur Road,
BANGALORE 560058 839 49 55

Gangotri Complex, 5th Floor, Bhadbhada Road, T.T. Nagar, BHOPAL 462003 55 40 21

Plot No. 62-63, Unit VI, Ganga Nagar, BHUBANESHWAR 751001 40 36 27

Kalaikathir Buildings, 670 Avinashi Road, COIMBATORE 641037 21 01 41

Plot No. 43, Sector 16 A, Mathura Road, FARIDABAD 121001 8-28 88 01

Savitri Complex, 116 G.T. Road, GHAZIABAD 201001 8-71 19 96

53/5 Ward No.29, R.G. Barua Road, 5th By-lane, GUWAHATI 781003 54 11 37

5-8-56C, L.N. Gupta Marg, Nampally Station Road, HYDERABAD 500001 20 10 83

E-52, Chitaranjan Marg, C- Scheme, JAIPUR 302001 37 29 25

117/418 B, Sarvodaya Nagar, KANPUR 208005 21 68 76

Seth Bhawan, 2nd Floor, Behind Leela Cinema, Naval Kishore Road,
LUCKNOW 226001 23 89 23

NIT Building, Second Floor, Gokulpat Market, NAGPUR 440010 52 51 71

Patliputra Industrial Estate, PATNA 800013 26 23 05

Institution of Engineers (India) Building 1332 Shivaji Nagar, PUNE 411005 32 36 35

T.C. No. 14/1421, University P. O. Palayam, THIRUVANANTHAPURAM 695034 6 21 17

*Sales Office is at 5 Chowringhee Approach, P.O. Princep Street,
CALCUTTA 700072 27 10 85

†Sales Office is at Novelty Chambers, Grant Road, MUMBAI 400007 309 65 28

‡Sales Office is at 'F' Block, Unity Building, Narashimaraaja Square,
BANGALORE 560002 222 39 71

TO

**IS : 2974 (Part IV)-1979 | CODE OF PRACTICE
FOR DESIGN AND CONSTRUCTION OF
MACHINE FOUNDATIONS**

**PART IV FOUNDATIONS FOR ROTARY TYPE MACHINES
OF LOW FREQUENCY**

(First Revision)

Alterations

[Page 3, clause 0.2, lines 14 to 16, reference to IS : 2974 (Part II)-1966) — Substitute the following for the existing matter:

‘ IS : 2974 (Part II)-1980 Code of practice for design and construction of machine foundations : Part II Foundations for impact type machines (drop and forge hammer foundations) (*first revision*). ’

(Page 4, clause 2.1, line 2) — Substitute ‘ IS : 2974 (Part II)-1980† ’ for ‘ IS : 2974 (Part II)-1966‡ ’.

(Page 4, foot-note with ‘ ‡ ’ mark) — Substitute the following for the existing foot-note:

‘ †Code of practice for design and construction of machine foundations: Part II Foundations for impact type machines (drop and forge hammer foundations (*first revision*). ’

(Page 12, clause 5.5.2, line 3) — Substitute ‘ IS : 6403-1981† ’ for IS : 6403-1971‡ ’.

(Page 12, foot-note with ‘ † ’ mark) — Substitute the following for the existing foot-note:

‘ †Code of practice for determination of bearing capacity of shallow foundations (*first revision*). ’

(Page 18, clause 7.6) — Substitute the following for the existing clause:

‘ 7.6 The amount of minimum reinforcement for block foundation shall be 25 kg/m³ of concrete. The amount of minimum reinforcement for frame foundations shall be 40 kg/m³ of concrete for base slab, 70 kg/m³ of concrete for columns and 90 kg/m³ of concrete for top table. The typical arrangements for the reinforcement for three types of foundation are shown in Fig. 1 to 3. ’