

IS : 2974 (Part II) - 1980

(Reaffirmed 1993)

Indian Standard

CODE OF PRACTICE FOR
DESIGN AND CONSTRUCTION OF
MACHINE FOUNDATIONS

PART II FOUNDATIONS FOR IMPACT TYPE MACHINES
(HAMMER FOUNDATIONS)

(First Revision)

Third Reprint JANUARY 1998

UDC 624.159.11:621.974.2:006.76

© Copyright 1981

BUREAU OF INDIAN STANDARDS
MANAK BHAVAN, 9 BAHADUR SHAH ZAFAR MARG
NEW DELHI 110002

*Indian Standard*CODE OF PRACTICE FOR
DESIGN AND CONSTRUCTION OF
MACHINE FOUNDATIONSPART II FOUNDATIONS FOR IMPACT TYPE MACHINES
(HAMMER FOUNDATIONS)*(First Revision)*

Foundation Engineering Sectional Committee, BDC 43

Chairman

PROF DINESH MOHAN

*Representing*Central Building Research Institute (CSIR),
Roorkee*Members*

DR R. K. BHANDARI

Central Building Research Institute (CSIR),
Roorkee

SHRI I. G. CHACKO

Calcutta Port Trust, Calcutta

SHRI S. GUHA (*Alternate*)

SHRI K. N. DADINA

In personal capacity (*P-820, Block P, New Alipore, Calcutta*)

SHRI M. G. DANDAVATE

Concrete Association of India, Bombay

SHRI N. C. DUGGAL (*Alternate*)

SHRI R. K. DAS GUPTA

Simplex Concrete Piles (I) Pvt Ltd, Calcutta

SHRI H. GUHA BISWAS (*Alternate*)

SHRI A. G. DASTIDAR

In personal capacity (*5, Hungerford Court, 121 Hungerford Street, Calcutta*)

SHRI V. C. DESHPANDE

Pressure Piling Co (India) Pvt Ltd, Bombay

DIRECTOR (CSMRS)

Central Water Commission, New Delhi

DEPUTY DIRECTOR (CSMRS) (*Alternate*)

SHRI A. H. DIVANJJI

Asia Foundation & Construction Pvt Ltd,
BombaySHRI A. N. JANGLE (*Alternate*)

SHRI A. GHOSHAL

Braithwaite Burn & Jessop Construction Co Ltd,
CalcuttaSHRI N. E. A. RAGHAVAN (*Alternate*)

DR GOPAL RANJAN

University of Roorkee, Roorkee

DR SHASHI K. GULHATI

Indian Institute of Technology, New Delhi

SHRI A. VARADARAJAN (*Alternate*)*(Continued on page 2)*

© Copyright 1981

BUREAU OF INDIAN STANDARDS

This publication is protected under the *Indian Copyright Act (XIV of 1957)* and reproduction in whole or in part by any means except with written permission of the publisher shall be deemed to be an infringement of copyright under the said Act.

IS : 2974 (Part II) - 1980

(Continued from page 1)

| <i>Members</i> | <i>Representing</i> |
|---|--|
| SHRI M. IYENGAR | Engineers India Ltd, New Delhi |
| DR R. K. M. BHANDARI (<i>Alternate</i>) | |
| SHRI G. R. S. JAIN | G. S. Jain & Associates, Roorkee |
| JOINT DIRECTOR RESEARCH (SM) | Ministry of Railways |
| (RDSO) | |
| JOINT DIRECTOR RESEARCH (B&S), | |
| RDSO (<i>Alternate</i>) | |
| DR R. K. KATTI | Indian Institute of Technology, Bombay |
| SHRI K. K. KHANNA | National Buildings Organization, New Delhi |
| SHRI SUNIL BERRY (<i>Alternate</i>) | |
| SHRI S. R. KULKARNI | M. N. Dastur & Company Pvt Ltd, Calcutta |
| SHRI S. ROY (<i>Alternate</i>) | |
| SHRI O. P. MALHOTRA | Building & Roads Branch, Public Works Department, Government of Punjab, Chandigarh |
| | Central Warehousing Corporation, New Delhi |
| SHRI A. P. MATHUR | Mckenzie Limited, Bombay |
| SHRI V. B. MATHUR | Bokaro Steel Plant (Steel Authority of India), Bokaro Steel City |
| SHRI Y. V. NARASIMHA RAO | Engineer-in-Chief's Branch, Army Headquarters |
| BRIG OMBIR SINGH | |
| MAJ H. K. BHUTANI (<i>Alternate</i>) | Hindustan Construction Co Ltd, Bombay |
| SHRI B. K. PANTHAKY | |
| SHRI V. M. MADGE (<i>Alternate</i>) | Indian Geotechnical Society, New Delhi |
| PRESIDENT | |
| SECRETARY (<i>Alternate</i>) | |
| PROFESSOR (CIVIL ENGG) | College of Engineering, Guindy, Madras |
| ASSISTANT PROFESSOR (CIVIL ENGG) (<i>Alternate</i>) | |
| SHRI M. R. PUNJA | Cementation Co Ltd, Bombay |
| SHRI A. A. RAJU | Steel Authority of India, New Delhi |
| DR V. V. S. RAO | Nagadi Consultants Pvt Ltd, New Delhi |
| SHRI ARJUN RIJHSINGHANI | Cement Corporation of India, New Delhi |
| SHRI O. S. SRIVASTAVA (<i>Alternate</i>) | |
| SHRI K. R. SAXENA | Engineering Research Laboratories, Government of Andhra Pradesh, Hyderabad |
| DR S. P. SRIVASTAVA | United Technical Consultants Pvt Ltd, New Delhi |
| DR R. KAPUR (<i>Alternate</i>) | |
| SHRI N. SIVAGURU | Roads Wing, Ministry of Shipping & Transport |
| SHRI S. SEETHARAMAN (<i>Alternate</i>) | |
| SHRI T. N. SUBBA RAO | Gammon India Ltd, Bombay |
| SHRI S. A. REDDI (<i>Alternate</i>) | |
| SUPERINTENDING ENGINEER (DESIGN) | Central Public Works Department, New Delhi |
| EXECUTIVE ENGINEER (DESIGN V) (<i>Alternate</i>) | |
| SHRI M. D. TAMBEKAR | Bombay Port Trust, Bombay |
| SHRI D. AJITHA SETHA, | Director General, BIS (<i>Ex-officio Member</i>) |
| Director (Civ Engg) | |

Secretary

SHRI K. M. MATHUR
Deputy Director (Civ Engg), BIS

(Continued on page 15)

Indian Standard

CODE OF PRACTICE FOR DESIGN AND CONSTRUCTION OF MACHINE FOUNDATIONS

PART II FOUNDATIONS FOR IMPACT TYPE MACHINES (HAMMER FOUNDATIONS)

(First Revision)

0. FOREWORD

0.1 This Indian Standard (Part II) (First Revision) was adopted by the Indian Standards Institution on 31 July 1980, after the draft finalized by the Foundation Engineering Sectional Committee had been approved by the Civil Engineering Division Council.

0.2 The installation of heavy machinery involves careful design of their foundations taking into consideration the impact and vibration characteristics of the load and the condition of the soil on which the foundation rests. While many of the special features relating to the design and construction of such machine foundations will have to be as advised by the manufacturers of these machines, still most of the details will have to be according to general principles of design. This part (Part II) of the standard lays down the general principles with regard to foundations for impact type machines (hammer foundations). This standard was first published in 1966. This revision has been prepared based on experience gained in the implementation of this standard.

0.3 This standard on machine foundations is published in five parts. Other parts are:

Part I Foundations for reciprocating type machines.

Part III Foundations for rotary type machines (medium and high frequency).

Part IV Foundations for rotary type machines of low frequency.

Part V Foundations for impact type machines other than hammer (forging and stamping press, pig breaker, elevator and hoist towers).

0.4 For the purpose of deciding whether a particular requirement of this standard is complied with, the final value, observed or calculated, expressing the result of a test, shall be rounded off in accordance with IS : 2-1960*.

*Rules for rounding off numerical values (*revised*).

The number of significant places retained in the rounded off value should be the same as that of the specified value in this standard.

1. SCOPE

1.1 This standard (Part II) covers design and construction of hammer foundation subject to stray and repeated impacts and where the ratio of mass of anvil to foundation is high.

2. TERMINOLOGY

2.0 For the purpose of this standard, the following and the relevant definitions in IS : 2974 (Part I)-1964*, shall apply.

2.1 **Anvil** — A base-block for a hammer on which material is forged into shape by repeated striking of the tup (see Fig. 1).

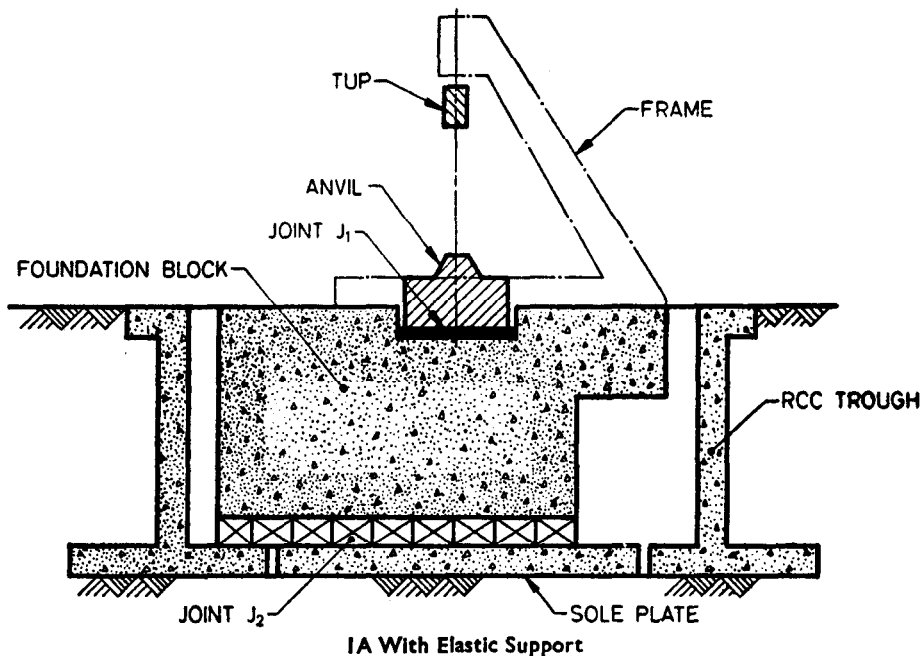

FIG. 1 DIFFERENT TYPES OF FOUNDATION SUPPORT—Contd

2.2 **Capacity of Hammer** — It is expressed as the mass of the falling tup.

*Code of practice for design and construction of machine foundations: Part I Foundations for reciprocating type machines (first revision).

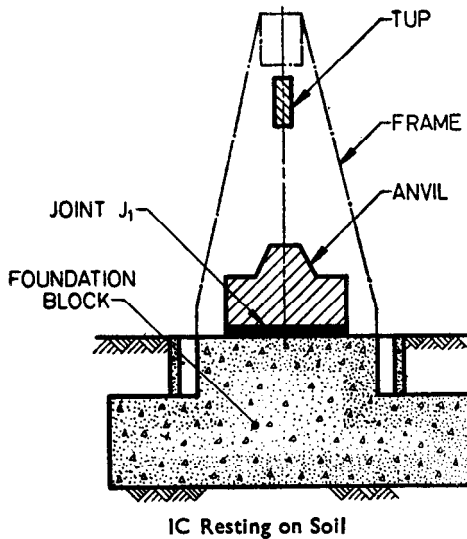
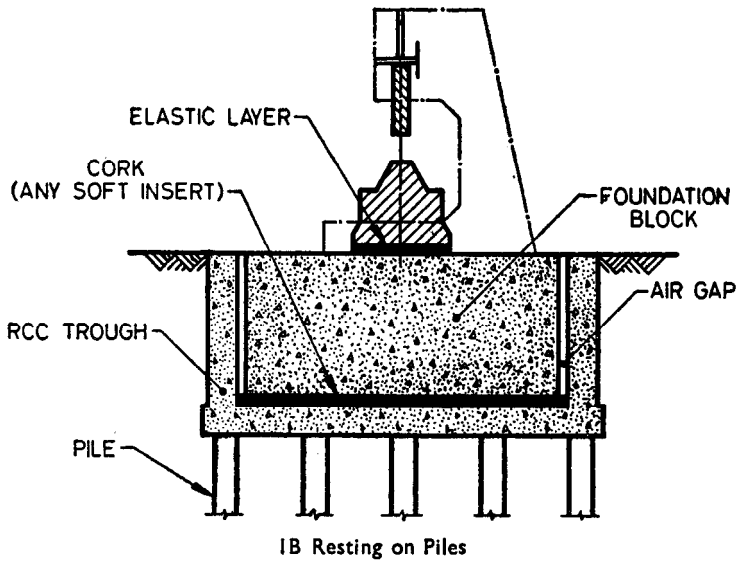

FIG. 1 DIFFERENT TYPES OF FOUNDATION SUPPORT

2.3 Foundation Block — A mass of reinforced concrete on which the anvil rests (see Fig. 1).

2.4 Foundation Support — A support for resting the foundation block. The block may rest directly on ground or on a resilient mounting, such as timber sleepers, springs, cork layer, etc. The block may also be supported on pile foundations.

2.5 Impact Force (F) — The force produced when the falling tup strikes the material being forged on the anvil.

2.6 Coefficient of Restitution (k) — A coefficient used to determine the velocity of the anvil and the foundation block after the tup strikes. This coefficient is governed by the condition $0 < k < 1$ and its average value for design purposes may be taken up to 0.6. However, in specific known cases this value may be reduced.

2.7 Protective Cushioning Layer (Elastic Pad) — An elastic cushioning of suitable material and thickness provided between the anvil and the foundation block in order to prevent bouncing of anvil and creation of large impact stresses and consequent damage to the top surface of the concrete in the foundation block.

2.8 Tup — A weighted block which strikes the material being forged on the anvil (*see* Fig. 1).

3. NECESSARY DATA

3.1 Hammer Details

- a) Total mass of hammer, that is, mass of frame and falling parts;
- b) Mass of falling parts, that is, mass of tup and top die;
- c) Mass of anvil (in case guide frame of the hammer is attached to the anvil, the mass of the frame should be added);
- d) Energy of impact;
- e) Number of blows per minute (this may vary depending on full stroke and short stroke);
- f) Base dimensions of the anvil;
- g) Manufacturer's drawing showing general cross section, plan, elevation of anvil, frame base, anvil base, etc, including details of anchor bolts; and
- h) Coefficient of impact of anvil in extreme case for die to die blow.

3.2 Details of the Cushion Pad Between Anvil and Block

- a) Material,
- b) Elastic modulus,
- c) Maximum allowable deformation, and
- d) Allowable stress intensity.

3.3 Details of Cushioning Between Foundation Block and Soil, If Provided

- a) If resilient pad is used:
 - 1) Material,
 - 2) Elastic modulus,
 - 3) Maximum allowable deformation, and
 - 4) Allowable stress intensity.
- b) If springs and dampers are used:
 - 1) Maximum allowable spring deflections for normal working as well as for extreme conditions and also for static loads as well as for dynamic loads,
 - 2) Details of springs, and
 - 3) Details of dampers.

3.4 Soil Data

3.4.1 The sub-soil properties shall be determined according to IS : 1892-1979*.

3.4.2 The dynamic elastic properties of the soil shall be ascertained according to IS : 5249-1977†.

3.5 Information about the location of the hammer in the shop with respect to adjacent foundations; the dimensions, elevations and depth of these foundations as well as their tolerable amplitudes, shall be provided.

4. DESIGN CRITERIA

4.1 General Considerations — The hammer foundation shall satisfy the following requirements:

- a) The design of the entire foundation system shall be such that the centres of gravity of the anvil and of the foundation block, as well as the resultants of the forces in the elastic pad and the foundation support, act as far as practicable so as to coincide with the line of fall of the hammer tup. While determining the centre of gravity of the foundation block the weight of the frame and of the tup shall also be considered.
- b) The foundation shall be so designed that the induced vibrations in the structures nearby are within the safe limits fixed for them.
- c) In case of hammers having continuous impacts, the design shall be such that the natural frequency of the foundation system will not be a whole number multiple of the operating frequency of impact. A natural frequency of the foundation system of two-and-a-half times the frequency of impact or more may be considered satisfactory. When the natural frequency is designed to be less than the frequency

*Code of practice for subsurface investigations for foundations (*first revision*).

†Method of test for determination of dynamic properties of soils (*first revision*).

of impact, it shall be 30 percent or more below than the frequency of impact. For design, the combined natural frequency of the two-mass-spring system shall be considered.

4.2 Permissible Stresses

4.2.1 The total force acting on the pad and on the foundation support (see Fig. 1) shall be such that the deformation of the elastic material in them are within the allowable limits.

4.2.2 The load intensity on the soil below the foundation shall not be more than 80 percent of the allowable bearing pressure of the soil or material as the case may be.

4.3 Permissible Amplitudes

4.3.1 The permissible amplitudes which depend upon the mass of the tup shall be as follows:

| | <i>Mass of Tup</i> | | |
|----------------------|--------------------|---------------|-----------------------|
| | Up to 1 tonne | 1 to 3 tonnes | More than 3 tonnes |
| For foundation block | 1 mm | 1.5 mm | 2 mm |
| For anvil | 1 mm | 2 mm | 3 to 4 mm |

4.3.2 In case any important structure exists near the foundation, the amplitude of the foundation should be adjusted so that the velocity of the vibrations at the structure does not exceed 0.3 cm/s.

4.4 Dimensional Criteria

4.4.1 Area—The area of the foundation block at the base shall be such that the safe loading intensity of soil is never exceeded during the operation of the hammer.

4.4.2 Depth—The depth of the foundation block shall be so designed that the block is safe both in punching shear and bending. For the calculations the inertia forces developed shall also be included. However, the following minimum thickness of foundation block below the anvil shall be provided:

| <i>Mass of Tup</i> | <i>Thickness (Depth) of Foundation Block, Min</i> |
|--------------------|---|
| Tonnes | m |
| Up to 1.0 | 1.00 |
| 1.0 „ 2.0 | 1.25 |
| 2.0 „ 4.0 | 1.75 |
| 4.0 „ 6.0 | 2.25 |
| Over 6.0 | 2.50 |

4.4.3 Mass — The mass of the anvil is generally 20 times the mass of the tup. The mass of the foundation block (W_b) shall be at least 3 times that of the anvil.

For foundations resting on stiff clays or compact sandy deposits, the mass of block should be from 4 to 5 times the mass of the anvil.

For moderately firm to soft clays and for medium dense to loose sandy deposits, the mass of the block should be from 5 to 6 times the mass of the anvil.

5. VIBRATION ANALYSIS

5.1 Drop and Forge Hammers — The machine foundation system shall be analysed as a 2-mass system, with anvil forming one mass and the foundation block as the second mass. The analysis of a two-mass system is suggested in Appendix A. For analysis the dynamic force is calculated on the basis of momentum equation. In case of stray or random impact hammers (when the operating frequency is less than 150 strokes per minute) the natural frequencies need not be calculated. The deflection of the foundation under a single impact should be calculated. This deflection should be within permissible amplitudes. In case of high speed hammers (whose operating frequency is more than 150 strokes per minute) the detailed analysis will have to be conducted to determine the natural frequencies as well as the amplitudes.

5.2 Counter-Blow Hammers — In these hammers as no dynamic force is transmitted to the foundation, detailed vibration analysis is unnecessary. Only the natural frequencies should be determined to avoid resonance of the system.

6. CONSTRUCTION

6.1 The foundation block should be made of reinforced concrete. The concrete used shall be of grade not less than M 15 conforming to IS : 456-1978*.

6.2 It is desirable to cast the entire foundation block in one operation. If a construction joint is unavoidable, the plane of joint shall be horizontal and measures shall be taken to provide a proper joint. The following measures are recommended.

6.2.1 Dowels of 12 to 16 mm diameter at 60 mm centres should be embedded to a depth of at least 30 cm on both sides of the joint. Before placing the new layer of concrete, the previously laid surface should be roughened, thoroughly cleaned, washed by a jet of water and then covered

*Code of practice for plain and reinforced concrete (*third revision*).

by a layer of rich 1 : 2 cement grout, 2 cm thick. Concrete should be placed not later than 2 hours after the grout is laid.

6.3 Reinforcement shall be arranged along the three axis and also diagonally to prevent shear (*see* Fig. 2). More reinforcement shall be provided at the topside of the foundation block than at the other sides. Reinforcement at the top may be provided in the form of layers of grills made of 16 mm diameter bars suitably spaced to allow easy pouring of concrete. The topmost layers of reinforcement shall be provided with a cover of at least 5 cm. The reinforcement provided shall be at least 25 kg/m³ of concrete.

6.4 Special care shall be taken to provide accurate location of holes for anchor bolts (if any) cut out for anvil, frame, etc. The bearing surface for anvil shall be strictly horizontal and no additional corrective pouring of concrete shall be permitted.

6.5 The protective layer between anvil and foundation block shall be safeguarded against water, oil scales, etc, and the material selected should withstand temperatures up to 100°C.

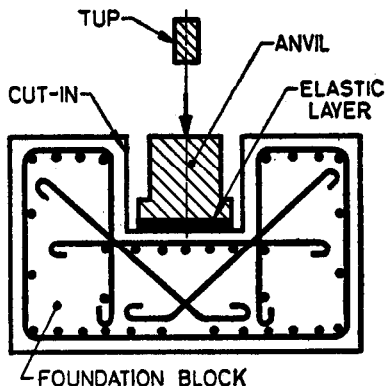

FIG. 2 TYPICAL REINFORCEMENT DETAIL

6.6 Air-gaps and spring elements provided for the purpose of damping vibrations shall be accessible in order to remove scales and enable inspection of springs and their replacement, if necessary.

6.7 Hammer foundations which are 'cut-in' by the anvil pits shall be made so deep that the parts which are weakened by the indent of 'cut-in' are of sufficient strength.

APPENDIX A

(Clause 5.1)

VIBRATION ANALYSIS OF A 2-MASS SYSTEM AND ITS APPLICATION TO DESIGN OF HAMMER FOUNDATIONS

A-1. ANALYSIS OF 2-MASS SYSTEM

A-1.1 The 2-mass system is represented by the model given in Fig. 3. The mass m_1 is subjected to a velocity of vibration of V_1 . The two natural frequencies f_{n1} and f_{n2} of the system are given by the positive roots of the following expressions:

$$f_n^4 - (f_{na}^2 + f_{nb}^2) (1 + \beta) f_n^2 + (1 + \beta) f_{na}^2 f_{nb}^2 = 0$$

where

$$f_{na} = \frac{1}{2\pi} \sqrt{\frac{k_1}{m_1}},$$

$$f_{nb} = \frac{1}{2\pi} \sqrt{\frac{k_2}{m_1 + m_2}}, \text{ and}$$

$$\beta = \frac{m_1}{m_2}.$$

The amplitude of vibrations are given by:

$$a_1 = \frac{(f_{na}^2 - f_{n2}^2) (f_{na}^2 - f_{n1}^2)}{2\pi f_{na}^2 (f_{n1}^2 - f_{n2}^2) f_{n2}} \cdot V_1, \text{ and}$$

$$a_2 = \frac{(f_{na}^2 - f_{n1}^2)}{2\pi (f_{n1}^2 - f_{n2}^2) f_{n2}} \cdot V_1$$

A-2. APPLICATION TO ANALYSIS OF HAMMER FOUNDATIONS

A-2.1 Notations

| | |
|--|--------------------------|
| Mass of the tup | W_t kg |
| Mass of the anvil | W_a kg |
| Mass of the frame | W_f kg |
| Height of fall of tup | h cm |
| Frequency of impact | N blows/min |
| Area of piston | A cm ² |
| Area of anvil base | A_a cm ² |
| Elastic modulus of the pad between anvil and foundation | E_1 kg/cm ² |

IS : 2974 (Part II) - 1980

| | |
|--|--------------------------|
| Thickness of pad | t_1 cm |
| Mass of foundation block | W_b kg |
| Area of foundation block | A_b cm ² |
| Equivalent radius of the base of foundation | r cm |
| Dynamic shear modulus of soil | G kg/cm ² |
| Coefficient of uniform elastic compression of soil | C_u kg/cm ³ |
| Spring coefficient of pile foundations | K_p kg/cm |
| Elastic modulus of pile material | E_p kg/cm ² |
| Cross-sectional area of pile | A_p cm ² |
| Length of pile | l cm |

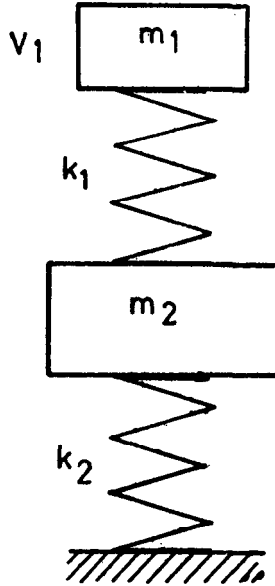

FIG. 3 MODEL SHOWING TWO-MASS SYSTEM

A-2.2 In a hammer foundation the first mass of the model corresponds to the anvil and the second mass to the foundation block. The mass of the frame will have to be added either to that of the anvil or to that of the foundation block depending upon whether the frame is attached to the anvil or to the block. The spring k_1 of the model corresponds to the elastic pad between the anvil and the block, while spring k_2 corresponds to the foundation support. The velocity V_1 is calculated on the basis of momentum equation.

A-2.2.1 These parameters can be calculated as below:

$$m_1 = \frac{W_a}{g}; m_2 = \frac{W_b}{g}$$

W_t will have to be added to either W_a or to W_b depending upon whether the frame is attached to anvil or to foundation block:

$$k_1 = \frac{E_1 \cdot A_s}{l_1} \text{ kg/cm,}$$

When the block is directly resting on soil:

$$k_2 = 7.6 rG \text{ or } A_b \cdot C_u \text{ kg/cm,}$$

When the block is supported on short bearing piles:

$$k_2 = \frac{k_p \cdot k_s}{k_p + k_s},$$

where

$$k_s = 7.6 rG \text{ or } A_b \cdot C_u, \text{ and}$$

$$k_p = \frac{n \cdot E_p \cdot A_p}{l}$$

For loose soils k_2 may be taken from settlement tests.

When springs are provided between the block and soil:

$$k_2 = \frac{k_{sp} \cdot k_s}{k_{sp} + k_s} \text{ kg/cm}$$

where

k_{sp} is the spring coefficient of springs,

$V_1 = V_{Aa}$ = Velocity of the anvil after impact, and

$$V_{Aa} = V_{tb} \cdot \frac{1+k}{1 + \frac{W_a}{W_t}}$$

where

$V_{tb} = \sqrt{2gh}$ for a freely falling tup type hammer, and

$= 0.65 \sqrt{2g \frac{(W_t + psA) h}{W_t}}$ for double acting steam hammer.

A-2.2.2 Check on Design

a) *Stability of the pad between anvil and block* — Total deflection of pad under impact = $\delta_1 = \delta_{1s} + \delta_{1d}$

where

$$\delta_{1s} = \frac{W_a}{k_1} \text{ cm}$$

NOTE — W_t will have to be added to W_a if the frame is attached to the anvil,

$$\text{and } \delta_{1d} = \frac{V_{Aa}}{2\pi f_{ns}}$$

The loading intensity on the pad

$$\sigma_1 = \frac{k_1 \cdot \delta_1}{A_a} \text{ kg cm}^2$$

δ_1 and σ_1 should be less than the allowable values for the pad.

b) Stability of the soil below the foundation:

$$\text{Loading intensity } \sigma_2 = \frac{W_a + W_b + W_f + k_z \alpha_\beta}{Ab}$$

where

$$\alpha_\beta = \frac{V_{\beta a}}{2\pi f_{nb}}; V_{\beta a} = V_{Aa} \frac{1+k}{1 + \frac{W_b}{W_a}}$$

(W_f will have to be added to W_b or to W_a depending upon whether the frame is attached to the block or to the anvil.)

σ_2 should be less than the allowable bearing pressure for the soil specified in 4.2.2.

c) Maximum deflection of the foundation under a single impact:

Assuming the anvil and the foundation block to be a single monolithic unit, the velocity after the impact:

$$V'_a = V_{tb} \frac{1+k}{1 + \frac{W_a + W_b + W_f}{W_f}} \text{ cm/s}$$

The natural frequency of the system = $f_{nb} \cdot H_z$

The deflection of the block $\delta = \frac{V'_a}{2\pi f_{nb}}$

should be less than the permissible amplitude for the block.

(Continued from page 2)

Foundations Subject to Dynamic Loads Subcommittee, BDC 43:1

| <i>Members</i> | <i>Representing</i> |
|---|--|
| SHRI N. K. BASU | Cemindia Company Limited, Calcutta |
| SHRI R. D. CHOUDHURY | Metallurgical & Engineering Consultants (India) Ltd, Ranchi |
| SHRI A. P. MUKHERJEE (<i>Alternate</i>) | |
| DIRECTOR (TCD) | Central Electricity Authority, New Delhi |
| DEPUTY DIRECTOR (TCD) (<i>Alternate</i>) | |
| SHRI M. IYENGAR | Engineers India Ltd, New Delhi |
| SHRI J. K. BAGCHI (<i>Alternate</i>) | |
| DR A. K. MUKHERJEE | Development Consultants Limited, Calcutta |
| SHRI S. K. RAY (<i>Alternate</i>) | |
| SHRI M. V. PANDIT | Bharat Heavy Electricals Limited, Bhopal |
| SHRI E. C. H. C. REDDY (<i>Alternate</i>) | |
| SHRI D. H. PATEL | Fertilizer India Limited, Dhanbad |
| SHRI N. S. DANI (<i>Alternate</i>) | |
| SHRI R. PURI | University of Roorkee, Roorkee |
| DR V. V. S. RAO | Nagadi Consultants Pvt Ltd, New Delhi |
| DR B. SHIVARAM | Central Building Research Institute (CSIR), Roorkee |
| DR P. SRINIVASULU | Structural Engineering Research Centre (CSIR), Roorkee |
| SHRI O. S. SRIVASTAVA | Cement Corporation of India, New Delhi |
| SHRI S. K. CHATTERJEE (<i>Alternate</i>) | |

BUREAU OF INDIAN STANDARDS

Headquarters:

Manak Bhavan, 9 Bahadur Shah Zafar Marg, NEW DELHI 110002

Telephones: 323 0131, 323 3375, 323 9402

Fax : 91 11 3234062, 91 11 3239399, 91 11 3239382

Telegrams : Manaksanstha
(Common to all Offices)

Central Laboratory :

Plot No. 20/9, Site IV, Sahibabad Industrial Area, Sahibabad 201010

Telephone
8-77 00 32

Regional Offices:

Central : Manak Bhavan, 9 Bahadur Shah Zafar Marg, NEW DELHI 110002 323 76 17

*Eastern : 1/14 CIT Scheme VII M, V.I.P. Road, Maniktola, CALCUTTA 700054 337 86 62

Northern : SCO 335-336, Sector 34-A, CHANDIGARH 160022 60 38 43

Southern : C.I.T. Campus, IV Cross Road, CHENNAI 600113 235 23 15

†Western : Manakalaya, E9, Behind Marol Telephone Exchange, Andheri (East),
MUMBAI 400093 832 92 95

Branch Offices::

'Pushpak', Nurmohamed Shaikh Marg, Khanpur, AHMEDABAD 380001 550 13 48

‡Peenya Industrial Area, 1st Stage, Bangalore-Tumkur Road,
BANGALORE 560058 839 49 55

Gangotri Complex, 5th Floor, Bhadbhada Road, T.T. Nagar, BHOPAL 462003 55 40 21

Plot No. 62-63, Unit VI, Ganga Nagar, BHUBANESHWAR 751001 40 36 27

Kalaikathir Buildings, 670 Avinashi Road, COIMBATORE 641037 21 01 41

Plot No. 43, Sector 16 A, Mathura Road, FARIDABAD 121001 8-28 88 01

Savitri Complex, 116 G.T. Road, GHAZIABAD 201001 8-71 19 96

53/5 Ward No.29, R.G. Barua Road, 5th By-lane, GUWAHATI 781003 54 11 37

5-8-56C, L.N. Gupta Marg, Nampally Station Road, HYDERABAD 500001 20 10 83

E-52, Chitaranjan Marg, C- Scheme, JAIPUR 302001 37 29 25

117/418 B, Sarvodaya Nagar, KANPUR 208005 21 68 76

Seth Bhawan, 2nd Floor, Behind Leela Cinema, Naval Kishore Road,
LUCKNOW 226001 23 89 23

NIT Building, Second Floor, Gokulpat Market, NAGPUR 440010 52 51 71

Patliputra Industrial Estate, PATNA 800013 26 23 05

Institution of Engineers (India) Building 1332 Shivaji Nagar, PUNE 411005 32 36 35

T.C. No. 14/1421, University P. O. Palayam, THIRUVANANTHAPURAM 695034 6 21 17

*Sales Office is at 5 Chowringhee Approach, P.O. Princep Street,
CALCUTTA 700072 27 10 85

†Sales Office is at Novelty Chambers, Grant Road, MUMBAI 400007 309 65 28

‡Sales Office is at 'F' Block, Unity Building, Narashimaraja Square,
BANGALORE 560002 222 39 71

AMENDMENT NO. 1 MAY 1984

TO

IS : 2974 (Part 2) – 1980 CODE OF PRACTICE FOR DESIGN
AND CONSTRUCTION OF MACHINE FOUNDATIONS

PART 2 FOUNDATIONS FOR IMPACT TYPE MACHINES
(HAMMER FOUNDATIONS)

(*First Revision*)

Alterations

(*Page 4, clause 1.1*) – Substitute the following for the existing:

'1.1 This standard (Part 2) covers the design and construction of hammer foundation subject to repeated impacts.'

(*Page 6, clause 2.4*):

- a) *Line 1* – Add the words '(see Fig. 1)' after 'support'.
- b) *Line 2* – Substitute the word 'soil' for 'ground'.

[*Pages 7 and 8, clause 4.1(c)*] – Delete.