

*Indian Standard*

**METHODS OF TESTING BOND IN  
REINFORCED CONCRETE**

**PART I PULL-OUT TEST**

( Fourth Reprint OCTOBER 1989 )

UDC 666.982:620.172.21

© Copyright 1968,

**BUREAU OF INDIAN STANDARDS**  
MANAK BHAVAN, 9 BAHADUR SHAH ZAFAR MARG  
NEW DELHI 110002

# *Indian Standard*

## METHODS OF TESTING BOND IN REINFORCED CONCRETE

### PART I PULL-OUT TEST

Cement and Concrete Sectional Committee, BDC 2

<i>Chairman</i>	<i>Representing</i>
SHRI K. K. NAMBIAR	The Concrete Association of India, Bombay
<i>Members</i>	
SHRI M. A. MEHTA ( <i>Alternate</i> to Shri K. K. Nambiar )	
SHRI K. F. ANTIA SHRI A. P. BAGCHI SHRI P. S. BHATNAGAR DR S. K. CHOPRA	M. N. Dastur & Co ( Pvt ) Ltd, Calcutta Sahu Cement Service, New Delhi Bhakra & Beas Designs Organization, New Delhi Central Building Research Institute ( CSIR ), Roorkee
SHRI J. S. SHARMA ( <i>Alternate</i> ) DIRECTOR ( CSM ) DIRECTOR ( DAMS III ) ( <i>Alternate</i> )	Central Water & Power Commission
DR R. K. GHOSH SHRI B. K. GUHA SUPERINTENDING ENGINEER, 2ND CIRCLE ( <i>Alternate</i> )	Indian Roads Congress, New Delhi Central Public Works Department
DR R. R. HATTIANGADI SHRI V. N. PAI ( <i>Alternate</i> )	The Associated Cement Companies Ltd, Bombay
JOINT DIRECTOR STANDARDS ( B & S ) DEPUTY DIRECTOR STANDARDS ( B & S ) ( <i>Alternate</i> )	Research, Design & Standards Organization ( Ministry of Railways )
SHRI S. B. JOSHI PROF S. R. MEHRA	S.B. Joshi & Co Ltd, Bombay Central Road Research Institute ( CSIR ), New Delhi
DR R. K. GHOSH ( <i>Alternate</i> ) SHRI S. N. MUKERJI SHRI E. K. RAMCHANDRAN ( <i>Alternate</i> )	National Test House, Calcutta
SHRI ERACH A. NADIRSHAH BRIG NARESH PRASAD SHRI C. B. PATEL SHRI RAJENDER SINGH ( <i>Alternate</i> )	Institute of Engineers ( India ), Calcutta Engineer-in-Chief's Branch, Army Headquarters National Buildings Organization
SHRI I. L. PATEL SHRI T. N. S. RAO SHRI S. R. PINHEIRO ( <i>Alternate</i> )	Directorate General of Supplies & Disposals Gammon India Ltd, Bombay
REPRESENTATIVE REPRESENTATIVE SHRI K. G. SALVI SHRI C. L. KASLIWAL ( <i>Alternate</i> )	Geological Survey of India, Calcutta The India Cements Ltd, Madras Hindustan Housing Factory Ltd, New Delhi

( Continued on page 2 )

**IS : 2770 ( Part I ) - 1967**

( Continued from page 1 )

<i>Members</i>	<i>Representing</i>
DR S. SARKAR	Structural Engineering Research Centre ( CSIR ), Roorkee
SHRI Z. GEORGE ( <i>Alternate</i> )	
SECRETARY	Central Board of Irrigation & Power, New Delhi
SHRI L. SWAROOP	Dalmia Cement ( Bharat ) Ltd, New Delhi
SHRI A. V. RAMANA ( <i>Alternate</i> )	
SHRI J. M. TREHAN	Roads Wing, Ministry of Transport
SHRI N. H. KESWANI ( <i>Alternate</i> )	
DR H. C. VISVESVARAYA	Cement Research Institute of India, New Delhi
SHRI R. NAGARAJAN, Director ( Civ Engg )	Director General, ISI ( <i>Ex-officio Member</i> )
	<i>Secretary</i>
	SHRI Y. R. TANEJA
	Deputy Director ( Civ Engg ), ISI
	Concrete Subcommittee, BDC 2 : 2
	<i>Convener</i>
SHRI S. B. JOSHI	S.B. Joshi & Co Ltd, Bombay
	<i>Members</i>
SHRI P. D. AHUJA	National Buildings Organization
SHRI P. C. JAIN ( <i>Alternate</i> )	
SHRI K. F. ANTIA	M.N. Dastur & Co (Pvt) Ltd, Calcutta
SHRI B. C. PATEL ( <i>Alternate</i> )	
SHRI A. P. BAGCHI	Sahu Cement Service, New Delhi
SHRI B. K. CHOKSI	In personal capacity ( <i>M 60, Cusrow Bag, Bombay</i> )
DR S. K. CHOPRA	Central Building Research Institute ( CSIR ), Roorkee
DR I. C. DOS M. PAIS CUDDOU	Central Water & Power Commission
DIRECTOR ( DAMS I ) ( <i>Alternate</i> )	
DEPUTY DIRECTOR STANDARDS ( B & S )	Research, Designs and Standards Organization
ASSISTANT DIRECTOR STANDARDS ( B & S ) ( <i>Alternate</i> )	
DIRECTOR	Hyderabad Engineering Research Laboratory, Hyderabad
DIRECTOR-IN-CHARGE	Geological Survey of India, Lucknow
SHRI V. N. GUNAJI	Public Works Department, Maharashtra
SHRI V. K. GUPTA	Engineer-in-Chief's Branch, Army Headquarters
SHRI K. K. NAMBIAR	The Concrete Association of India, Bombay
SHRI C. L. N. IVENGAR ( <i>Alternate</i> )	
DR M. L. PURI	Central Road Research Institute ( CSIR ), New Delhi
PROF G. S. RAMASWAMY	Structural Engineering Research Centre ( CSIR ), Roorkee
DR S. SARKAR ( <i>Alternate</i> )	
SHRI T. N. S. RAO	Gammon India Ltd, Bombay
SHRI S. R. PINHEIRO ( <i>Alternate</i> )	
SUPERINTENDING ENGINEER, 2ND CIRCLE	Central Public Works Department
SHRI S. G. VAIDYA ( <i>Alternate</i> )	
SHRI J. M. TREHAN	Roads Wing, Ministry of Transport
SHRI R. P. SIKKA ( <i>Alternate</i> )	
DR H. C. VISVESVARAYA	Cement Research Institute of India, New Delhi

*Indian Standard*  
METHODS OF TESTING BOND IN  
REINFORCED CONCRETE

PART I PULL-OUT TEST

0. FOREWORD

**0.1** This Indian Standard ( Part I ) was adopted by the Indian Standards Institution on 20 November 1967, after the draft finalized by the Cement and Concrete Sectional Committee had been approved by the Civil Engineering Division Council.

**0.2** This part deals with the method for comparison of the bond resistance of different types of reinforcing bars with concrete by pull-out test. The *Beam Tests* for determining the bond properties of reinforcing bars will be covered subsequently in separate parts.

**0.3** This method of test is intended to provide a standardized procedure for comparison of bond characteristics between concrete and different types of steel reinforcing bars. Such determinations may be made for any purpose, from routine acceptance tests to research testing, in so far as applicable to a particular project. The method is offered as one workable procedure, to be employed either in its entirety or with modifications to meet specific conditions. The method may also be used with some suitable modifications, if necessary, for comparing different concrete mixes for their bond characteristics with steel reinforcing bars.

**0.3.1** It should, however, not be assumed that the average bond stresses calculated from the results of such tests have any direct relation to the permissible bond stress given in Table VI of IS : 456-1964\*.

**0.4** The bond strength, or the measure of the effectiveness of the grip between concrete and steel, has no standard quantitative definition. In pull-out tests on plain bars, the maximum load generally represents the bond strength that can be developed between the concrete and steel. With plain bars the maximum load is not very different from the load at the first visible slip, but in the case of the deformed bar, the maximum load may correspond to a large slip which may not in fact be obtained in practice before other types of failure occur. It is preferable, therefore, when comparing plain and deformed bars to determine not only the maximum load but also the load at arbitrary amounts of slip and also plot the complete load-slip

\*Code of practice for plain and reinforced concrete ( *second revision* ).

curves for the plain and deformed bars under comparison. One such basis of comparison is the load at a relative movement ( slip ) between steel and concrete of 0.025 mm at the free end of the bar in a pull-out test.

**0.5** The Sectional Committee responsible for the preparation of this standard has taken into consideration the views of producers, consumers and technologists, and has related the standard to the manufacturing and trade practices followed in the country in this field. Due weightage has also been given to the need for international co-ordination among standards prevailing in different countries of the world. These considerations led the Sectional Committee to derive assistance from the published documents of the following organizations:

- American Society for Testing and Materials
- British Standards Institution
- Standards Association of Australia

**0.6** This standard is one of a series of Indian Standards on testing of concrete. Other standards published so far in the series are given on page 10.

**0.7** In reporting the results of a test or analysis made in accordance with this standard, if the final value observed or calculated, is to be rounded off, it shall be done in accordance with IS : 2-1960\*.

---

## **1. SCOPE**

**1.1** This standard ( Part I ) covers the method for the comparison of the bond resistance of different types of reinforcing bars with concrete by means of a pull-out test.

## **2. APPARATUS**

**2.1 Moulds for Bond Test Specimens** — The moulds shall be of size suitable for casting concrete cubes of dimensions specified in **3.1** and shall conform to the requirements of compression test specimens specified in IS : 516-1959†.

The moulds shall be watertight. Watertightness may be accomplished by using grooved joints, or a sealing compound may be applied at the joints after assembly. The moulds shall be designed to hold the bars rigidly in place and shall allow for easy removal without disturbance of embedded bars.

**2.2 Measuring Apparatus** — Apparatus shall be provided for measuring the movement of the reinforcing bar with respect to the concrete at both the loaded and unloaded ( free ) ends of the bar. Dial micrometers shall

---

†Rules for rounding off numerical values ( revised ).

‡Methods of test for strength of concrete.

be used at both locations. At the free end of the bar a dial micrometer graduated to read in 0.0025 mm and having a range of not less than 25 mm shall be used. At the loaded end, dial micrometers graduated in 0.025 mm will be satisfactory, but a range of at least 12.5 mm should be provided, and a range of 25 mm is desirable ( *see Note* ).

**NOTE** — One type of apparatus that has been found satisfactory is shown in Fig. 1. The dial micrometers are mounted on suitable yokes which are attached to the concrete specimen with set screws. At the unloaded end of the bar the gauge can be adjusted by means of the threaded bolt with which it is attached to the yoke. At the loaded end of the bar, adjustment is accomplished by changing the height of the cap screws on the ends of the cross-bar on which the stems of the dial micrometers bear. The split ring cross-bar is attached to the reinforcing bar through four screws in the arms of the cross-bar which bring the gasket rubber lining into firm contact with the reinforcing bar. The three set screws as shown are used to ensure additional cross-bar contact. The cross-bar rests in a slot machined in the intermediate bearing plate.

**2.3 Testing Machine** — The testing machine may be of any reliable type, of sufficient capacity for the tests and capable of applying the load at the rate specified in 4.2. The bearing surface of the concrete cube shall be supported on a square machined steel plate of size not less than the size of the test cube ( *see 3.1* ) and 20 mm thick, with a hole drilled through its centre of sufficient diameter to accommodate the reinforcing bar. If a cross-bar measuring apparatus similar to that shown in Fig. 1 is used, this plate should be supported on a steel block at least 125 mm in diameter and 75 mm thick. This block should have a central hole to accommodate the reinforcing bar, and in addition, on its top side should have a diametral slot and central hole of dimensions sufficient to accommodate the cross-bar. This slotted block shall rest in turn on a spherically seated bearing block at least 125 mm in diameter and having a central hole at least 40 mm in diameter ( *see Fig. 1* ).

**2.4 Tamping Rod** — The tamping rod shall be a round, straight steel rod 15 mm in diameter and approximately 0.6 m in length, having the tamping end rounded to a hemispherical tip, 15 mm in diameter.

### 3. TEST SPECIMENS

**3.1 Size of the Test Specimen** — The test specimens shall consist of concrete cubes of size given below, with a single reinforcing bar embedded vertically along a central axis in each specimen. The bar shall project down for a distance of about 10 mm from the bottom face of the cube as cast, and shall project upward from the top face whatever distance is necessary to provide sufficient length of bar to extend through the bearing blocks and the support of the testing machine and to provide an adequate length to be gripped for application of load:

<i>Diameter of the Bars</i>	<i>Size of the Cube</i>
mm	mm
Up to and including 12	100
Over 12 up to and including 25 mm	150
Over 25 mm	225

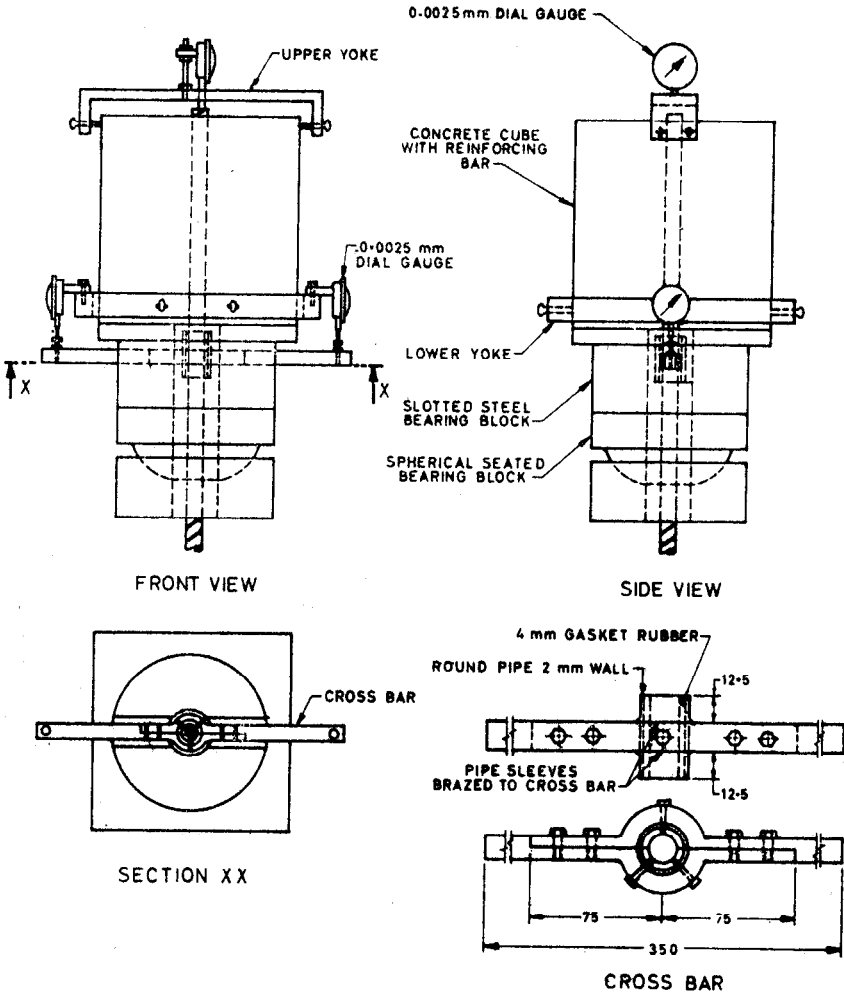

All dimensions in millimetres.

FIG. 1 TYPICAL MEASURING AND TESTING APPARATUS FOR BOND TEST

**3.1.1** The cube shall be reinforced with a helix of 6 mm diameter plain mild steel reinforcing bar conforming to Grade I of IS : 432 ( Part I ) - 1966\* or IS : 226-1962† at 25 mm pitch, such that the outer diameter of

\*Specification for mild steel and medium tensile steel bars and hard-drawn steel wire for concrete reinforcement: Part I Mild steel and medium tensile steel bars ( second revision ).

†Specification for structural steel ( standard quality ) ( third revision ). ( Since revised ).

the helix is equal to the size of the cube, each end of the helix being welded to the next turn.

**3.1.2** The average compressive strength of three cubes representing the concrete used for test specimen in **3.1**, made and tested in accordance with relevant requirements of IS : 516-1959\* shall be 200 to 300 kg/cm<sup>2</sup> at the time of making the pull-out tests. If the range of the compression strength of three cubes tested exceeds 50 kg/cm<sup>2</sup>, the test series shall be discarded. All test specimens and the control cubes required to establish the strength of concrete shall be cured under similar conditions.

**3.1.3** For the purpose of comparing bond resistance of deformed bars and plain bars, the concrete used in both tests should be of the same mix, strength, age and curing. The bars to be tested shall also be of same cross-sectional area and have similar surface conditions ( *see* Note under **5.2.1** ).

## **3.2 Preparation of Test Specimen**

**3.2.1 Bars** — Loose scale and rust shall be thoroughly removed from the bars by wire brushing and bars inspected to ensure that they are free from grease, paint, or other coatings which would affect their bond. Suitable solutions may also be applied, if necessary, to clean the grease or oil. The end of the reinforcing bars on which the stem of the dial gauge is to bear in the test, shall be ground to a reasonably smooth surface normal to the axes of the bars.

**3.2.2 Mixing Concrete** — Except in those tests for which the method of mixing concrete is a controlled variable, the concrete shall be mixed in accordance with the relevant requirements of the method of making and curing concrete compression test specimens in the laboratory specified in IS : 516-1959\*. The consistency of each batch of concrete shall be measured immediately after mixing. When the air content of the freshly mixed concrete is also required to be known, the determination shall be made in accordance with the relevant requirements of IS : 1199-1959†.

**3.2.3 Moulding and Curing Specimens** — Except in those tests for which the method of placing concrete in moulds is a controlled variable, the specimens shall be moulded and cured in accordance with the requirements of the method of making and curing concrete compression test specimen in laboratory ( compaction by hand ) specified in IS : 516-1959\* ( *see* Note ). After the top layer has been rodded, the surface shall be struck off with a trowel and covered with damp burlap to prevent evaporation.

**NOTE** — If concrete of very dry consistency is used, the recommended procedure of compacting by rodding may prove unsatisfactory. In such cases, it is recommended

\*Methods of test for strength of concrete.

†Methods of sampling and analysis of concrete.



## IS : 2770 ( Part I ) - 1967

that placement by vibration be used. Internal vibration by means of a laboratory type, low-amplitude, high-frequency vibrator is preferable. The concrete shall be placed in the moulds in two layers of equal thickness and each layer shall be vibrated until the concrete is compacted. Care shall be taken not to vibrate the concrete excessively, unless this factor is being investigated in the tests.

**3.3 Number of Specimens** — At least three specimens of the deformed bar submitted for test and three comparative specimens of plain bars of the same effective cross-sectional area as the deformed bars under test, shall be prepared and tested.

**3.4 Preparing Specimens for Testing** — Top surface of the cube, which is the bearing surface in the pull-out test, shall be capped with a thin layer of neat cement paste at least 24 h prior to testing, or a thin layer of high-strength gypsum plaster shall be applied at least 2 h prior to testing ( *see Note* ).

NOTE — The recommended procedure for capping specimens is as follows:

Align the reinforcing bar in the bond specimens vertically by use of a carpenter's level. In this case, placing the specimens on the base of mould vertically cast specimens will facilitate use of shims generally required to align bars. Oil the 20 mm drilled steel plate used in the pull-out operation and use as the capping plate. After a sufficient quantity of capping material has been placed on the specimen, slip the 20 mm drilled plate over the reinforcing bar and press firmly on the capping material until it extrudes at all edges of the plate. Level the drilled plate with a carpenter's level. Removal of the material that extrudes through the drilled hole in the plate before it hardens will aid in removing the plate without damage to the cap. Unless machined moulds are used for specimens containing horizontally cast bars, it is recommended that they also be capped.

## 4. TEST PROCEDURE

**4.1** The test specimen shall be mounted in a suitable testing machine in such a manner that the bar is pulled axially from the cube. The end of the bar at which the pull is applied shall be that which projects from the top face of the cube as cast.

**4.1.1** In assembling the testing apparatus on the specimen the distance between the face of the concrete and the point on the loaded end of the reinforcing bar at which the device for measuring slip is attached, shall be carefully measured so that the elongation of the bar over this distance may be calculated and deducted from the measured slip.

**4.2** The load shall be applied to the reinforcing bar at a rate not greater than 2.250 kg/min, or at no-load speed of the testing machine head of not greater than 1.25 mm/min, depending on the type of testing machine used and the means provided for ascertaining or controlling speeds.

**4.3** The movement between the reinforcing bar and the concrete cube, as indicated by the dial micrometers shall be read at a sufficient number of intervals throughout the test to provide at least 15 readings by the time

a slip of 0.25 mm has occurred at the loaded end of the bar. The dial micrometers shall be read at the loaded and unloaded ends and reading recorded to an estimated 0.1 of the least division of the dial.

**4.3.1** The loading shall be continued and readings of movements recorded at appropriate intervals until:

- a) the yield point of the reinforcing bars has been reached,
- b) the enclosing concrete has failed ( the type of failure shall be noted ), or
- c) a minimum slippage of 2.5 mm has occurred at the loaded end.

**4.3.1.1** The maximum load for each type of failure shall be recorded.

**4.4** For the purpose of comparison the bond resistance of deformed bars and plain bars, the comparison of bond strengths shall be made on the basis of the average bond stresses calculated from the loads at a measured slip of 0.025 mm at free end. It is recommended that when comparing plain and deformed bars, the complete load-slip curves of both should also be plotted. The following details shall be recorded:

- a) The load at a slip of 0.025 mm at the free end, and
- b) The load at a slip of 0.25 mm at the free end.

## 5. CALCULATION OF BOND STRESS

**5.1** The slip at the loaded end of the bar shall be calculated as the average of the readings of the two dial gauges, corrected for the elongation of the reinforcing bar in the distance between the bearing surface of the concrete block and point on the reinforcing bar at which the measuring device was attached.

**NOTE** — Theoretically, a similar correction is required for the compression of the concrete between the bearing surface and the point at which the yoke holding the dials is attached, if the apparatus illustrated in Fig. 1 is used. This movement, however, is usually very small and may be neglected.

**5.2** For the purpose of this test, the average bond stress shall be the value obtained for each specimen, by dividing the applied load at the slip specified, by the surface area of the embedded length of the bar; and then taking the average value for the group of each type of bar in the test series.

**5.2.1** For deformed bars, the surface shall be calculated from the nominal size of the deformed bar as specified in the relevant standard specification.

**NOTE** — As per IS : 1139-1966\*, the nominal size of a deformed bar is equivalent to the diameter or side of a plain bar having the same weight per metre run as the deformed bar.

\*Specification for hot rolled mild steel and medium tensile steel deformed bars for concrete reinforcement ( revised ).

**6. RECORD OF RESULTS**

**6.1** The following details shall be recorded:

- a) The crushing strength of the concrete cube at an age corresponding to the age of the specimen at the time of making the pull-out tests,
- b) The age of specimen,
- c) The load at a slip of 0.025 mm at the free end,
- d) The load at a slip of 0.25 mm at the free end,
- e) The slips at free and loaded ends at regular intervals of loading, and
- f) The maximum load at failure and the type of failure.

---

**INDIAN STANDARDS**

**ON**

**Testing of Concrete**

IS:					Rs
516-1959	Methods of test for strength of concrete	...	...	...	5.00
1199-1959	Methods of sampling and analysis of concrete	...	...	...	7.50

# BUREAU OF INDIAN STANDARDS

## Headquarters:

Manak Bhavan, 9 Bahadur Shah Zafar Marg, NEW DELHI 110002

Telephones: 331 01 31, 331 13 75

Telegrams: Manaksanstha  
( Common to all Offices )

## Regional Offices:

Telephone

Central : Manak Bhavan, 9 Bahadur Shah Zafar Marg,  
NEW DELHI 110002

{ 331 01 31  
331 13 75

\*Eastern : 1/14 C. I. T. Scheme VII M, V. I, P. Road,  
Maniktola, CALCUTTA 700054

36 24 99

Northern : SCO 445-446, Sector 35-C,  
CHANDIGARH 160036

{ 2 18 43  
3 16 41

Southern : C. I. T. Campus, MADRAS 600113

{ 41 24 42  
41 25 19  
41 29 16

†Western : Manakalaya, E9 MIDC, Marol, Andheri ( East ),  
BOMBAY 400093

6 32 92 95

## Branch Offices:

'Pushpak', Nurmohamed Shaikh Marg, Khanpur,  
AHMADABAD 380001

{ 2 63 48  
2 63 49

‡Peenya Industrial Area 1st Stage, Bangalore Tumkur Road  
BANGALORE 560058

{ 38 49 55  
38 49 56

Gangotri Complex, 5th Floor, Bhadbhada Road, T. T. Nagar,  
BHOPAL 462003

6 67 16

Plot No. 82/83, Lewis Road, BHUBANESHWAR 751002

5 36 27

53/5, Ward No. 29, R.G. Barua Road, 5th Byelane,  
GUWAHATI 781003

3 31 77

5-8-56C L. N. Gupta Marg ( Nampally Station Road ),  
HYDERABAD 500001

23 10 83

R14 Yudhister Marg, C Scheme, JAIPUR 302005

{ 6 34 71  
6 98 32

117/418 B Sarvodaya Nagar, KANPUR 208005

{ 21 68 76  
21 82 92

Patliputra Industrial Estate, PATNA 800013

6 23 05

T.C. No. 14/1421, University P.O., Palayam  
TRIVANDRUM 695035

{ 6 21 04  
6 21 17

## Inspection Offices ( With Sale Point ):

Pushpanjali, First Floor, 205-A West High Court Road,  
Shankar Nagar Square, NAGPUR 440010

2 51 71

Institution of Engineers ( India ) Building, 1332 Shivaji Nagar,  
PUNE 411005

5 24 35

\*Sales Office in Calcutta is at 5 Chowringhee Approach, P. O. Princep Street, Calcutta 700072

†Sales Office in Bombay is at Novelty Chambers, Grant Road, Bombay 400007

‡Sales Office in Bangalore is at Unity Building, Narasimharaja Square, Bangalore 560002