

*Indian Standard*  
METHODS OF TEST FOR  
AGGREGATES FOR CONCRETE

PART II ESTIMATION OF DELETERIOUS MATERIALS  
AND ORGANIC IMPURITIES

(Ninth Reprint FEBRUARY 1998 )

UDC 691.322 : 543.86

© Copyright 1963

BUREAU OF INDIAN STANDARDS  
MANAK BHAVAN, 9 BAHADUR SHAH ZAFAR MARG  
NEW DELHI 110002

*Indian Standard***METHODS OF TEST FOR  
AGGREGATES FOR CONCRETE****PART II ESTIMATION OF DELETERIOUS MATERIALS  
AND ORGANIC IMPURITIES****Cement and Concrete Sectional Committee, BDC 2***Chairman***SHRI K. K. NAMBIAR***Representing***The Concrete Association of India, Bombay***Members***SHRI K. V. THADANEY (Alternate to  
Shri K. K. Nambiar)****SHRI K. F. ANTIA****M. N. Dastur & Co Private Ltd, Calcutta****SHRI P. S. BHATNAGAR****Bhakra Dam Designs Directorate, New Delhi****DR I. C. DOS M. PAIS CUDDOU****Central Water & Power Commission (Ministry of  
Irrigation & Power)****SHRI Y. K. MURTHY (Alternate)****SHRI N. D. DARTARY****Khira Steel Works Private Ltd, Bombay****SHRI N. G. DEWAN****Central Public Works Department****SUPERINTENDING ENGINEER,  
2ND CIRCLE (Alternate)****DR R. R. HATTIANGADI****The Associated Cement Companies Ltd, Bombay****SHRI V. N. PAI (Alternate)****SHRI P. C. HAZRA****Geological Survey of India, Calcutta****JOINT DIRECTOR STANDARDS  
(B&S)****Research, Designs & Standards Organization  
(Ministry of Railways)****ASSISTANT DIRECTOR STAND-  
ARDS (B&S) (Alternate)****SHRI S. B. JOSHI****S. B. Joshi & Co Private Ltd, Bombay****SHRI M. M. LAL****U. P. Government Cement Factory, Churk****SHRI B. N. MAJUMDAR****Directorate General of Supplies & Disposals  
(Ministry of Economic & Defence Co-ordination)****SHRI P. L. DAS (Alternate)****PROF S. R. MEHRA****Central Road Research Institute (CSIR),  
New Delhi****SHRI N. H. MOHILE****The Concrete Association of India, Bombay****SHRI S. N. MUKEJI****Government Test House, Calcutta****SHRI N. C. SEN GUPTA (Alternate)****SHRI ERACH A. NADIRSHAH****Institution of Engineers (India), Calcutta****SHRI C. B. PATEL****National Buildings Organisation (Ministry of  
Works, Housing & Rehabilitation)****SHRI RABINDER SINGH (Alternate)****PROF G. S. RAMASWAMY****Central Building Research Institute (CSIR),  
Roorkee****SHRI K. SIVA PRASAD (Alternate)***(Continued on page 2)*

( Continued from page 1 )

<i>Members</i>	<i>Representing</i>
<b>SRI T. N. S. RAO</b>	Gammon India Ltd, Bombay
<b>SRI S. R. PINHEIRO ( Alternate )</b>	
<b>REPRESENTATIVE</b>	Martin Burn Ltd, Calcutta
<b>SRI NIHAR CHANDRA ROY</b>	Dalmia Cement ( Bharat ) Ltd, Calcutta
<b>SECRETARY</b>	Central Board of Irrigation & Power ( Ministry of Irrigation & Power )
<b>BRIG G. S. SIHOTA</b>	Engineer-in-Chief's Branch, Army Headquarters
<b>SRI R. S. MEHANDRU ( Alternate )</b>	
<b>DR BH. SUBBARAJU</b>	Indian Roads Congress, New Delhi
<b>SRI J. M. TREHAN</b>	Roads Wing, Ministry of Transport & Communications
<b>SRI N. H. KESWANI ( Alternate )</b>	
<b>DR H. C. VISVESVARAYA,</b> Deputy Director ( Bldg )	Director, ISI ( <i>Ex-officio Member</i> )

*Secretary*  
**SRI A. PRITHVI RAJ**  
Extra Assistant Director ( Bldg ), ISI  
Concrete Subcommittee, BDC 2 : 2

<i>Convener</i>	
<b>SRI S. B. JOSHI</b>	S.B. Joshi & Co. Private Ltd, Bombay
<i>Members</i>	
<b>ASSISTANT DIRECTOR STANDARDS ( B&amp;S )</b>	Research, Designs & Standards Organization ( Ministry of Railways )
<b>SRI N. H. BHAGWANANI</b>	Engineer-in-Chief's Branch, Army Headquarters
<b>DR I. C. DOS M. PAIS CUDDOU</b>	Central Water & Power Commission ( Ministry of Irrigation & Power )
<b>SRI Y. K. MURTHY ( Alternate )</b>	
<b>SRI P. L. DAS</b>	Directorate General of Supplies & Disposals ( Ministry of Economic & Defence Co-ordination )
<b>SRI B. N. MAJUMDAR ( Alternate )</b>	
<b>DIRECTOR</b>	Engineering Research Laboratory, Hyderabad
<b>SRI V. N. GUNAJI</b>	Maharashtra Public Works Department
<b>SRI M. A. HAFEEZ</b>	National Buildings Organisation ( Ministry of Works, Housing & Rehabilitation )
<b>SRI B. S. SHIVAMURTHY ( Alternate )</b>	
<b>SRI C. L. HANDA</b>	Central Water & Power Commission ( Ministry of Irrigation & Power )
<b>SRI P. C. HAZRA</b>	Geological Survey of India, Calcutta
<b>SRI K. K. NAMBIAR</b>	The Concrete Association of India, Bombay
<b>SRI C. L. N. IYENGAR ( Alternate )</b>	
<b>DR M. L. PURI</b>	Central Road Research Institute ( CSIR ), New Delhi
<b>PROF G. S. RAMASWAMY</b>	Central Building Research Institute ( CSIR ), Roorkee
<b>SRI K. SIVA PRASAD ( Alternate )</b>	
<b>SRI T. N. S. RAO</b>	Gammon India Ltd, Bombay
<b>SRI S. R. PINHEIRO ( Alternate )</b>	
<b>SUPERINTENDING ENGINEER, 2ND CIRCLE</b>	Central Public Works Department
<b>SRI O. P. GOEL ( Alternate )</b>	
<b>SRI J. M. TREHAN</b>	Roads Wing, Ministry of Transport & Communications
<b>SRI R. P. SIKKA ( Alternate )</b>	
<b>SRI H. T. YAN</b>	Braithwaite Burn & Jessop Construction Co Ltd, Calcutta

*Indian Standard***METHODS OF TEST FOR  
AGGREGATES FOR CONCRETE****PART II ESTIMATION OF DELETERIOUS MATERIALS  
AND ORGANIC IMPURITIES****0. FOREWORD**

**0.1** This Indian Standard ( Part II ) was adopted by the Indian Standards Institution on 22 August 1963, after the draft finalized by the Cement and Concrete Sectional Committee had been approved by the Building Division Council.

**0.2** One of the major contributing factors to the quality of concrete is the quality of aggregates used therein. The test methods given in this standard are intended to assist in assessing the quality of aggregates. In a given situation, for a particular aggregate, it may not be necessary to assess all the qualities and therefore it is necessary to determine beforehand the purpose for which a concrete is being used and the qualities of the aggregate which require to be assessed. Accordingly, the relevant test methods may be chosen from amongst the various tests covered in this standard. For the convenience of the users the test methods are grouped into the following eight parts of Indian Standard Methods of Test for Aggregates for Concrete ( IS : 2386-1963 ):

Part I	Particle Size and Shape
Part II	Estimation of Deleterious Materials and Organic Impurities
Part III	Specific Gravity, Density, Voids, Absorption and Bulking
Part IV	Mechanical Properties
Part V	Soundness
Part VI	Measuring Mortar Making Properties of Fine Aggregate
Part VII	Alkali Aggregate Reactivity
Part VIII	Petrographic Examination

**0.3** The Sectional Committee responsible for the preparation of this standard has taken into consideration the views of the concrete specialists,

testing authorities, consumers and technologists and has related the standard to the practices followed in this country. Further the need for international co-ordination among standards prevailing in different countries of the world has also been recognised. These considerations led the Sectional Committee to derive assistance from the published standards and publications of the following organizations:

British Standards Institution

American Society for Testing and Materials

**0.4** Wherever a reference to any Indian Standard appears in these methods, it shall be taken as a reference to its latest version.

**0.5** For the purpose of deciding whether a particular requirement of this standard is complied with, the final value, observed or calculated, expressing the result of a test or analysis, shall be rounded off in accordance with IS : 2-1960 Rules for Rounding Off Numerical Values ( *Revised* ). The number of significant places retained in the rounded off value should be the same as that of the specified value in this standard.

**0.6** This standard is intended chiefly to cover the technical provisions relating to testing of aggregates for concrete, and it does not cover all the necessary provisions of a contract.

---

## **1. SCOPE**

**1.1** This standard ( Part II ) covers the following tests for aggregates for concrete:

- a) Determination of clay lumps,
- b) Determination of clay, fine silt and fine dust ( sedimentation method ),
- c) Determination of light-weight pieces ( coal and lignite ),
- d) Determination of soft particles, and
- e) Estimation of organic impurities.

## **2. DETERMINATION OF CLAY LUMPS**

**2.1 Object** — This method of test covers the procedure for the approximate determination of clay lumps in the routine examination of aggregates.

**2.2 Apparatus** — The apparatus shall consist of the following:

- a) *Balance* — A balance or scale sensitive to within 0.1 percent of the weight of the sample to be weighed.
- b) *Containers* — Containers of a size and shape that will permit the spreading of the sample on the bottom in a thin layer.
- c) *Sieves* — Sieves conforming to IS : 460-1962 Specification for Test Sieves (*Revised*).

### 2.3 Sampling

**2.3.1** Samples shall be obtained by quartering or by the use of a sampler, from a representative sample selected from the material to be tested. They shall be handled in such a manner as to avoid breaking up clay lumps which may be present.

**2.3.2** Samples shall be dried to constant weight at a temperature not exceeding 110°C.

**2.3.3** Samples of fine aggregate shall consist of particles coarser than 1.18-mm IS Sieve and shall weigh not less than 100 g.

**2.3.4** Samples of coarse aggregate shall be separated into different sizes using 4.75-mm, 10-mm, 20-mm and 40-mm IS Sieves. The weight of the sample for different sizes shall be not less than those indicated below:

<i>Size of Particles Making Up the Samples</i>	<i>Weight of Sample Min</i>
mm	g
Over 4.75 to 10	1 000
" 10 " 20	2 000
" 20 " 40	3 000
" 40	5 000

**2.3.5** In the case of mixtures of fine and coarse aggregates, the material shall be separated into two sizes on 4.75-mm IS Sieve, and the samples of fine and coarse aggregates shall be prepared as described under 2.3.3 and 2.3.4.

**2.4 Procedure** — The sample shall be spread in a thin layer on the bottom of the container and examined for clay lumps. Any particles

which can be broken into finely divided particles with the fingers, shall be classified as clay lumps. After all discernible clay lumps have been broken, the residue from the clay lumps shall be removed by the use of sieves indicated below:

<i>Size of Particles Making Up the Sample</i>	<i>Size of Sieve for Sieving Residue of Clay Lumps</i>
Fine aggregate ( retained on 1.18-mm IS Sieve )	850-micron
Over 4.75 mm to 10 mm	2.36 mm
„ 10 mm to 20 mm	4.75 mm
„ 20 mm to 40 mm	4.75 mm
„ 40 mm	4.75 mm

**2.5 Calculation** — The percentage of clay lumps shall be calculated to the nearest 0.1 percent in accordance with the following formula:

$$L = \frac{W - R}{W} \times 100$$

where

$L$  = percentage of clay lumps,

$W$  = weight of sample, and

$R$  = weight of sample after removal of clay lumps.

**2.6 Reporting of Results** — The percentage of clay lumps in the aggregate shall be reported to the nearest 0.1 percent.

### 3. DETERMINATION OF CLAY, FINE SILT AND FINE DUST (SEDIMENTATION METHOD)

**3.1 Object** — This is a gravimetric method for determining the clay, fine silt and fine dust, which includes particles up to 20 micron. Differences in the nature and density of materials or in the temperature at the time of testing may vary the separation point.

**3.2 Apparatus** — The apparatus shall consist of the following:

- a) A watertight screw-topped glass jar of dimensions similar to a 1-kg fruit preserving jar.
- b) A device for rotating the jar about its long axis, with this axis horizontal, at a speed of  $80 \pm 20$  rev/min.

- c) A sedimentation pipette of the Andreason type of approximately 25 ml capacity and of the general form indicated in Fig. 1. This consists mainly of a pipette fitted at the top with a two-way tap and held rigidly in a clamp which can be raised or lowered as required, and which is fitted with a scale from which the changes in height of the pipette can be read.

The volume of the pipette *A*, including the connecting bore of the tap *B*, is determined by filling with distilled water; by reversing the tap, the water is run out into a bottle, weighed and the volume calculated.

- d) A 1 000-ml measuring cylinder.
- e) A scale or balance of capacity not less than 10 kg, readable and accurate to one gram.
- f) A scale or balance of capacity not less than 250 g, readable and accurate to 0.001 g.
- g) A well-ventilated oven, thermostatically controlled, to maintain a temperature of 100 to 110°C.

**3.3 Chemicals** — A solution containing 8 g of sodium oxalate per litre of distilled water shall be taken. For use, this stock solution is diluted with distilled water to one tenth ( that is 100 ml diluted with distilled water to one litre ).

**3.4 Test Sample** — The sample for test shall be prepared from the main sample taking particular care that the test sample contains a correct proportion of the finer material. The amount of sample taken for test shall be in accordance with Table F.

**TABLE I WEIGHT OF SAMPLE FOR DETERMINATION OF CLAY, FINE SILT AND FINE DUST**

MAXIMUM SIZE PRESENT IN SUBSTANTIAL PROPORTIONS	APPROXIMATE WEIGHT OF SAMPLE FOR TEST
mm	kg
63 to 25	6
20 to 12.5	1
10 to 6.3	0.5
4.75 or smaller	0.3

**3.4.1** All-in aggregates shall be separated into fine and coarse fractions by sieving on a 4.75-mm IS Sieve and the two samples so obtained shall be tested separately.



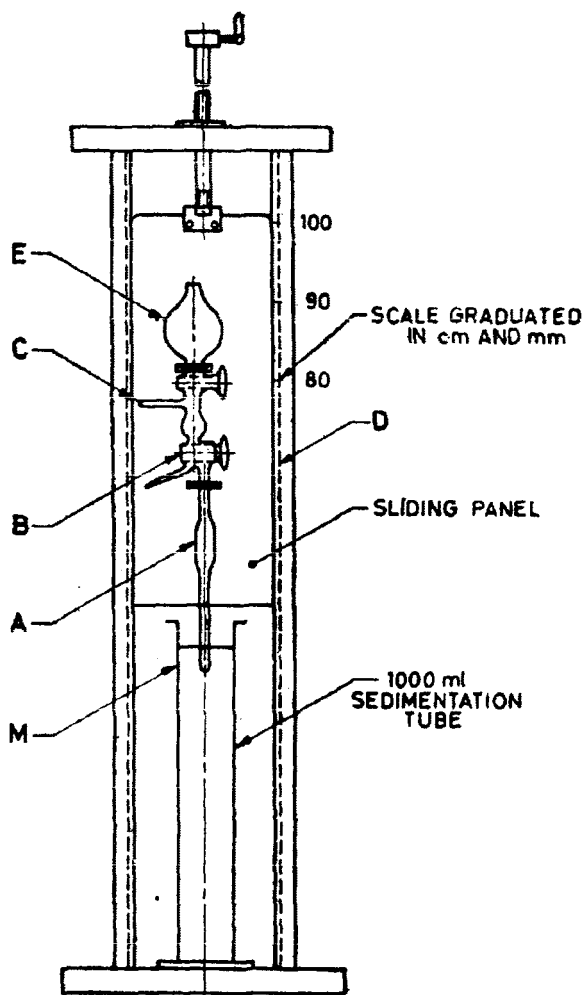

FIG. 1 SEDIMENTATION PIPETTE FOR DETERMINATION OF CLAY AND SILT CONTENT

### 3.5 Test Procedure

**3.5.1 Method for Fine Aggregate** — Approximately 300 g of the sample in the air-dry condition, passing the 4.75-mm IS Sieve, shall be weighed and placed in the screw-topped glass jar, together with 300 ml of the diluted sodium oxalate solution. The rubber washer and cap shall be fixed, care being taken to ensure watertightness. The jar shall then be

rotated about its long axis, with this axis horizontal, at a speed of  $80 \pm 20$  rev/min for a period of 15 minutes.

**3.5.1.1** At the end of 15 minutes, the suspension shall be poured into the 1 000-ml measuring cylinder and the residue washed by gentle swirling and decantation of successive 150-ml portions of sodium oxalate solution, the washings being added to the cylinder until the volume is made up to 1 000 ml. The determination shall be completed as described in 3.5.3.

**3.5.2 Method for Coarse Aggregate** — The weighed sample shall be placed in a suitable container, covered with a measured volume of sodium oxalate solution (0.8 g per litre), agitated vigorously to remove all adherent fine material and the liquid suspension transferred to the 1 000-ml measuring cylinder. This process shall be repeated as necessary until all clayey material has been transferred to the cylinder. The volume shall be made up to 1 000 ml with sodium oxalate solution and the determination completed as described in 3.5.3.

**3.5.3** The suspension in the measuring cylinder shall be thoroughly mixed by inversion and the tube and contents immediately placed in position under the pipette. The pipette *A* shall then be gently lowered until the tip touches the surface of the liquid, and then lowered a further 10 cm into the liquid. Three minutes after placing the tube in position, the pipette *A* and the bore of tap *B* shall be filled by opening *B* and applying gentle suction at *C*. A small surplus may be drawn up into the bulb between tap *B* and tube *C*, but this shall be allowed to run away and any solid matter shall be washed out with distilled water from *E*. The pipette shall then be removed from the measuring cylinder and its contents run into a weighed container, any adherent solids being washed into the container by distilled water from *E* through the tap *B*.

The contents of the container shall be dried at 100 to 110°C to constant weight, cooled and weighed.

**3.6 Calculations** — The proportion of fine silt and clay or fine dust shall then be calculated from the following formula:

$$\text{Percentage of clay and fine silt or fine dust} = \frac{100}{W_1} \left( \frac{1\,000 W_2}{V} - 0.8 \right)$$

where

$W_1$  = weight in g of the original sample,

$W_2$  = weight in g of the dried residue,

$V$  = volume in ml of the pipette, and

0.8 = weight in g of sodium oxalate in one litre of the diluted solution.

**NOTE** — No correction is made for water soluble salts which may be present in the sand, since the amount of such salts should be small.

**3.7 Reporting of Results** — The clay, fine silt and fine dust content shall be reported to the nearest 0.1 percent.

#### **4. DETERMINATION OF LIGHT-WEIGHT PIECES ( COAL AND LIGNITE )**

**4.1 Object** — This method of test covers the procedure for determination of approximate percentage of light-weight pieces in aggregate by means of sink-float separation in a heavy liquid of suitable specific gravity.

**4.2 Apparatus** — The apparatus shall consist of the following:

- a) *Balances* — For weighing fine aggregates, a balance having a capacity of not less than 500 g, sensitive to at least 0.1 g; for weighing coarse aggregates, a balance having a capacity of not less than 5 000 g, sensitive to at least 1 g.
- b) *Containers* — Containers suitable for drying the aggregate sample, and containers suitable for holding the heavy liquid during the sink-float separation.
- c) *Skimmer* — A piece of 300-micron sieve cloth of suitable size and shape for separating the floating pieces from the heavy liquid.
- d) *Hot-Plate or Oven.*

#### **4.3 Heavy Liquid**

**4.3.1** The heavy liquid shall consist of a mixture of carbon tetrachloride, and 1, 1, 2, 2-tetrabromoethane, bromoform, and monobromobenzene, or bromoform and benzene ( *see Note 1* ), in such proportions that the desired specific gravity will be obtained ( *see Note 2* ). Bromotrichloromethane may be used as a heavy liquid having a specific gravity of 2.00. The specific gravity shall be maintained within  $\pm 0.01$  of the specified value at all times during the test.

**NOTE 1** — Recovery of the bromoform in the bromoform-benzene mixture can be effected by running a stream of water through the mixture until all benzene has been dissolved and removed.

**NOTE 2** — *Caution* : The chemicals listed in 4.3.1 are highly toxic, both by absorption through the skin and by inhalation. They shall be used only in a hood, and care shall be taken to avoid contact with the skin or inhalation of the fumes.

4.3.2 The approximate volumes of materials to be combined to produce a mixture of the desired specific gravity may be computed from the following specific gravities of the different liquids:

<i>Liquid</i>	<i>Specific Gravity</i>
1,1,2,2-tetrabromoethane	2.97
Benzene	0.88
Bromoform	2.88
Carbon tetrachloride	1.58
Monobromobenzene	1.49

4.3.2.1 For determining coal and lignite, the heavy liquid used shall have a specific gravity of  $2.00 \pm 0.01$ .

4.4 Sample — The minimum size of test sample shall be as follows:

<i>Maximum Size of Aggregate</i>	<i>Minimum Weight of Sample</i>
mm	g
6.3 ( fine aggregate )	200
20	3 000
40	5 000
80	10 000

## 4.5 Procedure

4.5.1 *Fine Aggregate* — Allow the dried sample of fine aggregate to cool to room temperature and then sieve over a 300-micron IS Sieve until less than one percent of the retained material passes the sieve in one minute of continuous sieving. Weigh the material coarser than the 300-micron IS Sieve to the nearest 0.1 g; then introduce it into the heavy liquid in a suitable container, the volume of liquid being at least three times the absolute volume of the aggregate. Pour the liquid off into a second container, passing it through the skimmer and taking care that only the floating pieces are poured off with the liquid and that none of the sand is decanted onto the skimmer. Return to the first container the liquid that has been collected in the second container and, after further agitation of the sample by stirring, repeat the decanting process just described until the sample is free of floating pieces. Wash the decanted pieces contained on the skimmer in carbon tetrachloride, until the heavy liquid is removed, and then dry. The pieces will dry very quickly, but may be placed in an oven at 105°C for a few minutes if desired. Brush the dry decanted

pieces from the skimmer onto the balance pan and determine the weight to the nearest 0.1 g.

**4.5.2 Coarse Aggregate** — Allow the dried sample of coarse aggregate to cool to room temperature and sieve over a 4.75-mm IS Sieve. Weigh the material coarser than the 4.75-mm IS Sieve to the nearest 1 g; then introduce it into the heavy liquid in a suitable container, the volume of liquid being at least three times the absolute volume of the aggregate. Using the skimmer, remove the pieces that rise to the surface, and save them. Repeatedly agitate the remaining pieces and remove the floating pieces until no additional pieces rise to the surface. Wash the decanted pieces in carbon tetrachloride until all of the heavy liquid is removed, and allow to dry. Determine the weight of the decanted pieces to the nearest one gram.

**NOTE**—Materials, brownish black or black shall be considered as coal and lignite and shall be collected and weighed.

**4.6 Calculation** — Calculate the percentage of light-weight pieces (pieces floating on the heavy liquid) as follows:

For fine aggregate:

$$L = \frac{W_1}{W_2} \times 100$$

For coarse aggregate:

$$L = \frac{W_1}{W_3} \times 100$$

where

$L$  = percentage of light-weight pieces;

$W_1$  = dry weight in g, of decanted pieces;

$W_2$  = dry weight in g, of portion of sample coarser than 300-micron IS Sieve; and

$W_3$  = dry weight in g, of portion of sample coarser than 4.75-mm IS Sieve.

**4.7 Reporting of Results**—The percentage of light-weight pieces (coal and lignite) in the aggregate shall be reported to the nearest 0.1 percent.

## 5. DETERMINATION OF SOFT PARTICLES

**5.1 Object** — This method of test deals with the procedure of determining the quantity of soft particles in coarse aggregates on the basis of scratch-hardness.

**NOTE** — This method is intended to be used to identify materials that are soft, including those which are so poorly bonded that the separate particles in the piece are easily detached from the mass. The test is not intended to identify other types of deleterious materials in aggregates.

**5.2 Apparatus** — The apparatus shall consist of a brass rod, having a Rockwell hardness of 65 *RHB* to 75 *RHB*.

**5.2.1** A brass rod of about 1.6 mm diameter and of proper hardness inserted into the wood shaft of an ordinary lead pencil is a convenient tool for field or laboratory use.

### 5.3 Sample

**5.3.1** Aggregates for the test shall consist of material from which the sizes finer than the 10-mm IS Sieve have been removed. The sample tested shall be of such size that it will yield not less than the following amounts of the different sizes, which shall be available in amounts of 10 percent or more:

Sieve Size ( Square Opening Sieves )	Sample Weight
mm	g
Over 10 to 12.5	200
" 12.5 " 20	600
" 20 " 25	1 500
" 25 " 40	4 500
" 40 " 50	12 000

**5.3.2** If the sample contains less than 10 percent of any of the sizes specified under 5.3.1, the size shall not be tested but, for the purpose of calculating the test results, it shall be considered to contain the same percentage of the soft particles as the average of the next smaller and the next larger size, or, if one of these sizes is absent, it shall be considered to have the same percentage of soft particles as the next larger or next smaller size, whichever is present.

**5.4 Procedure** — Each particle of aggregate under test shall be scratched with the brass rod described in 5.2 using only a small amount ( about 1 kg ) of pressure. Particles are considered to be soft if during the scratching process, a groove is made in them without deposition of metal from the brass rod or if separate particles are detached from the rock mass.

**NOTE** — In the case of some sandstones, brass fragments may be deposited on hard individual grains while at the same time separate particles are detached from the mass due to a weak binding medium. Such particles are to be considered as soft.

**5.5 Calculation and Report** — The report shall include the following information:

- a) Weight and number of particles of each size of each sample tested with the brass rod;
- b) Weight and number of particles of each size of each sample classified as soft in the test;
- c) Percentage of test sample classified as soft by weight and by number of particles; and
- d) Weighed average percentage of soft particles calculated from percentage in item (c) and based on the grading of sample of aggregate received for examination or, preferably, on the average grading of the material from that portion of the supply of which the sample is representative. In these calculations, sizes finer than the 10-mm IS Sieve shall not be included.

## 6. ESTIMATION OF ORGANIC IMPURITIES

**6.1 Object** — This method of test covers an approximate method of estimating whether organic compounds are present in natural sand in sufficient quantities to be harmful, and hence intended to show whether further tests are necessary or desirable.

**NOTE** — Harmless organic materials may cause colouration and certain naturally occurring organic compounds do not cause colouration.

### 6.2 Procedure

**6.2.1** The sand shall be tested as delivered and without drying. A 350-ml graduated clear glass medicine bottle shall be filled to the 75-ml mark with 3 percent solution of sodium hydroxide in water. The sand shall be added gradually until the volume measured by the sand

layer is 125 ml. The volume shall then be made up to 200 ml by adding more solution. The bottle shall be stoppered and shaken vigorously and then allowed to stand for 24 hours.

**6.2.2** Other tests shall be made if the colour of the liquid above the sand is darker than a standard solution freshly prepared as follows:

Add 2.5 ml of 2 percent solution of tannic acid in 10 percent alcohol, to 97.5 ml of a 3 percent sodium hydroxide solution. Place in a 350-ml bottle, stopper, shake vigorously and allow to stand for 24 hours before comparison with the solution above the sand. Alternatively, an instrument or coloured acetate sheets for making the comparison can be obtained, but it is desirable that these should be verified on receipt by comparison with the standard solution.



## BUREAU OF INDIAN STANDARDS

### Headquarters:

Manak Bhavan, 9 Bahadur Shah Zafar Marg, NEW DELHI 110002

Telephones: 323 0131, 323 3375, 323 9402

Fax : 91 11 3234062, 91 11 3239399, 91 11 3239382

Telegrams : Manaksans

(Common to all Office

Telepho

### Central Laboratory :

Plot No. 20/9, Site IV, Sahibabad Industrial Area, Sahibabad 201010

8-77 00

### Regional Offices:

Central : Manak Bhavan, 9 Bahadur Shah Zafar Marg, NEW DELHI 110002 323 76

\*Eastern : 1/14 CIT Scheme VII M, V.I.P. Road, Maniktola, CALCUTTA 700054 337 86

Northern : SCO 335-336, Sector 34-A, CHANDIGARH 160022 60 38 4

Southern : C.I.T. Campus, IV Cross Road, CHENNAI 600113 235 23

†Western : Manakalaya, E9, Behind Marol Telephone Exchange, Andheri (East), 832 92  
MUMBAI 400093

### Branch Offices::

'Pushpak', Nurmohamed Shaikh Marg, Khanpur, AHMEDABAD 380001 550 13

‡Peenya Industrial Area, 1st Stage, Bangalore-Turnkur Road, 839 49  
BANGALORE 560058

Gangotri Complex, 5th Floor, Bhadbhada Road, T.T. Nagar, BHOPAL 462003 55 40 2

Plot No. 62-63, Unit VI, Ganga Nagar, BHUBANESHWAR 751001 40 36 2

Kalaikathir Buildings, 670 Avinashi Road, COIMBATORE 641037 21 01 4

Plot No. 43, Sector 16 A, Mathura Road, FARIDABAD 121001 8-28 88

Savitri Complex, 116 G.T. Road, GHAZIABAD 201001 8-71 19

53/5 Ward No.29, R.G. Barua Road, 5th By-lane, GUWAHATI 781003 54 11 3

5-8-56C, L.N. Gupta Marg, Nampally Station Road, HYDERABAD 500001 20 10 8

E-52, Chitaranjan Marg, C- Scheme, JAIPUR 302001 37 29 2

117/418 B, Sarvodaya Nagar, KANPUR 208005 21 68 7

Seth Bhawan, 2nd Floor, Behind Leela Cinema, Naval Kishore Road, 23 89 2  
LUCKNOW 226001

NIT Building, Second Floor, Gokulpat Market, NAGPUR 440010 52 51 7

Patliputra Industrial Estate, PATNA 800013 26 23 0

Institution of Engineers (India) Building 1332 Shivaji Nagar, PUNE 411005 32 36 3

T.C. No. 14/1421, University P. O. Palayam, THIRUVANANTHAPURAM 695034 6 21 17

\*Sales Office is at 5 Chowringhee Approach, P.O. Princep Street, 27 10 8  
CALCUTTA 700072

†Sales Office is at Novelty Chambers, Grant Road, MUMBAI 400007 309 65 2

‡Sales Office is at 'F' Block, Unity Building, Narashimaraja Square, 222 39 7  
BANGALORE 560002

TO

IS:2386(Part II)-1963 METHODS OF TEST FOR  
AGGREGATES FOR CONCRETE

PART II ESTIMATION OF DELETERIOUS MATERIALS  
AND ORGANIC IMPURITIES

Alteration

(Page 14, clause 6.1) - Substitute the following  
for the existing clause:

"6.1 Object - This method of test covers an approxi-  
mate method of estimating whether organic compounds  
are present in natural sand in sufficient quantities  
to be harmful, and hence is intended to show whether  
further tests are necessary or desirable.

NOTE 1 - The test for determination of effect of  
organic impurities on mortar strength is covered by  
IS:2386(Part VI)-1963 'Method of test for aggregates  
for concrete:Part VI Measuring mortar making pro-  
perties of fine aggregates'.

NOTE 2 - Harmless organic materials may cause  
colouration and certain naturally occurring organic  
compounds do not cause colouration.

(BDC 2)