

12 DEC 1995

IS : 1905 - 1987

Indian Standard

(Reaffirmed 1998)

CODE OF PRACTICE FOR
STRUCTURAL USE OF UNREINFORCED
MASONRY

(Third Revision)

First Reprint NOVEMBER 1995

UDC 624-046-5 : 692-231-2/3 : 006-76

© Copyright 1989

BUREAU OF INDIAN STANDARDS
MANAK BHAVAN, 9 BAHADUR SHAH ZAFAR MARG
NEW DELHI 110002

Indian Standard

CODE OF PRACTICE FOR STRUCTURAL USE OF UNREINFORCED MASONRY

(Third Revision)

0. FOREWORD

0.1 This Indian Standard (Third Revision) was adopted by the Bureau of Indian Standards on 30 August 1987, after the draft finalized by the Structural Safety Sectional Committee had been approved by the Civil Engineering Division Council.

0.2 Structural adequacy of masonry walls depends upon a number of factors, among which mention may be made of quality and strength of masonry units and mortars, workmanship, methods of bonding, unsupported height of walls, eccentricity in the loading, position and size of openings in walls, location of cross walls and the combination of various external loads to which walls are subjected.

0.3 This code was first published in 1961. In its revision in 1969, basic compressive stresses and stress factors for slenderness were modified resulting in increased permissible stresses in load bearing brick and block walls. The second revision was published in 1980. The following major changes were made in its second revision:

- a) Use of stones (in regular sized units), concrete blocks, lime based blocks and hollow blocks were included as masonry units;
- b) Mix proportions and compressive strengths of mortars used in masonry were revised;
- c) Optimum mortar mixes for maximum strength of masonry for units of various strengths were indicated;
- d) Provisions for lateral supports to walls had been amplified so as to include stability requirements;
- e) Conditions of support for calculation of effective height of masonry walls and columns, and effective length of masonry walls were spelt out more clearly;
- f) Maximum allowable slenderness ratio for load bearing walls was increased;
- g) In case of free-standing walls, height to thickness ratios were indicated for different

wind pressures, based upon requirements for stability;

- h) Basic compressive stresses for masonry members were modified so that strength of masonry units correspond to revised values of brick crushing strength specified in IS : 1077-1986*;
- j) Formula for calculating area reduction factor was modified;
- k) Angle of dispersion of concentrated loads, from the direction of such loads was changed from 45 to 30*;
- m) Provisions relating to shape modification factors for masonry units other than common bricks were amplified;
- n) Values of permissible shear stress was related to the actual compressive stresses in masonry due to dead loads; and
- p) Provisions on 'corbelling' were amplified.

0.4 The present revision is intended to further modify certain provisions as a result of experience gained with the use of the second revision of the standard. The following major changes have been made in this revision:

- a) The requirements of a masonry element for stability have been modified.
- b) In the design of a free standing wall, provision has been made for taking advantage of the tensile resistance in masonry under certain conditions.
- c) Provision regarding effective height of a masonry wall between openings has been modified.
- d) Method of working out effective height of a wall with a membrane type DPC has been modified.
- e) Criteria for working out effective length of wall having openings has been modified.

*Specification for common burnt clay building bricks (fourth revision).

- f) Some general guidelines have been given for dealing with concentrated loads for design of walls.
- g) Provisions regarding cutting and chases in walls have been amplified.
- h) The title of the standard has been changed for the sake of greater clarity.

0.5 The Sectional Committee responsible for preparation of this standard has taken into consideration views of all who are interested in this field and has related the standard to the prevailing practices in the country. Due weightage has also been given to the need for international coordination among the standards and practices prevailing in different countries of the world. In the preparation of this code, assistance has been derived from the following publications:

- a) AS 1640-1974 — SAA Brickwork Code. Standards Association of Australia.
- b) National Building Code of Canada, 1977. National Research Council of Canada.
- c) DIN 1053/1 Code on brick calculation and performance. Deutsches Institut für Normung.
- d) CP 111 : Part 2 : 1970 Structural recommendations for load bearing walls with

amendments up to 1976. British Standards Institution.

- e) BS 5628 : Part 1 : 1978 Code of practice for structural use of masonry, Part 1 Unreinforced masonry. British Standards Institution.
- f) CP 121 : Part 1 : 1973 Code of practice for walling, Part 1 Brick and block masonry. British Standards Institution.
- g) Recommended practice for engineered brick masonry. Brick Institute of America, 1969.

0.6 It is assumed in this code that design of masonry work is done by qualified engineer and that execution is carried out (according to the recommendations of this code read with other relevant codes) under the directions of an experienced supervisor.

0.7 For the purpose of deciding whether a particular requirement of this standard is complied with, the final value, observed or calculated, expressing the result of a test or analysis, shall be rounded off in accordance with IS : 2-1960*. The number of significant places retained in the rounded off value should be the same as that of the specified value in this standard.

*Rules for rounding off numerical values (revised).

1. SCOPE

1.1 This code gives recommendations for structural design aspect of unreinforced load bearing and non-load bearing walls, constructed with solid or perforated burnt clay bricks, sand-lime bricks, stones, concrete blocks, lime based blocks or burnt clay hollow blocks in regard to the materials to be used, maximum permissible stresses and the methods of design.

1.2 The recommendations of the code do not apply to walls constructed in mud mortars.

2. TERMINOLOGY

2.0 For the purpose of this code, the definitions given in IS : 2212-1962* and the following shall apply.

2.1 **Bed Block** — A block bedded on a wall, column or pier to disperse a concentrated load on a masonry element.

2.2 **Bond** — Arrangement of masonry units in successive courses to tie the masonry together both longitudinally and transversely; the arrangement is usually worked out to ensure that no vertical joint of one course is exactly over the one in the next course above or below it, and there is maximum possible amount of lap.

2.3 Column, Pier and Buttress

2.3.1 **Column** — An isolated vertical load bearing member, width of which does not exceed four times the thickness.

2.3.2 **Pier** — A thickened section forming integral part of a wall placed at intervals along the wall, to increase the stiffness of the wall or to carry a vertical concentrated load. Thickness of a pier is the overall thickness including the thickness of the wall or when bonded into a leaf of a cavity wall, the thickness obtained by treating that leaf as an independent wall (see Fig. 1).

2.3.3 **Buttress** — A pier of masonry built as an integral part of wall and projecting from either or both surfaces, decreasing in cross-sectional area from base to top.

2.4 **Cross-Sectional Area of Masonry Unit** — Net cross-sectional area of a masonry unit shall be taken as the gross cross-sectional area minus the area of cellular space. Gross cross-sectional area of cored units shall be determined to the outside of the coring but cross-sectional area of grooves shall not be deducted from the gross cross-sectional area to obtain the net cross-sectional area.

2.5 **Curtain Wall** — A non-load bearing wall subject to lateral loads. It may be laterally

*Code of practice for brickwork.

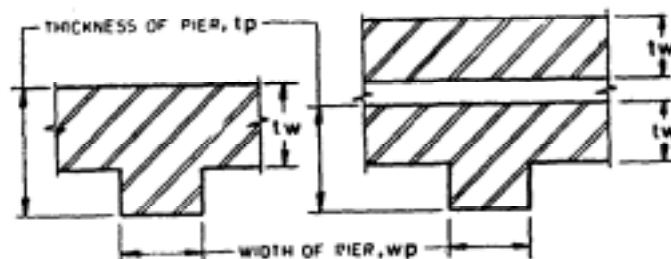

FIG. 1 DEFINITION OF PIER

supported by vertical or horizontal structural members, where necessary (see Fig. 2).

2.6 Effective Height — The height of a wall or column to be considered for calculating slenderness ratio.

2.7 Effective Length — The length of a wall to be considered for calculating slenderness ratio.

2.8 Effective Thickness — The thickness of a wall or column to be considered for calculating slenderness ratio.

2.9 Hollow Unit — A masonry unit of which net cross-sectional area in any plane parallel to the bearing surface is less than 75 percent of its gross cross-sectional area measured in the same plane (see 2.4 and 2.16).

2.10 Grout — Mortar of pourable consistency.

2.11 Joint — A junction of masonry units.

2.11.1 Bed Joint — A horizontal mortar joint upon which masonry units are laid.

2.11.2 Cross Joint — A vertical joint, normal to the face of the wall.

2.11.3 Wall Joint — A vertical joint parallel to the face of the wall.

2.12 Leaf — Inner or outer section of a cavity wall.

2.13 Lateral Support — A support which enables a masonry element to resist lateral load and/or restrains lateral deflection of a masonry element at the point of support.

2.14 Load Bearing Wall — A wall designed to carry an imposed vertical load in addition to its own weight, together with any lateral load.

2.15 Masonry — An assemblage of masonry units properly bonded together with mortar.

2.16 Masonry Unit — Individual units which are bonded together with the help of mortar to form a masonry element, such as wall, column, pier and buttress.

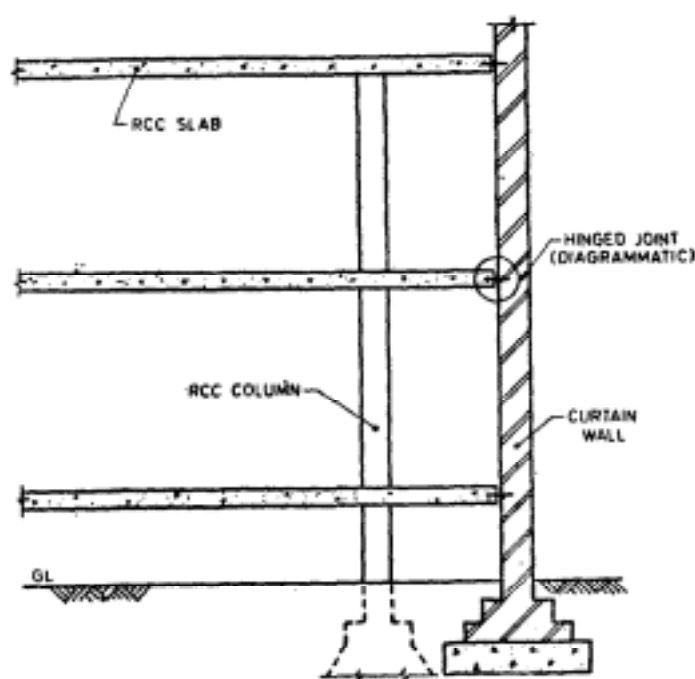

FIG. 2 MASONRY CURTAIN WALL

2.17 Partition Wall — An interior non-load bearing wall, one storey or part storey in height.

2.18 Panel Wall — An exterior non-load bearing wall in framed construction, wholly supported at each storey but subjected to lateral loads.

2.19 Shear Wall — A wall designed to carry horizontal forces acting in its plane with or without vertical imposed loads.

2.20 Slenderness Ratio — Ratio of effective height or effective length to effective thickness of a masonry element.

2.21 Types of Walls

2.21.1 Cavity Wall — A wall comprising two leaves, each leaf being built of masonry units and separated by a cavity and tied together with metal ties or bonding units to ensure that the two leaves act as one structural unit, the space between the leaves being either left as continuous cavity or filled with a non-load bearing insulating and waterproofing material.

2.21.2 Faced Wall — A wall in which facing and backing of two different materials are bonded together to ensure common action under load (see Fig. 3).

NOTE—To ensure monolithic action in faced walls, shear strength between the facing and the

backing shall be provided by toothing, bonding or other means.

2.21.3 Veneered Wall — A wall in which the facing is attached to the backing but not so bonded as to result in a common action under load.

3. MATERIALS

3.1 Masonry Units — Masonry units used in construction shall comply with the following standards:

Burnt clay building bricks	IS : 1077-1986* or IS : 2180-1985† or IS : 2222-1979‡
Stones (in regular sized units)	IS : 3316-1974§ or IS : 3620-1979¶
Sand lime bricks	IS : 4139-1976¶

*Specification for common burnt clay building bricks (fourth revision).

†Specification for heavy-duty burnt clay building bricks (second revision).

‡Specification for burnt clay perforated building bricks (second revision).

§Specification for structural granite (first revision).

¶Specification for laterite stone block for masonry (first revision).

¶Specification for sandlime bricks (first revision).

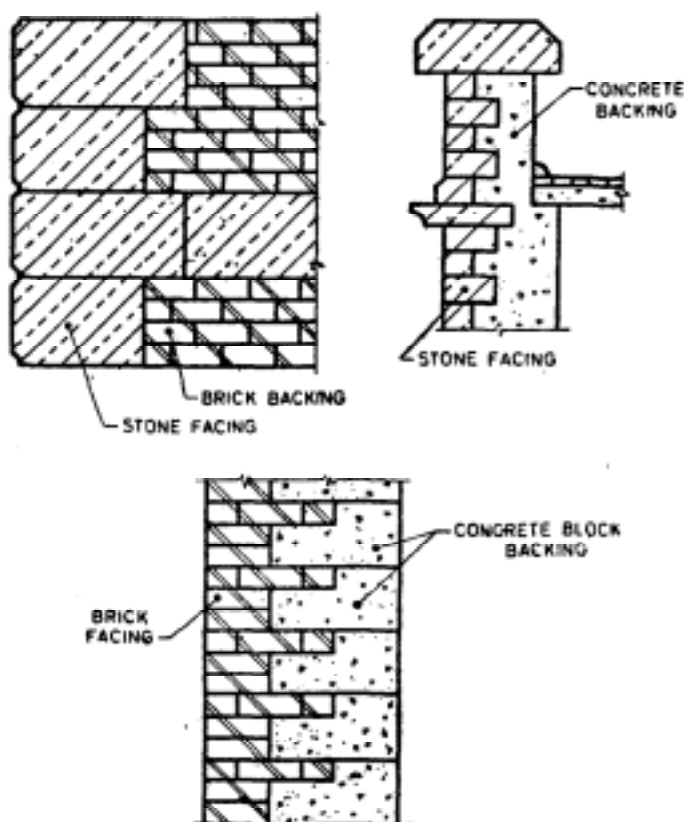

FIG. 3 TYPICAL FACED WALL

Concrete blocks (solid and hollow)	IS : 2185 (Part 1)-1979* or IS : 2185 (Part 2)-1983†
Lime based blocks	IS : 3115-1978‡
Burnt clay hollow blocks	IS : 3952-1978§
Gypsum partition blocks	IS : 2849-1983
Autoclaved cellular concrete blocks	IS : 2185 (Part 3)-1984¶

NOTE 1 — Gypsum partition blocks are used only for construction of non-load bearing partition walls.

NOTE 2 — Use of other masonry units, such as precast stone blocks, not covered by the above specifications, can also be permitted based on test results.

3.1.1 Masonry units that have been previously used shall not be reused in brickwork or blockwork construction, unless they have been thoroughly cleaned and conform to the code for similar new masonry units.

3.2 Mortar — Mortar for masonry shall comply with the requirements of IS : 2250-1981**.

3.2.1 Mix proportions and compressive strengths of some of the commonly used mortars are given in Table 1.

4. DESIGN CONSIDERATIONS

4.1 General — Masonry structures gain stability from the support offered by cross walls, floors, roof and other elements such as piers and buttresses. Load bearing walls are structurally more efficient when the load is uniformly distributed and the structure is so planned that eccentricity of loading on the members is as small as possible. Avoidance of eccentric loading by providing adequate bearing of floor/roof on the walls providing adequate stiffness in slabs and avoiding fixity at the supports, etc, is especially important in load bearing walls in multistorey structures. These matters should receive careful consideration during the planning stage of masonry structures.

*Specification for concrete masonry units: Part 1 Hollow and solid concrete blocks (second revision).

†Specification for concrete masonry units: Part 2 Hollow and solid lightweight concrete blocks (first revision).

‡Specification for lime based blocks (first revision).

§Specification for burnt clay hollow blocks for walls and partitions (first revision).

||Specification for non-load bearing gypsum partition blocks (solid and hollow types) (first revision).

¶Specification for concrete masonry units: Part 3 Autoclaved cellular (aerated) concrete blocks (first revision).

**Code of practice for preparation and use of masonry mortars (first revision).

4.2 Lateral Supports and Stability

4.2.1 Lateral Supports — Lateral supports for a masonry element such as load bearing wall or column are intended to:

- a) limit slenderness of a masonry element so as to prevent or reduce possibility of buckling of the member due to vertical loads; and
- b) resist horizontal components of forces so as to ensure stability of a structure against overturning.

4.2.1.1 Lateral support may be in the vertical or horizontal direction, the former consisting of floor/roof bearing on the wall or properly anchored to the same and latter consisting of cross walls, piers or buttresses.

4.2.1.2 Requirements of 4.2.1 (a) from consideration of slenderness may be deemed to have been met with if:

- a) In case of a wall, where slenderness ratio is based on effective height, any of the following constructions are provided:
 - 1) RCC floor/roof slab (or beams and slab), irrespective of the direction of span, bears on the supported wall as well as cross walls to the extent of at least 9 cm;
 - 2) RCC floor/roof slab not bearing on the supported wall or cross wall is anchored to it with non-corrodible metal ties of 60 cm length and of section not less than 6 × 30 mm, and at intervals not exceeding 2 m as shown in Fig. 4; and
 - 3) Timber floor/roof, anchored by non-corrodible metal ties of length 60 cm and of minimum section 6 × 30 mm, securely fastened to joists and built into walls as shown in Fig. 5 and 6. The anchors shall be provided in the direction of span of timber joists as well as in its perpendicular direction, at intervals of not more than 2 m in buildings up to two storeys and 1.25 m for buildings more than two storeys in height;

NOTE 1 — In case, precast RCC units are used for floors and roofs, it is necessary to interconnect them and suitably anchor them to the cross walls so that they can transfer lateral forces to the cross-walls.

NOTE 2 — In case of small houses of conventional designs, not exceeding two storeys in height, stiffening effect of partitions and cross walls is such that metal anchors are normally not necessary in case of timber floor/roof and precast RCC floor/roof units.

- b) In case of a wall, when slenderness ratio is based on its effective length; a cross

TABLE 1 MIX PROPORTION AND STRENGTH OF MORTARS FOR MASONRY

(Clause 3.2.1)

Sl. No.	GRADE OF MORTAR	MIX PROPORTIONS (By Loose Volume)					MINIMUM COMPRESSIVE STRENGTH AT 28 DAYS IN N/mm ²
		Cement	Lime	Lime Pozzolana Mixture	Pozzolana	Sand	
(1)	(2)	(3)	(4)	(5)	(6)	(7)	(8)
1	H1	1	½ C or B	0	0	3	10
2(a)	H2	1	½ C or B	0	0	4	7.5
2(b)		1	½ C or B	0	0	4½	6.0
3(a)	M1	1	1 C or B	0	0	5	5.0
3(b)		1		0	0	6	3.0
3(c)		0		1 (LP-40)	0	1½	3.0
4(a)	M2	1	0	0	0	6	3.0
4(b)		1	2 B	0	0	9	2.0
4(c)		0	1 A	0	0	2	2.0
4(d)		0	1 B	0	1	1	2.0
4(e)		0	1 C or B	0	2	0	2.0
4(f)		0	0	1 (LP-40)	0	1½	2.0
5(a)	M3	1	0	0	0	7	1.5
5(b)		1	3 B	0	0	12	1.5
5(c)		0	1 A	0	0	3	1.5
5(d)		0	1 B	0	2	1	1.5
5(e)		0	1 C or B	0	3	0	1.5
5(f)		0	0	1 (LP-40)	0	2	1.5
6(a)	L1	1	0	0	0	8	0.7
6(b)		0	1 B	0	1	2	0.7
6(c)		0	1 C or B	0	2	1	0.7
6(d)		0	0	1 (LP-40)	0	2½	0.7
6(e)		0	0	1 (LP-20)	0	1½	0.7
7(a)	L2	0	1 B	0	0	3	0.5
7(b)		0	1 C or B	0	1	2	0.5
7(c)		0	0	1 (LP-7)	0	1½	0.5

NOTE 1 — Sand for making mortar should be well graded. In case sand is not well graded, its proportion shall be reduced in order to achieve the minimum specified strength.

NOTE 2 — For mixes in Sl No. 1 and 2, use of lime is not essential from consideration of strength as it does not result in increase in strength. However, its use is highly recommended since it improves workability.

NOTE 3 — For mixes in Sl No. 3(a), 4(a), 5(a) and 6(a), either lime C or B to the extent of 1/4 part of cement (by volume) or some plasticizer should be added for improving workability.

NOTE 4 — For mixes in Sl No. 4(b) and 5(b), lime and sand should first be ground in mortar mill and then cement added to coarse stuff.

NOTE 5 — It is essential that mixes in Sl No. 4(c), 4(d), 4(e), 5(d), 5(e), 6(b), 6(c), 7(a) and 7(b) are prepared by grinding in a mortar mill.

NOTE 6 — Mix in Sl No. 2(b) has been classified to be of same grade as that of Sl No. 2(a), mixes in Sl No. 3(b) and 3(c) same as that in Sl No. 3(a) and mixes in Sl No. 4(b) to 4(f) same as that in Sl No. 4(a), even though their compressive strength is less. This is from consideration of strength of masonry using different mix proportions.

NOTE 7 — A, B and C denote eminently hydraulic lime, semi-hydraulic lime and fat lime respectively as specified in relevant Indian Standards.

wall/pier/buttress of thickness equal to or more than half the thickness of the supported wall or 90 mm, whichever is more, and length equal to or more than one-fifth of the height of wall is built at right angle to the wall (see Fig. 7) and bonded to it according to provision of 4.2.2.2 (d);

c) in case of a column, an RCC or timber beam/R S joist/roof truss is supported on the column. In this case, the column will not be deemed to be laterally supported in the direction right angle to it; and

d) in case of a column, an RCC beam forming a part of beam and slab construction is supported on the column, and slab adequately bears on stiffening walls. This construction will provide lateral support to the column in the direction of both horizontal axes.

4.2.2 Stability — A wall or column subjected to vertical and lateral loads may be considered to be provided with adequate lateral support from consideration of stability, if the construction

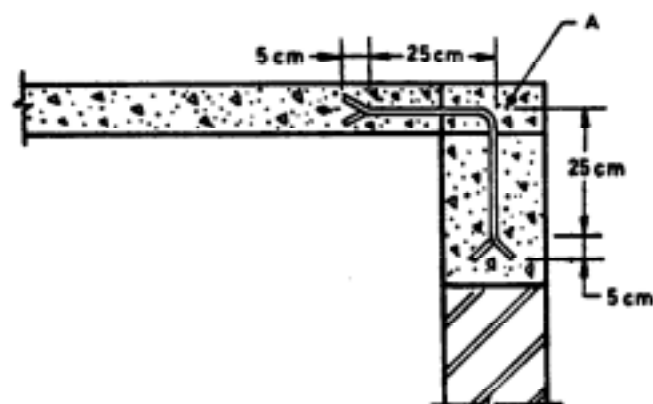
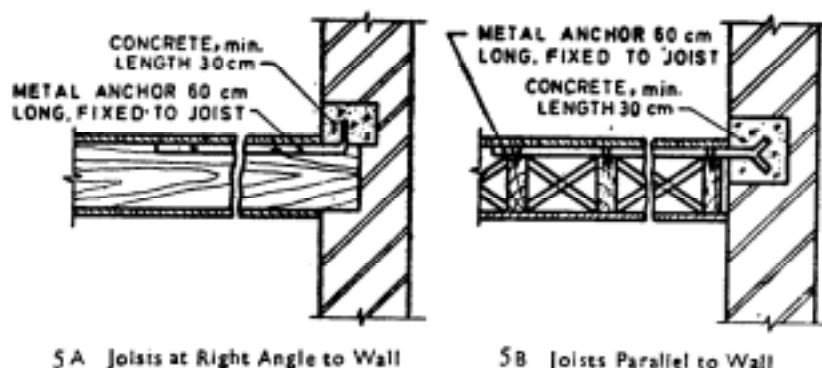

FIG. 4 ANCHORING OF RCC SLAB WITH MASONRY WALL

(WHEN SLAB DOES NOT BEAR ON WALL)



5A Joists at Right Angle to Wall

5B Joists Parallel to Wall

FIG. 5 TYPICAL DETAILS FOR ANCHORAGE OF SOLID WALLS

providing the support is capable of resisting the following forces:

- Simple static reactions at the point of lateral support to all the lateral loads; plus
- 2.5 percent of the total vertical load that the wall or column is designed to carry at the point of lateral support.

4.2.2.1 For the purpose specified in 4.2.2, if the lateral supports are in the vertical direction, these should meet the requirements given in 4.2.1.2 (a) and should also be capable of acting as horizontal girders duly anchored to the cross wall so as to transmit the lateral loads to the foundations without exceeding the permissible stresses in the cross walls.

4.2.2.2 In case of load bearing buildings up to four storeys, stability requirements of 4.2.2 may be deemed to have been met with if:

- height to width ratio of building does not exceed 2;

- cross walls acting as stiffening walls continuous from outer wall to outer wall or outer wall to a load bearing inner wall, and of thickness and spacings as given in Table 2 are provided. If stiffening wall or walls that are in a line, are interrupted by openings, length of solid wall or walls in the zone of the wall that is to be stiffened shall be at least one-fifth of height of the opening as shown in Fig. 8;
- floors and roof either bear on cross walls or are anchored to those walls as in 4.2.1.2 such that all lateral loads are safely transmitted to those walls and through them to the foundation; and
- cross walls are built jointly with the bearing walls and are jointly mortared, or the two interconnected by tothing. Alternatively, cross walls may be anchored to walls

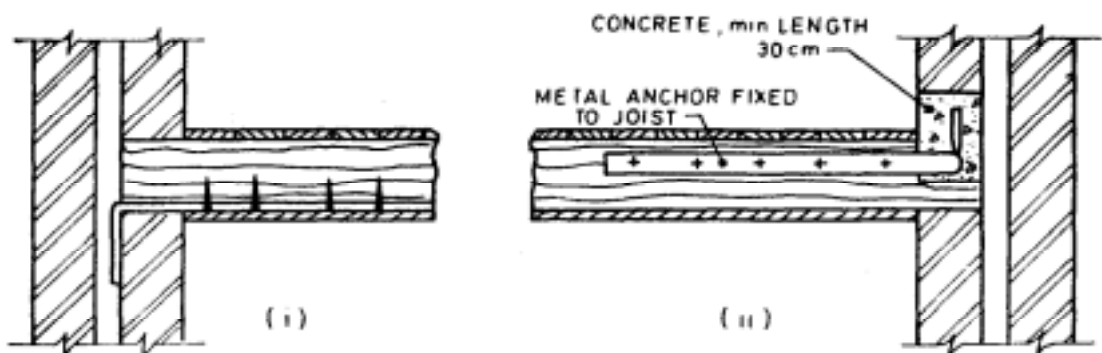

6A Timber Joists at Right Angles to Wall

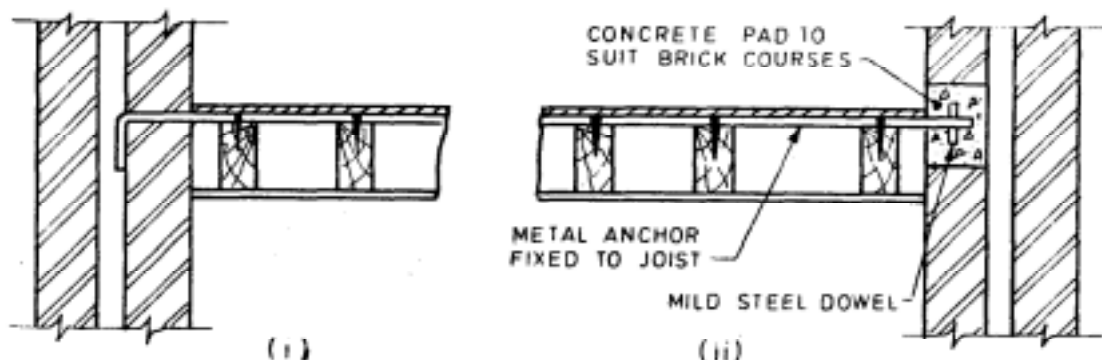

6B Timber Joists Parallel to Wall

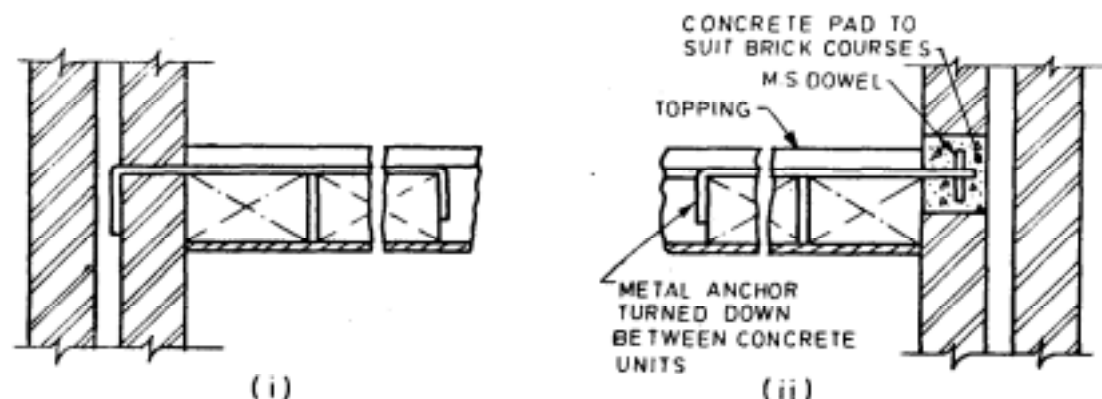

6C Precast Concrete Floor Units Parallel to Wall

FIG. 6 TYPICAL DETAILS FOR ANCHORAGE OF CAVITY WALLS

to be supported by ties of non-corrodible metal of minimum section 6×35 mm and length 60 cm with ends bent up at least 5 cm; maximum vertical spacing of ties being 1.2 m (see Fig. 9).

4.2.2.3 In case of halls exceeding 8.0 m in length, safety and adequacy of lateral supports shall always be checked by structural analysis.

4.2.2.4 A trussed roofing may not provide lateral support, unless special measures are adopted to brace and anchor the roofing. However, in case of residential and similar buildings of conventional design with trussed roofing having cross walls, it may be assumed that stability requirements are met with by the cross walls and structural analysis for stability may be dispensed with.

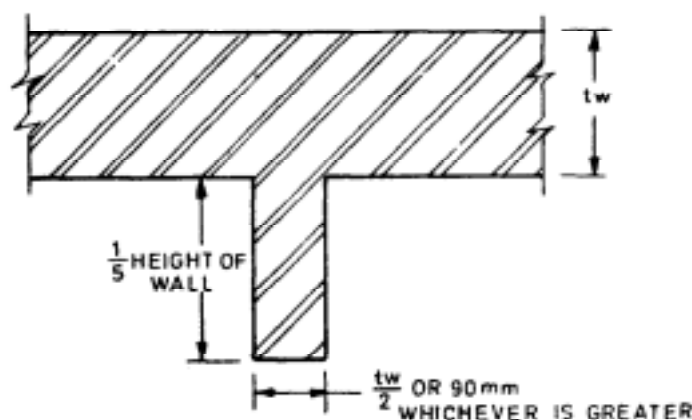

FIG. 7 MINIMUM DIMENSIONS FOR MASONRY WALL OR BUTTRESS PROVIDING EFFECTIVE LATERAL SUPPORT

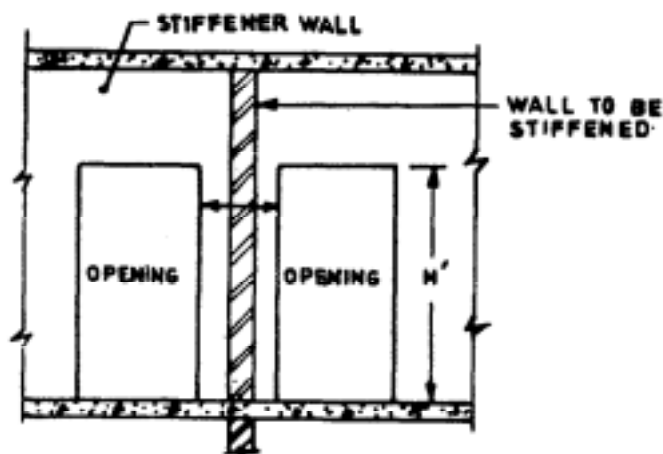

FIG. 8 OPENING IN STIFFENING WALL

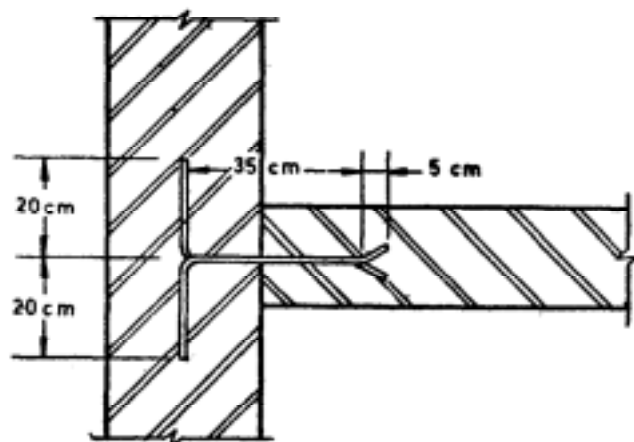

FIG. 9 ANCHORING OF STIFFENING WALL WITH SUPPORTED WALL

4.2.2.5 Capacity of a cross wall, also called shear wall, sometimes to take horizontal loads and consequent bending moments, increases when parts of bearing walls act as flanges to the cross

wall. Maximum overhanging length of bearing wall which could effectively function as a flange should be taken as $12t$ or $H/6$, whichever is less, in case of T/I shaped walls and $6t$ or $H/16$,

TABLE 2 THICKNESS AND SPACING OF STIFFENING WALLS

[Clause 4.2.2.2 (b)]

Sl. No.	THICKNESS OF BEARING WALL TO BE STIFFENED	HEIGHT OF STOREY NOT TO EXCEED	STIFFENING WALL*		
			Thickness not Less Than		Maximum Spacing
			1 to 3 Storeys	4 Storeys	
(1)	(2)	(3)	(4)	(5)	(6)
	cm	m	cm	cm	m
1	10	3.2	10	—	4.5
2	20	3.2	10	20	6.0
3	30	3.4	10	20	8.0
4	Above 30	5.0	10	20	8.0

*Storey height and maximum spacings as given are centre-to-centre dimensions.

whichever is less, in case of *I/U* shaped walls, where t is the thickness of bearing wall and H is the total height of wall above the level being considered as shown in Fig. 10.

4.2.2.6 External walls of basement and plinth —

In case of external walls of basement and plinth stability requirements of 4.2.2 may be deemed to have been met with if:

- bricks used in basement and plinth have a minimum crushing strength of 5 N/mm^2 and mortar used in masonry is of Grade M1 or better;
- clear height of ceiling in basement does not exceed 2.6 m;
- walls are stiffened according to provisions of 4.2.2.1;
- in the zone of action of soil pressure on basement walls, traffic load excluding any surcharge due to adjoining buildings does not exceed 5 kN/m^2 and terrain does not rise; and
- minimum thickness of basement walls is in accordance with Table 3.

NOTE — In case there is surcharge on basement walls from adjoining buildings, thickness of basement walls shall be based on structural analysis.

TABLE 3 MINIMUM THICKNESS OF BASEMENT WALLS

Sl. No.	MINIMUM THICKNESS OF BASEMENT WALL (NOMINAL)	HEIGHT OF THE GROUND ABOVE BASEMENT FLOOR LEVEL WITH WALL LOADING (PERMANENT LOAD)	
		More than 50 kN/m	Less than 50 kN/m
		(3)	(4)
(1)	(2)	(3)	(4)
	cm	m	m
1	40	2.50	2.00
2	30	1.75	1.40

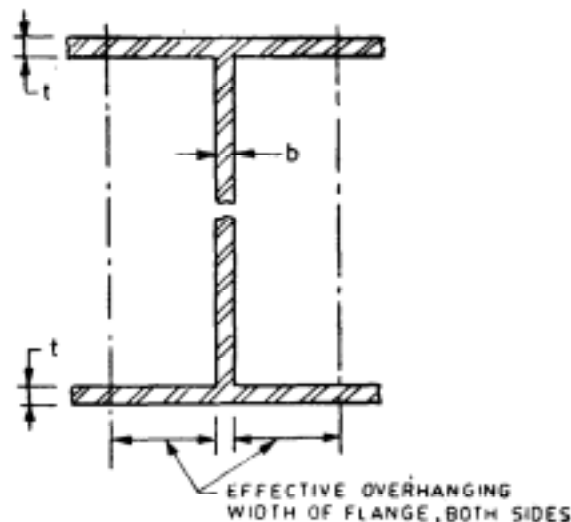

Effective overhanging width of flange = $12t$ or $H/6$ whichever is less, H being the total height of wall above the level being considered.

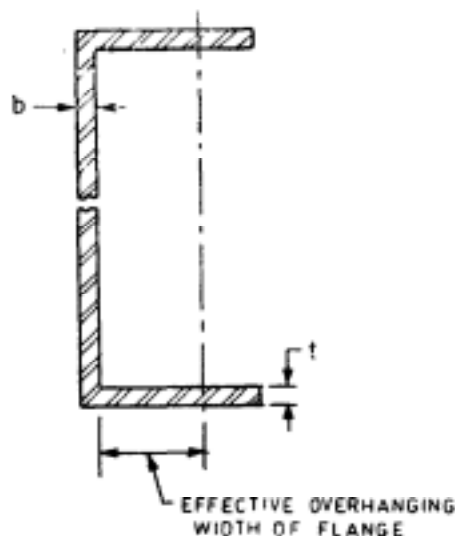

Effective overhanging width of flange = $6t$ or $H/6$ whichever is less, H being the total height of wall above the level being considered.

FIG. 10 EFFECTIVE OVERHANGING WIDTH OF FLANGES FOR

4.2.2.7 Walls mainly subjected to lateral loads

- Free-standing wall** — A free-standing wall such as compound wall or parapet wall is acted upon by wind force which tends to overturn it. This tendency to overturning is resisted by gravity force due to self-weight of wall, and also by flexural moment of resistance on account of tensile strength of masonry. Free-standing walls shall thus be designed as in 5.5.2.1. If mortar used

for masonry can not be relied upon for taking flexural tension (see 5.4.2), stability of free-standing wall shall be ensured such that stability moment of wall due to self-weight equals or exceeds 1.5 times the overturning moment.

- b) *Retaining wall* — Stability for retaining walls shall normally be achieved through gravity action but flexural moment of resistance could also be taken advantage of under special circumstances at the discretion of the designer (see 5.4.2).

4.3 Effective Height

4.3.1 Wall — Effective height of a wall shall be taken as shown in Table 4 (see Fig. 11).

NOTE — A roof truss or beam supported on a column meeting the requirements of 4.2.2.1 is deemed to provide lateral support to the column only in the direction of the beam/truss.

4.3.2 Column — In case of a column, effective height shall be taken as actual height for the direction it is laterally supported and as twice the actual height for the direction it is not laterally supported (see Fig. 12).

NOTE 1 — A roof truss or beam supported on a column meeting the requirements of 4.2.2.1 is deemed to provide lateral support to the column only in the direction of the beam/truss.

NOTE 2 — When floor or roof consisting of RCC beams and slabs is supported on columns, the columns would be deemed to be laterally supported in both directions.

4.3.3 Openings in Walls — When openings occur in a wall such that masonry between the openings is by definition a column, effective height of masonry between the openings shall be reckoned as follows:

- a) When wall has full restraint at the top:
- 1) Effective height for the direction perpendicular to the plane of the wall equals $0.75 H$ plus $0.25 H_1$, where H is the distance between supports and H_1 is the height of the taller opening; and
 - 2) Effective height for the direction parallel to the wall equals H , that is, the distance between the supports.
- b) When wall has partial restraint at the top:
- 1) Effective height for the direction perpendicular to plane of wall equals H when height of neither opening exceeds $0.5 H$ and it is equal to $2 H$ when height of any opening exceeds $0.5 H$; and
 - 2) Effective height for the direction parallel to the plane of the wall equals $2H$.

TABLE 4 EFFECTIVE HEIGHT OF WALLS

(Clause 4.3.1)		
Sl. No.	CONDITION OF SUPPORT	EFFECTIVE HEIGHT
(1)	(2)	(3)
1.	Lateral as well as rotational restraint (that is, full restraint) at top and bottom. For example, when the floor/roof spans on the walls so that reaction to load of floor/roof is provided by the walls, or when an RCC floor/roof has bearing on the wall (minimum 9 cm), irrespective of the direction of the span (foundation footings of a wall give lateral as well as rotational restraint)	$0.75 H$
2.	Lateral as well as rotational restraint (that is, full restraint) at one end and only lateral restraint (that is, partial restraint) at the other. For example, RCC floor/roof at one end spanning or adequately bearing on the wall and timber floor/roof not spanning on wall, but adequately anchored to it, on the other end	$0.85 H$
3.	Lateral restraint, without rotational restraint (that is, partial restraint) on both ends. For example, timber floor/roof, not spanning on the wall but adequately anchored to it on both ends of the wall, that is, top and bottom	$1.00 H$
4.	Lateral restraint as well as rotational restraint (that is, full restraint) at bottom but have no restraint at the top. For example, parapet walls with RCC roof having adequate bearing on the lower wall, or a compound wall with proper foundation on the soil	$1.50 H$

NOTE 1 — H is the height of wall between centres of support in case of RCC slabs and timber floors. In case of footings or foundation block, height (H) is measured from top of footing or foundation block. In case of roof truss, height (H) is measured up to bottom of the tie beam. In case of beam and slab construction, height should be measured from centre of bottom slab to centre of top beam. All these cases are illustrated by means of examples shown in Fig. 11.

NOTE 2 — For working out effective height, it is assumed that concrete DPC, when properly bonded with masonry, does not cause discontinuity in the wall.

NOTE 3 — Where membrane type damp-proof course or termite shield causes a discontinuity in bond, the effective height of wall may be taken to be greater of the two values calculated as follows:

- a) consider H from top of footing ignoring DPC and take effective height as $0.75 H$.
- b) consider H from top of DPC and take effective height as $0.85 H$.

NOTE 4 — When assessing effective height of walls, floors not adequately anchored to walls shall not be considered as providing lateral support to such walls.

NOTE 5 — When thickness of a wall bonded to a pier is at least two-thirds the thickness of the pier measured in the same direction, the wall and pier may be deemed to act as one structural element.

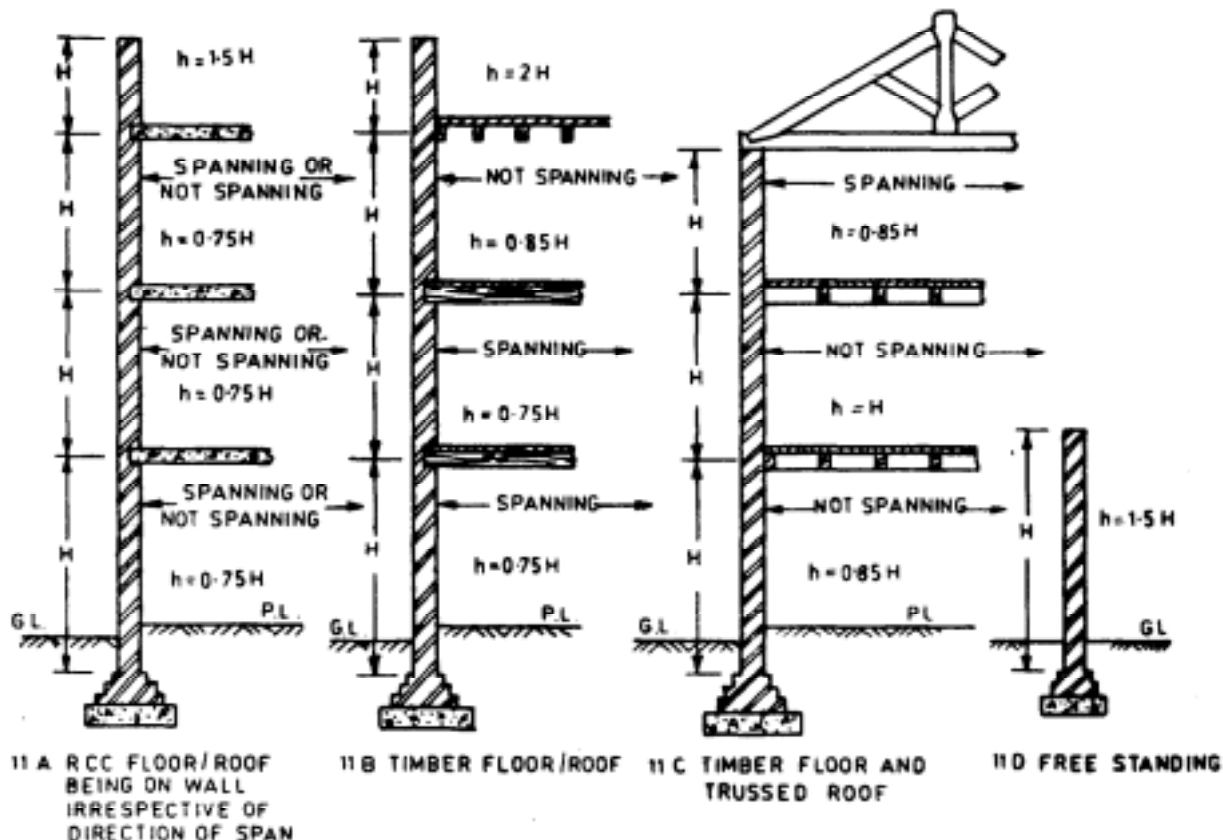

FIG. 11 EFFECTIVE HEIGHT OF WALL

4.4 Effective Length — Effective length of a wall shall be as given in Table 5.

TABLE 5 EFFECTIVE LENGTH OF WALLS

Sl. No. (1)	CONDITIONS OF SUPPORT (see FIG. 13) (2)	EFFECTIVE LENGTH (3)
1.	Where a wall is continuous and is supported by cross wall, and there is no opening within a distance of $H/8$ from the face of cross wall or Where a wall is continuous and is supported by piers/butresses conforming to 4.2.1.2 (b)	$0.8 L$
2.	Where a wall is supported by a cross wall at one end and continuous with cross wall at other end or Where a wall is supported by a pier/butress at one end and continuous with pier/butress at other end conforming to 4.2.1.2 (b)	$0.9 L$
3.	Where a wall is supported at each end by cross wall or Where a wall is supported at each end by a pier/butress conforming to 4.2.1.2 (b)	$1.0 L$

(Continued)

TABLE 5 EFFECTIVE LENGTH OF WALLS—Contd

Sl. No. (1)	CONDITIONS OF SUPPORT (see FIG. 13) (2)	EFFECTIVE LENGTH (3)
4.	Where a wall is free at one end and continuous with a cross wall at the other end or Where a wall is free at one end and continuous with a pier/butress at the other end conforming to 4.2.1.2 (b)	$1.5 L$
5.	Where a wall is free at one end and supported at the other end by a cross wall or Where a wall is free at one end and supported at the other end by a pier/butress conforming to 4.2.1.2 (b) where H = actual height of wall between centres of adequate lateral support; and L = length of wall from or between centres of cross wall, piers or buttresses.	$2.0 L$

NOTE — In case there is an opening taller than $0.5 H$ in a wall, ends of the wall at the opening shall be considered as free.

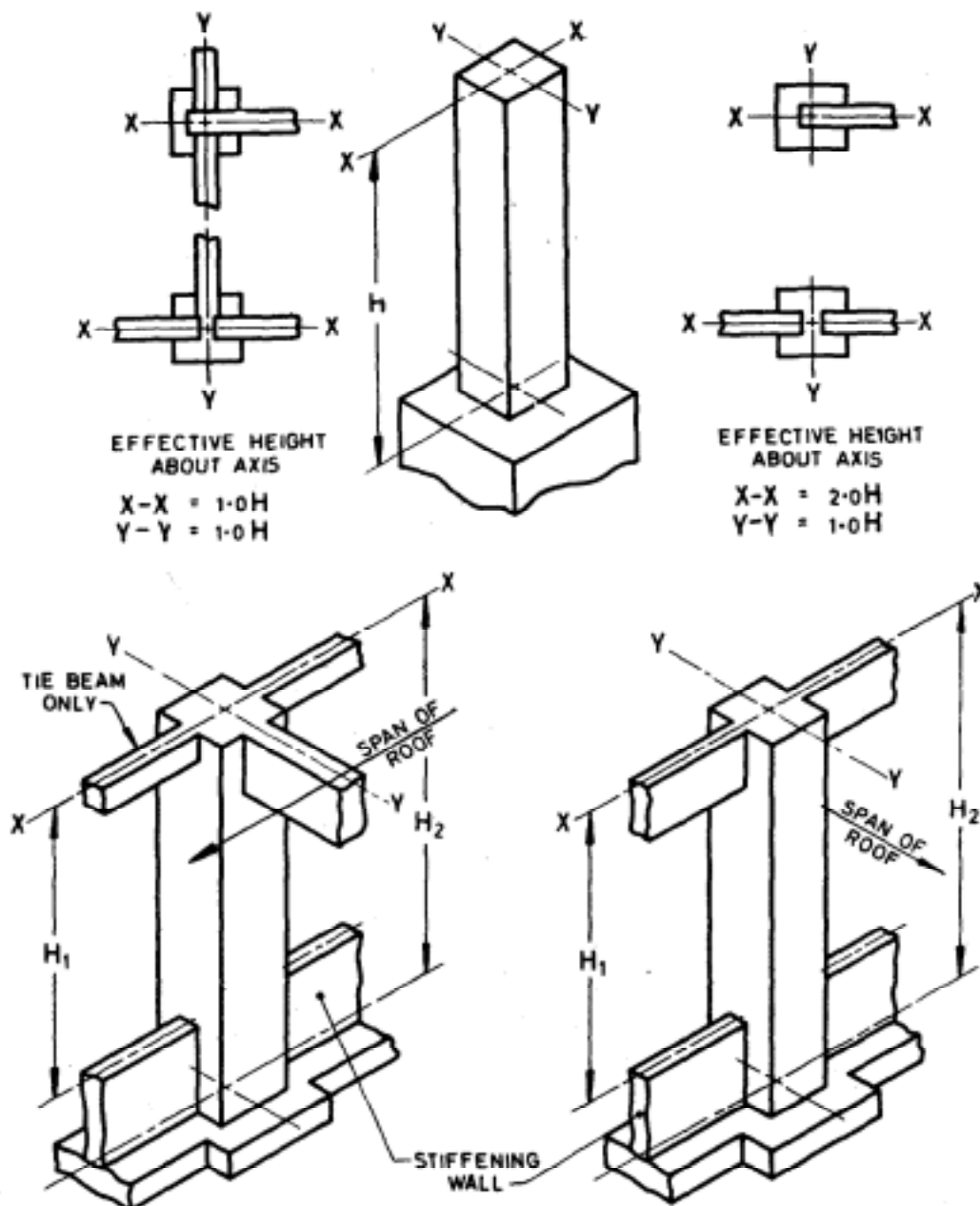

FIG. 12 EXAMPLES OF EFFECTIVE HEIGHT OF COLUMNS

4.5 Effective Thickness — Effective thickness to be used for calculating slenderness ratio of a wall or column shall be obtained as in 4.5.1 to 4.5.4.

4.5.1 For solid walls, faced walls or columns, effective thickness shall be the actual thickness.

4.5.2 For solid walls adequately bonded into piers/butresses, effective thickness for determining slenderness ratio based on effective height shall be the actual thickness of wall multiplied by stiffening coefficient as given in Table 6. No modification in effective thickness, however,

shall be made when slenderness ratio is to be based on effective length of walls.

4.5.3 For solid walls or faced walls stiffened by cross walls, appropriate stiffening coefficient may be determined from Table 6 on the assumption that the cross walls are equivalent to piers of width equal to the thickness of the cross wall and of thickness equal to three times the thickness of stiffened wall.

4.5.4 For cavity walls with both leaves of uniform thickness throughout, effective thickness

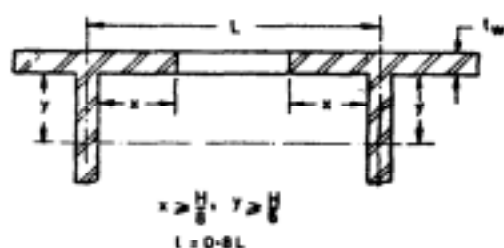

13A

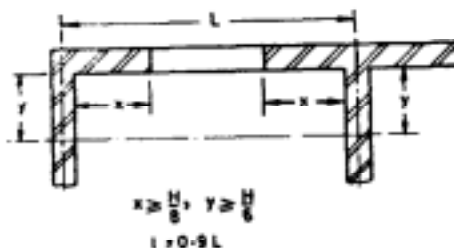

13B



13C

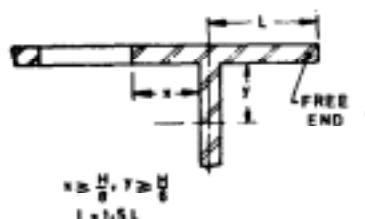

13D

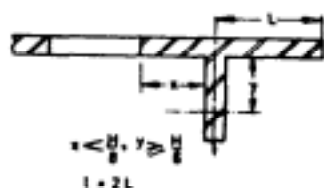

13E

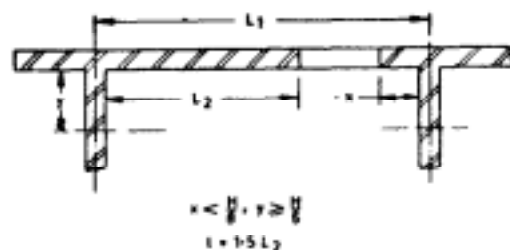

13F

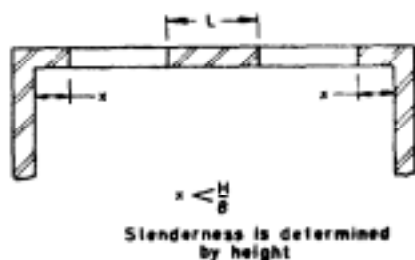

13G

FIG. 13 EFFECTIVE LENGTH OF WALL

be taken as two-thirds the sum of the actual thickness of the two leaves.

4.5.5 For cavity walls with one or both leaves adequately bonded into piers, buttresses or cross walls at intervals, the effective thickness of the cavity wall shall be two-thirds the sum of the effective thickness of each of the two leaves; the effective thickness of each leaf being calculated using 4.5.1 or 4.5.2 as appropriate.

4.6 Slenderness Ratio

4.6.1 Walls — For a wall, slenderness ratio shall be effective height divided by effective

TABLE 6 STIFFENING COEFFICIENT FOR WALLS STIFFENED BY PIERS, BUTTRESSES OR CROSS WALLS

(Clauses 4.5.2 and 4.5.3)

SL No.	$\frac{S_p}{w_p}$ RATIO	STIFFENING COEFFICIENT		
		$\frac{t_p}{t_w} = 1$	$\frac{t_p}{t_w} = 2$	$\frac{t_p}{t_w} = 3$ or more
(1)	(2)	(3)	(4)	(5)
1	6	1.0	1.4	2.0
2	8	1.0	1.3	1.7
3	10	1.0	1.2	1.4
4	15	1.0	1.1	1.2
5	20 or more	1.0	1.0	1.0

where

S_p = centre-to-centre spacing of the pier or cross wall,

t_p = the thickness of pier as defined in 2.3.2 (see Fig. 1),

t_w = actual thickness of the wall proper (see Fig. 1), and

w_p = width of the pier in the direction of the wall or the actual thickness of the cross wall.

NOTE — Linear interpolation between the values given in this table is permissible but not extrapolation outside the limits given.

thickness or effective length divided by the effective thickness, whichever is less. In case of a load bearing wall, slenderness ratio shall not exceed that given in Table 7.

TABLE 7 MAXIMUM SLENDERNESS RATIO FOR A LOAD BEARING WALL

NO. OF STOREYS	MAXIMUM SLENDERNESS RATIO	
	Using Portland Cement or Portland Pozzolana Cement in Mortar	Using Lime Mortar
(1)	(2)	(3)
Not exceeding 2	27	20
Exceeding 2	27	13

4.6.2 Columns — For a column, slenderness ratio shall be taken to be the greater of the ratios of effective heights to the respective effective thickness in the two principal directions. Slenderness ratio for a load bearing column shall not exceed 12.

4.7 Eccentricity — Eccentricity of vertical loading at a particular junction in a masonry wall shall depend on factors, such as extent of bearing, magnitude of loads, stiffness of slab or beam, fixity at the support and constructional details at junctions. No exact calculations are possible to make accurate assessment of eccentricity. Extent of eccentricity under any particular circumstances has, therefore, to be decided according to the best judgement of the designer. Some guidelines for assessment of eccentricity are given in Appendix A.

5. STRUCTURAL DESIGN

5.1 General — The building as a whole shall be analyzed by accepted principles of mechanics to ensure safe and proper functioning in service of its component parts in relation to the whole building. All component parts of the structure shall be capable of sustaining the most adverse combinations of loads, which the building may be reasonably expected to be subjected to during and after construction.

5.2 Design Loads — Loads to be taken into consideration for designing masonry components of a structure are:

- dead loads of walls, columns, floors and roofs;
- live loads of floors and roof;
- wind loads on walls and sloping roof; and
- seismic forces.

NOTE — When a building is subjected to other loads, such as vibration from railways and machinery, these should be taken into consideration according to the best judgement of the designer.

5.2.1 Dead Loads — Dead loads shall be calculated on the basis of unit weights taken in accordance with IS : 1911-1967*.

5.2.2 Live Loads and Wind Loads — Design loads shall be in accordance with the recommendations of IS : 875-1964† or such other loads and forces as may reasonably be expected to be imposed on the structure either during or after construction.

NOTE — During construction, suitable measures shall be taken to ensure that masonry is not liable to damage of failure due to action of wind forces, back filling behind walls or temporary construction loads.

5.2.3 Seismic Loads — For buildings to be constructed in seismic zones I and II (see IS : 1893-1984‡), it is not necessary to consider seismic forces in design calculations. In seismic zones III, IV and V, strengthening measures suggested in IS : 4326-1976§ shall be adopted.

5.3 Load Dispersion

5.3.1 General — The angle of dispersion of vertical load on walls shall be taken as not more than 30° from the vertical.

5.3.2 Arching Action — Account may also be taken of the arching action of well-bonded masonry walls supported on lintels and beams, in accordance with established practice. Increased axial stresses in the masonry associated with arching action in this way, shall not exceed the permissible stresses given in 5.4.

5.3.3 Lintels — Lintels, that support masonry construction, shall be designed to carry loads from masonry (allowing for arching and dispersion, where applicable) and loads received from any other part of the structure. Length of bearing of lintel at each end shall not be less than 9 cm or one-tenth of the span, whichever is more, and area of the bearing shall be sufficient to ensure that stresses in the masonry (combination of wall stresses, stresses due to arching action and bearing stresses from the lintel) do not exceed the stresses permitted in 5.4 (see Appendix C).

5.4 Permissible Stresses

5.4.1 Permissible Compressive Stress — Permissible compressive stress in masonry shall be based on the value of basic compressive stress (f_b) as given in Table 8 and multiplying this value by factor known as stress reduction factor (k_s). Area reduction factor (k_a) and shape modification factor (k_p) as detailed in 5.4.1.1 to 5.4.1.3.

*Schedule of unit weights of building materials (first revision).

†Code of practice for structural safety of buildings: Loading standards (revised).

‡Criteria for earthquake resistant design of structures (fourth revision).

§Code of practice for earthquake resistant design and construction of buildings (first revision).

TABLE 8 BASIC COMPRESSIVE STRESSES FOR MASONRY (AFTER 28 DAYS)
(Clause 5.4.1)

Sl. No.	MORTAR TYPE (REF TABLE 1)	BASIC COMPRESSIVE STRESSES IN N/mm^2 CORRESPONDING TO MASONRY UNITS OF WHICH HEIGHT TO WIDTH RATIO DOES NOT EXCEED 0.75 AND CRUSHING STRENGTH IN N/mm^2 IS NOT LESS THAN											
		3.5	5.0	7.5	10	12.5	15	17.5	20	25	30	35	40
(1)	(2)	(3)	(4)	(5)	(6)	(7)	(8)	(9)	(10)	(11)	(12)	(13)	(14)
1	H1	0.35	0.50	0.75	1.00	1.16	1.31	1.45	1.59	1.91	2.21	2.5	3.05
2	H2	0.35	0.50	0.74	0.96	1.09	1.19	1.30	1.41	1.62	1.85	2.1	2.5
3	M1	0.35	0.50	0.74	0.96	1.06	1.13	1.20	1.27	1.47	1.69	1.9	2.2
4	M2	0.35	0.44	0.59	0.81	0.94	1.03	1.10	1.17	1.34	1.51	1.65	1.9
5	M3	0.25	0.41	0.56	0.75	0.87	0.95	1.02	1.10	1.25	1.41	1.55	1.78
6	L1	0.25	0.36	0.53	0.67	0.76	0.83	0.90	0.97	1.11	1.26	1.4	1.06
7	L2	0.25	0.31	0.42	0.53	0.58	0.61	0.65	0.69	0.73	0.78	0.85	0.95

NOTE 1 — The table is valid for slenderness ratio up to 6 and loading with zero eccentricity.

NOTE 2 — The values given for basic compressive stress are applicable only when the masonry is properly cured.

NOTE 3 — Linear interpolation is permissible for units having crushing strengths between those given in the table.

NOTE 4 — The permissible stress for random rubble masonry may be taken as 75 percent of the corresponding stress for coarsed walling of similar materials.

NOTE 5 — The strength of ashlar masonry (natural stone masonry of massive type with thin joints) is closely related to intrinsic strength of the stone and allowable working stress in excess of those given in the table may be allowed for such masonry at the discretion of the designer.

Values of basic compressive stress given in Table 8 take into consideration crushing strength of masonry unit and grades of mortar, and hold good for values of S R not exceeding 6, zero eccentricity and masonry unit having height to width ratio (as laid) equal to 0.75 or less.

Alternatively, basic compressive stress may be based on results of prism test as given in Appendix B on masonry made from masonry units and mortar to be actually used in a particular job.

5.4.1.1 Stress reduction factor — This factor, as given in Table 9, takes into consideration the slenderness ratio of the element and also the eccentricity of loading.

5.4.1.2 Area reduction factor — This factor takes into consideration smallness of the sectional area of the element and is applicable when sectional area of the element is less than $0.2 m^2$. The factor, $k_a = 0.7 + 1.5 A$, A being the area of section in m^2 .

5.4.1.3 Shape modification factor — This factor takes into consideration the shape of the unit, that is, height to width ratio (as laid) and is given in Table 10. This factor is applicable for units of crushing strength up to $15 N/mm^2$.

5.4.1.4 Increase in permissible compressive stresses allowed for eccentric vertical loads and lateral loads under certain conditions — In members subjected to eccentric and/or lateral loads, increase in permissible compressive stress is allowed as follows:

- a) When resultant eccentricity ratio exceeds $1/24$ but does not exceed $1/6$, 25 percent

TABLE 9 STRESS REDUCTION FACTOR FOR SLENDERNESS RATIO AND ECCENTRICITY
(Clause 5.4.1.1)

SLENDERNESS RATIO	ECCENTRICITY OF LOADING DIVIDED BY THE THICKNESS OF THE MEMBER					
	0	1/24	1/12	1/6	1/4	1/3
(1)	(2)	(3)	(4)	(5)	(6)	(7)
6	1.00	1.00	1.00	1.00	1.00	1.00
8	0.95	0.15	0.94	0.93	0.92	0.91
10	0.89	0.88	0.87	0.85	0.83	0.81
12	0.84	0.83	0.81	0.78	0.75	0.72
14	0.78	0.76	0.74	0.70	0.66	0.66
16	0.73	0.71	0.68	0.63	0.58	0.53
18	0.67	0.64	0.61	0.55	0.49	0.43
20	0.62	0.59	0.55	0.48	0.41	0.34
22	0.56	0.52	0.48	0.40	0.32	0.24
24	0.51	0.47	0.42	0.33	0.24	—
26	0.45	0.40	0.35	0.25	—	—
27	0.43	0.38	0.33	0.22	—	—

NOTE 1 — Linear interpolation between values is permitted.

NOTE 2 — Where, in special cases, the eccentricity of loading lies between $1/3$ and $1/2$ of the thickness of the member, the stress reduction factor should vary linearly between unity and 0.20 for slenderness ratio of 6 and 20 respectively.

NOTE 3 — Slenderness ratio of a member for sections within $1/8$ of the height of the member above or below a lateral support may be taken to be 6.

increase in permissible compressive stress is allowed in design.

- b) When resultant eccentricity ratio exceeds $1/6$, 25 percent increase in permissible stress is allowed but the area of the section under tension shall be disregarded for computing the load carrying capacity of the member.

TABLE 10 SHAPE MODIFICATION FACTOR FOR MASONRY UNITS
(Clause 5.4.1.3)

HEIGHT TO WIDTH RATIO OF UNITS (AS LAID)	SHAPE MODIFICATION FACTOR (k_p) FOR UNITS HAVING CRUSHING STRENGTH IN N/mm^2			
	5.0	7.5	10.0	15.0
(1)	(2)	(3)	(4)	(5)
Up to 0.75	1.0	1.0	1.0	1.0
1.0	1.2	1.1	1.1	1.0
1.5	1.5	1.3	1.2	1.1
2.0 to 4.0	1.8	1.5	1.3	1.2

NOTE — Linear interpolation between values is permissible.

NOTE — When resultant eccentricity ratio of loading is $1/24$ or less, compressive stress due to bending shall be ignored and only axial stress need be computed for the purpose of design.

5.4.1.5 Increase in permissible compressive stress for walls subjected to concentrated loads —

When a wall is subjected to a concentrated load (a load being taken to be concentrated when area of supporting walls equals or exceeds three times the bearing area), certain increase in permissible compressive stress may be allowed because of dispersal of the load. Since, according to the present state of art, there is diversity of views in regard to manner and extent of dispersal, design of walls subjected to concentrated load may, therefore, be worked out as per the best judgement of the designer. Some guidelines in this regard are given in Appendix C.

5.4.2 Permissible Tensile Stress — As a general rule, design of masonry shall be based on the assumption that masonry is not capable of taking any tension. However, in case of lateral loads normal to the plane of wall, which causes flexural tensile stress, as for example, panel, curtain partition and free-standing walls, flexural tensile stresses as follows may be permitted in the design for masonry:

- Grade M1 or better mortar — 0.07 N/mm^2 for bending in the vertical direction where tension developed is normal to bed joints.
- 0.14 N/mm^2 for bending in the longitudinal direction where tension developed is parallel to bed joints, provided crushing strength of masonry units is not less than 10 N/mm^2 .
- Grade M2 mortar — 0.05 N/mm^2 for bending in the vertical direction where tension developed is normal bed joints.
- 0.10 N/mm^2 for bending in the longitudinal direction where tension developed is

parallel to bed joints, provided crushing strength of masonry units is not less than 7.5 N/mm^2 .

NOTE 1 — No tensile stress is permitted in masonry in case of water-retaining structures in view of water in contact with masonry. Also no tensile stress is permitted in earth-retaining structures in view of the possibility of presence of water at the back of such walls.

NOTE 2 — Allowable tensile stress in bending in the vertical direction may be increased to 0.1 N/mm^2 for M1 mortar and 0.07 N/mm^2 for M2 mortar in case of boundary walls/compound walls at the discretion of the designer.

5.4.3 Permissible Shear Stress — In case of walls built in mortar not leaner than Grade M1 (see Table 1) and resisting horizontal forces in the plane of the wall, permissible shear stress, calculated on the area of bed joint, shall not exceed the value obtained by the formula given below, subject to a maximum of 0.5 N/mm^2 :

$$f_s = 0.1 + f_d/6$$

where:

f_s = permissible shear stress in N/mm^2 , and

f_d = compressive stress due to dead loads in N/mm^2 .

5.4.4 If there is tension in any part of a section of masonry, the area under tension shall be ignored while working out shear stress on the section.

5.5 Design Thickness/Cross-Section

5.5.1 Walls and Columns Subjected to Vertical Loads — Walls and columns bearing vertical loads shall be designed on the basis of permissible compressive stress. Design consists in determining thickness in case of walls and section in case of columns in relation to strength of masonry units and grade of mortar to be used, taking into consideration various factors such as slenderness ratio, eccentricity, area of section, workmanship, quality of supervision, etc, subject further to provisions of 5.5.1.1 to 5.5.1.4.

5.5.1.1 Solid walls — Thickness used for design calculation shall be the actual thickness of masonry computed as the sum of the average dimensions of the masonry units specified in the relevant standard, together with the specified joint thickness. In masonry with raked joints, thickness shall be reduced by the depth of raking of joints for plastering/pointing.

5.5.1.2 Cavity walls

- Thickness of each leaf of a cavity wall shall not be less than 7.5 cm.
- Where the outer leaf is half masonry unit in thickness, the uninterrupted height and

length of this leaf shall be limited so as to avoid undue loosening of ties due to differential movements between two leaves. The outer leaf shall, therefore, be supported at least at every third storey or at every 10 m of height, whichever is less, and at every 10 m or less along the length.

- c) Where the load is carried by both leaves of a wall of a cavity construction, the permissible stress shall be based on the slenderness ratio derived from the effective thickness of the wall as given in 4.5.4 or 4.5.5. The eccentricity of the load shall be considered with respect to the centre of gravity of the cross-section of the wall.
- d) Where the load is carried by one leaf only, the permissible stress shall be the greater of values calculated by the following two alternative methods:
 - 1) The slenderness ratio is based on the effective thickness of the cavity wall as a whole as given in 4.5.4 or 4.5.5 and on the eccentricity of the load with respect to the centre of gravity of the cross-section of the whole wall (both leaves). (This is the same method as where the load is carried by both the leaves but the eccentricity will be more when the load is carried by one leaf only.)
 - 2) The slenderness ratio is based on the effective thickness of the loaded leaf only using 4.5.1 and 4.5.2, and the eccentricity of the load will also be with respect to the centre of gravity of the loaded leaf only.

In either alternative, only the actual thickness of the load bearing leaf shall be used in arriving at the cross-sectional area resisting the load (see 5.5.1.1).

5.5.1.3 Faced wall — The permissible load per length of wall shall be taken as the product of the total thickness of the wall and the permissible stress in the weaker of the two materials. The permissible stress shall be found by using the total thickness of the wall when calculating the slenderness ratio.

5.5.1.4 Veneered wall — The facing (veneer) shall be entirely ignored in calculations of strength and stability. For the purpose of determining the permissible stress in the backing, the slenderness ratio shall be based on the thickness of the backing alone.

5.5.2 Walls and Columns Mainly Subjected to Lateral Loads

5.5.2.1 Free-standing walls:

- a) Free-standing walls, subjected to wind pressure or seismic forces, shall be designed on the basis of permissible tensile stress in masonry or stability as in 4.2.2.4. However, in seismic zones I and II, free-standing walls may be apportioned without making any design calculations with the help of Table II, provided the mortar used is of grade not leaner than M1.
- b) If there is a horizontal damp-proof course near the base of the wall that is not capable of developing tension vertically, the minimum wall thickness should be the greater of that calculated from either:
 - 1) the appropriate height to thickness ratio given in Table II reduced by 25 percent, reckoning the height from the level of the damp-proof course; or
 - 2) the appropriate height to thickness ratio given in Table II reckoning the height from the lower level at which the wall is restrained laterally.

TABLE II HEIGHT TO THICKNESS RATIO OF FREE-STANDING WALLS RELATED TO WIND SPEED

DESIGN WIND PRESSURE (1) N/m ²	HEIGHT TO THICKNESS RATIO (2)
Up to 285	10
575	7
860	5
1150	4

NOTE 1 — For intermediate values, linear interpolation is permissible.

NOTE 2 — Height is to be reckoned from 15 cm below ground level or top of footing/foundation block, whichever is higher, and up to the top edge of the wall.

NOTE 3 — The thickness should be measured including the thickness of the plaster.

5.5.2.2 Retaining walls — Normally masonry of retaining walls shall be designed on the basis of zero-tension, and permissible compressive stress. However, in case of retaining walls for supporting horizontal thrust from dry materials, retaining walls may be designed on the basis of permissible tensile stress at the discretion of the designers.

5.5.3 Walls and Columns Subjected to Vertical as Well as Lateral Loads — For walls and columns, stresses worked out separately for vertical loads as in 5.5.1 and lateral loads as in 5.5.2, shall be combined and elements designed on the basis of permissible stresses.

5.5.4 Walls Subjected to In-Plane Bending and Vertical Loads (Shear Walls) — Walls subjected to in-plane bending and vertical loads, that is, shear walls shall be designed on the basis of no-tension, permissible shear stress and permissible compressive stress.

5.5.5 Non-load Bearing Walls — Non-load bearing walls, such as panel walls, curtain walls and partition walls which are mainly subjected to lateral loads, according to present state of art, are not capable of precise design and only approximate methods based on some tests are available. Guidelines for approximate design of these walls are given in Appendix D.

6. GENERAL REQUIREMENTS

6.1 Methods of Construction

6.1.1 General — The methods adopted in the construction of load bearing and non-load bearing shall comply with the following standards:

Brickwork	IS : 2212-1962*
Stone masonry	IS : 1597 (Part 1)-1967† IS : 1597 (Part 2)-1967‡
Hollow concrete block masonry	IS : 2572-1963§
Autoclaved cellular concrete block masonry	IS : 6041-1985]
Lightweight concrete block masonry	IS : 6042-1969¶
Gypsum partition blocks	IS : 2849-1983**

6.1.2 Construction of Buildings in Seismic Zones — No special provisions on construction are necessary for buildings constructed in zones I and II. Special features of construction for earthquake resistant masonry buildings in zones III, IV and V shall be applicable as given in IS : 4326-1976††.

6.2 Minimum Thickness of Walls from Consideration ther Othan Structural — Thickness of walls

*Code of practice for brickwork.

†Code of practice for construction of stone masonry : Part 1 Rubble stone masonry.

‡Code of practice for construction of stone masonry : Part 2 Ashlar masonry.

§Code of practice for construction of hollow concrete block masonry.

]Code of practice for construction of autoclaved cellular concrete block masonry (first revision).

¶Code of practice for construction of lightweight concrete block masonry.

**Specification for non-load bearing gypsum partition blocks (solid and hollow types) (first revision).

††Code of practice for earthquake resistant construction of buildings (first revision).

determined from consideration of strength and stability may not always be adequate in respect of other requirements such as resistance to fire, thermal insulation, sound insulation and resistance to damp penetration for which reference may be made to the appropriate Indian Standards, and thickness suitably increased, where found necessary.

6.3 Workmanship

6.3.1 General — Workmanship has considerable effect on strength of masonry and bad workmanship may reduce the strength of brick masonry to as low as half the intended strength. The basic compressive stress values for masonry as given in Table 8 would hold good for commercially obtainable standards of workmanship with reasonable degree of supervision. If the work is inadequately supervised, strength should be reduced to three-fourths or less at the discretion of the designer.

6.3.2 Bedding of Masonry Units — Masonry units shall be laid on a full bed or mortar with frog, if any, upward such that cross-joints and wall joints are completely filled with mortar. Masonry units which are moved after initial placement shall be relaid in fresh mortar, discarding the disturbed mortar.

6.3.3 Bond — Cross-joints in any course of one brick thick masonry wall shall be not less than one-fourth of a masonry unit in horizontal direction from the cross-joints in the course below. In masonry walls more than one brick in thickness, bonding through the thickness of wall shall be provided by either header units or by other equivalent means conforming to the requirements of IS : 2212-1962*.

6.3.4 Verticality and Alignment — All masonry shall be built true and plumb within the tolerances prescribed below. Care shall be taken to keep the perpend properly aligned.

- Deviation from vertical within a storey shall not exceed 6 mm per 3 m height.
- Deviation in verticality in total height of any wall of a building more than one storey in height shall not exceed 12.5 mm.
- Deviation from position shown on plan of any brickwork shall not exceed 12.5 mm.
- Relative displacement between load bearing walls in adjacent storeys intended to be in vertical alignment shall not exceed 6 mm.
- Deviation of bed-joint from horizontal in a length of 12 m shall not exceed 6 mm subject to a maximum deviation of 12 mm.

*Code of practice for brickwork.

- f) Deviation from the specified thickness of bed-joints, cross-joints and perpends shall not exceed one-fifth of the specified thickness.

Note — These tolerances have been specified from point of view of their effect on the strength of masonry. The permissible stresses recommended in 5.3 may be considered applicable only if these tolerances are adhered to.

6.4 Joints to Control Deformation and Cracking — Special provision shall be made to control or isolate thermal and other movements so that damage to the fabric of the building is avoided and its structural sufficiency preserved. Design and installation of joints shall be done according to the appropriate recommendations of IS : 3414-1968*.

6.5 Chases, Recesses and Holes

6.5.1 Chases, recesses and holes are permissible in masonry only if these do not impair strength and stability of the structure.

6.5.2 In masonry, designed by structural analysis, all chases, recesses and holes shall be considered in structural design and detailed in building plans.

6.5.3 When chases, recesses and holes have not been considered in structural design are not shown in drawings, these may be provided subject to the constraints and precautions specified in 6.5.3.1 to 6.5.3.10.

6.5.3.1 As far as possible, services should be planned with the help of vertical chases and use of horizontal chases should be avoided.

6.5.3.2 For load bearing walls, depth of vertical and horizontal chases shall not exceed one-third and one-sixth of the wall thickness respectively.

6.5.3.3 Vertical chases shall not be closer than 2 m in any stretch of wall and shall not be located within 34.5 cm of an opening or within 23 cm of a cross wall that serves as a stiffening wall for stability. Width of a vertical chase shall not exceed thickness of wall in which it occurs.

6.5.3.4 When unavoidable horizontal chases of width not exceeding 6 cm in a wall having slenderness ratio not exceeding 15 may be provided. These shall be located in the upper or lower middle third height of wall at a distance not less than 60 cm from a lateral support. No horizontal chase shall exceed one metre in length and there shall not be more than 2 chases in any one wall. Horizontal chases shall have minimum mutual separation distance of 50 cm. Sum of lengths of all chases and recesses in any horizontal plane shall not exceed one-fourth the length of the wall.

*Code of practice for design and installation of joints in buildings.

6.5.3.5 Holes for supporting put-logs of scaffolding shall be kept away from bearings of beams, lintels and other concentrated loads. If unavoidable, stresses in the affected area shall be checked to ensure that these are within safe limits.

6.5.3.6 No chase, recess or hole shall be provided in any stretch of a masonry wall, the length of which is less than four times the thickness of wall, except when found safe by structural analysis.

6.5.3.7 Masonry directly above a recess or a hole, if wider than 30 cm, shall be supported on a lintel. No lintel, however, is necessary in case of a circular recess or a hole exceeding 30 cm in diameter provided upper half of the recess or hole is built as a semi-circular arch of adequate thickness and there is adequate length of masonry on the sides of openings to resist the horizontal thrust.

6.5.3.8 As far as possible, chases, recesses and holes in masonry should be left (inserting sleeves, where necessary) at the time of construction of masonry so as to obviate subsequent cutting. If cutting is unavoidable, it should be done without damage to the surrounding or residual masonry. It is desirable to use such tools for cutting which depend upon rotary and not on heavy impact for cutting action.

6.5.3.9 No chase, recess or hole shall be provided in half-brick load bearing wall, excepting the minimum number of holes needed for scaffolding.

6.5.3.10 Chases, recesses or holes shall not be cut into walls made of hollow or perforated units, after the units have been incorporated in masonry.

6.6 Corbelling

6.6.1 Where corbelling is required for the support of some structural element, maximum projection of masonry unit should not exceed one-half of the height of the unit or one-half of the built-in part of the unit and the maximum horizontal projection of the corbel should not exceed one-third of the wall thickness.

6.6.2 The load per unit length on a corbel shall not be greater than half of the load per unit length on the wall above the corbel. The load on the wall above the corbel together with four times the load on the corbel, shall not cause the average stress in the supporting wall or leaf to exceed the permissible stresses given in 5.4.

6.6.3 It is preferable to adopt header courses in the corbelled portion of masonry from considerations of economy and stability.

7. NOTATIONS AND SYMBOLS

7.1 The various notations and letter symbols used in the text of the standard shall have the meaning as given in Appendix E.

APPENDIX A

(Clause 4.7)

SOME GUIDELINES FOR ASSESSMENT OF ECCENTRICITY OF LOADING ON WALLS

A-1. Where a reinforced concrete roof and floor slab of normal span (not exceeding 30 times the thickness of wall) bear on external masonry walls, the point of application of the vertical loading shall be taken to be at the centre of the bearing on the wall. When the span is more than 30 times the thickness of wall, the point of application of the load shall be considered to be displaced from the centre of bearing towards the span of the floor to an extent of one-sixth the bearing width.

A-2. In case of a reinforced concrete slab of normal span (that is, less than 30 times the thickness of the wall), which does not bear on the full width of the wall and 'cover tiles or bricks' are provided on the external face, there is some eccentricity of load. The eccentricity may be assumed to be one-twelfth of the thickness of the wall.

A-3. Eccentricity of load from the roof/floor increases with the increase in flexibility and thus deflection of the slabs. Also, eccentricity of loading increases with the increase in fixity of slabs/beams at supports. Precast RCC slabs are better than *in-situ* slabs in this regard because of very little fixity. If supports are released before further construction on top, fixity is reduced.

A-4. Interior walls carrying continuous floors are assumed to be axially loaded except when carrying very flexible floor or roof systems. The assumption is valid also for interior walls carrying

independent slabs spanning from both sides, provided the span of the floor on one side does not exceed that on the other by more than 15 percent. Where the difference is greater, the displacement of the point of application of each floor load shall be taken as one-sixth of its bearing width on the wall and the resultant eccentricity calculated therefrom.

A-5. For timber and other lightweight floors, even for full width bearing on wall, an eccentricity of about one-sixth may be assumed due to deflection. For timber floors with larger spans, that is, more than 30 times the thickness of the wall, eccentricity of one-third the thickness of the wall may be assumed.

A-6. In multi-storeyed buildings, fixity and eccentricity have normally purely local effect and are not cumulative. They just form a constant ripple on the downward increasing axial stress. If the ripple is large, it is likely to be more serious at upper levels where it can cause cracking of walls than lower down where it may or may not cause local over-stressing.

NOTE—The resultant eccentricity of the total loads on a wall at any level may be calculated on the assumption that immediately above a horizontal lateral support, the resultant eccentricity of all the vertical loads above that level is zero.

A-7. For a wall corbel to support some load, the point of application of the load shall be assumed to be at the centre of the bearing on the corbel.

APPENDIX B

(Clause 5.4.1)

CALCULATION OF BASIC COMPRESSIVE STRESS OF MASONRY BY PRISM TEST

B-1. DETERMINATION OF COMPRESSIVE STRENGTH OF MASONRY BY PRISM TEST

B-1.1 When compressive strength of masonry (f'_m) is to be established by tests, it shall be done in advance of the construction, using prisms built of similar materials under the same conditions with the same bonding arrangement as for the structure. In building the prisms, moisture content of the units at the time of laying, the

consistency of the mortar, the thickness of mortar joints and workmanship shall be the same as will be used in the structure. Assembled specimen shall be at least 40 cm high and shall have a height to thickness ratio (h/t) of at least 2 but not more than 5. If the h/t ratio of the prisms tested is less than 5 in case of brickwork and more than 2 in case of blockwork, compressive strength values indicated by the tests shall be corrected by multiplying with the factor indicated in Table 12.

TABLE 12 CORRECTION FACTORS FOR DIFFERENT h/t RATIOS

(Clause B-1.1)

Ratio of height to thickness (h/t)	2.0	2.5	3.0	3.5	4.0	5.0
Correction factors for brickwork*	0.73	0.80	0.86	0.91	0.95	1.00
Correction factors for blockwork*	1.00	—	1.20	—	1.30	1.37

*Interpolation is valid for intermediate values.

Prisms shall be tested after 28 days between

sheets of nominal 4 mm plywood, slightly longer than the bed area of the prism, in a testing machine, the upper platform of which is spherically seated. The load shall be evenly distributed over the whole top and bottom surfaces of the specimen and shall be applied at the rate of 350 to 700 kN/m. The load at failure should be recorded.

B-2. CALCULATION OF BASIC COMPRESSIVE STRESS

B-2.1 Basic of masonry shall be taken to be equal to $0.25 f'_m$ where f'_m is the value of compressive strength of masonry as obtained from prism test.

APPENDIX C

(Clauses 5.3.3 and 5.4.1.5)

GUIDELINES FOR DESIGN OF MASONRY SUBJECTED TO CONCENTRATED LOADS

C-1. EXTENT OF DISPERSAL OF CONCENTRATED LOAD

C-1.1 For concentric loading, maximum spread of a concentrated load on a wall may be taken to be equal to $b+4t$ (b is width of bearing and t is thickness of wall), or stretch of wall supporting the load, or centre-to-centre distance between loads, whichever is less.

C-2. INCREASE IN PERMISSIBLE STRESS

C-2.1 When a concentrated load bears on a central strip of wall, not wider than half the thickness of the wall and is concentric, bearing stress in masonry may exceed the permissible compressive by 50 percent, provided the area of supporting wall is not less than three times the bearing area.

C-2.2 If the load bears on full thickness of wall and is concentric, 25 percent increase in stress may be allowed.

C-2.3 For loading on central strip wider than half the thickness of the wall but less than full thickness, increase in stress may be worked out by interpolation between values of increase in stresses as given in C-2.1 and C-2.2.

C-2.4 In case concentrated load is from a lintel over an opening, an increase of 50 percent in permissible stress may be taken, provided the supporting area is not less than 3 times the bearing area.

C-3. CRITERIA OF PROVIDING BED BLOCK

C-3.1 If a concentrated load bears on one end of a wall, there is a possibility of masonry in the upper region developing tension. In such a situation, the load should be supported on an RCC bed block (of M-15 Grade) capable of taking tension.

C-3.2 When any section of masonry wall is subjected to concentrated as well as uniformly distributed load and resultant stress, computed by making due allowance for increase in stress on account of concentrated load, exceeds the permissible stress in masonry, a concrete bed block (of M-15 Grade) should be provided under the load in order to relieve stress in masonry. In concrete, angle of dispersion of concentrated load is taken to be 45° to the vertical.

C-3.3 In case of cantilevers and long span beams supported on masonry walls, indeterminate but very high edge stresses occur at the supports and in such cases it is necessary to relieve stress on masonry by providing concrete bed block of M-15 Grade concrete. Similarly when a wall is subjected to a concentrated load from a beam which is not sensibly rigid (for example, a timber beam or an RS joist), a concrete bed block should be provided below the beam in order to avoid high edge stress in the wall because of excessive deflection of the beam.

APPENDIX D

(Clause 5.5.5)

GUIDELINES FOR APPROXIMATE DESIGN OF NON-LOAD BEARING WALL

D-1. PANEL WALLS

D-1.1 A panel wall may be designed approximately as under, depending upon its support conditions and certain assumptions:

- a) When there are narrow tall windows on either side of panel, the panel spans in the vertical direction. Such a panel may be designed for a bending moment of $PH/8$, where P is the total horizontal load on the panel and H is the height between the centres of supports. Panel wall is assumed to be simply supported in the vertical direction.
- b) When there are long horizontal windows between top support and the panel, the top edge of the panel is free. In this case, the panel should be considered to be supported on sides and at the bottom, and the bending moment would depend upon height to length ratio of panel and flexural strength of masonry. Approximate values of bending moments in the horizontal direction for this support condition, when ratio (μ) of flexural strength of wall in the vertical direction to that in horizontal direction is assumed to be 0.5, are given in Table 13.

TABLE 13 BENDING MOMENTS IN LATERALLY LOADED PANEL WALLS, FREE AT TOP EDGE AND SUPPORTED ON OTHER THREE EDGES

Height of Panel, H Length of Panel, L	0.30	0.50	0.75	1.00	1.25	1.50	1.75
Bending moment	$\frac{PL}{25}$	$\frac{PL}{18}$	$\frac{PL}{14}$	$\frac{PL}{12}$	$\frac{PL}{11}$	$\frac{PL}{10.5}$	$\frac{PL}{10}$

NOTE — For H/L ratio less than 0.30, the panel should be designed as a free-standing wall and for H/L ratio exceeding 1.75, it should be designed as a horizontally spanning member for a bending moment value of $PL/8$.

- c) When either there are no window openings or windows are of 'hole-in-wall' type, the panel is considered to be simply supported on all four edges. In this case also, amount of maximum bending moment depends on height to length ratio of panel and ratio (μ) of flexural strength of masonry in vertical direction to that in the horizontal direction. Approximate values for maximum bending moment in the horizontal direction for masonry with

$\mu = 0.50$, are given in Table 14.

TABLE 14 BENDING MOMENTS IN LATERALLY LOADED PANEL WALLS SUPPORTED ON ALL FOUR EDGES

Height of panel, H Length of panel, L	0.30	0.50	0.75	1.00	1.25	1.50	1.75
Bending moment	$\frac{PL}{72}$	$\frac{PL}{36}$	$\frac{PL}{24}$	$\frac{PL}{18}$	$\frac{PL}{15}$	$\frac{PL}{13}$	$\frac{PL}{12}$

NOTE — When H/L is less than 0.30, value of bending moment in the horizontal direction may be taken as nil and panel wall may be designed for a bending moment value of $PH/8$ in the vertical direction; when H/L exceeds 1.75, panel may be assumed to be spanning in the horizontal direction and designed for bending moment of $PL/8$.

D-2. CURTAIN WALLS

D-2.1 Curtain walls may be designed as panel walls taking into consideration the actual supporting conditions.

D-3. PARTITION WALLS

D-3.1 These are internal walls usually subjected to much smaller lateral forces. Behaviour of such wall is similar to that of panel wall and these could, therefore, be designed on similar lines. However, in view of smaller lateral loads, ordinarily these could be apportioned empirically as follows:

- a) Walls with adequate lateral restraint at both ends but not at the top:
 - 1) The panel may be of any height, provided the length does not exceed 40 times the thickness; or
 - 2) The panel may be of any length, provided the height does not exceed 15 times the thickness (that is, it may be considered as a free-standing wall); or
 - 3) Where the length of the panel is over 40 times and less than 60 times the thickness, the height plus twice the length may not exceed 135 times the thickness;
- b) walls with adequate lateral restraint at both ends and at the top:
 - 1) The panel may be of any height, provided the length does not exceed 40 times the thickness; or

- 2) The panel may be of any length, provided the height does not exceed 30 times the thickness; or
 - 3) Where the length of the panel is over 40 times and less than 110 times the thickness, the length plus three times the height should not exceed 200 times the thickness; and
- c) When walls have adequate lateral restraint

at the top but not at the ends, the panel may be of any length, provided the height does not exceed 30 times the thickness.

D-3.2 Strength of bricks used in partition walls should not be less than 3.5 N/mm² or the strength of masonry units used in adjoining masonry, whichever is less. Grade of mortar should not be leaner than M2.

APPENDIX E

(Clause 7.1)

NOTATIONS, SYMBOLS AND ABBREVIATIONS

E-1. The following notations, letter symbols and abbreviations shall have the meaning indicated against each, unless otherwise specified, in the text of the standard:

<p><i>A</i> = Area of a section</p> <p><i>b</i> = Width of bearing</p> <p><i>DPC</i> = Damp proof course</p> <p><i>e</i> = Resultant eccentricity</p> <p><i>f_b</i> = Basic compressive stress</p> <p><i>f_c</i> = Permissible compressive stress</p> <p><i>f_d</i> = Compressive stress due to dead loads</p> <p><i>f_s</i> = Permissible shear stress</p> <p><i>f'_m</i> = Compressive strength of masonry (in prism test)</p> <p><i>GL</i> = Ground level</p> <p><i>H</i> = Actual height between lateral supports</p> <p><i>H'</i> = Height of opening</p> <p><i>H1, H2</i> = High strength mortars</p> <p><i>h</i> = Effective height between lateral supports</p> <p><i>k_a</i> = Area factor</p>	<p><i>k_p</i> = Shape modification factor</p> <p><i>k_s</i> = Stress reduction factor</p> <p><i>L</i> = Actual length of wall</p> <p><i>L1, L2</i> = Lower strength mortars</p> <p><i>M1, M2</i> = Medium strength mortars</p> <p><i>P</i> = Total horizontal load</p> <p><i>PL</i> = Plinth level</p> <p><i>RCC</i> = Reinforced cement concrete</p> <p><i>RS</i> = Rolled steel</p> <p><i>S_p</i> = Spacing of piers/buttresses/cross walls</p> <p><i>SR</i> = Slenderness ratio</p> <p><i>t</i> = Actual thickness</p> <p><i>t_p</i> = Thickness of pier</p> <p><i>t_w</i> = Thickness of wall</p> <p><i>W</i> = Resultant load</p> <p><i>W₁</i> = Axial load</p> <p><i>W₂</i> = Eccentric load</p> <p><i>w_p</i> = Width of piers/buttresses/crosswalls</p> <p><i>μ</i> = Ratio of flexural strength of wall in the vertical direction to that in the horizontal direction.</p>
---	---

Bureau of Indian Standards

BIS is a statutory institution established under the *Bureau of Indian Standards Act, 1986* to promote harmonious development of the activities of standardization, marking and quality certification of goods and attending to connected matters in the country.

Copyright

BIS has the copyright of all its publications. No part of these publications may be reproduced in any form without the prior permission in writing of BIS. This does not preclude the free use, in the course of implementing the standard, of necessary details, such as symbols and sizes, type or grade designations. Enquiries relating to copyright be addressed to the Director (Publications), BIS.

Review of Indian Standards

Amendments are issued to standards as the need arises on the basis of comments. Standards are also reviewed periodically; a standard along with amendments is reaffirmed when such review indicates that no changes are needed; if the review indicates that changes are needed, it is taken up for revision. Users of Indian Standards should ascertain that they are in possession of the latest amendments or edition by referring to the latest issue of 'BIS Handbook' and 'Standards Monthly Additions'.

Amendments Issued Since Publication

Amend No.	Date of Issue	Text Affected

BUREAU OF INDIAN STANDARDS

Headquarters:

Manak Bhavan, 9 Bahadur Shah Zafar Marg, New Delhi 110002
Telephones : 331 01 31, 331 13 75

Telegrams : Manaksanstha
(Common to all offices)

Regional Offices :

Central : Manak Bhavan, 9 Bahadur Shah Zafar Marg
NEW DELHI 110002

Telephone
{ 331 01 31
331 13 75

Eastern : 1/14 C. I.T. Scheme VII M, V. I. P. Road, Maniktola
CALCUTTA 700054

{ 37 84 99, 37 85 61
37 86 26, 37 86 62

Northern : SCO 335-336, Sector 34-A, CHANDIGARH 160022

{ 60 38 43
60 20 25

Southern : C. I. T. Campus, IV Cross Road, MADRAS 600113

{ 235 02 16, 235 04 42
235 15 19, 235 23 15

Western : Manakalaya, E9 MIDC, Marol, Andheri (East)
BOMBAY 400093

{ 632 92 95, 632 78 58
632 78 91, 632 78 92

Branches : AHMADABAD. BANGALORE. BHOPAL. BHUBANESHWAR.
COIMBATORE. FARIDABAD. GHAZIABAD. GUWAHATI. HYDERABAD.
JAIPUR. KANPUR. LUCKNOW. PATNA. THIRUVANANTHAPURAM.