

**IS : 1624 - 1986**  
**(Reaffirmed 2000)**  
**Edition 3.1**  
**(1991-06)**

*Indian Standard*

**METHODS OF  
FIELD TESTING OF BUILDING LIME**

*( Second Revision )*

(Incorporating Amendment No. 1)

UDC 691.51 : 620.1

© BIS 2003

**BUREAU OF INDIAN STANDARDS**  
MANAK BHAVAN, 9 BAHADUR SHAH ZAFAR MARG  
NEW DELHI 110002

**Price Group 2**

*Indian Standard*

METHODS OF  
FIELD TESTING OF BUILDING LIME  
( *Second Revision* )

Building Limes Sectional Committee, BDC 4

*Chairman*

SHRI C. D. THATTE

*Representing*

Gujarat Engineering Research Institute, Vadodara

*Members*

RESEARCH OFFICER (GERI) ( *Alternate to*  
Shri C. D. Thatte )

DR S. C. AHLUWALIA

National Council for Cement and Building Materials,  
New Delhi

SHRI S. P. S. AHUJA

Engineer-in-Chief's Branch (Ministry of Defence),  
New Delhi

MAJ V. K. SURI ( *Alternate* )

SHRI S. K. BANERJEE

National Test House, Calcutta

SHRI D. K. KANUGO ( *Alternate* )

SHRI N. G. BASAK

Directorate General of Technical Development,  
New Delhi

SHRI S. K. GHOSH ( *Alternate* )

SHRI H. U. BIJLANI

All India Housing Development Association,  
New Delhi

SHRI S. J. BAHADUR ( *Alternate* )

SHRI B. K. CHAKRABORTY

Housing and Urban Development Co-operation,  
New Delhi

SHRI P. S. SRIVASTAVA ( *Alternate* )

SHRI S. K. CHAUDHARY

Lime Manufacturers' Association of India, New Delhi

DR N. G. DAVE

Central Building Research Institute (CSIR), Roorkee

SHRI S. K. MALHOTRA ( *Alternate* )

DIRECTOR

A.P. Engineering Research Laboratories, Hyderabad

JOINT DIRECTOR ( *Alternate* )

DIRECTOR

Central Soil and Materials Research Station,  
New Delhi

DEPUTY DIRECTOR ( *Alternate* )

( *Continued on page 2* )

© BIS 2003

**BUREAU OF INDIAN STANDARDS**

This publication is protected under the *Indian Copyright Act* (XIV of 1957) and reproduction in whole or in part by any means except with written permission of the publisher shall be deemed to be an infringement of copyright under the said Act.

## IS : 1624 - 1986

( Continued from page 1 )

<i>Members</i>	<i>Representing</i>
HOUSING COMMISSIONER	Rajasthan Housing Board, Jaipur
RESIDENT ENGINEER ( <i>Alternate</i> )	
JOINT DIRECTOR RESEARCH (B&S)	Research, Designs and Standards Organization (Ministry of Railways), Lucknow
DEPUTY DIRECTOR RESEARCH (B&S) ( <i>Alternate</i> )	
SHRI N. MACEDO	Dyer's Stone Lime Co Pvt Ltd, Delhi
SHRI H. L. MARWAH	Builder's Association of India, Bombay
SHRI HARISH C. KOHLI ( <i>Alternate</i> )	
DR S. C. MAUDGAL	Department of Science & Technology, New Delhi
SHRI Y. R. PHULL	Central Road Research Institute (CSIR), New Delhi
SHRI M. L. BHATIA ( <i>Alternate</i> )	
DR A. V. R. RAO	National Buildings Organization, New Delhi
SHRI J. SEN GUPTA ( <i>Alternate</i> )	
SHRI M. V. NAGARAJ RAO	Public Works Department, Government of Madhya Pradesh, Bhopal
SHRI C. V. KAND ( <i>Alternate</i> )	
SHRI K. V. SINGH	Department of Mines & Geology, Government of Rajasthan, Udaipur
SHRI J. N. KACKER ( <i>Alternate</i> )	
SUPERINTENDING ENGINEER (PLANNING & DESIGN)	Public Works Department, Government of Tamil Nadu, Madras
EXECUTIVE ENGINEER (BUILDING CENTRE DIVISION) ( <i>Alternate</i> )	
SUPERINTENDING SURVEYOR OF WORKS (NDZ)	Central Public Works Department, New Delhi
SURVEYOR OF WORKS I (NDZ) ( <i>Alternate</i> )	
SHRI V. VASUDEVAN	Khadi & Village Industries Commission, New Delhi
SHRI E. RAMACHANDRAN ( <i>Alternate</i> )	
SHRI G. RAMAN, Director (Civ Engg)	Director General, ISI ( <i>Ex-officio Member</i> )
<i>Secretary</i>	
SHRI N. C. BANDYOPADHYAY Deputy Director (Civ Engg), ISI	

*Indian Standard*  
METHODS OF  
FIELD TESTING OF BUILDING LIME  
( *Second Revision* )

0. FOREWORD

**0.1** This Indian Standard (Second Revision) was adopted by the Indian Standards Institution on 30 June 1986, after the draft finalized by the Building Limes Sectional Committee had been approved by the Civil Engineering Division Council.

**0.2** Lime is a reactive material and constantly undergoes chemical changes on exposure to the atmosphere. Even during manufacture, there are chances of variability in the quality. It is, therefore, necessary to check its quality at various stages such as after burning, on slaking, during storage and before actual use. For this purpose, simple field tests can give quick and fairly reliable results. Only those field tests have been included in this standard which are fairly well established and have proved satisfactory. Although these are not as accurate as laboratory tests specified in IS : 6932 (Parts 1 to 11)\* which alone shall form the basis of acceptance or rejection for the purchase of material, field tests give a general idea of the quality of building lime and can be quite reliable if done in accordance with the specified procedure.

**0.2.1** This standard was first revised in 1974. Consequent upon the inclusion of additional variety of lime in IS : 712-1984†, this revision has been prepared to cover the field testing of all the varieties of lime. In this revision, all the methods have been modified in the light of experience gained during the use of this standard and a new method for testing workability has been incorporated.

**0.3** This edition 3.1 incorporates Amendment No. 1 (June 1991). Side bar indicates modification of the text as the result of incorporation of the amendment.

**0.4** In reporting the results of a test or analysis made in accordance with this standard, if the final value, observed or calculated, is to be rounded off, it shall be done in accordance with IS : 2-1960‡.

---

\*Methods of test for building limes (issued in 11 parts).

†Specification for building limes ( *third revision* ).

‡Rules for rounding off numerical values ( *revised* ).

## IS : 1624 - 1986

### 1. SCOPE

**1.1** This standard lays down the procedures of the following simple field tests for building lime:

- a) Visual examination,
- b) Hydrochloric acid test,
- c) Ball test,
- d) Impurity test,
- e) Plasticity test on blotting paper, and
- f) Workability test.

### 2. TERMINOLOGY

**2.1** For the purpose of this standard, the definitions given in IS : 6508-1972\* shall apply.

### 3. VISUAL EXAMINATION

**3.1 Procedure and Observation** — Examine the lime for colour and for state of aggregation, namely, lumpy, powdery, soft, hard, etc. Class C&D limes mostly used for whitewash have white colour. Lumpy form may indicate quick lime or unburnt limestone but the former may be differentiated by its porous structure. The hydrated lime supplied should not contain coarse and gritty lime pieces larger than about 2.50 mm when rubbed in between the thumb and the finger.

### 4. HYDROCHLORIC ACID TEST

**4.1 Procedure** — Place sufficient quantity of powder lime into a 50-ml graduated glass cylinder, which on gentle tapping for about two minutes or so, settles down to about 5-ml mark with a neat surface on the top. Into this cylinder, fill up to 25-ml mark hydrochloric acid (1 : 1), preferably along a glass rod placed in the cylinder so that the acid does not get smeared all over the side of the cylinder. The contents, after stirring with a glass rod, should not leave much inert material at the bottom of the cylinder. To ensure that the inert material left at the bottom of the cylinder after stirring with a glass rod, does not contain any calcium carbonate, add excess of hydrochloric acid drop by drop with constant stirring till there is no effervescence. The cylinder with its contents shall then be kept standing for about 24 hours for observation of gel formation.

---

\*Glossary of terms relating to building lime.

## 4.2 Observation

**4.2.1** If the effervescence indicating the liberation of carbon dioxide is abundant, it may be inferred that either the lime has a substantial proportion of calcium carbonate because it has not been burnt properly and adequately and/or stored properly. All acceptable lime will, however, give some effervescence.

**4.2.2** The volume of insoluble residue at the bottom of the cylinder compared with the original volume of lime will indicate the proportion of inert material and give an idea if it is excessive or not.

**4.2.3** In case of hydraulic lime, a good thick gel will be formed and below it some inert material will be deposited. If the gel is so thick, as not even to flow when the cylinder is turned upside down, the inference may be that the lime is of Class A. If the gel formed is not quite thick and tends to flow on being tilted, the lime may be class B or E. If there is no gel formation the lime may be Class C, D or F.

## 5. BALL TEST

**5.1 Procedure** — Make balls of about 50 mm diameter of quick lime mixed with just sufficient water to give a stiff paste, and leave them undisturbed for a period of six hours. Immerse in a basin of water.

**5.2 Observation** — Signs of disintegration within a few minutes show that time may be of Class C or D. Very little expansion and numerous cracks sometimes seen on the surface show that lime may be of Class B or E. No signs of disintegration under water show that lime may be of Class A.

## 6. IMPURITY TEST

**6.1 Procedure** — Draw a known mass of freshly burnt quick lime from the kiln or quick lime supplied and place in a vessel containing sufficient quantity of water. Stir the contents well and allow them to settle for two hours. Then pass the milk of lime with addition of water, if necessary, through 850 micron IS sieve. Wash the residue containing unburnt or overburnt stone, cinder, sand or any other impurity with clean water till it is free from lime. Transfer the residue to a metal tray with a jet of water.

Allow it to settle and decant off the water from the tray. Dry the residue, cool and screen out any fines which may have resulted due to slaking. Dry the residue for 8 hours in hot sun and weigh.

**6.2 Observation** — The extent of residue calculated as percentage of the initial mass of material gives an idea about the burning efficiency

## IS : 1624 - 1986

of the kiln or the presence of unreactive portions in the lime supplied as given below:

- a) Class B and F will have residue not more than 10 percent, and
- b) Class C and D will have residue not more than 5 percent.

NOTE — In rare cases, residue may be more than 10 percent in case of Class B lime.

### 7. PLASTICITY TEST ON BLOTTING PAPER

**7.1 Procedure** — Mix the lime with water to a thick cream like consistency and leave preferably overnight. Then, spread it like butter with the help of a knife on a blotting paper.

**7.2 Observation** — A comparison with the behaviour of performances of standard lime of known good quality with a little experience helps in judging its plasticity. If it is spreadable with ease without any gritty material and with soft strokes, then it may have good plasticity.

### 8. WORKABILITY TEST

**8.1** The two tests described in **8.1.1** and **8.1.2** may be used to evaluate the workability of lime.

#### **8.1.1** *Method 1*

**8.1.1.1** This procedure is largely a matter of judgement and is entirely left to the practical knowledge and experience of the mason or plasterer who uses the mortar. The test shall be performed on the same mortar as is subsequently required to be used in the construction. By throwing, with the same effort as for rough-cast work, a handful of the mortar on the surface on which it is to be used and by noting how much area is covered and how much mortar is picked up, the mason may be able to judge the workability. The spread of mortar on throw of a spadeful of mortar on trowel to the wall shall be at least double in size and greater part of it shall remain stuck to the wall for a good workability.

#### **8.1.2** *Method 2*

**8.1.2.1** For this test, frustum of cone and plate shown in Fig. 1 shall be used. Prepare the mortar as is subsequently required to be used in the construction. Fill the frustum of cone A with this mortar after placing the plate B in position under the cone. Gently tamp the mortar with a wooden rod (approximately 16 mm in diameter) and remove the excess mortar with a mason's trowel so that the mortar surface is in level with the top rim of the cone. Raise the cone along with the plate B to a height of 300 mm. Slide the plate B horizontally so that the mortar falls freely on the graduated plate C placed below horizontally on the

ground. Read the spread of the mortar on the plate and take the average. This spread shall be 150 to 160 mm for a good workable mortar.

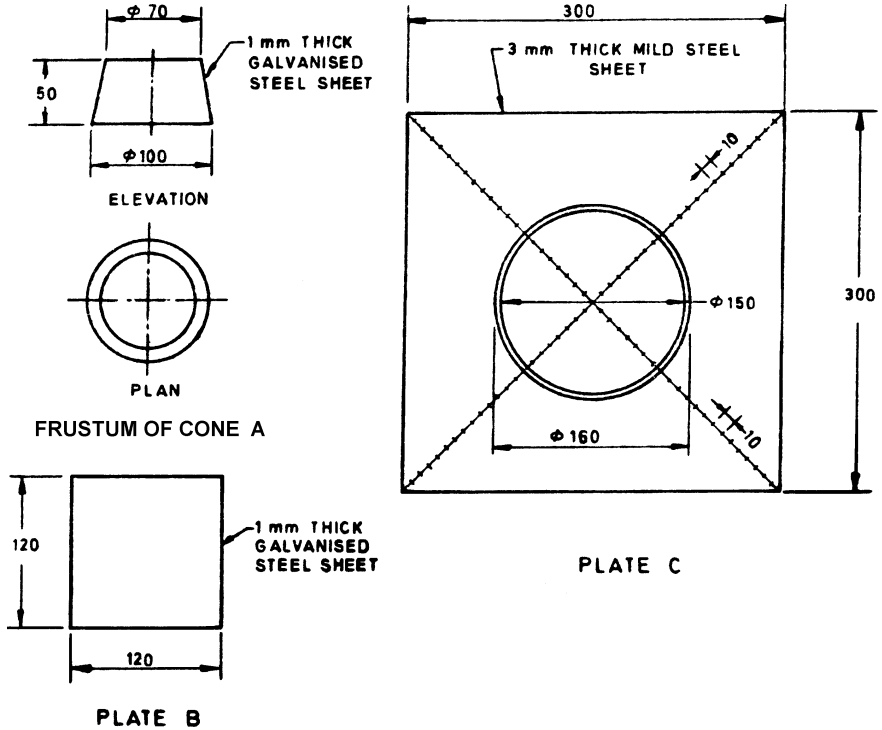

All dimensions in millimetres.

FIG. 1 CONE AND PLATES FOR WORKABILITY TEST



## **Bureau of Indian Standards**

BIS is a statutory institution established under the *Bureau of Indian Standards Act, 1986* to promote harmonious development of the activities of standardization, marking and quality certification of goods and attending to connected matters in the country.

### **Copyright**

BIS has the copyright of all its publications. No part of these publications may be reproduced in any form without the prior permission in writing of BIS. This does not preclude the free use, in the course of implementing the standard, of necessary details, such as symbols and sizes, type or grade designations. Enquiries relating to copyright be addressed to the Director (Publications), BIS.

### **Review of Indian Standards**

Amendments are issued to standards as the need arises on the basis of comments. Standards are also reviewed periodically; a standard along with amendments is reaffirmed when such review indicates that no changes are needed; if the review indicates that changes are needed, it is taken up for revision. Users of Indian Standards should ascertain that they are in possession of the latest amendments or edition by referring to the latest issue of 'BIS Catalogue' and 'Standards : Monthly Additions'.

This Indian Standard has been developed by Technical Committee : BDC 4

### **Amendments Issued Since Publication**

<b>Amend No.</b>	<b>Date of Issue</b>
Amd. No. 1	June 1991

## **BUREAU OF INDIAN STANDARDS**

Headquarters:

Manak Bhavan, 9 Bahadur Shah Zafar Marg, New Delhi 110002.  
Telephones: 323 01 31, 323 33 75, 323 94 02

Telegrams: Manaksanstha  
(Common to all offices)

Regional Offices:

	Telephone
Central : Manak Bhavan, 9 Bahadur Shah Zafar Marg NEW DELHI 110002	{ 323 76 17 323 38 41
Eastern : 1/14 C. I. T. Scheme VII M, V. I. P. Road, Kankurgachi KOLKATA 700054	{ 337 84 99, 337 85 61 337 86 26, 337 91 20
Northern : SCO 335-336, Sector 34-A, CHANDIGARH 160022	{ 60 38 43 60 20 25
Southern : C. I. T. Campus, IV Cross Road, CHENNAI 600113	{ 235 02 16, 235 04 42 235 15 19, 235 23 15
Western : Manakalaya, E9 MIDC, Marol, Andheri (East) MUMBAI 400093	{ 832 92 95, 832 78 58 832 78 91, 832 78 92
Branches : AHMEDABAD. BANGALORE. BHOPAL. BHUBANESHWAR. COIMBATORE. FARIDABAD. GHAZIABAD. GUWAHATI. HYDERABAD. JAIPUR. KANPUR. LUCKNOW. NAGPUR. NALAGARH. PATNA. PUNE. RAJKOT. THIRUVANANTHAPURAM. VISHAKHAPATNAM	