

भारतीय मानक  
अग्नि प्रतिरोधक इस्पात — विशिष्टि

*Indian Standard*  
FIRE RESISTANT STEEL — SPECIFICATION

ICS 13.220.50; 77.140.01

© BIS 2002

**BUREAU OF INDIAN STANDARDS**  
MANAK BHAVAN, 9 BAHADUR SHAH ZAFAR MARG  
NEW DELHI 110002

## FOREWORD

This Indian Standard was adopted by the Bureau of Indian Standards, after the draft finalized by the Wrought Steel Products Sectional Committee had been approved by the Metallurgical Engineering Division Council.

These steels find applications in those structural parts which are prone to fire and are subjected to fluctuation of stresses. Fire resistant properties are obtained by the incorporation of low proportions of alloying elements such as chromium and molybdenum.

For the purpose of deciding whether a particular requirement of this standard is complied with, the final value, observed or calculated, expressing the result of a test or analysis, shall be rounded off in accordance with IS 2 : 1960 'Rules for rounding off numerical values (*revised*)'. The number of significant places retained in the rounded off value should be the same as that of the specified value in this standard.

# Indian Standard

## FIRE RESISTANT STEEL — SPECIFICATION

### 1 SCOPE

This standard covers the requirements for fire resistant steel plates, strips, sections and bars, etc, for use in structural work up to a maximum temperature of 600°C for maximum duration of 3 h.

### 2 REFERENCES

The following Indian Standards contain provisions which through reference in this text, constitute provisions of this standard. At the time of publication, the editions indicated were valid. All standards are subject to revisions, and parties to agreements based on this standard are encouraged to investigate the possibility of applying the most recent editions of the standards indicated below:

<i>IS No.</i>	<i>Title</i>
228	Method for chemical analysis of steel
1599:1985	Method for bend test ( <i>second revision</i> )
1608:1995	Mechanical testing of metals — Tensile testing ( <i>second revision</i> )
1757:1988	Method for Charpy impact test ( V-notch ) for metallic material ( <i>second revision</i> )
1852:1985	Rolling and cutting tolerances for hot-rolled steel products ( <i>third revision</i> )
1956	Glossary of terms relating to iron and steel
8910:1978	General technical delivery requirements for steel and steel products

### 3 TERMINOLOGY

For the purpose of this standard, the following definitions in addition to those given in the relevant parts of IS 1956 shall apply.

#### 3.1 Micro-Alloying Elements

Elements, such as niobium, vanadium and titanium, added singly or in combination to obtain higher strength levels combined with better formability, weldability and toughness as compared with non-alloyed steel produced to equivalent strength levels.

### 4 SUPPLY OF MATERIAL

General requirements relating to the supply of steel shall conform to IS 8910.

### 5 MANUFACTURE

The process used for making the steel and in manufacturing hot rolled steel plates, strips, sections, flats, bars, etc, are left to the discretion of the manufacturer. If required secondary refining may follow steel making.

### 6 GRADES

There shall be two grades of structural fire resistant steel as given in Tables 1 and 3.

### 7 CHEMICAL COMPOSITION

7.1 Ladle analysis of the steel, when carried out by the method specified in the relevant parts of IS 228 or any other established instrumental/chemical method, shall be as specified in Table 1. In case of any dispute, the procedure given in the relevant part of IS 228 shall be the reference method. However, if the method is not given in any part of IS 228, the reference method shall be as agreed to between the purchaser and the manufacturer.

#### 7.2 Product Analysis

The product analysis shall be carried out on the finished product from the standard position. Permissible variation in case of such product analysis from the limits specified under 7.1 shall be as given in Table 2.

### 8 WELDABILITY

8.1 All steel grades specified in this standard are of weldable quality. If agreed to between the manufacturer and the purchaser, the fire resistant steel up to and including 50 mm thick plates shall be supplied with a carbon equivalent value of 0.54 *Max* based upon the ladle analysis. The carbon equivalent may be calculated using the following formula:

Carbon equivalent ( CE ) =

$$\%C + \frac{\%Mn}{6} + \frac{\%Cr + \%Mo + \%V}{5} + \frac{\%Cu + \%Ni}{15}$$

**Table 1 Chemical Composition**  
( Clauses 6 and 7.1 )

Grade	Designation	Ladle Analysis, Percent, Max						
		C	Si	Mn	P	S	Cr	Mo
(1)	(2)	(3)	(4)	(5)	(6)	(7)	(8)	(9)
A	FR-Fe 410	0.20	0.40	1.30	0.04	0.04	0.55	0.25-0.35
B	FR-Fe 490	0.20	0.50	1.50	0.04	0.04	0.55	0.25-0.45

## NOTES

- 1 The grades shall contain sufficient aluminium to tie up free nitrogen.
- 2 If necessary, microalloying elements Nb, V, Ti may be added. In such case the total content of all microalloying elements shall not exceed 0.15 percent.
- 3 The material may be supplied in the copper bearing quality in which case the copper shall be between 0.20 and 0.35 percent on analysis.

**Table 2 Permissible Variations for Products Analysis**  
( Clause 7.2 )

Constituent	Variation Over/Under the Specified Limit, Percent, Max
(1)	(2)
C	0.02
Si	0.03
Mn	0.05
P	0.005
S	0.005
Cr	0.05
Mo	0.05

**8.2** If the fire resistant steels are used where during a fire the maximum temperature of the steel part exceeds 350°C it is advisable to select welding electrodes with matching elevated temperature yield strength.

**8.3** Lower limit for carbon equivalent values may be agreed to between the purchaser and the manufacturer.

**8.4** Higher limit of plate thickness may be agreed to between the purchaser and the manufacturer.

## 9 SELECTION AND PREPARATION OF TEST SAMPLES

**9.1** The position from which test samples are taken shall be so located in the product as to yield the clearest possible information regarding properties in the cross-sectional and longitudinal planes. The recommended locations for taking test samples for plates, sections and bars are indicated in Fig. 1. Alternatively, in case of sections, the samples may be taken from the web.

**9.2** Whenever practicable, the rolled surface of the

steel shall be retained on the two opposite sides of the test samples.

**9.3** In case of flat test samples for tensile test, both surfaces are normally to be left on the test samples for strips and plates up to 32 mm thick. At least one rolled surface shall be left on rectangular test samples taken from plates exceeding 32 mm in thickness. Round test samples are permitted, but should only be adopted for thickness exceeding 28 mm.

**9.4** In case of flats up to 16 mm thick, the test sample shall undergo, if possible, no machining whatever, prior to use as a test piece. If this is not possible, the test sample shall undergo the minimum amount of machining.

**9.5** Bars below 28 mm shall be tested without machining. In case of bars having diameters or thickness between 28 mm and 71 mm, the bars may be symmetrically reduced by machining. For bars having diameters or thicknesses exceeding 71 mm, the test sample may be taken from the position shown in Fig. 1.

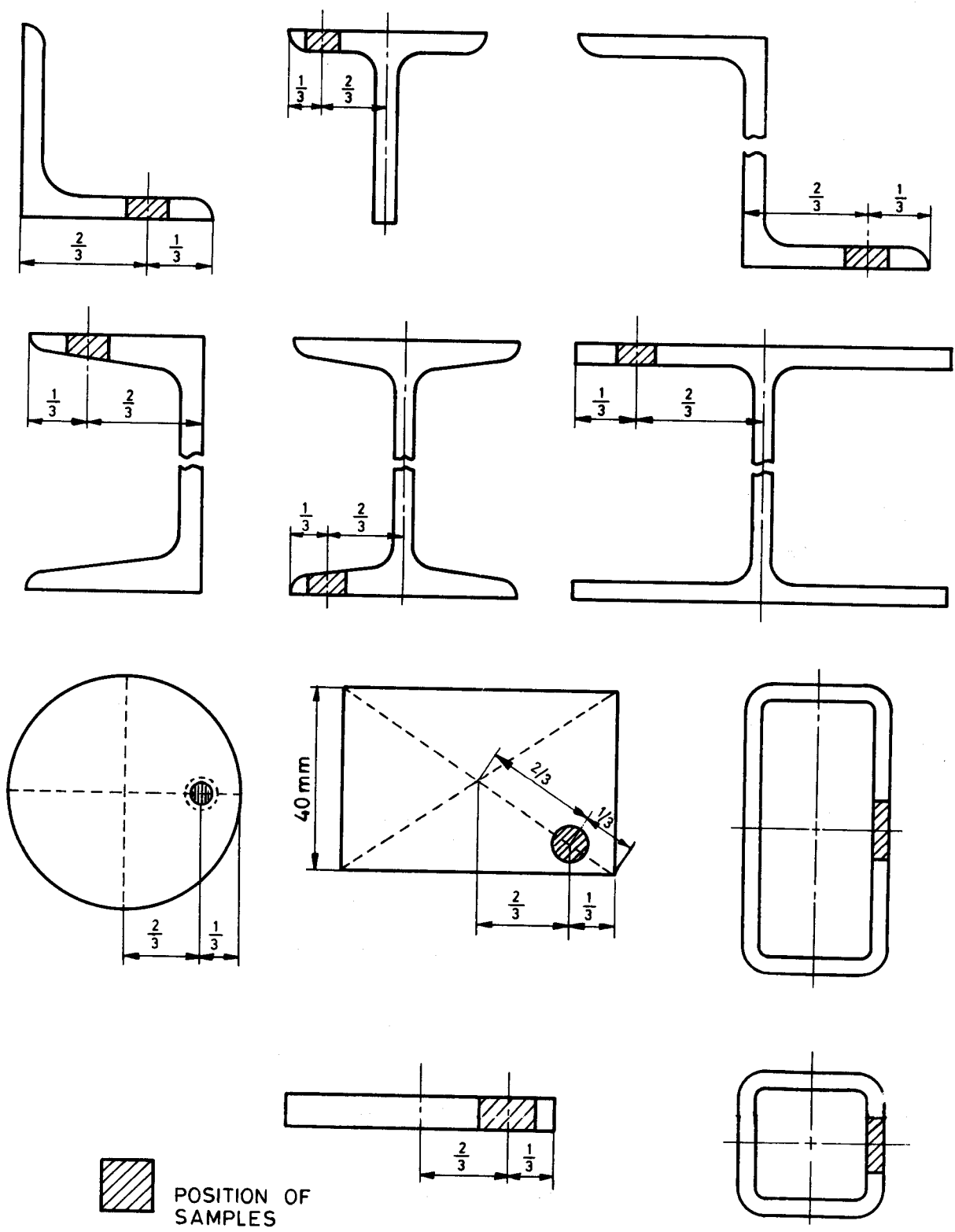

FIG. 1 FIRE RESISTANT STRUCTURAL STEEL SECTIONS, POSITION AND ORIENTATION OF SAMPLES

9.6 In case of plates, strips, sections and flats, bend tests shall be carried out on rectangular test sample, which, as far as possible, should be of the full thickness of the product. In case of plates, sections and flats exceeding 28 mm in thickness, it is permissible to remove metal from one side of the test sample before using it as a test piece. The rolled surface of the test piece shall be on the outer side of the bend during the test.

9.7 Before test sample are detached, full particulars regarding cast number, size and mass of plates, strips, sections flats and bars in each cast shall be furnished by the manufacturer to the purchaser. In case of plates, the number of plates in each cast shall also be given.

9.8 Test samples shall be cut in such a manner that the deformation is avoided as far as possible. If shearing or flame cutting is employed, an adequate allowance shall be left for removal by machining.

9.9 Test samples shall not be subjected to heat treatment unless the material from which they are cut is similarly treated, in which case the test samples shall be similarly and simultaneously treated with the material before testing. Any slight straightening of test samples which may be required shall be done cold.

## 10 TENSILE TEST

### 10.1 Number of Tensile Tests

#### 10.1.1 Plates, Strips, Sections (Angles, Tees, Beams, Channels, etc) and Flats

One tensile test at ambient temperature and one at 600°C, shall be carried out on the finished steel for every 100 tonnes or part thereof rolled continuously from each cast. A separate test shall be carried out for each class of steel product (namely, plates, strips sections and flats) rolled from a cast.

10.1.1.1 Where plates, strips, sections or flats of more than one thickness are rolled from the same cast, one additional set of tensile tests shall be made from the material in each class of product for each variation in thickness of 6 mm.

### 10.1.2 Bars (Round, Square and Hexagonal)

One tensile test shall be carried out from finished steel for every heat or 100 tonnes whichever is less, rolled continuously from each cast and for every class of product. When more than one diameter or thickness of the bar is specified, one additional tensile test shall be made for each diameter or thickness of the bar ordered, if so desired, by the purchaser.

## 10.2 Tensile Test Pieces

The tensile strength, yield strength and percentage elongation of steel shall be determined from standard test pieces cut lengthwise or crosswise from plates and lengthwise from sections, flats and bars. The tests shall be carried out on test pieces prepared in accordance with IS 1608.

10.2.1 As a rule, test pieces with a proportional gauge length complying with the requirements  $L_0 = 5.65 \sqrt{S_0}$  should be used for the tensile test, where  $L_0$  is the gauge length and  $S_0$  is the cross sectional area of the test piece.

10.2.1.1 Test pieces with a non-proportional gauge lengths, other than  $5.65 \sqrt{S_0}$ , may be used in which case the elongation values shall be converted to  $5.65 \sqrt{S_0}$  in accordance with IS 3803 (Part 1).

10.3 The tensile strength, yield strength and percentage elongation, when determined in accordance with IS 1608 shall be as given in Table 3.

10.3.1 In case of sections, the thickness of which is not uniform throughout the profile, the limits of sizes given in Table 3 shall be applied according to the actual maximum thickness of the piece selected for testing.

10.3.2 Should the tensile test piece break outside the middle half of its gauge length (see IS 1608) and the percentage elongation obtained is less than that specified, the test may be discarded at the manufacturer's option, and another test made from the same plate, strip, section, flat or bar.

**Table 3 Mechanical Properties at Ambient Temperature**

(Clauses 6 and 10.3)

Grade	Designation	Tensile Strength MPa Min	Yield Strength, MPa, Min				Percentage Elongation at Gauge Length $5.65\sqrt{S_0}$ Min
			< 12	12-25	25-40	> 40	
(1)	(2)	(3)	(4)	(5)	(6)	(7)	(8)
A	FR-Fe 410	410	300	280	260	240	21
B	FR-Fe 490	490	350	330	310	290	18

NOTE — The yield strength at 600°C shall be not less than two-thirds of yield stress given in the table.

## 11 BEND TEST

### 11.1 Number of Bend Tests

Bend test shall be made from finished steel from each cast. The number of tests for every 50 tonnes of material, or part thereof, rolled continuously shall be as given below. One additional test shall be made for each class of product and for each variation in thickness.

<i>Class of Steel Product</i>	<i>Number of Bend Test Pieces</i>
Section	One lengthwise for each type
Plates	One lengthwise and/or one crosswise
Flats, strips and bars	One lengthwise

### 11.2 Bend Test Pieces

The test pieces shall be cut lengthwise or crosswise or both from plates and lengthwise from sections, flats and bars. When sections permit, these shall be not less than 40 mm wide. If the manufacturer so desires, round, square, hexagonal and flat bars shall be bent in the full sections as rolled.

**11.2.1** In all bend test pieces, the rough edge or arisings resulting from shearing may be removed by filling or grinding or machining but the test pieces shall receive no other preparation.

**11.2.2** The test pieces shall not be annealed or otherwise subjected to heat treatment unless the material from which they are cut is similarly treated in which case the test pieces shall be similarly treated with the material before testing.

### 11.3 Bend Test

Bend test shall be conducted in accordance with IS 1599.

**11.3.1** For bend tests except in the case of round bars 25 mm in diameter and under, the test pieces when cold shall without cracking, be doubled over either by pressure or by blows from a hammer until the internal diameter is not greater than three times the thickness of the test piece and the sides are parallel.

**11.3.2** In the case of round bars 25 mm in diameter and under the internal diameter of the bend shall be not greater than twice the diameter of the bar.

## 12 IMPACT TEST

**12.1** The impact tests shall normally be carried out on products having a thickness greater than or equal to 12 mm. The test piece shall be so machined that the face closest to the rolling surface is not more than

1 mm from it. The notch shall be perpendicular to the rolled surface. One sample for impact test shall be made from finished steel for every 50 tonnes or part thereof rolled continuously from each cast.

**12.1.1** The test piece shall be taken at one-fourth of the thickness for the product above 40 mm thick.

**12.1.2** If stated on the order, impact tests may be carried out on products having a thickness less than 12 mm. The dimensions of the test pieces shall be in conformity with IS 1757.

**12.2** The test samples shall be taken from thickness product.

**12.3** This test is carried out using a V-notch test piece ( *see* IS 1757 ) the value for consideration being the arithmetic mean of the results obtained on three test pieces taken side by side in the same product. This mean value shall not be less than 27 Joules at 0°C.

**12.3.1** Values for thickness over 16 mm are subject to mutual agreement between the purchaser and the manufacturer.

**12.3.2** The average value for acceptance shall be considered only if not more than one specimen exhibits a value below the specified minimum average and in no case shall an individual value be below two-thirds of the specified minimum average.

**12.3.3** If more than one specimen are below the specified minimum average, and if one value is below two-thirds the specified minimum average and in no case shall an individual value be below two-thirds of the specified minimum average.

## 13 FREEDOM FROM DEFECTS

**13.1** All finished steel shall be well and cleanly rolled to dimensions, sections and mass specified. The finished material shall be free from cracks, surface flaws, laminations, rough jagged and imperfect edges and all other harmful defects.

**13.2** Minor surface defects may be removed by the manufacturer by grinding provided that the thickness is not reduced locally by more than 4 percent ( with a maximum of 3 mm ). Reductions greater than 4 percent but not exceeding 7 percent may be made subject to mutual agreement between the purchaser and the manufacturer.

**13.2.1** Subject to agreement with the purchaser, surface defects which cannot be dealt with as in 13.2 may be repaired by chipping for grinding followed by welding.

**13.2.1.1** The tolerance of the chipped or ground surface of any piece prior to welding shall not exceed 2 percent of total surface area of that piece.

**13.2.1.2** The flange of angles, beams and channel sections and the web and flanges of tee-sections may be conditioned by grinding, chipping or arc-air gouging and welding. Prior to welding the depth of depression, measured from the toe inward, shall be limited to the thickness of the material at the base of the depression with a maximum depth limit of 13 mm.

**13.2.1.3** The edges of plates may be conditioned by the manufacturer to remove injurious imperfections by grinding, chipping or arc-air gouging and welding. Prior to welding, the depth of depression measured from the plate edge inward shall be limited to the thickness of the plate with a maximum depth of 25 mm.

**13.2.1.4** The reduction of sectional dimensions of a round, square or hexagon bar, or the reduction in thickness of a flat bar, resulting from removal of an imperfection prior to welding shall not exceed 5 percent of the nominal dimension or thickness at the location of the imperfection.

#### 14 DIMENSIONS AND TOLERANCES

**14.1** Unless otherwise agreed to between the purchaser and the manufacturer, the nominal dimensions of the rolled steel products conforming to this Standard shall be in accordance with the relevant Indian Standards. Currently available Indian Standards are listed in Table 4.

**14.2** Unless otherwise agreed to between the purchaser and the manufacturer, the rolling and cutting tolerances for steel products conforming to this standard shall be those specified in IS 1852.

#### 15 RETESTS

Should any one of the test pieces first selected fail to pass any of the tests specified in 9, 10, 11 and 12 two further samples shall be selected for testing in respect of each failure. Should the test pieces from both these additional samples pass the material represented by the test samples shall be deemed to comply with the requirements of the particular test. Should the test pieces from either of these additional samples fail, the material represented by the test samples shall be considered as not having complied with this standard.

#### 16 CALCULATION OF MASS

The mass of steel shall be calculated on the basis that steel weighs  $7.85 \text{ gm/cm}^3$ .

#### 17 DELIVERY

Subject to prior agreement between the purchaser and the manufacturer, suitable protective treatment may be given to the material after rolling.

#### 18 MARKING

**18.1** Each product, except round, square and hexagonal bars and flats shall be stamped with the manufacturer's name or trade-mark. In the case of bars and flats each bundle shall carry a tag and the tag shall bear the manufacturer's name or trade-mark. Designation of steel shall also be similarly marked on the product or tags.

**Table 4 Indian Standards Which Give Nominal Dimensions of Rolled Steel Products**  
( Clause 14.1 )

Product (1)	Relevant Indian Standards (2)
Beam, column, channel angle sections	808 : 1989 Dimension for hot rolled steel beam, and column, channel and angle sections ( <i>third revision</i> )
Tee bars	1173 : 1978 Hot rolled and slit steel tee bars
Bulb angles	1252 : 1958 Rolled steel section bulb angle
Plates, strips and flats	1730 : 1989 Dimensions of steel plates sheets, strips and flats for structural and general engineering purposes ( <i>second revision</i> )
Round and square bars	1732 : 1971 Dimensions for round and square steel bars for structural and general engineering purposes
Bulb flats	1863 : 1979 Rolled steel bulb flats
Sheet piling sections	2314 : 1963 Steel sheet piling sections
Channel sections	3954 : 1966 Hot rolled steel channel sections for general engineering purposes
Hollow section	4923 : 1968 Hollow steel sections for structural use
Hull plates	5488 : 1969 Dimensions for hot rolled steel plates for ship's hull structure



**18.2** Every heavy and medium structural mill product every coil or strip and each plate of thickness 10 mm and over shall be stamped/marked with the cast number and manufacturer's name or trade-mark. In case of plates below 10 mm thickness, the top plate of each pile ( which may consist of approximately 10 plates ) shall be marked with the cast number.

**18.3** The ends of the rolled products shall be suitably painted with a colour code as given below:

<i>Grade A</i>	Blue
<i>Grade B</i>	Red

**18.4** The material may also be marked with the Standard Mark.

**18.4.1** The use of Standard Mark is governed by the provisions of *Bureau of Indian Standards Act, 1986* and the Rules and Regulations made thereunder. The details of conditions under which the licence for the use of Standard Mark may be granted to manufacturers or producers may be obtained from Bureau of Indian Standards.

## Bureau of Indian Standards

BIS is a statutory institution established under the *Bureau of Indian Standards Act, 1986* to promote harmonious development of the activities of standardization, marking and quality certification of goods and attending to connected matters in the country.

### Copyright

BIS has the copyright of all its publications. No part of these publications may be reproduced in any form without the prior permission in writing of BIS. This does not preclude the free use, in the course of implementing the standard, of necessary details, such as symbols and sizes, type or grade designations. Enquiries relating to copyright be addressed to the Director (Publications), BIS.

### Review of Indian Standards

Amendments are issued to standards as the need arises on the basis of comments. Standards are also reviewed periodically; a standard along with amendments is reaffirmed when such review indicates that no changes are needed; if the review indicates that changes are needed, it is taken up for revision. Users of Indian Standards should ascertain that they are in possession of the latest amendments or edition by referring to the latest issue of 'BIS Catalogue' and 'Standards : Monthly Additions'

This Indian Standard has been developed from Doc : No. MTD 4 (4329).

### Amendments Issued Since Publication

Amend No.	Date of Issue	Text Affected

## BUREAU OF INDIAN STANDARDS

### Headquarters:

Manak Bhavan, 9 Bahadur Shah Zafar Marg, New Delhi 110 002  
Telephones : 323 01 31, 323 33 75, 323 94 02

Telegrams: Manaksanstha  
( Common to all offices )

### Regional Offices :

Central : Manak Bhavan, 9 Bahadur Shah Zafar Marg  
NEW DELHI 110 002

Telephone  
{ 323 76 17  
{ 323 38 41

Eastern : 1/14 C. I. T. Scheme VII M, V. I. P. Road, Kankurgachi  
KOLKATA 700 054

{ 337 84 99, 337 85 61  
{ 337 86 26, 337 91 20

Northern : SCO 335-336, Sector 34-A, CHANDIGARH 160 022

{ 60 38 43  
{ 60 20 25

Southern : C. I. T. Campus, IV Cross Road, CHENNAI 600 113

{ 254 12 16, 254 14 42  
{ 254 25 19, 254 13 15

Western : Manakalaya, E9 MIDC, Marol, Andheri (East)  
MUMBAI 400 093

{ 832 92 95, 832 78 58  
{ 832 78 91, 832 78 92

Branches : AHMADABAD. BANGALORE. BHOPAL. BHUBANESHWAR. COIMBATORE.  
FARIDABAD. GHAZIABAD. GUWAHATI. HYDERABAD. JAIPUR. KANPUR.  
LUCKNOW. NAGPUR. NALAGARH. PATNA. PUNE. RAJKOT. THIRUVANANTHAPURAM.