

भारतीय मानक

फाइबर प्रबलित सीमेंट के उत्पाद —  
छत व क्लैडिंग के लिए लम्बी नालीदार या असमान  
काट की चादरें — विशिष्टि

*Indian Standard*

PRODUCTS IN FIBRE REINFORCED CEMENT —  
LONG CORRUGATED OR ASYMMETRICAL  
SECTION SHEETS AND FITTINGS FOR  
ROOFING AND CLADDING — SPECIFICATION

ICS 91.100.40

© BIS 2000

**BUREAU OF INDIAN STANDARDS**  
MANAK BHAVAN, 9 BAHADUR SHAH ZAFAR MARG  
NEW DELHI 110002

## FOREWORD

This Indian Standard was adopted by the Bureau of Indian Standards, after the draft finalized by the Cement Matrix Products Sectional Committee had been approved by the Civil Engineering Division Council.

This standard has been formulated to fulfill the need for a specification of non asbestos fibre cement flat sheets. Specially formulated and treated synthetic organic fibres and cellulose fibres have been used in practices for the manufacture of this product.

In the formulation of this standard, due weightage has also been given to the international coordination among the standards and practices in different countries in addition to relating it to the practices in the field in this country. This has been achieved by deriving assistance from:

- a) ISO 9933 : 1995 Products in fibre-reinforced cement — Long corrugated or asymmetrical section sheets and fittings for roofing and cladding, International Organization for Standardization
- b) ISO 390 : 1993 Products in fibre-reinforced cement — Sampling and inspection, International Organization for Standardization.

The composition of the technical committee responsible for formulation of this standard is given at Annex E.

For the purpose of deciding whether a particular requirement of this standard is complied with, the final value, observed or calculated, expressing the result of a test shall be rounded off in accordance with IS 2 : 1960 'Rules for rounding off numerical values (*revised*)'. The number of significant places retained in the rounded off value should be the same as that of the specified value in this standard.

## Indian Standard

# PRODUCTS IN FIBRE REINFORCED CEMENT — LONG CORRUGATED OR ASYMMETRICAL SECTION SHEETS AND FITTINGS FOR ROOFING AND CLADDING — SPECIFICATION

### 1 SCOPE

**1.1** This standard covers the requirements for straight fibre cement profiled sheets of more than 0.9 m length, and their fittings used as roofing and cladding materials. It also specifies tests for checking these characteristics as well as marking and conditions for acceptance.

**1.2** Some of these requirements may apply, after agreement between the manufacturer and the purchaser, to curved corrugated sheets.

**1.3** This standard does not apply to asbestos cement profiled sheets which are covered by IS 459.

### 2 REFERENCES

The Indian Standards given in Annex A contain provisions which, through reference in this text, constitute provisions of this standard. At the time of publication, the editions indicated were valid. All standards are subject to revision, and parties to agreements based on this standard are encouraged to investigate the possibility of applying the most recent editions of the standards indicated in Annex A.

### 3 TERMINOLOGY

For the purpose of this standard, the following definitions shall apply.

**3.1 Acceptance Test** — Test to establish whether a batch of products conforms to a specification. The tests are performed on samples drawn either from continuous production or from a consignment.

**3.2 Type Test** — Test concerned with the approval of a new product and/or a fundamental change in formulation and/or method of manufacture from which the effects cannot be predicted on the basis of previous experience.

The test is performed on the as-delivered product. The test is required to demonstrate conformity of a generic product to a specification.

**3.3 Acceptable Quality Level (AQL)** — When a continuous series of lots are considered, the quality

level which for the purposes of sampling inspection is the limit of a satisfactory process average<sup>1)</sup>

**3.4 As-Delivered** — In the same condition as the producer intends to supply the product after completing all aspects of the process including maturing and when appropriate, painting.

### 3.5 Fibres

- a) Discrete elements randomly dispersed,
- b) Continuous strands and tapes, and
- c) Nets or webs.

**3.6 Breaking Load** — Maximum load achieved during the bending test and representing the load-bearing capacity of the sheets at the test span.

### 4 SYMBOLS, ABBREVIATIONS AND UNITS

For the purpose of this standard the following letter symbols shall have the meaning indicated against each, where other symbols are used, they are explained at the appropriate place.

$a$	— Pitch of the corrugation, in mm
$e, e_1, e_2$	— Thickness of the sheet, in mm
$f$	— Deflection, in mm, in the breaking load test
$f_{0.2}$	— Deflection, in mm, at 20 percent of the specified load in the breaking load test
$f_{0.7}$	— Deflection, in mm, at 70 percent of the specified load in the breaking load test
$f_t$	— $f_{0.7} - f_{0.2}$ , in mm
$h$	— Height of the corrugation, in mm
$h_{od}$	— Height of the edge of the descending corrugation at edge, in mm
$h_{om}$	— Height of the edge of ascending corrugation at edge, in mm
$L$	— Ratio of the estimation $l_1$ to $l_s$
$L_1$	— Upper estimation at 95 percent confidence level of the result $M_1$ in the warm water test
$L_s$	— Lower estimation at 95 percent confidence level of the result $M_2$ in the warm water test
$l_1, l_2, l_3$	— Lengths of the sheet, in mm
$l$	— Clear span, in mm, between the supports in the breaking bending moment test

<sup>1)</sup>A sampling scheme with an AQL of 4 percent means that batches containing up to 4 percent defective items have a high probability of acceptance.

- $W_1, W_2$  — Widths of the sheet, in mm
- $W_3$
- $M_1$  — Average value of the test result of the control specimen of the first lot for the warm water test
- $M_2$  — Average value of the test result of the specimens after the warm water test
- $m$  — Mass of the specimen, in g, after drying when determining the apparent density
- $P$  — Breaking load, in N, for the bending moment test
- $P_c$  — Breaking load per metre width, in N/m
- $s_1$  — Standard deviation of the specimens with average  $M_1$
- $s_2$  — Standard deviation of the specimens with average  $M_2$
- $V$  — Apparent volume, in  $\text{cm}^3$ , of the specimens for the apparent density test
- $W$  — Width of the sheet for the breaking load test in m
- $W_e$  — Effective width
- $\rho$  — Apparent density of specimen, in  $\text{g/cm}^3$

**5 SHEETS**

**5.1 General Composition**

The product shall be composed essentially of an inorganic hydraulic binder (*see* Note) or a calcium silicate binder formed by the chemical reaction of a siliceous (includes ground silica, pulverized fuel ash and amorphous silica) and calcareous material reinforced by organic fibres and/or inorganic synthetic fibres. Pozzolanic materials, process aids, fillers and

pigments which are compatible with the fibre reinforced cement may be added. The inorganic hydraulic binder shall be either 33 grade ordinary Portland cement conforming to IS 269 or 43 grade ordinary Portland cement conforming to IS 8112 or 53 grade ordinary Portland cement conforming to IS 12269 or Portland pozzolana (fly ash based) cement conforming to IS 1489 (Part 1) or Portland pozzolana cement (calcined clay based) conforming to IS 1489 (Part 2) or rapid hardening cement conforming to IS 8041 or Portland slag cement conforming to IS 455. Fly ash used shall be conforming to IS 3812.

NOTE — In case of Portland pozzolana cement and Portland slag cement, addition of pozzolanic materials and slag shall not be permitted.

**5.2 General Appearance and Finish**

The surface of the sheets intended to be exposed to the weather shall be generally of smooth finish. Variations of the surface appearance, due to the method of manufacture, which do not impair the strength or performance of the sheets, are permitted.

The sheets may be left with their natural colour or colouring matter may be added in the composition. They may also receive adherent coloured or uncoloured coating in their either side surfaces.

**5.3 Classification**

**5.3.1 According to Nominal Height of Corrugations**

The sheets shall be of categories based on height of their corrugations,  $h$  (*see* Fig. 1) and minimum thickness,  $e$  in accordance with Table 1.

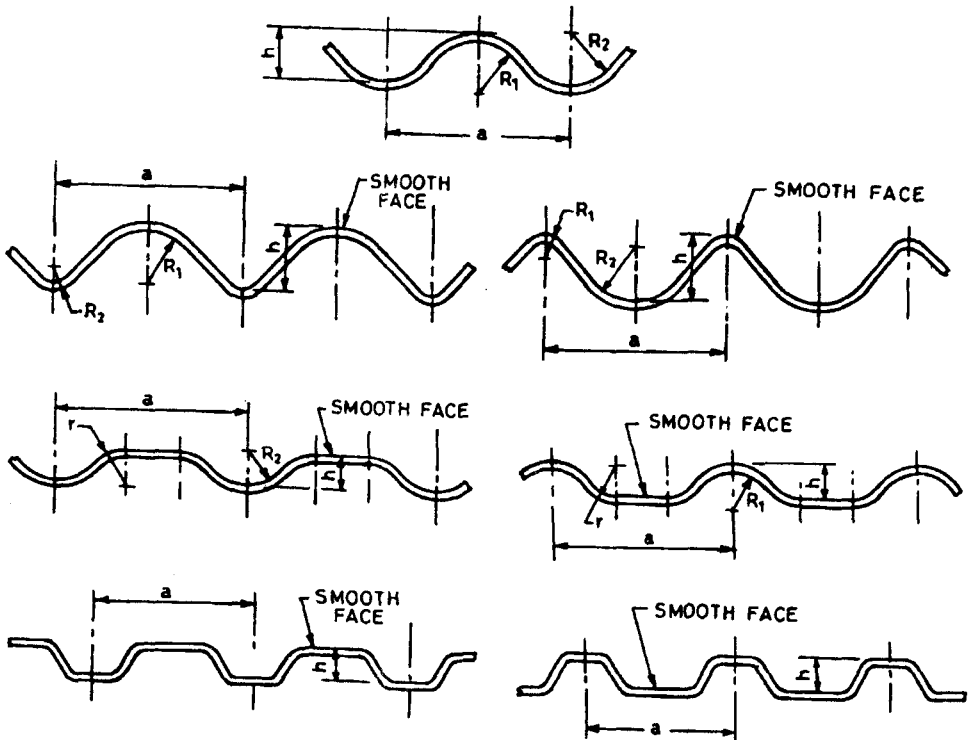

FIG. 1 GENERAL PROFILES OF LONG CORRUGATED OR ASYMMETRICAL SECTION SHEETS

**Table 1 Category and Class (Minimum Breaking Load in N/m)**  
(Clauses 5.3.1, 5.3.3, C-1.2.1 and C-4)

Category	Minimum Thickness, $e$ , mm	Class									
		1	2	3	4	5	6	7	8	9	10
A ( $15 \text{ mm} \leq h \leq 55 \text{ mm}$ )	3	600	800	1 000	1 400	—	—	—	—	—	—
B ( $25 \text{ mm} \leq h \leq 55 \text{ mm}$ )	4	—	—	1 000	1 400	2 000	2 500	3 300	—	—	—
C ( $40 \text{ mm} \leq h \leq 80 \text{ mm}$ )	4.5	—	—	—	1 400	2 000	2 500	3 300	4 250	—	—
D ( $60 \text{ mm} \leq h \leq 150 \text{ mm}$ )	5.5	—	—	—	—	—	—	3 300	4 250	5 600	7 400

NOTE — The sheets being commonly manufactured in India at the time of formulation of this standard fall under Category B and C and Class 7.

### 5.3.2 According to Thickness

*Type A*—The thickness of the sheets shall be approximately constant throughout the width of profile (see Fig. 2).

*Type B*—The thickness of the sheets shall vary regularly between the valley and the crown for corrugated sheets or between the lower part and the upper part of ribs for asymmetrical section sheets, in the same cross-section (see Fig. 2).

### 5.3.3 According to Minimum Breaking Load in Bending

For each category of sheet the minimum breaking load requirement shall be as given in Table 1.

## 5.4 Characteristics

### 5.4.1 Dimensions

Within the provisions of this standard, the nominal dimensions shall be declared by the manufacturer.

Standard dimensions for corrugated sheet shall include length, overall width, effective nominal thickness of sheet, and depth and pitch of corrugations. The profile and other dimensions shall be tested in accordance with Annex B.

#### 5.4.1.1 Width

The width shall be the arithmetic average of  $W_1$ ,  $W_2$  and  $W_3$  as shown in Fig. 3.

#### 5.4.1.2 Thickness

Each individual thickness measured according to B-3 shall not be less than the values given in Table 1.

#### 5.4.1.3 Number of corrugations

The number of corrugations to be considered for designation shall be the number of complete corrugations of the sheet.

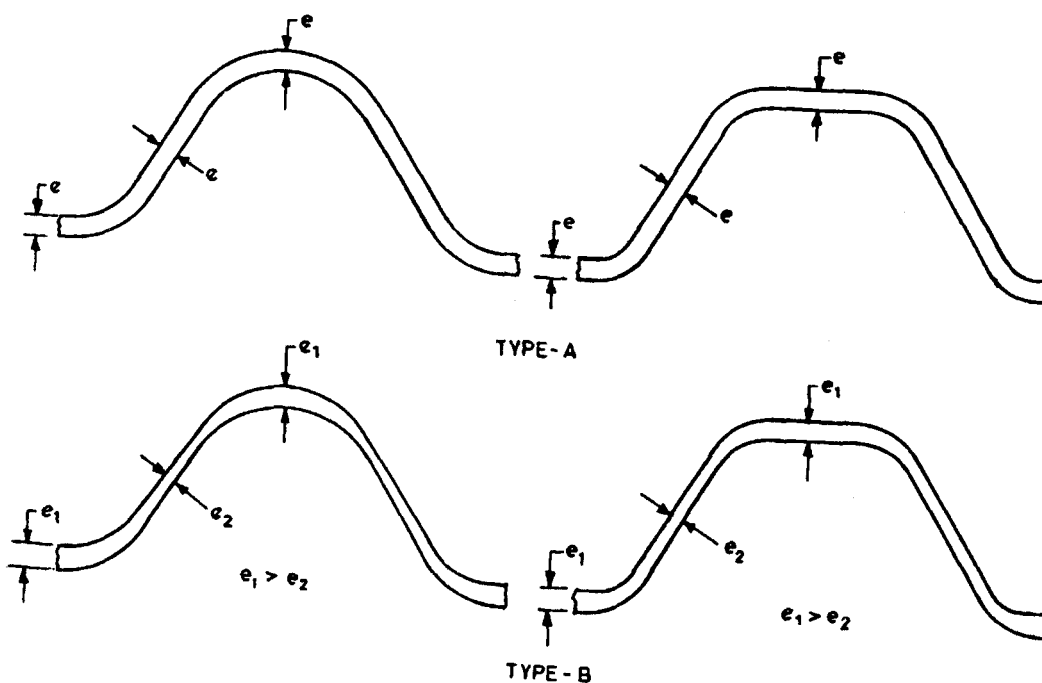

FIG. 2 PROFILES WITH CONSTANT AND VARYING THICKNESS

180 mm < a ≤ 260 mm	+8.0 - 3.0 mm
260 mm < a	+9.0 - 3.0 mm

Tolerance for pitch of corrugation relates to measurement over extreme corrugation.

- b) Tolerance on height of corrugation,  $h$  :
- |                      |               |
|----------------------|---------------|
| 15 mm ≤ $h$ ≤ 45 mm  | ± 2 mm        |
| 45 mm ≤ $h$ ≤ 150 mm | + 3<br>- 5 mm |
- c) Tolerances on length ± 10 mm
- d) Tolerances on overall Width and effective width,  $W_e$  ± 10  
- 5 mm
- e) Tolerance on nominal thickness,  $e$ : ± 10 percent but not more than ±0.6 mm of the nominal thickness.
- f) Out of squareness of sheets: less than 10 mm.
- g) Tolerance on height of edges: The producer shall specify this tolerance in their literature when it is necessary to ensure the weather tightness of the roof, only for sheets having an ascending edge one side and a descending edge on the other side.

#### 5.4.2.2 Deflection

When tested in accordance with Annex C, the increase in deflection  $f_i$ , between applying 20 percent ( $f_{0.2}$ ) and 70 percent ( $f_{0.7}$ ) of the load specifying the class shall not exceed the conventional value,  $f$  given by the following equation :

$$f = 0.7 \times 10^{-3} \times \frac{l_2}{h}$$

$$f_i = f_{0.7} - f_{0.2}$$

#### 5.4.3 Physical Characteristics

With the exception of 5.4.3.3, these characteristics shall be determined on products as-delivered wherever practical. The results are identified as applying to coated or uncoated materials. Failure of the coating does not constitute failure of the product.

##### 5.4.3.1 Impermeability

When tested in accordance with Annex D, traces of moisture may appear on the under face of the sheet but in no instance shall there be any formation of water drops during 24 h of the test.

##### 5.4.3.2 Frost resistance

Sheets for frost resistant application, shall be tested in accordance with Annex D. The sheets shall then be

examined for any visible cracks, delamination or other defects in the sheets, which shall not be of a degree as to affect their performance in use.

#### 5.4.3.3 Apparent density

The manufacturer shall indicate the nominal value of the apparent density of the sheets.

When measured in accordance with Annex D, the sheets shall have an apparent density equal to this value with a tolerance of  $\pm 10$  percent.

#### 5.4.3.4 Warm water

When tested in accordance with Annex D, any visible cracks, delamination or other defects in the sheets shall not be of a degree as to affect their performance in use.

The specimens shall exhibit a ratio  $L$  as defined in D-4.4 not less than 0.70. This is equivalent to a decrease in load of not more than 15 percent when the coefficient of variation is 15 percent.

#### 5.4.3.5 Heat-Rain

When tested in accordance with Annex D. Any visible cracks, delamination or other defects in the sheets shall not be of a degree as to affect their performance in use.

### 5.5 Tests

#### 5.5.1 Acceptance Tests

The following acceptance tests shall be carried out at the manufacturer's works on sheets as-delivered, the maturity of which is guaranteed by the manufacturer. Sampling levels and acceptance criteria shall be as defined in 8.

##### 5.5.1.1 Compulsory tests

- a) Dimensions (Annex B), and
- b) Mechanical characteristics : breaking load (Annex C).

##### 5.5.1.2 Optional tests (at purchaser's request)

Apparent density (Annex D).

#### 5.5.2 Type Tests

These type tests should be repeated every five years and/or whenever required in accordance with 3.2. These tests shall be:

- a) Mechanical characteristics : deflection (Annex C),
- b) Impermeability (Annex D),
- c) Frost resistance (Annex D),
- d) Warm water (Annex D), and
- e) Heat-Rain (Annex D).

Frost resistance, warm water and heat-rain tests are optional tests as per the requirements of the purchaser.

## 6 FITTINGS

### 6.1 Composition

The fittings shall be of composition similar to the sheets.

### 6.2 General Appearance and Finish

Fittings are components with particular shapes which are fitted to profiled sheets and complete the roofing at the verge, ridge and eaves or perform functions such as ventilation, daylight-admission, etc.

Fittings shall have straight and clean edges. They may have lapping joints. They may be left in their natural colour or colouring matter may be added in the composition. They may also receive adherent coloured or uncoloured coatings on their surface.

### 6.3 Characteristics

#### 6.3.1 Dimensions

The fittings shall have dimensions and tolerances appropriate for use with their corresponding sheets.

#### 6.3.2 Physical Characteristics

##### 6.3.2.1 Frost resistance (type characteristics)

This test shall be carried out for the fittings to be used with sheets meant for frost resistant applications.

When tested as specified in 6.3.2.2 (optional test), any visible cracks, delamination or other defects in the fittings should not be of a degree as to affect their performance in use.

These characteristics shall be determined on products as-delivered wherever practical. The results are identified as applying to coated or uncoated materials.

Failure of the coating does not constitute failure of the product.

##### 6.3.2.2 Frost resistance test

The specimens shall be cut from complete fittings and shall be approximately 200 mm by 200 mm. The apparatus shall be the same as for the sheets.

Submit five specimens cut from different fittings to the same freeze/thaw cycle as for the sheets. After the cycles are completed, examine them with the naked eye for cracks, delamination or other defects and record any observations. The result complies with this standard if the observations are in accordance with the requirements given in 6.3.2.1.

## 7 MARKING

7.1 Each sheet/ fitting shall be indelibly stamped or marked by any suitable method, with the following information:

- a) Identification of the source of the manufacturer;
- b) Date of manufacture;
- c) Type, Category and Class of sheet;
- d) Size and thickness of sheet; and
- e) The words 'FROST RESISTANT' on the sheets/fittings suitable for frost resistant applications.

## 7.2 BIS Certification Marking

Each sheet/fitting may also be marked with the Standard Mark.

**7.2.1** The use of Standard Mark is governed by the provisions of the *Bureau of Indian Standards Act, 1986* and the Rules and Regulations made thereunder. The details of conditions under which a licence for the use of Standard Mark may be granted to manufacturers or producers may be obtained from the Bureau of Indian Standards.

## 8 SAMPLING AND ACCEPTANCE CRITERIA

### 8.1 Scale of Sampling

#### 8.1.1 Lot

In any consignment all the sheets of same size, type, category and class and of the same thickness and manufactured under similar conditions of production shall be grouped together to constitute a lot.

**8.1.2** The number of sheets to be selected at random from the lot shall be in accordance with Table 2.

### 8.2 Inspection by Variables

The inspection shall be carried out, on one sample, the size of which is given in col (2) of Table 2, in accordance with 8.2.1 to 8.2.7.

**8.2.1** Divide the readings in the order in which they have been recorded into groups of 5, except when the sample size is 7, in which case the group size is the same as the sample size.

**8.2.2** For each group, compute the range  $R$ .

**8.2.3** From the group ranges  $R$  compute the average range  $\bar{R}$ .

**8.2.4** Compute the sample mean  $\bar{X}$  by dividing the sum of the measurements by the sample size.

**8.2.5** Obtain from col (3) of Table 2 the coefficient  $k$ .

**8.2.6** Compute the acceptability limit  $AL$  and determine the acceptability of the lot by means of Table 3.

**8.2.7** The conformity of the lot to the requirement of this standard shall be obtained on the basis of the tests on the sheets selected from it.

**Table 2 Sample Size and Acceptance Coefficient**  
(Clauses 8.1.2, 8.2 and 8.2.5)

Size of the Lot (1)	Sample Size (2)	Acceptance Coefficient (3)
≤ 150	3	0.502
151 to 180	3	0.502
181 to 500	4	0.450
501 to 1 200	5	0.431
1 201 to 3 200	7	0.405
3 201 to 10 000	10	0.507

**Table 3 Acceptance Criteria for Inspection by Variables**  
(Clause 8.2.6)

Limit Prescribed in Relevant Standard	$AL$	Acceptance, If	Rejection, If
Lower specified limit, $L_l$	$L_l + k\bar{R}$	$\bar{x} \geq L$	$\bar{x} < AL$
Upper specified limit, $L_u$	$L_u + k\bar{R}$	$\bar{x} \leq AL$	$\bar{x} > AL$

## 9 INSPECTION AND MANUFACTURERS TEST CERTIFICATE

**9.1** The purchaser or his representative shall have access at all reasonable times to the manufacturer's stock area for the purpose of inspecting the materials and products and selecting and testing the sheets, which shall be so conducted as not to interfere unnecessarily with the loading in the carriers.

**9.2** The manufacturer shall, upon request, furnish the purchaser or his representative with the certificate that the finished product comply with the standard in all respects.

## 10 SAFETY RULES

- a) *Product Identification* — Sheets shall be marked with indelible characters to show that they do not contain asbestos.
- b) *Information to Users* — The manufacturer should, through its distribution system, supply adequate information to the users concerning safety precautions to be taken during handling or machining of products, like excessive exposure to dust by cutting, drilling, sanding and turning or similar operations should be avoided by one or several of the following means:
  - 1) using low speed power tools,
  - 2) wetting the product,
  - 3) using personal protective equipment, (respirators), and
  - 4) use of hand-tools.



## ANNEX A

(Clause 2)

## LIST OF REFERRED INDIAN STANDARDS

IS No.	Title	IS No.	Title
269 : 1989	Specification for ordinary Portland cement, 33 grade ( <i>fourth revision</i> )	1489 (Part 2) : 1991	Specification for Portland pozzolana cement: Part 2 Calcined clay based ( <i>third revision</i> )
455 : 1989	Specification for Portland slag cement ( <i>fourth revision</i> )	3812 : 1981	Specification for fly ash for use as pozzolana and admixture ( <i>first revision</i> )
459 : 1992	Specification for corrugated and semi-corrugated asbestos cement sheets ( <i>third revision</i> )	8041 : 1990	Specification for rapid hardening Portland cement ( <i>second revision</i> )
1489 (Part 1) : 1991	Specification for Portland pozzolana cement: Part 1 Fly ash based ( <i>third revision</i> )	8112 : 1989	Specification for 43 grade ordinary Portland cement ( <i>first revision</i> )
		12269 : 1987	Specification for 53 grade ordinary Portland cement

## ANNEX B

(Clauses 5.4.1, 5.4.1.2 and 5.5.1.1)

## METHOD FOR TESTING PROFILE AND OTHER DIMENSIONS

**B-1 CHECKING PROFILE****B-1.1 Preparation of Specimen**

The specimen shall be a complete sheet as-delivered without conditioning.

**B-1.2 Apparatus**

**B-1.2.1 Smooth Flat Surface**—with dimensions appropriate to the dimensions of the sheets.

**B-1.2.2 Ruler**—graduated in mm.

**B-1.2.3 Micrometer**—with hemispherical head accurate to 0.1 mm.

**B-1.3 Procedure**

Lay the sheet flat and square on the flat surface in accordance with Fig. 3, ensuring that the valley of every corrugations is in contact with it.

**B-1.3.1 Measurement of Distance Between Extreme Complete Corrugation Pitch, *a***

The total length over extreme complete corrugation pitch shall be measured (*see* Fig. 4).

Any other measurement methods with an accuracy equal or higher may be used.

**B-1.3.2 Measurement of Corrugation Height, *h***

Choose three complete corrugations on a sheet. On each of them, with the micrometer, take three measurements to the nearest 0.1 mm regularly spaced down the length of the sheet in accordance with Fig. 5.

Any other measurement method with an accuracy equal or higher may be used.

**B-1.4 Expression and Interpretation of Results****B-1.4.1 Pitch**

The total length measured over extreme corrugation shall not vary from the tolerance given in 5.4.1.4 (a).

**B-1.4.2 Corrugation Height**

Each result is the arithmetical average of the three measurements on each corrugation, expressed in mm, to the nearest 1 mm and shall be within the tolerance given in 5.4.1.4 (b).

**B-2 MEASUREMENT OF LENGTH AND WIDTH****B-2.1 Preparation of Specimen**

The specimen shall be a complete sheet as-delivered without conditioning.

**B-2.2 Apparatus**

**B-2.2.1 Smooth Flat Surface**—with dimensions appropriate to the dimensions of the sheet.

**B-2.2.2 Ruler**— graduated in mm.

**B-2.2.3 Two Rectangular Caliper Blocks**

**B-2.3 Procedure**

Lay the sheet flat on the surface in accordance with Fig. 3, ensuring that the valley of every corrugation is in contact with it.

To measure the length, take three measurements, one in the middle and at two points approximately 50 mm from each side or further to avoid mitered corners (see Fig. 3).

To measure the overall width, take three measurements, one in the middle and at two points approximately 50 mm from each side or further to avoid mitered corners (see Fig. 3).

To measure the effective width, take two sheets and place one over the other, such that the down lap of one sheet is in lap with the uplap of the other sheet. Take two measurements at both the edges, as shown in Fig. 4.

**B-2.4 Expression and Interpretation of Results**

Read each measurement to the nearest 1 mm, calculate the arithmetic average of the length, width and compare them with the requirements given in 5.4.1.4 (c) and 5.4.1.4 (d) respectively.

The results are considered satisfactory if they conform to the requirements.

**B-3 THICKNESS CHECK**

**B-3.1 Preparation of Specimen**

The specimen shall be a complete sheet as-delivered without conditioning.

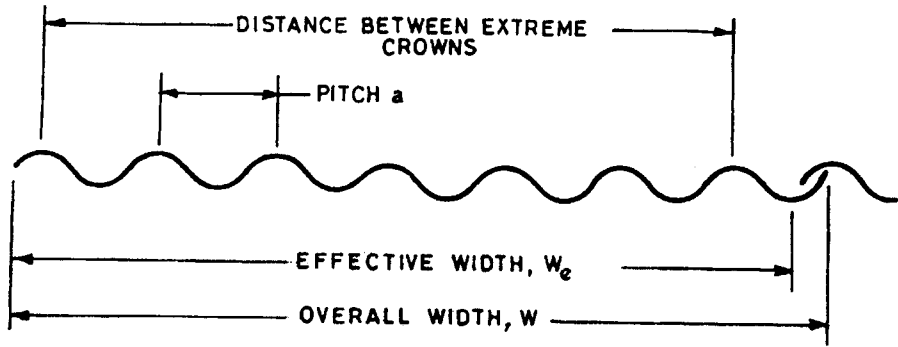

FIG. 4 ARRANGEMENT FOR MEASUREMENT OF DISTANCE BETWEEN EXTREME COMPLETE CORRUGATION PITCH, ETC

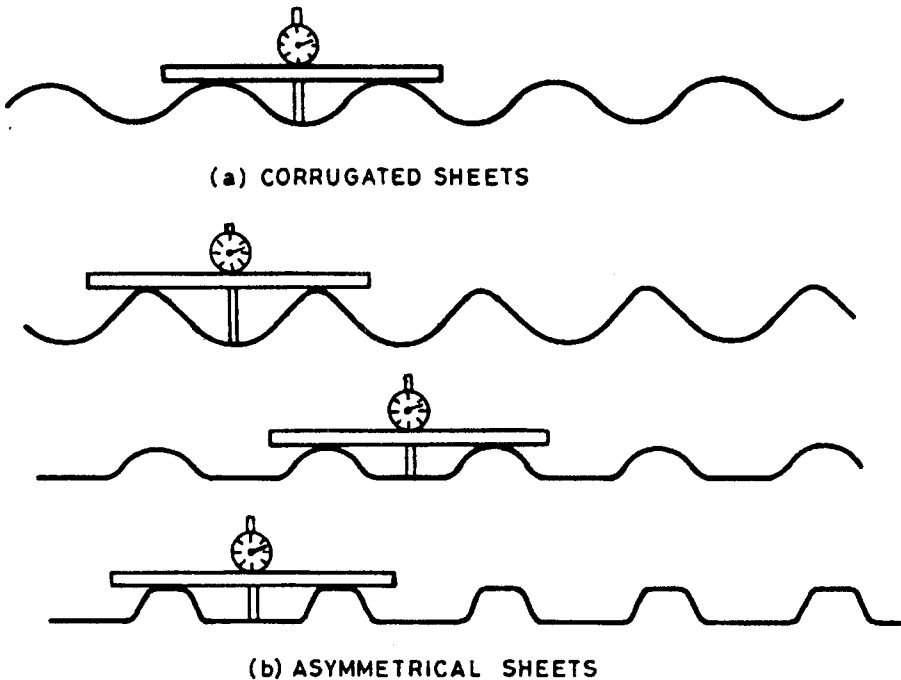
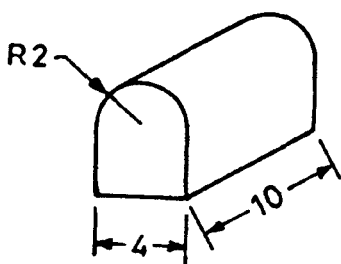

FIG. 5 ARRANGEMENT FOR MEASUREMENT OF CORRUGATION HEIGHT OF SHEETS

### B-3.2 Apparatus

**B-3.2.1** Micrometer with hemicylindrical plates as in Fig. 6, accurate to 0.05 mm.



All dimensions in millimetres.

FIG. 6

### B-3.3 Procedure

Make the measurements approximately 15 mm from the end,

- in the valley and at the crown of the corrugation for sheets of Type A, and
- on the crown and on the flank of the corrugations for sheets of Type B.

Measure the thickness at 6 points (3 crowns and 3 valleys for Type A, 3 crowns and 3 flanks for Type B).

### B-3.4 Expression and Interpretation of Results

The results are the individual measurements and the average of all measurements, expressed in mm, which shall be compared with the requirement given in 5.4.1.2 and 5.4.1.4(e).

The results are considered to be satisfactory if they conform to the requirements.

## B-4 SQUARENESS CHECK

### B-4.1 Preparation of Specimen

The specimen shall be a complete sheet as delivered without conditioning.

### B-4.2 Apparatus

**B-4.2.1** A smooth flat surface with dimensions appropriate to the dimensions of the sheet.

**B-4.2.2** A rectangular frame with two corrugated ends and two straight sides or any other appropriate device to check the squareness of ends with respect to corrugations with an accuracy of 1 mm.

**B-4.2.3** A graduated metal ruler reading to 0.5 mm.

### B-4.3 Procedure

Lay the sheet on the flat surface ensuring that the valley of every corrugation is in contact with it.

Measure the out of squareness at each end, as indicated in Fig. 7 as an example.

### B-4.4 Expression and Interpretation of Results

The results in mm shall be compared with the requirements given in 5.4.1.4(f). The results are considered to be satisfactory, if they conform to the requirement.

## B-5 HEIGHT OF EDGES

### B-5.1 Preparation of Specimen

The specimen shall be a complete sheet as delivered without conditioning.

### B-5.2 Apparatus

**B-5.2.1** A smooth flat surface with dimension appropriate to the dimension of the sheet.

**B-5.2.2** Two appropriate measurement devices, one device for the ascending corrugation ( $h_{om}$ ) and one device for the descending corrugation ( $h_{od}$ ).

### B-5.3 Procedure

Lay the sheet flat on the surface ensuring that the valley of the every corrugation is in contact with it. Measure the height of both edges as in Fig. 8 with the device with an accuracy of 1mm.

### B-5.4 Expression and Interpretation of Results

The results at any point on the edges of the sheets, expressed in mm, shall be compared with the requirements given in 5.4.1.4 (g).

The results are considered to be satisfactory, if they conform with the requirements.

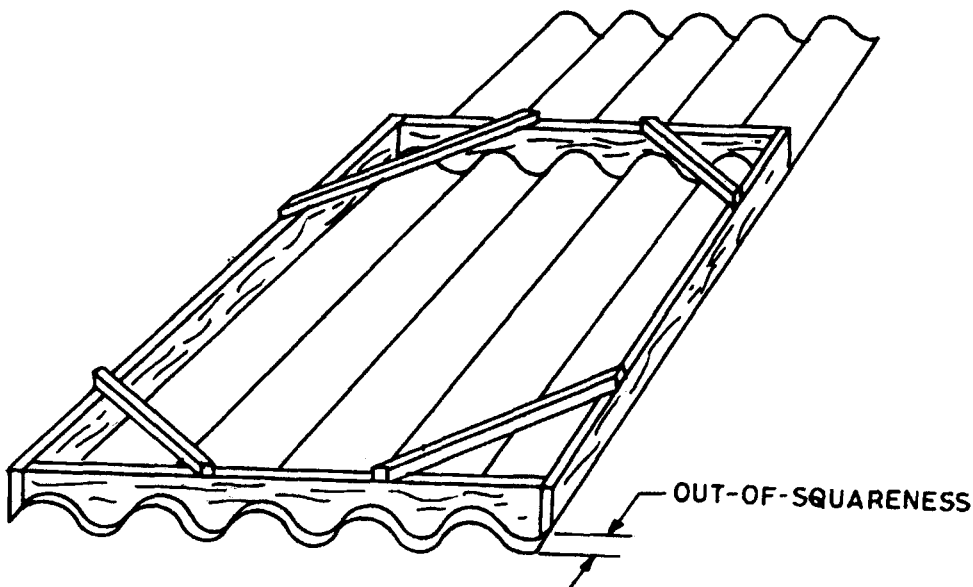

FIG. 7 ARRANGEMENT FOR CHECKING OUT-OF-SQUARENESS

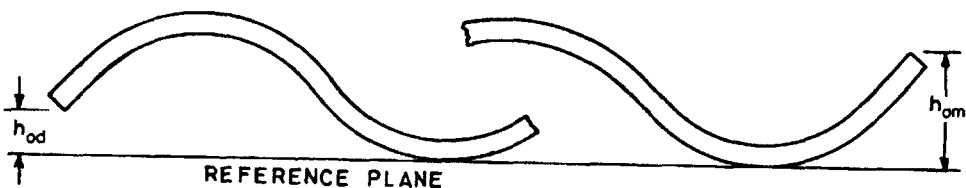

FIG. 8 ARRANGEMENT FOR MEASURING HEIGHT OF EDGES

## ANNEX C

(Clauses 5.4.2.1, 5.4.2.2, 5.5.1.1, D-4.2.2 and D-4.3)

### METHOD FOR BREAKING LOAD TEST

#### C-1 BREAKING LOAD TEST

##### C-1.1 Preparation of Specimen

The test specimen shall be a complete sheet, or a transversally cut sheet with a minimum length of 1.2 m. The manufacturer shall guarantee its maturity.

##### C-1.2 Apparatus

**C-1.2.1 Bending Test Machine**—with a constant rate of deflection when applying the load and with an error of exactitude and an error of reproducibility less than or equal to 3 percent. Where this facility is not available, a constant rate of loading is acceptable.

This machine comprises:

- a) Two parallel supports (one fixed) in the same horizontal plane and longer than the sample width. The upper surface of each support shall be flat and 50 mm in width. The distance between the supports shall be a clear span of 1.1 m.

For sheets with a corrugation height greater than 80 mm, the span shall be increased to at least 15 times the height of the corrugations

and breaking load adjusted by the ratio of this span to a span of 1.1 m for comparison with the requirements of Table 1.

For sheets shorter than 1.2 m, the span shall be reduced without going below 15 times the height of the corrugations or 700 mm, and the breaking load adjusted by the ratio of this span to a span of 1.1 m for comparison with the requirements of Table 1.

- b) A flat loading beam 230 mm wide located parallel to and equidistant from the supports, attached to the mechanism by means of a flexible joint.
- c) Three strips of felt or soft material approximately 10 mm thick, with length and width equal to the supports and loading beam.

**NOTE** — In case lower span other than recommended is used for testing (however, the span should not be less than 15 times the height of corrugation) the breaking load obtained thus shall be adjusted to the ratio of this span to a span of 1.1 m for comparison with the requirements of Table 4.

Before testing, immerse the specimen in water at an ambient temperature. Testing shall be carried out after wet conditioning. Condition specimens in accordance with Table 4.

**Table 4 Conditioning**  
(Clauses C-1.2.1 and C-1.3)

Test (1)	Conditioning Procedure (2)
Acceptance test	24 h immersion in water
Type test	Prior to bending test 7 days at ambient laboratory conditions followed by 24 h immersion in water

The specimen is placed on the supports (the smooth face in compression) at right angles with the corrugations and loaded at midspan by the flat beam evenly distributing the load applied to its centre, after interposition of the strips of felt or soft material.

The breaking load (*see* 3.6) or sag with maximum load shall occur between 10 s and 45 s after the beginning of loading.

Measure the deflection at midspan under 20 percent and 70 percent of the load which specifies the class.

#### C-4 EXPRESSION AND INTERPRETATION OF RESULTS

The breaking load per meter width, expressed in N/m, is given by the formula :

$$P_c = \frac{P}{W}$$

When a span  $l$  other than 1.1 m is used, the breaking load,  $P_c$  per metre width for comparison with Table 1 is given as

$$P_c = \frac{P}{W} \times \frac{l}{1.1}$$

The deflection at 20 percent and 70 percent of the load which specifies the category shall be expressed in mm and their difference calculated. Breaking load shall be compared to the requirements given in 5.4.2.1 and Table 1 and the deflection can be compared with 5.4.2.2. The results are considered to be satisfactory if they conform to the requirements.

## ANNEX D

(Clauses 5.4.3.1, 5.4.3.2, 5.4.3.3, 5.4.3.4, 5.4.3.5 and 5.5.1.2)

### METHOD FOR TESTING IMPERMEABILITY, FROST RESISTANCE, APPARENT DENSITY, IN WARM WATER AND AGAINST HEAT-RAIN

#### D-1 IMPERMEABILITY

##### D-1.1 Preparation of Specimen

The test shall be made on three whole sheets as-delivered or cut sheets with a minimum length of 1.2 m. The sheets shall be kept for 7 days in a laboratory atmosphere at an ambient condition.

##### D-1.2 Apparatus

###### D-1.2.1 Frame

The width of frame depends on the profile of the sheets and wherever possible more than 500 mm; the dimensions are shown in Fig. 9.

##### D-1.3 Procedure

Seal the frame on the sheet. Then fill the frame with water until the level is approximately 20 mm above the top of the corrugations. Examine the underface after 24 h.

##### D-1.4 Expression and Interpretation of Results

The result shall be assessed visually by comparison with the requirements given in of 5.4.3.1.

#### D-2 FROST RESISTANCE

##### D-2.1 Preparation of Specimens

The test shall be performed on five specimens cut one from each of five sheets. These specimens shall have the following dimensions:

- 300 mm in the direction of the corrugations, and
- 200 mm perpendicular to the corrugations.

##### D-2.2 Apparatus

**D-2.2.1 Freezer**—having a forced air circulation and capable of being regulated to the prescribed freezing conditions with a full load of test specimens.

**D-2.2.2 Thawing Equipment**—conforming to the prescribed thawing conditions.

**D-2.2.3 Water bath**—filled with water at ambient temperature.

##### D-2.3 Procedure

Immerse the specimens in water at an ambient temperature for 24 h intervals until the difference between two consecutive weighings is less than 0.5 percent.

Then subject the specimens to freeze/thaw cycles consisting of:

-

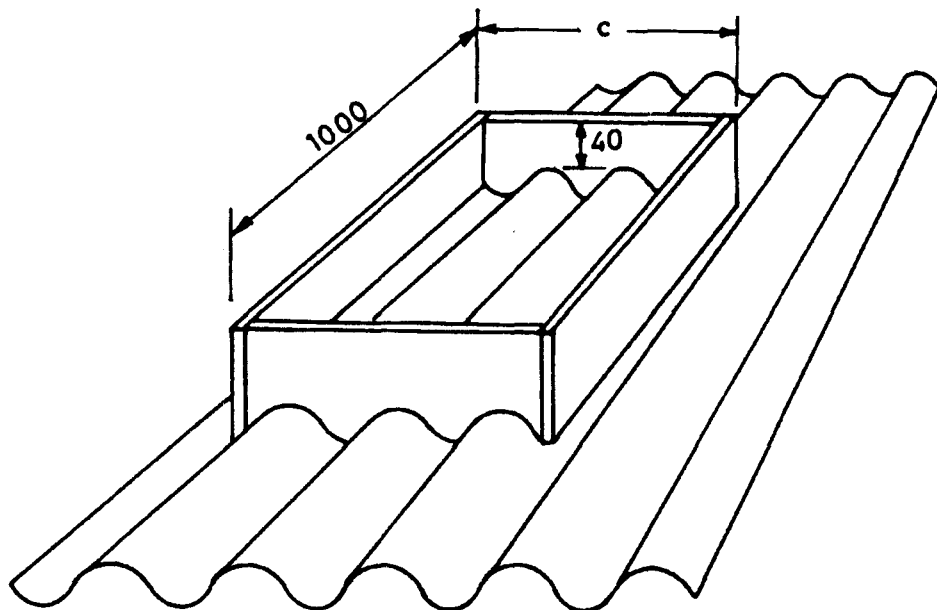

All dimensions in millimetres.

Category	C
Shallow corrugations	6 corrugations
Medium corrugations	4 corrugations
Deep corrugations	3 corrugations
Vary deep corrugations	2 corrugations

FIG. 9 ARRANGEMENT FOR TESTING IMPERMEABILITY

Then subject the specimens to freeze/thaw cycles consisting of:

- cooling in air to reach  $-20^{\circ}\text{C} \pm 2^{\circ}\text{C}$  within 1 h to 2 h, and holding at this temperature for 1h.
- thawing in water at ambient temperature within 1h to 2h, and holding in this condition for 1h. Then recommence freezing.

During both freezing and thawing, the specimens shall be positioned to enable free circulation of the conducting medium (air or water) around each. Freeze/thaw cycles may be controlled automatically or manually. Continuous automatic cycling is preferred. Manual supervision of freeze/thaw cycles shall record the completion of each cycle. Each freeze/thaw cycle shall take between 4 h and 6 h in total. An interval between cycles (72 h maximum) is permissible. During this interval specimens shall be stored at ambient condition.

NOTE—The temperature specified above refers to the freezing cavity.

The total number of freeze/thaw cycles shall be 50.

#### D-2.4 Expression and Interpretation of Results

The result shall be assessed visually by comparison with the requirements given in 5.4.3.2. The result is considered to be satisfactory if it conforms to the requirements.

### D-3 APPARENT DENSITY

#### D-3.1 Preparation of Specimen

A test specimen of size of approximately 40 mm  $\times$  60 mm shall be cut from the uncoated sheet.

#### D-3.2 Apparatus

**D-3.2.1 Ventilated Oven** — capable of achieving a temperature of  $100^{\circ}\text{C}$  to  $105^{\circ}\text{C}$  with full load of specimens.

**D-3.2.2 Weighing Scale** — accurate to within  $\pm 0.1$  percent and equipped to determine the immersed and non-immersed masses of the specimens.

#### D-3.3 Procedure

Determine the volume,  $V$  by immersion in water or another method having an accuracy equal or higher. In case of immersion, the test specimens shall be saturated in water beforehand.

Determine the mass,  $m$ , of the specimen after drying it in the ventilated oven maintained at  $100^{\circ}\text{C}$  to  $105^{\circ}\text{C}$  for  $24 \pm 1$ h.

#### D-3.4 Expression and Interpretation of Results

The apparent density is given by the formula :

$$\rho = \frac{m}{V}$$

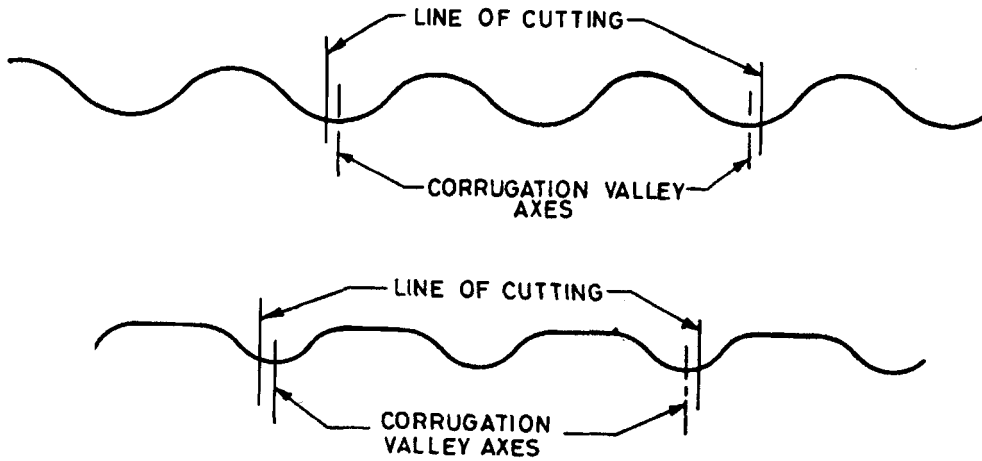

FIG. 10 ARRANGEMENT FOR WARM WATER TEST

It shall be compared with the requirements given in 5.4.3.3.

The result is considered to be satisfactory if it conforms to the requirements.

#### D-4 WARM WATER

This test investigates the possible degradation of the products by keeping them in warm water for a protracted period.

##### D-4.1 Preparation of Specimens

Cut 20 specimens longitudinally from the middle of a complete sheet, with two complete corrugations if the sheet is not wide enough on a complete corrugation. Longitudinal cutting shall be done in the axis of the valley as indicated in Fig. 10, allowing a little beyond this axis. Specimens may be transversally cut to a length allowing a free span of 15 times the height of corrugations.

##### D-4.2 Apparatus

**D-4.2.1 Water Bath** — capable of temperature control to  $60\text{ }^{\circ}\text{C} \pm 2\text{ }^{\circ}\text{C}$ .

**D-4.2.2 Bending Test Machine** — as specified in Annex C.

##### D-4.3 Procedure

Divide the specimens at random into two lots of 10. Submit one lot of 10 specimens to the breaking load test according to Annex C and, at the same time, immerse the second lot of 10 specimens in water at  $60\text{ }^{\circ}\text{C} \pm 2\text{ }^{\circ}\text{C}$  for  $56\text{ days} \pm 2\text{ days}$ . The pieces of products used for saturation shall be broken down to a size and be of sufficient quantity to ensure that saturation is complete.

At the end of this period, place the second lot of specimens in a laboratory atmosphere for 7 days. Examine the specimens with the naked eye in order to detect any cracks or obvious defects such as might affect their performance in use and record any observations. Then carry out the breaking load test as specified in Annex C including preliminary conditioning as given in Annex C.

##### D-4.4 Expression and Interpretation of Results

For each of the two lots, calculate the mean breaking load taking for  $W$  the average of two measurements of the width of the specimens and the standard deviation of the values obtained.

Let  $M_1$  and  $s_1$  be the mean and the standard deviation of the results obtained on the first lot, and  $M_2$  and  $s_2$  be the mean and the standard deviation of the results obtained on the second lot tested after immersion in water.

Calculate the lower estimation of the mean breaking load after immersion in warm water at 95 percent confidence level as:

$$L_s = M_2 - 0.58 s_2$$

and the upper estimation of the mean breaking load at 95 percent confidence level of the reference lot as:

$$L_i = M_1 + 0.58 s_1$$

Calculate the 95 percent lower confidence limit as follows :

$$L = \frac{L_i}{L_s}$$

The visual observations and the results  $L$  shall be compared with the requirements of 5.4.3.4. The results are considered to be satisfactory if they conform to the requirements.

**D-5 HEAT-RAIN****D-5.1 Preparation of Specimens**

The test shall be carried out on 9 full size sheets.

**D-5.2 Apparatus****D-5.2.1 Suitable Frame**

Inclined at  $25 \pm 5^\circ$ , placed in a space without draught but conveniently ventilated.

**D-5.2.2** A heating device calibrated in order to maintain a blackbody<sup>1)</sup> surface temperature of  $70 \pm 5^\circ\text{C}$  on the surface at the crown of corrugations. It should provide an approximately uniform power output during the whole heating period.

**D-5.2.3** A water sprinkling device with an output of approximately 2.5 l/min per square metre of plate surface, delivering water at an ambient temperature.

**D-5.3 Procedure**

Submit the test specimens to preliminary conditioning by storage to equilibrium for 7 days in a laboratory atmosphere with suitable aeration, with the specimens fixed on the frame according to the manufacturer's laying instructions. Lay each sheet with actual or

simulated overlaps at the four edges. Submit the sheets to 25 cycles as described in Table 5.

After 25 cycles, inspect the sheets for cracking (longitudinal, transverse and at the fixing points), delamination, or other visual defects.

**D-5.4 Expression and Interpretation of Results**

The result of the visual assessment shall conform to requirements given in 5.4.3.5.

The result is considered to be satisfactory if it conforms to the requirements.

**Table 5 Heat-Rain Cycle**  
(Clause D-5.3)

Operation (1)	Duration (2)
Wetting ( $2.5 \text{ l/min/m}^2$ )	2 h 50 min
Interval	10 min
Heating $70 \pm 5^\circ\text{C}$	2 h 50 min
Interval	10 min
Total	6 h

<sup>1)</sup>For this test an aluminium plate of 1mm thickness painted with a matt black paint is used as a blackbody. The measurement device is a thermocouple or a similar device fixed behind the aluminium plate.



**ANNEX E**  
*(Foreword)*  
**COMMITTEE COMPOSITION**

Cement Matrix Products Sectional Committee, CED 53

<i>Chairman</i>	<i>Representing</i>
SHRI S. A. REDDI	Gammon India Ltd, Mumbai
<i>Members</i>	
SHRI P. S. KALANI	All India Small Scale AC Pressure Pipe Manufacturers' Association, Secunderabad
SHRI N. KISHAN REDDY ( <i>Alternate</i> )	B.G. Shirke Construction Technology Ltd, Pune
SHRI G. R. BHARITKAR	Central Building Research Institute, Roorkee
COL D. V. PADSALGIKAR ( <i>Alternate</i> )	Central Public Works Department, New Delhi
DR B. K. RAO	Directorate General of Supplies & Disposals, New Delhi
DR S. K. AGARWAL ( <i>Alternate</i> )	Engineer-in-Chief's Branch, Army Headquarters, New Delhi
SHRI P. SUBRAMANIAN	Eternit Everest Ltd, New Delhi
SHRI K. P. ABRAHAM ( <i>Alternate</i> )	Federation of UP Pipe Manufacturers, Lucknow
SHRI S. M. MUNJAL	Hindustan Prefab Ltd, New Delhi
SHRI R. K. AGARWAL ( <i>Alternate</i> )	Housing and Urban Development Corporation, New Delhi
SHRI MAHENDRA PRASAD	Hyderabad Industries Ltd, Hyderabad
SHRI A. K. AGGARWAL ( <i>Alternate</i> )	Municipal Corporation of Delhi, Delhi
SHRI K. SRIVASTAVA	Municipal Corporation of Greater Mumbai, Mumbai
SHRI S. P. RASTOGI	National Council for Cement and Building Materials, Ballabgarh
SHRI A. K. CHADHA	National Test House, Calcutta
SHRI J. R. SIL ( <i>Alternate</i> )	Research, Designs and Standards Organization (Ministry of Railways) Lucknow
SHRI V. SURESH	Rural Electrification Corporation Ltd, New Delhi
SHRI S. K. TANEJA ( <i>Alternate</i> )	Structural Engineering Research Centre (CSIR), Chennai
SHRI K. H. GANGWAL	Small Scale Industries Services Institute, Ministry of Commerce and Industry, New Delhi
SHRI V. PATTABHI ( <i>Alternate</i> )	Spun Pipes Manufacturer's Association of Maharashtra, Pune
SHRI O. P. AGARWAL	Tamil Nadu Water Supply & Drainage Board, Chennai
SHRI J. L. DHINGRA ( <i>Alternate</i> )	The Associated Cement Companies Ltd, Thane
CHIEF ENGINEER (CEMENT CONCRETE ROAD)	The Indian Hume Pipe Co Ltd, Mumbai
DEPUTY CHIEF ENGINEER (PURCHASE) ( <i>Alternate</i> )	Director General, BIS ( <i>Ex-officio Member</i> )
DR C. RAJKUMAR	
SHRI H. K. JULKA ( <i>Alternate</i> )	
SHRI D. K. KANUNGO	
SHRI T. CHOUDHURY ( <i>Alternate</i> )	
JOINT DIRECTOR STANDARDS (B&S)	
ASSTT DESIGN ENGINEER ( <i>Alternate</i> )	
SHRI M. A. AZEEZ	
SHRI P. D. GAIKWAD ( <i>Alternate</i> )	
SHRI N. P. RAJAMANE	
DR M. NEELAMEGAM ( <i>Alternate</i> )	
SHRI C. H. SUBRAMANIAN	
SHRI A. DUTTA ( <i>Alternate</i> )	
SHRI C. Y. GAVHANE	
SHRI D. N. JOSHI ( <i>Alternate</i> )	
SHRI S. HARIRAMASAMY	
SHRI B. V. B. PAI	
SHRI M. S. DANDWATE ( <i>Alternate</i> )	
SHRI P. D. KELKAR	
SHRI P. R. C. NAIR ( <i>Alternate</i> )	
SHRI S. S. SETHI,	
Director (Civ Engg)	

*Member-Secretary*  
SHRI SANJAY PANT  
Deputy Director (Civ Engg), BIS

(Continued from page 15)

Fibre Reinforced Cement Products Subcommittee, CED 53:1

*Convener*

DR C. RAJKUMAR

*Members*

SHRI P.S. KALANI

SHRI N. KISHAN REDDY (*Alternate*)

DR B. K. RAO

DR S. K. AGARWAL (*Alternate*)

SHRI S. B. SURI

SHRI N. CHANDRASEKARAN (*Alternate*)

SUPERINTENDING ENGINEER (TADC)

ENGINEER-IN CHIEF (WATER)

SHRI N. S. BASU

SHRI T. N. OBOVEJA (*Alternate*)

SHRI N. G. BASAK

SHRI P. K. JAIN (*Alternate*)

COL V. K. P. SINGH

MAJ R. S. PHANWALA (*Alternate*)

DR N. BALASUBRAMANIAN

SHRI K. K. MALIK (*Alternate*)

SHRI J. S. SANGANERIA

SHRI V. K. KASLIWAL (*Alternate*)

SHRI A. K. CHATURVEDI

SHRI S. M. LALWANI (*Alternate*)

SHRI V. PATTABHI

SHRI A. K. GUPTA (*Alternate*)

SHRI P. L. JAIN

SHRI M. M. JAIN (*Alternate*)

DR P. S. KALANI

SHRI T. S. SUMMI (*Alternate*)

SHRI RAJ KUMAR

SHRI S. C. KUMAR (*Alternate*)

DR N. K. JAIN

SHRI S. K. BANERJEE

SHRI S. GANPATHY

DEPUTY DIRECTOR STANDARDS (B&F)

ASSTT DESIGN ENGINEER (B&F) (*Alternate*)

SHRI K. P. GOENKA

SHRI I. P. GOENKA (*Alternate*)

*Representing*

National Council for Cement and Building Materials, Ballabgarh

All India Small Scale AC Pressure Pipe Manufacturers' Association,  
Secunderabad

Central Building Research Institute, Roorkee

Central Soil and Materials Research Station, New Delhi

Central Public Works Department, New Delhi

Delhi Water Supply & Sewage Disposal Undertaking, New Delhi  
Directorate General of Supplies and Disposals, New Delhi

Director General of Technical Development, New Delhi

Engineer-in-Chief's Branch, Army Headquarters, New Delhi

Eternit Everest Ltd, New Delhi

Geological Survey of India, Calcutta

Gujarat Composite Ltd, Ahmedabad

Hyderabad Industries Ltd, Hyderabad

Jain Trading Corporation, Kota

Kalani Asbestos Cement Private Ltd, Indore

Ministry of Industry (SSI), New Delhi

National Council for Cement and Building Materials, Ballabgarh

National Test House, Calcutta

Ramco Industries Ltd, Chennai

Research, Designs & Standards Organization (Ministry of Railways),  
Lucknow

Sarbamangala Industries, Calcutta

## Bureau of Indian Standards

BIS is a statutory institution established under the *Bureau of Indian Standards Act, 1986* to promote harmonious development of the activities of standardization, marking and quality certification of goods and attending to connected matters in the country.

### Copyright

BIS has the copyright of all its publications. No part of these publications may be reproduced in any form without the prior permission in writing of BIS. This does not preclude the free use, in the course of implementing the standard, of necessary details, such as symbols and sizes, type or grade designations. Enquiries relating to copyright be addressed to the Director (Publications), BIS.

### Review of Indian Standards

Amendments are issued to standards as the need arises on the basis of comments. Standards are also reviewed periodically; a standard along with amendments is reaffirmed when such review indicates that no changes are needed; if the review indicates that changes are needed, it is taken up for revision. Users of Indian Standards should ascertain that they are in possession of the latest amendments or edition by referring to the latest issue of 'BIS Catalogue' and 'Standards: Monthly Additions'.

This Indian Standard has been developed from Doc : No. CED 53 ( 5784 ).

### Amendments Issued Since Publication

Amend No.	Date of Issue	Text Affected

### BUREAU OF INDIAN STANDARDS

#### Headquarters :

Manak Bhavan, 9 Bahadur Shah Zafar Marg, New Delhi 110 002  
Telephones : 323 01 31, 323 33 75, 323 94 02

Telegrams : Manaksanstha  
(Common to all offices)

#### Regional Offices :

	Telephone
Central : Manak Bhavan, 9 Bahadur Shah Zafar Marg NEW DELHI 110 002	{ 323 76 17 323 38 41
Eastern : 1/14 C. I. T. Scheme VII M, V. I. P. Road, Kankurgachi CALCUTTA 700 054	{ 337 84 99, 337 85 61 337 86 26, 337 91 20
Northern : SCO 335-336, Sector 34-A, CHANDIGARH 160 022	{ 60 38 43 60 20 25
Southern : C. I. T. Campus, IV Cross Road, CHENNAI 600 113	{ 235 02 16, 235 04 42 235 15 19, 235 23 15
Western : Manakalaya, E9 MIDC, Marol, Andheri (East) MUMBAI 400 093	{ 832 92 95, 832 78 58 832 78 91, 832 78 92
Branches : AHMADABAD. BANGALORE. BHOPAL. BHUBANESHWAR. COIMBATORE. FARIDABAD. GHAZIABAD. GUWAHATI. HYDERABAD. JAIPUR. KANPUR. LUCKNOW. NAGPUR. PATNA. PUNE. RAJKOT. THIRUVANANTHAPURAM.	