

भारतीय मानक
कंक्रीट संरचना के लिए फाल्सवर्क — मार्गदर्शिका

Indian Standard
FALSEWORK FOR CONCRETE STRUCTURES —
GUIDELINES

ICS 91.220

© BIS 1999

BUREAU OF INDIAN STANDARDS
MANAK BHAVAN, 9 BAHADUR SHAH ZAFARMARG
NEW DELHI 110002

FOREWORD

This Indian Standard was adopted by the Bureau of Indian Standards, after the draft finalized by the Cement and Concrete Sectional Committee had been approved by the Civil Engineering Division Council.

Falsework, in the widest meaning is the total system of support for freshly placed concrete including the mould or sheathing which contacts the concrete as well as supporting members, hardware and necessary bracing, etc.

Several failures of falsework have focussed attention on the need for guidelines in the design and construction of falsework so as to achieve safety, reliability and economy in concrete construction. The importance of falsework at times, is not appreciated well. The Sectional Committee decided to evolve Guidelines for falsework for concrete structures. The purpose of these guidelines, in general, is to promote good engineering practice, safety, economy, speed, and proper finish in concrete construction. The main emphasis in falsework practice should be on overall safety.

The responsibility for falsework be allocated, to cover the stages of concept, design, erection, inspection and release, such that no vital stage is missed which otherwise can lead to catastrophic failure or expensive delays. The success of a scheme of falsework for concrete in a large project depends, as much upon good organization, planning, supervision and checks at critical stages, as upon good design and workmanship. Best design can be nullified by inadequate detailing or wrong sequence of construction or poor supervision.

In the preparation of these guidelines assistance has been derived from Formwork for Concrete — SP 4, American Concrete Institution; Code of Practice for Falsework, British Standards Institution; Recommendations of the Advisory Committee on Falsework, Prof S.L. Bragg, and Military Engineering, Vol XIV, Part I, Concrete Practice, HMSO.

While formulating the guidelines, it has been felt that one of the purposes of the code would be to develop awareness amongst engineers and builders about the falsework. At this stage it may not be necessary to deal here, with all situations and complications in design, erection and management of falsework. However, further elaboration are planned to be incorporated in subsequent editions, on the basis of experience gained in using these guidelines.

The composition of the technical committee, responsible for the formulation of this standard is given in Annex D.

Indian Standard

FALSEWORK FOR CONCRETE STRUCTURES — GUIDELINES

1 SCOPE

1.1 These guidelines cover the common requirements of materials, design and construction of falsework, as applied to general building and ordinary civil engineering constructions excluding bridges and special structures. General building construction for the purpose of this code, means structures up to 4 storeys or 15 m height and dead load of formwork and concrete not exceeding 20 kN/m². The provisions of these guidelines can be applied to other buildings and structures with additional requirements.

1.2 The requirements of special falsework systems, such as moving forms, climbing forms, slipforms, flying forms, etc, are not covered in these guidelines. It also does not govern many requirements of moulds for precast and prestressed concrete components, architectural concrete and lost forms.

2 REFERENCES

The Indian Standards listed in Annex A contain provisions which through reference in this text, constitute provision of this standard. At the time of publication, the editions indicated were valid. All standards are subject to revision, and parties to agreements based on this standard are encouraged to investigate the possibility of applying the most recent editions of the standards listed in Annex A.

3 TERMINOLOGY

For the purpose of this code, the definitions given in IS 6461 (Part 5) shall apply.

4 REQUIREMENTS OF FALSEWORK

4.1 Safety and Integrity

The falsework shall be planned with safety of permanent constructions and workers. It shall be adequately braced laterally and diagonally.

4.2 Rigidity and Deflection

Falsework shall be rigid enough so that the deflections under the dead load and live loads and forces caused by ramming and vibration of concrete and other incidental loads imposed upon it during and after casting of concrete are well within permissible limits (see 7.5). The rigidity can be achieved by suitable number of ties and braces. Screw jacks or hard board wedges, where required shall be provided to control falsework settlement.

4.3 Strength and Stability

The falsework shall be of adequate strength and so detailed as to withstand all anticipated loads including lateral loads, vibrations and small accidental loads. The system shall be such as to prevent progressive failure due to minor causes.

4.4 Functional Requirements

4.4.1 *Erection and Release*

Falsework shall be so designed and constructed that they can be removed in parts in the desired sequence without damaging the surface of concrete or disturbing other sections or causing collapse of the formwork systems. The connections joining various components of the formwork should be capable of being easily removed while formwork stripping.

4.4.2 *Ease of Inspection*

The scheme of falsework should facilitate adequate and safe access to all areas for inspection.

4.4.3 *Shape and Size*

The falsework shall be erected such that the shape and dimensions of the concrete structures are conforming to the drawings, the specifications and tolerances. Chamfers, bevelled edges and mouldings if specified, should be provided in the forms.

4.4.4 *Finish*

The formwork should be hard enough so as to not to get damaged due to operations of reinforcement fixing, pouring and vibrating of concrete and removal of forms. The materials of formwork shall depend upon the final finished surface required.

4.4.5 *Reuse*

It shall be designed and planned to permit maximum reuses, reducing the cost of concrete work. While avoiding unsafe or poor practices, adequate planning shall be done right from initial stages to develop a viable reuse plan, utilising member sections and sizes that will involve minimum material cutting, wastage and minimum assembly.

5 TYPE OF FALSEWORK

5.1 Falsework may be fabricated at site, or partially or wholly prefabricated.

5.2 Commercially available falsework systems may be used, provided those meet the requirements of these guidelines and detailed information as necessary is furnished, unless otherwise it is specifically agreed between the supplier and agencies executing and supervising the construction.

When propriety systems of falsework are employed, it is recommended that the designer may obtain the information as per Annex B from the suppliers.

6 MATERIALS AND ACCESSORIES FOR FALSEWORK

6.1 General

The falsework may consist of timber, plywood, steel, aluminium, PVC, plastics, ferro-cement or any engineering material. General requirements and specific use of these materials are given in 6.1.1 to 6.1.4.

6.1.1 Timber

Timber should be softwood of partially seasoned stock to avoid swelling or warping. Timber which may be used for making strong scaffolding, beams, columns, props and bracings shall conform to IS 883.

6.1.2 Plywood

Plywood conforming to IS 4990 may be used for form lining, sheathing and panel.

6.1.3 Steel

Steel sheet plates conforming to IS 2062 or IS 8500 or

IS 1977 may be used for form and form lining and rolled sections and tubes conforming to IS 2062 or IS 8500 or IS 1161 may be used for steel forming and bracings.

Whenever proprietary systems are intended to be used, technical information as per Annex B should be obtained from the manufacturer beforehand. Steel clamps and couplers shall conform to IS 2750.

6.1.4 Other Materials

Other materials which may be used in falsework include aluminium, PVC, reinforced plastics, high density polyethylene, polypropylene, ferro-cement and polythene sheet for lining, etc. In certain applications, masonry, concrete and earthwork may be used as part of falsework.

6.2 Falsework Accessories

6.2.1 Form Ties

Form ties (see Fig. 1) may be used in the form of variety of threads and wing nuts having varying diameter from 10 to 30 mm and of a suitable length as per the requirements of each job. A plastic tube may be used covering the tie for easy removal of the tie after concrete is set.

The form ties may be fitted with plastic or wooden sleeving cones at each end. Ties may also be used in association with concrete blocks with central holes.

The part of form tie, if left inside the concrete, shall have minimum cover as specified for reinforcement.

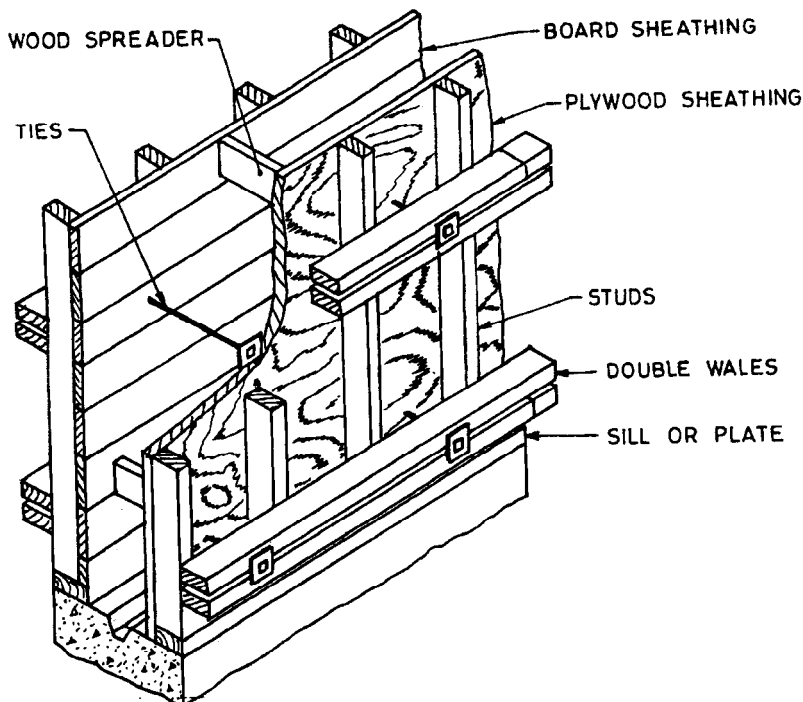

FIG. 1 TYPICAL WALL FORM SHOWING WALL TIES

6.2.2 Form Anchors

Form anchors should be embedded during concrete placement at specified locations in case formwork for the next lift is to be secured to the concrete being placed. The securing of formwork should be done only after the previously placed concrete has gained adequate strength.

6.2.3 Form Hangers

Form hanger (see Fig. 2) devices may be used for hanging formworks loads from structural steel or precast concrete structural members or other members.

6.2.4 Form Jacks

These proprietary systems may be used to facilitate supporting of the formwork from the lower flanges of steel beams (as an alternate to hanging the forms.)

6.2.5 Spreaders, Spacers

These devices may be used to keep forms in the proper position and to maintain a correct spacing between vertical form and reinforcing bars. These may be made of high strength mortar (vibrated or pressed), concrete, various grades of plastic, steel, etc.

6.2.6 Column Clamps

The column clamps may be used to hold the column form together and to resist the lateral pressure of the freshly poured concrete.

6.2.7 Sealing Strip

T-strips made of PVC sections and dimensions ranging from 15 mm to 40 mm may be used for sealing

the joints between the faces of formwork against leakage of mortar or slurry.

6.2.8 Chamfer Fillets

Proprietary fillets made of PVC to provide chamfers of various dimensions from 10 to 30 mm may be used.

6.2.9 Adjustable Steel Props

Adjustable steel props may be used.

6.3 Formwork Coatings and Releasing Agents

Formwork in contact with concrete may be treated with a coating or releasing agent of approved composition. The type of coating and its composition depends upon the type of shuttering material used and its surface which would be in contact with concrete. Coating and release agent should:

- provide a clean easy release or strike without damage to either the concrete face or the form,
- contribute to the production of blemish free concrete surface,
- have no adverse effect upon either the form or concrete,
- be easy to apply evenly at the recommended coverage, and
- not inhibit adhesive of any finish applied to the formed surface.

6.3.1 Shuttering should be coated with suitable form release agents for easy stripping, before each use. The form release agents are temporary coatings consisting of fatty acids which react with the alkali

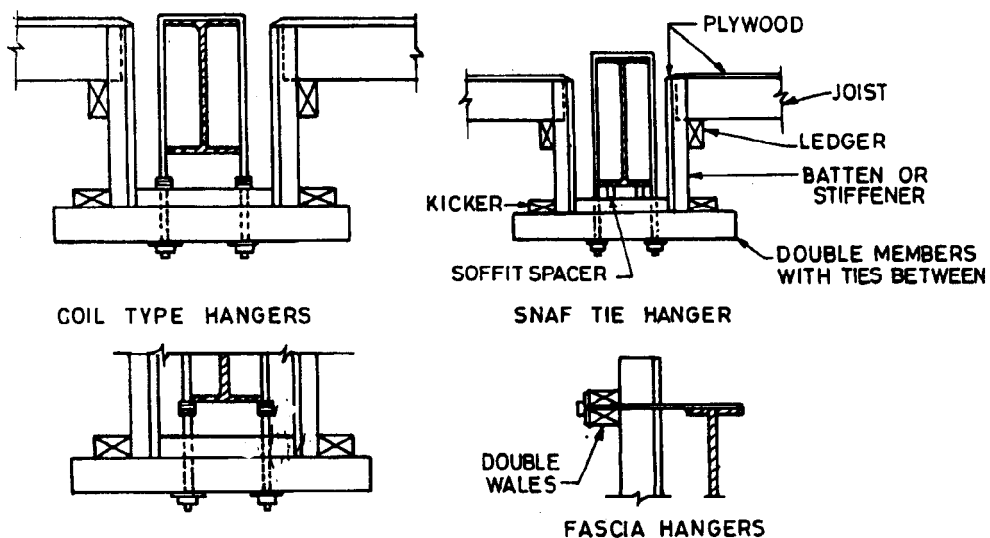

FIG. 2 TYPICAL BEAM ENCASEMENT FORMS, SHOWING BOTH COIL AND SNAP TYPE HANGERS

in cement and leave behind a soap like substance on the contact surface. This helps release of the form. These may be oils, emulsified wax, oil phased emulsions with water globules, petroleum based products, catalysed polyurethane foam, etc.

5.3.2 Careful consideration should be given to the choice of release agent taking account of the type of surface to which it is to be applied, the conditions under which it is to be used, the type of concrete, the quality of finish, the area of form and the ease of application.

The conventional use of waste oil as release agent should not be encouraged since it does not contain fatty acids.

7 DESIGN OF FALSEWORK

7.1 General

Falsework shall be designed to meet the requirements of the permanent structure using relevant Indian Standards for materials selected for falsework. The design should take into account the conditions of materials to be actually used for the falsework, environment and site consideration.

The checks for safety, overturning, overall stability and progressive collapse shall be implicit in design.

The falsework scheme shall preferably be so designed that the vertical members are subjected to compressive force only under the action of combined horizontal and vertical loads. The design should also take into account the sequence of concreting, specially in construction of cantilevers, domes, etc.

7.2 Design Information

Before proceeding to the design, all the relevant design information should be obtained from the relevant sources. The design information includes the site investigation report, expected loading scheme of load transfer, sequence of erection and releasing, procedure of concreting and time frame.

7.3 Loads on Falsework and Combination of Loads

7.3.0 General

Falsework shall be designed to resist the expected dead load, imposed load, environmental load and construction load.

Loads on falsework are any combinations of the following:

- a) Dead loads,
- b) Imposed loads,
- c) Environmental loads,

- d) Incidental loads during erection and operation, and
- e) Lateral pressure.

7.3.1 Dead Loads

7.3.1.1 Dead loads shall include :

- a) falsework structure, self weight of formwork and any ancillary temporary work connected or supported by formwork, and
- b) weight of freshly placed concrete for the permanent structure directly supported by the formwork; self load shall be determined either by actual measurement or in accordance with IS 875 (Part 1). The unit weight of wet concrete including reinforcement shall be taken as 26 kN/m³.

Additional weights of fittings shall be included in the self weight calculation.

7.3.1.2 Actual load of formwork shall be evaluated for use in design. However, in absence of the data, load may be assumed as 500 N/m² for the purpose of initial calculations.

7.3.2 Imposed Loads

7.3.2.1 General

Loads during constructional operation shall constitute the imposed loads [see IS 875 (Part 2)] for falsework design. Such loads may occur due to construction personal, plant and equipments, vibration and impact of machine delivered concrete, lateral pressure of fresh concrete, unsymmetrical placement of concrete, concentrated load and storage of construction materials. Imposition of any construction load on the partially constructed structures shall not be allowed unless specified in the drawings or approved by the engineer-in-charge. Allowance shall be made in the falsework design to accommodate force or deformation in the post tensioned members.

7.3.2.2 For this loading allowance to be valid, the concrete should not be dropped from a free height greater than 11 m, nor should be concrete allowed to keep and accumulate on the formwork to a height more than three times the depth of the slab, with a limit in area of 1 m² for any such situation to this height. If it be necessary to exceed these limitations, allowances for the additional loading should be made in design.

Where allowance has only to be made for access and inspection purposes, a loading of 750 N/m² should be adequate.

7.3.2.3 Load from the permanent works shall be assessed from the self weight of the permanent

structure to be supported by the formwork including the weight of plastic concrete which may actually be determined or taken as per IS 875 (Part 1). The effect of impact or surge wherever it may occur shall be suitably considered and catered for. Where pumping is resorted to, additional loads should be considered in design.

7.3.2.4 Lateral pressure due to fresh concrete

The lateral pressure due to fresh concrete depends on the temperature of concrete as placed, the rate of placing of concrete and the concrete mix proportion. A set of curves giving typical values of pressure P_{max} for unit height, on formwork are given in Fig. 3 for guidance.

For variation in the parameters appropriate correction factors as indicated in Table 1 are applicable for working out values from Fig. 3.

- a) *Workability* — Correction factors as given in Table 1 should apply.

Table 1 Correction Factors for Different Degree of Workability of Concrete

Degree of Workability	Rate of Placement of Concrete m/h		
	Up to 1	1.5 - 2	2.5 - 4
Very low	0.70	0.75	0.80
Low	0.80	0.85	0.90
Medium	1.00	1.00	1.00
High	1.10	1.30	1.50

- b) *Cement Content* — For every 50 kg increase in cement content beyond 350 kg/m³, the rate of placement of concrete may be reduced by 0.5 m/h for obtaining the correction to pressure.
- c) *Density of Concrete* — The curves are based on concrete density of 24 kN/m³. For other densities the values of P_{max} shall have to be pro-rated.
- d) *Type of Cement* — Where cement other than 33 grade ordinary Portland cement is used, appropriate allowance can be made for increasing or decreasing the value P_{max} as the case may be, depending on the relative setting times of concrete.
- e) *Admixture* — The curves are valid for concrete without use of any admixture, where admixtures are contemplated, trials or manufacturers data will be required to determine the effect of admixtures on the values of pressure.

The pressure distribution along the height of formwork can be assumed as given in Fig. 4. For normal concrete, the maximum pressure may occur at a height h_m below the top as given by the following formula:

$$h_m = P_{Max}/d$$

where

h_m is in m, P_{Max} is in kN/m², and

d is density of fresh concrete in kN/m³.

The pressure exerted on back form (that is top form on inclined surfaces) can uplift the formwork. Such situation should be designed and detailed for anchorage and pressure containment without movements.

7.3.3 Environmental Loads

These loads include:

- Wind or seismic loads,
- Earth pressure,
- Water pressure,
- Snow loads or ice loads, and
- Thermal load, etc.

7.3.3.1 Wind loads should be taken for design in accordance with IS 875 (Part 3) subject to a minimum horizontal load equal to 3 percent of the vertical loads at critical level.

7.3.3.2 Snow loads should be assumed in accordance with IS 875 (Part 4).

7.3.3.3 Ice loads are required to be taken into account in the design of members of formwork in zones subjected to ice formation. The thickness of ice deposits may be taken to be between 3 mm and 10 mm depending upon the locations of the formwork. The maximum density of ice may be assumed to be 900 kg/m³.

7.3.3.4 Earth pressure can occur on falsework as in the case of retaining walls and these shall be catered for. The rise in the water table may increase pressure on the falsework.

7.3.3.5 Shrinkage and early thermal movements in the freshly placed concrete should be assessed and accommodated in the design of formwork.

7.4 Permissible Stresses

Permissible stresses shall not exceed the values specified in the relevant Indian Standards for permanent structures.

In case of reusable components of steel, timber, etc,

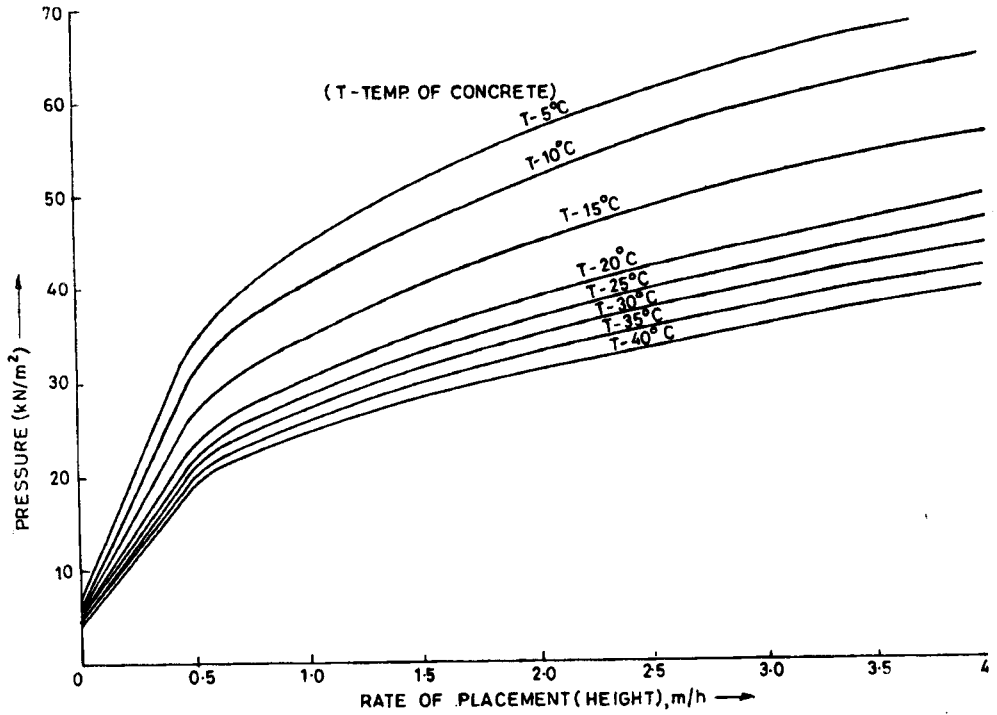

FIG. 3 MAXIMUM PRESSURE ON FORMWORK DUE TO FRESH CONCRETE

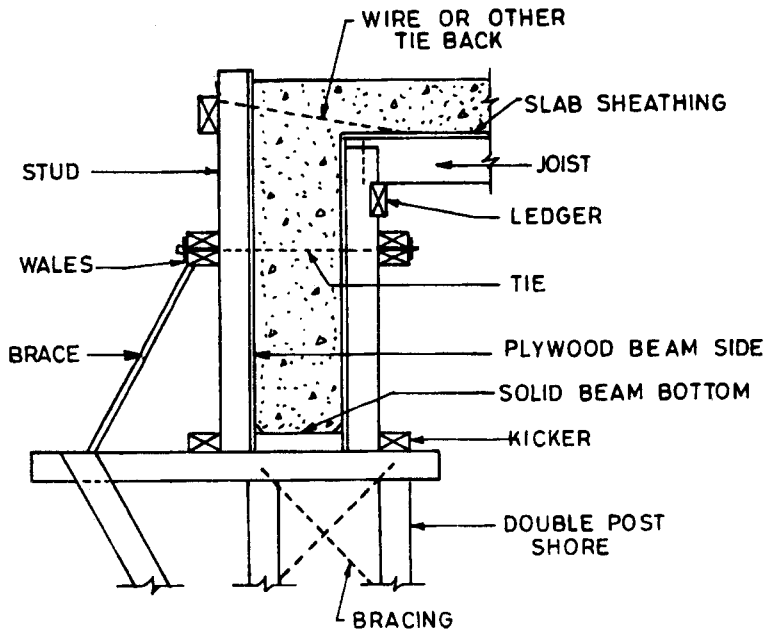

FIG. 4 TYPICAL STUD AND WALE FORMING FOR A SPANDREL BEAM WITH BRACING

the values of permissible stresses shall be suitably reduced depending upon the number of uses and extent of deterioration (*see* 7.4.4).

7.4.1 Timber

Basic permissible stresses of different species of timber selected out of timbers listed in IS 399, shall be taken in accordance with the stresses given in IS 883.

7.4.2 Plywood

Maximum permissible stresses and modulus of elasticity shall be in accordance with the provisions of IS 4990.

7.4.3 Steel

The permissible stresses shall be assumed as given in IS 800 and IS 2750, as applicable.

7.4.4 Tubular Section

The permissible stresses shall be assumed in accordance with IS 806. In case of reused steel tubes the permissible compressive stresses may be reduced by 15 percent provided the maximum reduction in nominal mass (*see* IS 1161) is 7.5 percent and the deviation in length is not more than 1/600 of the length.

7.4.5 Brickwork-Stone

The properties of brickwork, stone masonry and blockwork shall be as per IS 1905, IS 1597 (Part 1) and IS 2212.

7.4.6 Concrete

The concrete should in general comply with the requirements of IS 456 as appropriate to a concrete member.

Blinding concrete, where used shall have a minimum thickness of 50 mm of grade M10. If concrete of lower strength is used minimum thickness shall be 75 mm.

7.5 Deflection Limit

The formwork shall be designed so as to remain sufficiently rigid during placing and compaction of concrete. The total calculated deflection (δ) of falsework including the initial imperfection in the members shall not exceed the following:

- a) For beam span $< 3\ 000$ mm

$$\delta \quad \triangleright \quad 3 \text{ mm}$$

- b) For beam length $> 3\ 000$ m

δ is the least of

- 1) 30 mm
- 2) $L/1\ 000$

7.6 Stability

The formwork shall be designed to check against overturning and sliding. A factor of safety of 1.5 may be used in design against overturning and sliding.

7.7 Forces Resulting from Erection Tolerances

The acceptable erection tolerances on a nominally vertical members result in horizontal erections in association with the applied vertical forces.

Provided the maximum permissible erection tolerances are not exceeded, and the centroid of the member applying the vertical forces is not more than 25 mm in plan from the centroid of the foot of the supporting vertical member, provision should be made for a horizontal reaction equal to 1 percent of the applied vertical forces. These recommendations relate to individual tubes, props and structural steel sections and to proprietary components used as support towers.

7.8 Forces Resulting from Members Out of Vertical Design

Falsework members (for example beams or supports) may be designed to follow gradients or profiles and the members installed out of vertical by design. The vertical forces transmitted by the members will give horizontal components that require to be resisted in addition to other forces.

7.9 Bracing

7.9.1 The formwork system should be designed to transfer all horizontal loads to the ground or to completed construction in such a manner as to ensure safety during construction. Diagonal bracings (*see* Fig. 5) should be provided in vertical and horizontal plane to resist lateral loads and to prevent instability of individual members.

7.9.2 Bracing should be provided where restraint is actually required and should be as close to the point of application of vertical and horizontal forces and at the intersection of vertical and horizontal members.

7.10 Foundation

7.10.1 Proper foundations on ground such as mudsills, spread footings or pile footings shall be provided depending upon the support conditions. If soil under mudsills is or may become incapable of supporting superimposed loads without appreciable settlement, it should be stabilized or other means of support should be provided.

7.10.2 Falsework should be so designed and constructed that vertical adjustment can be made to compensate for taking up any foundation settlement.

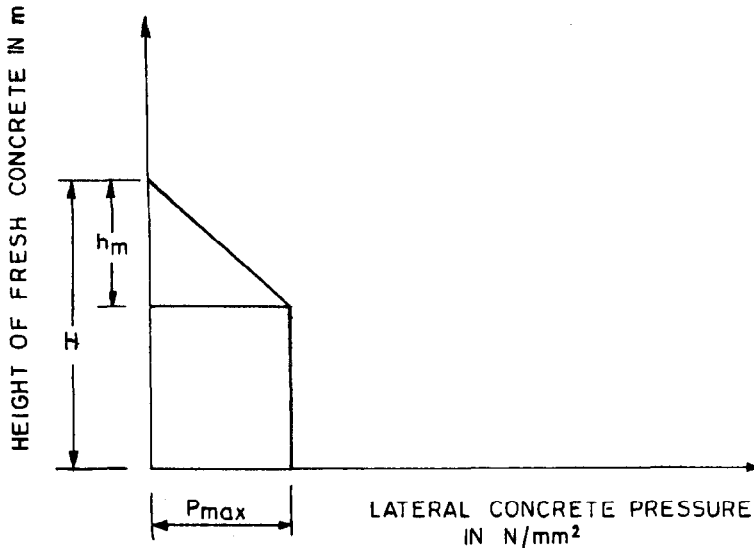

FIG. 5 PRESSURE DISTRIBUTION

Where the vertical load from the formwork are transferred to a permanent work such as slab, foundation, etc, a check should be made that these permanent structures can safely receive this loading without uneven ground pressure, deflection and settlement.

7.10.3 The loads from the formwork supported on the ground shall be applied to the ground through distribution members made of timber, steel base plate or precast concrete.

7.10.4 When it is required to proceed with the upper storey construction before the floor below has developed required strength, or its strength is not enough to withstand the construction loads including dead and live loads, the falsework below the lower floors should be retained or it should be reproped, ensuring that the props are directly one under the other so as to stress the lower floors to the minimum and within the permissible limits. In any event, shock loading through the falsework to the structure below shall be avoided. Also the lower props shall be checked against buckling.

7.11 Common Deficiencies in Design

Following common design deficiencies leading or contributing to failure should be avoided:

- a) Lack of allowance in design for such loadings as wind, power buggies placing equipment and temporary material storage;
- b) Inadequate anchorage against uplift due to battered form faces;
- c) Insufficient allowance for eccentric loading due to placement sequence;

- d) Failure to investigate bearing stresses in members in contact with shores and struts;
- e) Failure to provide proper lateral bracing or lacing of shoring;
- f) Failure to investigate the slenderness ratio of compression members;
- g) Inadequate provisions to tie corners of intersecting cantilevered form together;
- h) Failure to account for loads imposed on anchorages during gap closure in aligning formwork;
- j) Inadequate reshoring; and
- k) Overstressed reshoring.

8 SHUTTERING FOR CONCRETE AND OTHER DETAILING

8.1 Footings

Sloped footings will normally require formwork for vertical sides only. If the slope of the top faces exceeds angle of repose of the vertical concrete, formwork may be required for the top face.

Stepped footings may be provided to avoid the top form.

8.2 Columns

Column forms (see Fig. 6) should be capable of being stripped easily. In tall forms it is desirable to provide windows at appropriate levels on at least one face to facilitate inspection, concrete placement and vibration.

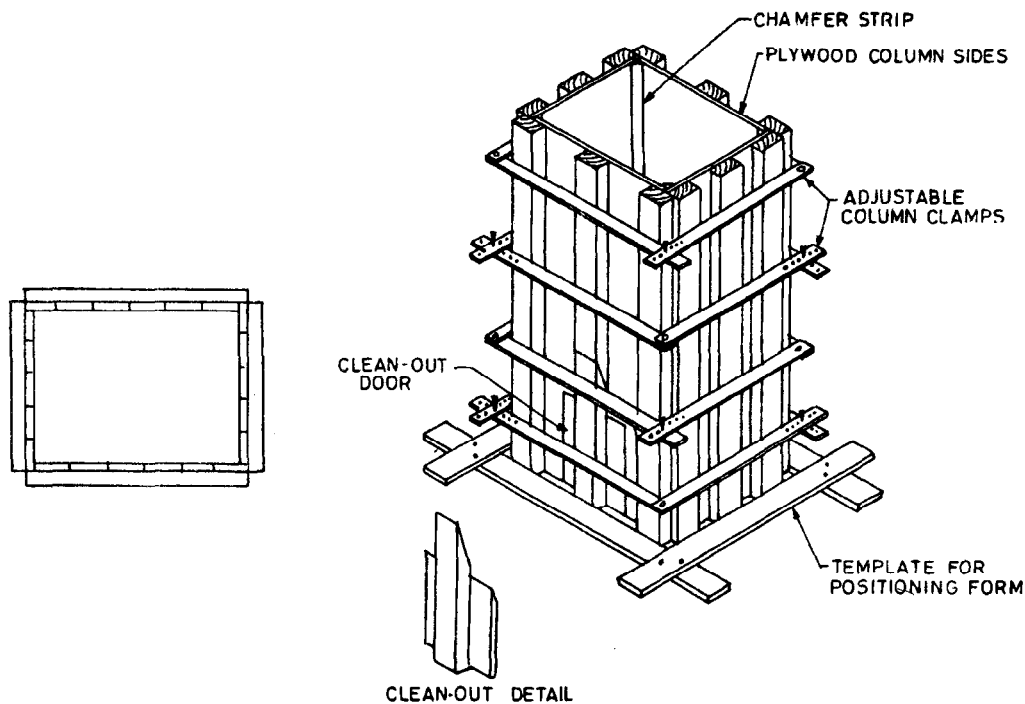

FIG. 6 TYPICAL CONSTRUCTION OF HEAVIER COLUMN

Any method (standard or patented) such as adjustable clamps, bolts, purpose made yokes, etc. to hold the panels in place may be used. The spacing and size of these clamps shall depend upon the lateral pressure of fresh concrete.

8.3 Walls

The shuttering shall be fixed at required distance equal to the required wall thickness. The two faces of shutters of the wall should be kept in place by appropriate ties with spacer tubes or bolts, braces and studs (*see* Fig. 1).

8.4 Beams and Floor Slabs

When single post prop is used, it should be adequately braced and connected to the nearest props (*see* Fig. 7 and Fig. 8).

8.5 Inclined Members

Members inclined to horizontal may have a single bottom shuttering if the angle of inclination is less than or equal to 40° . Otherwise double shuttering shall be required.

8.6 Timber Connections

Bolting is preferred to nail joints to avoid damage to formwork material. The splices can be made by using a pair of mild steel or timber fishplates connected with bolts in timber. The splice piece should be at least 600 mm long, 50 mm thick with width not less than the width of the prop.

9 SITE OPERATION

9.1 Safety Precaution

Construction procedures should be planned in advance to ensure the safety of personnel and equipments and the integrity of the finished structure. Some of the safety provisions which should be considered are:

- Erection of safety signs and barricades to keep unauthorized personnel clear of areas in which erection, concrete placing, or stripping is under way.
- Providing experienced form watchers during concrete placement to assure early recognition of possible form displacement or failure. A supply of extra shores or other material and equipment that might be needed in an emergency should be readily available.
- Provision for adequate illumination of the formwork and work area.
- Inclusion of lifting points in the design and detailing of all forms which will be crane handled. This is especially important in flying forms or climbing forms. In the case of wall formwork, consideration should be given to an independent scaffold bolted to the previous lift.
- Incorporation of scaffolds, working platforms,

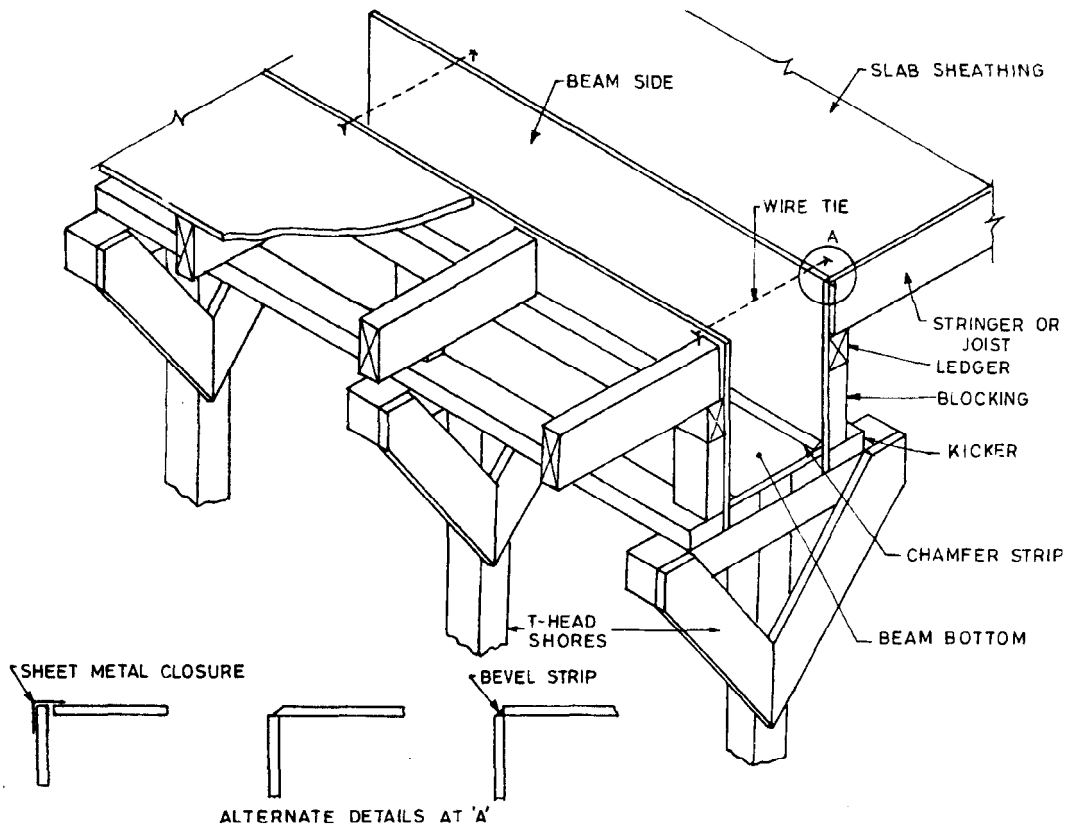

FIG. 7 TYPICAL COMPONENTS OF BEAM FORM WORK WITH SLAB FRAMING IN

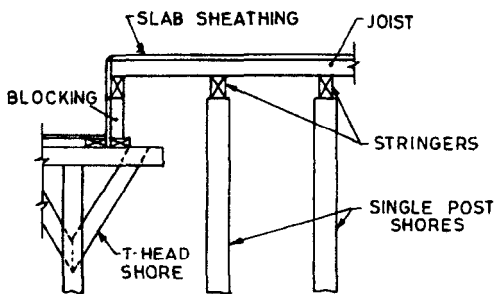

FIG. 8 TYPICAL SLAB FORM RESTING ON BEAM LEDGER AND STRINGERS

and guard rails into formwork design and all formwork drawing.

- f) A programme of field safety inspections of formwork.
- g) In case structural elements such as cantilever, beams/slabs, where overturning is an important parameter, stripping of formwork shall be done only after mobilization of full restraining forces.

9.2 Erection of Falsework

Following should be checked during erection of falsework:

- a) All provisions of the design and drawings should be complied with.
- b) Any member, which has to remain in position during or after the general releasing of falsework, should be clearly marked.
- c) The materials used should be checked to ensure that undesirable or rejected items are not used.
- d) Any excavations nearby which can influence the safety of the falsework, should be accounted for in the planning.
- e) The bearing soil should be sound and suitably prepared. The sole plates should fully bear on the ground, without possible settlement.
- f) Safety measures should be taken to prevent impact of traffic, scour due to water, etc.
- g) Adequate bracings, struts and ties should be installed with the progress of erection to ensure strength and stability of falsework at intermediate and final stages.
- h) Inclined forms, which give rise to very high horizontal forces should be taken care of by trussing and diagonal bracing (see Fig. 9).

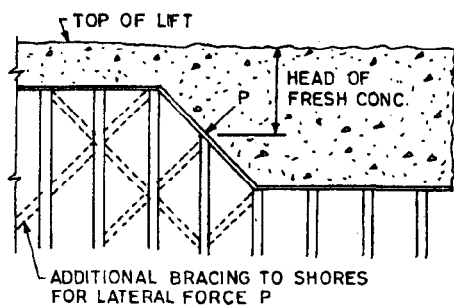

FIG. 9 SIMPLIFIED DRAWING OF INCLINED SLAB FORM WITH SUPPORTING SHORES

- j) The places of stacking of materials should be marked as per provision in falsework design and it should be ascertained that the stacking is done only at proper places.
- k) The deterioration of materials due to storage, reuse and misuse should be checked and corrective steps taken for safety.
- m) Wedges should be provided for adjustment of the falsework to the required position, after any settlement or elastic shortening of props occur.
- n) The inclined plane of the wedges should not be too steep and the pair should be nailed down after adjustment to prevent their shifting. A pair of two matched and equal wedges should be used in opposition, and not one wedge only by itself. The wedges should not induce eccentricity.

9.3 Reuse and Maintenance of Formwork

9.3.1 Timber Formwork

Timber should be generally examined for any visible damage during use and be discarded or its safe capacity suitably reduced if any of the following is present:

- a) Signs of rot.
- b) Cuts on the edge greater than 1/20 of the thickness of the section.
- c) Bolt holes in the two outer third lengths or width.
- d) Undue distortion of shape.
- e) Any other mechanical damage.
- f) Splitting.

9.3.2 Metal Formwork

Forms which are to be reused shall be carefully cleared and properly repaired between uses. Concrete or

mortar film sticking to the form face or the joining surface shall be completely removed after each use when not required for use, the formwork material shall be properly stored. The component shall be cleaned and painted periodically. Threaded parts shall be oiled or greased after thorough clearing and removal of dirt or slurry. Free movement of the telescopic components shall be ensured by periodic cleaning/oiling.

9.4 Concreting Operations and the Application of Loads

Following shall be checked, before and during concreting operations or load application:

- a) Adequate access ramps, gangway, etc in the proper positions are provided for the smooth flow of men, materials and machines.
- b) All precautions are taken to prevent accidental impact, scouring or flooding of foundations. Adequate precautions should also be taken to keep unauthorised people away from the falsework.
- c) The forms shall be clean and free from wood shavings, grit, etc.
- d) Forms and joints are such that they prevent leakage of mortar and slurry.
- e) Only approved coating or form release agent are applied, and the reinforcement are clean from the same.
- f) The sequence, rate of concreting, and method of placement and position of construction joints are as per the design brief.

In some cases, the load of fresh concrete and the live load at one place may cause uplift of the forms at another place and thus result in displacement of the forms and danger to the props by losing wedges, etc. Positions of such possibilities be checked.

- g) The reinforcement and falsework have been checked and permission to commence the placement of concrete has been accorded.
- h) The thickness of the concrete are maintained all along the member as per drawing, even when camber have been provided.
- j) The props and bracings should be watched during the placement of concrete and its vibration. Any members or wedges which may tend to become loose or shift should be attended immediately. An agreed system of communication between the man below and the man in charge of concrete operations

should be established so that corrective actions as required may be taken and concreting can be stopped instantly if at all it becomes necessary to do so.

- k) Platforms for the movement of workers and mechanized concrete buggies are separate and are not placing load upon the reinforcing steel. If this is unavoidable, steel chairs should be placed under the reinforcement at adequate spacing to prevent deformation of the reinforcement.

9.5 Stripping of Falsework (Also releasing or dismantling or removing or de-shuttering of formwork)

9.5.1 Soffit falsework shall not be released until the concrete has achieved a strength of at least twice the stress to which the concrete may be subjected, at the time of removal. The strength referred to shall be that of concrete using the same cement, aggregates and admixture, if any with the same proportions and cured under conditions of temperature and moisture similar to those existing on the work.

While the above criteria of strength shall be the guiding factor for removal of formwork, in normal circumstances where ambient temperature does not fall below 15°C and where ordinary Portland cement is used and adequate curing is done, following striking period may deem to satisfy the guideline:

Vertical formwork to columns, walls, beam	16-24 h
Soffit formwork to slabs (props to be refixed immediately after removal of formwork)	3 days
Soffit formwork to beams (props to be refixed immediately after removal of formwork)	7 days
Props to slabs:	
a) Spanning up to 4.5 m	7 days
b) Spanning over 4.5 m	14 days
Props to beams and archer	
a) Spanning up to 6 m	14 days
b) Spanning over 6 m	21 days

For other cements and lower temperature, the stripping time, recommended above may be suitably modified. When formwork to vertical surface, such as beam sides, walls and columns, is removed at early ages, care should be exercised to avoid damage to the concrete especially to arises and features. If necessary, the provision of relevant curing methods should immediately follow the removal of the vertical

formwork at such age and the concrete should be protected from low or high temperatures by means of suitable insulation.

Supporting forms and shores must not be removed from the beams, floors and walls until these structures/units are strong enough to carry their own weight and any approved superimposed load. Supporting forms and shores should not be removed from the horizontal members before concrete strength is at least 70 percent of design strength.

As a general rule, the forms for columns and piers may be removed before those for beams and slabs. Formwork and supports should be so constructed that each can be easily and safely removed without impact or stuck to permit the concrete to carry its share of the load gradually and uniformly.

9.5.2 Following should be checked before and during release of falsework :

- a) The person concerned and the workers are in the knowledge of the sequence of releasing of forms and the props to be left in position.
- b) All falsework material are properly stacked and maintained in good condition. Any items which may be damaged or wrecked while stripping are segregated. Any member should not be allowed to be dropped from a height but should be carefully brought down.
- c) Forms are eased off from concrete faces such as to prevent damage to both concrete and forms.
- d) The sequence of dismantling, as laid down, are adhered to. If not laid down, the sequence are planned by the agency doing falsework, and that are safe for the workers and the permanent construction.

9.6 Tolerance in Formwork

The formwork shall be such that the finished concrete shall be in the proper position in space measured with respect to certain predefined reference points. Formwork should be of the proper dimensions and shape as per drawings. The tolerances on the shape, lines and dimensions shown in the drawing shall be within the specified limits given below:

- a) Deviation from specified dimensions of cross-section of columns and beams
 - 6 mm
 - + 12 mm
- b) Deviation from dimensions of footings
 - 1) Dimensions in plan
 - 12 mm
 - + 50 mm

- 2) Eccentricity 0.02 times the width of the footing in the direction of deviation but not more than 50 mm
- 3) Thickness ± 0.05 times the specified thickness

9.7 Accuracy of Falsework

Unless otherwise specified, the limiting criteria recommended in 9.7.1 and 9.7.2 should not be exceeded on site.

9.7.1 Adjustable Steel Props and Forkheads

The following limiting factors are appropriate to adjustable steel props:

- Props should be undamaged and not visibly bent.
- Props should be plumb within 1.5° of vertical (that is, not exceeding 25 mm out of vertical over a height of 1 m).
- Props should be placed centrally under the member. To be supported and over any member supporting the prop, with no eccentricity in excess of 25 mm.

9.7.2 Tube and Coupler Falsework

In case of tube and coupler falsework the following factors should apply:

- The tubes used in falsework should be undamaged, not visibly bent or creased and have smooth square cut ends. Other components should also be undamaged.
- Vertical should be plumb within 15 mm over 2 m of height, subject to a maximum displacement for the vertical of 25 mm.
- Vertical members should be placed centrally under the members to be supported and over the member supporting them with no eccentricity exceeding 25 mm.
- Adjustable forkhead and baseplates should be adequately laced or baced where their extension exceeds 300 mm, unless an alternative figure is specified. The bracing tubes should be attached close to the fork or baseplate and to an adjacent vertical member, close to the lacing.
- Tubes should have end-to-end joints in adjacent tubes staggered. Sleeve couplers

should be used in preference to joint pins for axial connections.

- The centrelines of tubes at node point should be as close together as possible, and never more than 150 mm apart.
- Sole plates used to distribute falsework loads on the foundation soils should normally be set horizontally within a tolerance not exceeding 25 mm in a length of 1 m.

9.7.3 Fabricated Steel Works

The following tolerances should be adopted for purposely fabricated steelwork:

- Inclination of a column from vertical (see Fig. 10)
 - for column of length $L_c < 1450$ mm
 $\Delta v \geq 5$ mm
 - for column of length $L_c > 1450$ mm
 $\Delta v \geq 0.0035 L_c$, or 25 mm, whichever is the lesser

where

L_c = clear length of strut or column (in mm),
and

Δv = inclination from vertical (in mm).

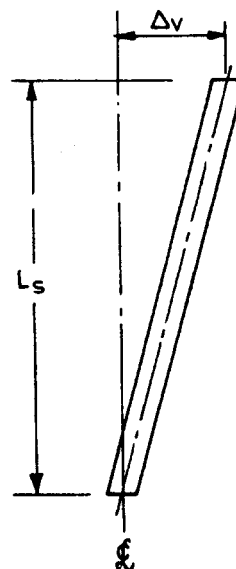

FIG. 10 INCLINATION OF A COLUMN FROM VERTICAL

- Out of straightness of a strut or column (see Fig. 11)
 - for a column or strut of length L_s < 3350 mm
 $\Delta_s \geq 5$ mm

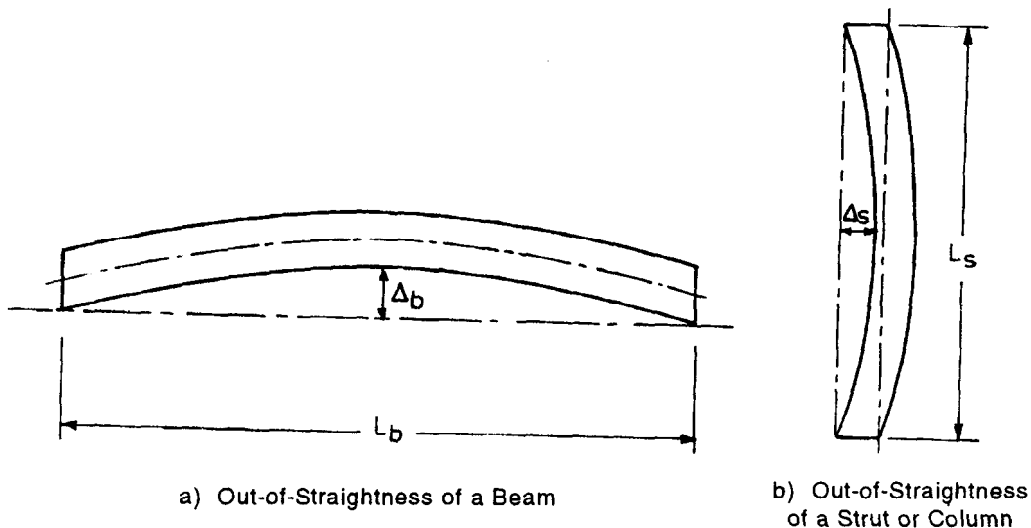

FIG. 11 POINTS OF MEASUREMENT OF TOLERANCES FOR PURPOSELY FABRICATED STEEL WORK

2) for a column or strut of length L_s , $L_s > 3350$ mm

$$\Delta_s \geq 0.0015 L_s \text{ or } 25 \text{ mm, whichever is lesser}$$

where

L_s = clear length of strut or column (in mm), and

Δ_s = out of straightness of the column or strut (in mm).

c) Eccentricity of beam bearing

The eccentricity of any beam should not exceed 5 m.

9.8 Checking

9.8.1 Formal checks are recommended:

- a) When the proposed founding level for the falsework is in preparation;
- b) When the falsework has attained a height of 10 m or a height equal to 1.5 times the minimum of its plan dimensions;
- c) When the falsework reaches its support level;
- d) At intermediate stages, when the strength or stability of the falsework may have been adversely affected by environmental or other loading conditions or unauthorized interference;
- e) Where equipment is being continually reused and periodic checks are appropriate; and
- f) Immediately prior to load being applied.

9.8.2 At the stages indicated in 9.8.1 thorough inspection of the falsework is necessary to ensure that the completed structure will function as indicated.

The inspection should be undertaken with direct reference to any drawing or specification that has been issued, and checks subsequently to the first should inspect every feature that could have altered in the intervening period.

a) *General*

- 1) All the drawings and written instructions have been strictly complied with;
- 2) Only the correct materials in serviceable conditions have been employed, specially of specific types or qualities required as will normally be the case with structural steel or timber.

b) *At ground level*

- 1) the setting out is correct;
- 2) the ground has been adequately prepared and at a satisfactory level (foundations appearing sound in dry or freezing conditions can be quite inadequate following rain or thaw);
- 3) suitable sole plates or other bases have been provided and have been properly levelled;
- 4) sole plates or other bases have not settled;
- 5) sole plates have been properly bedded down (no cavities underneath), and steps

taken to prevent erosion;

- 6) sole plates and other load-distributing members laid on the slope are adequately prevented from movement down the slope;
- 7) any checks or other supports are of the correct shape, and are adequately secured;
- 8) base plates have been used and are properly spaced and centred on the sole plates; and
- 9) the extension of each screw or adjustable base is within the permitted limits, and braced, if necessary.

c) Above ground level.

All the points applicable for the falsework above the ground, mentioned in 9.2, shall be checked.

9.9 Check List

Following is the check list which may be used by foremen, supervisors and inspectors of falsework. Actual points to be checked should be suited to job conditions and will vary for different types of construction.

- a) When adjustable steel props are used, these should be
 - 1) undamaged and not visibly bent,
 - 2) having the steel pins provided by the manufacturer for use,
 - 3) restrained laterally near each end, and
 - 4) have means for centralizing beams placed in the forkheads.
- b) Sole plates are properly seated on their bearing pads or sleepers.
- c) The screw adjustments of adjustable props have not been over-extended.
- d) Horizontal load bearing members are not eccentric upon vertical members.
- e) Steel sections (specially deep sections) are adequately restrained against tilting and overturning.
- f) There are enough restraints in the falsework

against horizontal loads.

- g) All securing devices and bracing are tightened.
- h) Standard components of proprietary systems are used. This particularly applies to pins.
- j) Adequate measures are taken to prevent accidental impacts, etc.
- k) Washers under all bolts heads and nuts have adequate bearing area.
- m) Steel parts on timber members should have adequate bearing areas.
- n) There should be no splitting of timber due to nailing and the number of nails and bolts should be adequate.
- p) The cantilever supports should be more than adequate and be rechecked.
- q) Bolted timber connections are staggered where necessary.
- r) Supports are in plumb within the specified tolerance.
- s) Props are directly one under another in multistage or multistorey falsework.
- t) Bearing plates of props are not distorted and are flat.
- u) Guy ropes or stays are tensioned adequately.
- w) The dimensions of falsework are within prescribed tolerances.
- y) There are adequate provision for the movement and operation of vibrators and other construction plant.
- z) Cambers are provided as per drawings. This may be specifically needed for long spans and cantilevers.

Reporting and recording by experienced form watchers should be encouraged. A format as shown in Annex C may be used for maintaining such records.

ANNEX A

(Clause 2)

LIST OF REFERRED INDIAN STANDARDS

<i>IS No.</i>	<i>Title</i>	<i>IS No.</i>	<i>Title</i>
399 : 1963	Classification of commercial timbers and their zonal distribution (<i>revised</i>)	1597 (Part 1) : 1992	Code of practice for construction of stone masonry : Part 1 Rubble stone masonry (<i>first revision</i>)
456 : 1978	Code of practice for plain and reinforced concrete (<i>third revision</i>)	1905 : 1987	Code of practice for structural use of un-reinforced masonry (<i>third revision</i>)
800 : 1994	Code of practice for general construction in steel (<i>second revision</i>)	1977 : 1996	Low tensile structural steels (<i>third revision</i>)
806 : 1968	Code of practice for use of steel tubes in general building construction (<i>first revision</i>)	2062 : 1992	Steel for general structural purposes (<i>fourth revision</i>)
875	Code of practice for design loads (other than earthquake) for buildings and structures:	2212 : 1991	Code of practice for brickwork (<i>first revision</i>)
(Part 1) : 1987	Dead loads — Unit weights of building material and stored materials (<i>second revision</i>)	2750 : 1964	Specification for steel scaffoldings
(Part 2) : 1987	Imposed loads (<i>second revision</i>)	3337 : 1978	<i>BALLIES</i> for general purposes (<i>first revision</i>)
(Part 3) : 1987	Wind loads (<i>second revision</i>)	4990 : 1993	Specification for plywood for concrete shuttering work (<i>third revision</i>)
(Part 4) : 1987	Snow loads (<i>second revision</i>)	6461	Glossary of terms relating to cement concrete: Part 5 Form-work for concrete
883 : 1994	Code of practice for design of structural timber in building (<i>fourth revision</i>)	(Part 5) : 1972	
1161 : 1979	Steel tubes for structural purposes (<i>third revision</i>)	8500 : 1992	Structural steel — Microalloyed (medium and high strength qualities)

ANNEX B

(*Clauses 5.2 and 6.1.3*)**INFORMATION TO BE SUPPLIED BY THE MANUFACTURERS OF PROPRIETARY FALSEWORK SYSTEMS****B-1 INFORMATION TO BE SUPPLIED**

B-1.1 The manufacturer should give the information in such details so as to assist the user and to obviate unsafe use of the material due to absence of information or due to wrong assumptions made on the part of the user.

The user may refer unusual problems or problems of erection or assembly, which the manufacturer should clarify with all technical details.

B-1.2 The manufacturer of proprietary falsework systems or its parts shall supply the information necessary for the design, erection, use, dismantling and maintenance of the components.

The information should relate to the properties of the individual components, their use in expected assemblies, any specific requirements for inspection and maintenance; and should include the following:

- a) Identification, description and the intended use of the components, their dimensions and weights.
- b) Drawings of major components giving dimensions, extensibility, weight, locating and fixing arrangements. Locations of holes and cleats, etc, and any other details, of interest or use to designer or site engineers.
- c) Details and specifications of the materials used and reference to relevant standards.
- d) Modifications for extended or additional uses and limitations for every use should be given.
- e) Strength details of the component and assemblies, as given below:
 - 1) Characteristic (that is assured) failure loads;
 - 2) Maximum working loads for different conditions of use and extensions;
 - 3) Maximum eccentricities related to above conditions;
 - 4) Deflections and cambers at maximum working loads;
 - 5) Conditions of limiting deflection;
 - 6) Assumed working stresses and material properties, for example, yield stresses;
 - 7) Section properties;
 - 8) Information on design of sway bracing against lateral loads; and
 - 9) Degree of lateral restraint imposed at connections in the system.
- f) Tables for use of the components in normal applications.
- g) Maximum allowable wear and tear and defects due to long usage and life of the components where applicable.
- h) Erection methods, erection stages, erection tools, precautions and tests on the complete structure.
- j) Method of stripping or releasing the system. Suggested method of stacking and maintenance of the system.
- k) Detailed instructions on special or uncommon uses of the equipment.
- m) Special components and adjustment methods, for example, for centering members in fork-heads.

ANNEX C
(Clause 9.9)

**A TYPICAL FORMAT FOR REPORT FORM
WATCHERS REPORT**

Job location Date

Placement description: Floor General contractor

Placement number General contr.supt

Column line references

Starting time of placement

Completion time of placement

Concrete placing equipment

Concrete conveying equipment

Type of work being poured

Scope of sub-contractor's work

Type of formwork or structure to which sub-contractor's work is framed

Comments on general contractor's framing

List of points to check out before and during concrete placement

Form details for job

All shores in place

Wedges under shores tight and nailed

Shoring hardware secured

Sills solid on ground or slab

Lacing installed, when required

Pans nailed

Check for spreaders when required in joist pans

Plywood joints flush

X-bracing installed where lateral movement could occur

Beam spreader in place

Form hardware tight

Tighten wedges under shores along construction joint of previous pour

Check shores for plumb

Telltails in place and marked where required

Camber installed

Clean out holes patched

Chamfer and grade strips in place

Equipment available in case of need for adjustment or reinforcement :

- Extra jacks
- Extra lacing
- Extra shores
- Wedges
- Pre-arranged signal with concrete placing foreman to stop pour in emergency
- Check for possible exit routes in case of trouble — have at least two such routes available, wherever possible
- Know placing crews' sequence of pour, check for placing deep beams or drops before main deck
- For walls, know rate of placement for which forms designed and protest, if exceeded

ANNEX D

(Foreword)

COMMITTEE COMPOSITION

Cement and Concrete Sectional Committee, CED 2

Chairman

DR H. C. VISVESVARAYA
'CHANDRIKA' 63-64 East Park Road,
Malleswaram, Bangalore 180003

Members

SHRI H. BHATTACHARYA
SHRI G. R. BHARTIKAR
DR A. K. CHATTERJEE
SHRI S. H. SUBRAMANIAN (*Alternate*)
CHIEF ENGINEER (DESIGN)
SUPERINTENDING ENGINEER (S&S) (*Alternate*)
CHIEF ENGINEER, NAVAGAM DAM
SUPERINTENDING ENGINEER (QCC) (*Alternate*)
CHIEF ENGINEER, RESEARCH-CUM-DIRECTOR
RESEARCH OFFICER, CONCRETE TECHNOLOGY (*Alternate*)
DIRECTOR
JOINT DIRECTOR (*Alternate*)
DIRECTOR (CMDD) (N&W)
DEPUTY DIRECTOR (CMDD) (NW&S) (*Alternate*)
SHRI K. H. GANGWAL
SHRI V. PATTABHI (*Alternate*)
SHRI V. K. GHANEKAR
SHRI S. GOPINATH
SHRI R. TAMILAKARAN (*Alternate*)
SHRI S. K. GUHA THAKURTA
SHRI S. P. SANKARANARAYANAN (*Alternate*)
SHRI N. S. BHAL
DR IRSHAD MASOOD (*Alternate*)
DR IRSHAD MASOOD
SHRI N. C. JAIN (*Alternate*)

Representing

Orissa Cement Limited, New Delhi
B. G. Shirke and Company, Pune
The Associated Cement Companies Ltd, Mumbai
Central Public Works Department, New Delhi
Sardar Sarovar Nirman Nigam Ltd, Gandhinagar
Irrigation and Power Research Institute, Amritsar
A. P. Engineering Research Laboratories, Hyderabad
Central Water Commission, New Delhi
Hyderabad Industries Ltd, Hyderabad
Structural Engineering Research Centre (CSIR), Ghaziabad
The India Cements Ltd, Chennai
Gannon Dunkerley & Co Ltd, Mumbai
Central Building Research Institute (CSIR), Roorkee
Cement Corporation of India, New Delhi

(Continued on page 20)

(Continued from page 19)

<i>Members</i>	<i>Representing</i>
JOINT DIRECTOR STANDARDS (B&S)/CB-I JOINT DIRECTOR STANDARDS (B&S) CB-II (<i>Alternate</i>)	Research, Designs and Standards Organization (Ministry of Railways), Lucknow
SHRI N. G. JOSHI SHRI P. D. KELKAR (<i>Alternate</i>)	Indian Hume Pipes Company Ltd, Mumbai
SHRI D. K. KANUNGO SHRI B. R. MEENA (<i>Alternate</i>)	National Test House, Calcutta
SHRI P. KRISHNAMURTHY SHRI S. CHAKRAVARTHY (<i>Alternate</i>)	Larsen and Toubro Limited, Mumbai
DR A. G. MADHAVA RAO SHRI K. MANI (<i>Alternate</i>)	Structural Engineering Research Centre (CSIR), Chennai
SHRI G. K. MAJUMDAR SHRI J. SARUP (<i>Alternate</i>)	Hospital Services Consultancy Corporation (India) Ltd, New Delhi
SHRI PRAFULLA KUMAR SHRI P. P. NAIR (<i>Alternate</i>)	Ministry of Transport, Department of Surface Transport, Roads Wing, New Delhi
MEMBER SECRETARY DIRECTOR (CIVIL) (<i>Alternate</i>)	Central Board of Irrigation and Power, New Delhi
SHRI S. K. NATHANI, SO I DR A. S. GOEL, EE (<i>Alternate</i>)	Engineer-in-Chief's Branch, Army Headquarters, New Delhi
SHRI Y. R. PHULL SHRI S. S. SEEHRA (<i>Alternate</i>)	Central Road Research Institute (CSIR), New Delhi
SHRI Y. R. PHULL SHRI A. K. SHARMA (<i>Alternate</i>)	Indian Roads Congress, New Delhi
DR C. RAJKUMAR DR K. MOHAN (<i>Alternate</i>)	National Council for Cement and Building Materials, New Delhi
SHRI G. RAMDAS SHRI R. C. SHARMA (<i>Alternate</i>)	Directorate General of Supplies and Disposals, New Delhi
SHRI S. A. REDDI	Gammon India Ltd, Mumbai
REPRESENTATIVE	Builders' Association of India, Mumbai
SHRI J. S. SANGANERIA SHRI L. N. AGARWAL (<i>Alternate</i>)	Geological Survey of India, Calcutta
SHRI S. B. SURI SHRI N. CHANDRASEKARAN (<i>Alternate</i>)	Central Soil and Materials Research Station, New Delhi
SUPERINTENDING ENGINEER (DESIGN) EXECUTIVE ENGINEER (S. M. R. DIVISION) (<i>Alternate</i>)	Public Works Department, Government of Tamil Nadu, Chennai
SHRI A. K. CHADHA SHRI J. R. SIL (<i>Alternate</i>)	Hindustan Prefab Ltd, New Delhi
DR H. C. VISVESVARAYA SHRI D. C. CHATURVEDI (<i>Alternate</i>)	The Institution of Engineers (India), Calcutta
SHRI VINOD KUMAR, Director (Civ Engg)	Director General, BIS (<i>Ex-officio Member</i>)

Member-Secretary

SHRI J. K. PRASAD
Additional Director (Civ Engg), BIS

Concrete Subcommittee, CED 2 : 2

Convener

DR A. K. MULLICK

National Council for Cement & Building Materials, New Delhi

Members

SHRI C. R. ALIMCHANDANI
SHRI S. RANGARAJAN (*Alternate*)

Stup Consultants Ltd, Mumbai

DR P. C. CHOWDHARY
DR C. S. VISHWANATH (*Alternate*)

Torsteel Research Foundation in India, Calcutta

(Continued on page 21)

(Continued from page 20)

<i>Members</i>	<i>Representing</i>
SHRI J. P. DESAI SHRI B. K. JAGETIA (<i>Alternate</i>)	Gujarat Ambuja Cement Ltd, Ahmedabad
DIRECTOR SHRI N. CHANDRASEKARAN (<i>Alternate</i>)	Central Soil Materials Research Station, New Delhi
JOINT DIRECTOR STANDARDS (B&S)/CB-II JOINT DIRECTOR STANDARDS (B&S)/CB-I (<i>Alternate</i>)	Research, Design and Standards Organization, Lucknow
SUPERINTENDING ENGINEER (DESIGNS) EXECUTIVE ENGINEER (DESIGN) (<i>Alternate</i>)	Central Public Works Department, New Delhi
SHRI V. K. GHANEKAR SHRI D. S. PRAKASH RAO (<i>Alternate</i>)	Structural Engineering Research Centre, Ghaziabad
SHRI S. K. GUHA THAKURTA SHRI S. P. SANKARNARAYANAN (<i>Alternate</i>)	Gannon Dunkerley & Co Ltd, Mumbai
SHRI J. S. HINGORANI SHRI A. P. REMEDIOS (<i>Alternate</i>)	Associated Consulting Services, Mumbai
SHRI LALIT KUMAR JAIN	In personal capacity (<i>Consulting Structural Engineer, 36, Old Sneh Nagar, Wardha Road, Nagpur 440015</i>)
SHRI M. P. JAISINGH SHRI B. KAMESWARA RAO (<i>Alternate</i>)	Central Building Research Institute, CSIR, Roorkee
CHIEF ENGINEER & JOINT SECRETARY SUPERINTENDING ENGINEER (<i>Alternate</i>)	Public Works Department, Mumbai
PROF S. KRISHNAMOORTHY SHRI K. K. NAYAR (<i>Alternate</i>)	Indian Institute of Technology, New Delhi
SHRI S. C. MAITI DR ANIL KUMAR (<i>Alternate</i>)	National Council for Cement and Building Materials, New Delhi
MANAGING DIRECTOR SHRI M. KUNDU (<i>Alternate</i>)	Hindustan Prefeb Ltd, New Delhi
SHRI M. K. MUKHERJEE SHRI N. K. SINHA (<i>Alternate</i>)	Ministry of Transport (Road Wing), New Delhi
SHRI B. V. B. PAL SHRI M. G. DANDAVATE (<i>Alternate</i>)	The Associated Cement Co Ltd, Mumbai
SHRI A. B. PHADKE SHRI D. M. SAVUR (<i>Alternate</i>)	The Hindustan Construction Co Ltd, Mumbai
SHRI Y. R. PHULL SHRI S. S. SEEHRA (<i>Alternate I</i>) SHRI SATENDER KUMAR (<i>Alternate II</i>)	Central Road Research Institute (CSIR), New Delhi
SHRI A. S. PRASAD RAO SHRI K. MANI (<i>Alternate</i>)	Structural Engineering Research Centre (CSIR), Chennai
SHRI K. L. PRUTHI SHRI J. R. GABRIEL (<i>Alternate</i>)	National Building and Construction Corporation Ltd, New Delhi
SHRI B. D. RAHALKER SHRI U. S. P. VERMA (<i>Alternate</i>)	Nuclear Power Corporation, Mumbai
SHRI HANUMANTHA RAO SHRI G. RAMAKRISHNAN (<i>Alternate</i>)	A. P. Engineering Research Laboratories, Hyderabad
SHRI S. A. REDDI DR N. V. NAYAK (<i>Alternate</i>)	Gammon India Ltd, Mumbai
SHRI S. C. SAWHNEY SHRI R. P. MEHROTRA (<i>Alternate</i>)	Engineers India Ltd, New Delhi
SHRI J. R. SHARMA SHRI SURINDER MOHAN (<i>Alternate</i>)	Army Headquarters, Engineer-in-Chief's Branch, New Delhi
PROF M. S. SHETTY	Indian Concrete Institute, Chennai
SHRI B. T. UNWALLA	In personal capacity (<i>15/9, Rustam Baug, Victoria Road, Mumbai</i>)
DIRECTOR (C&MDD) DEPUTY DIRECTOR (C&MDD) (<i>Alternate</i>)	Central Water Commission, New Delhi

Bureau of Indian Standards

BIS is a statutory institution established under the *Bureau of Indian Standards Act, 1986* to promote harmonious development of the activities of standardization, marking and quality certification of goods and attending to connected matters in the country.

Copyright

BIS has the copyright of all its publications. No part of these publications may be reproduced in any form without the prior permission in writing of BIS. This does not preclude the free use, in the course of implementing the standard, of necessary details, such as symbols and sizes, type or grade designations. Enquiries relating to copyright be addressed to the Director (Publications), BIS.

Review of Indian Standards

Amendments are issued to standards as the need arises on the basis of comments. Standards are also reviewed periodically; a standard along with amendments is reaffirmed when such review indicates that no changes are needed; if the review indicates that changes are needed, it is taken up for revision. Users of Indian Standards should ascertain that they are in possession of the latest amendments or edition by referring to the latest issue of 'BIS Handbook' and 'Standards : Monthly Additions'.

This Indian Standard has been developed from Doc : No. CED 2 (3196).

Amendments Issued Since Publication

Amend No.	Date of Issue	Text Affected

BUREAU OF INDIAN STANDARDS

Headquarters:

Manak Bhavan, 9 Bahadur Shah Zafar Marg, New Delhi 110002
Telephones : 323 01 31, 323 94 02, 323 33 75

Telegrams: Manaksanstha
(Common to
all offices)

Regional Offices:

Central : Manak Bhavan, 9 Bahadur Shah Zafar Marg
NEW DELHI 110002

Telephone

{ 323 76 17
323 38 41

Eastern : 1/14 C. I. T. Scheme VII M, V. I. P. Road, Maniktola
CALCUTTA 700054

{ 337 84 99, 337 85 61
337 86 26, 337 86 62

Northern : SCO 335-336, Sector 34-A, CHANDIGARH 160022

{ 60 38 43
60 20 25

Southern : C. I. T. Campus, IV Cross Road, CHENNAI 600113

{ 235 02 16, 235 04 42
235 15 19, 235 23 15

Western : Manakalaya, E9 MIDC, Marol, Andheri (East)
MUMBAI 400093

{ 832 92 95, 832 78 58
832 78 91, 832 78 92

Branches : AHMADABAD. BANGALORE. BHOPAL. BHUBANESHWAR.
COIMBATORE. FARIDABAD. GHAZIABAD. GUWAHATI. HYDERABAD. JAIPUR.
KANPUR. LUCKNOW. NAGPUR. PATNA. PUNE. THIRUVANANTHAPURAM.