

IS 13935 : 1993
(Reaffirmed 1998)
Edition 1.1
(2002-04)

भारतीय मानक

भवनों की मरम्मत तथा भूकंपीय दृष्टि से दृढीकरण —
रीति संहिता

Indian Standard

**REPAIR AND SEISMIC STRENGTHENING
OF BUILDINGS — GUIDELINES**

(Incorporating Amendment No. 1)

UDC 699.841 : 624.012.45 : 624.042.7

© BIS 2002

BUREAU OF INDIAN STANDARDS
MANAK BHAVAN, 9 BAHADUR SHAH ZAFAR MARG
NEW DELHI 110002

Price Group 9

FOREWORD

This Indian Standard was adopted by the Bureau of Indian Standards, after the draft finalized by the Earthquake Engineering Sectional Committee had been approved by the Civil Engineering Division Council.

Himalayan-Naga Lushai region, Indo-Gangetic Plain, Western India and Kutch and Kathiawar regions are geologically unstable parts of the country and some devastating earthquakes of the world have occurred there. A major part of the peninsular India, has also been visited by moderate earthquakes, but these were relatively few in number and had considerably lesser intensity. It has been a long felt need to rationalize the earthquake resistant design and construction of structures taking into account seismic data from studies of the Indian earthquakes, particularly in view of the heavy construction programme at present all over the country. It is to serve this purpose that IS 1893 : 1984 'Criteria for earthquake resistant design of structures' was prepared. It lays down the seismic zones, the basic seismic coefficients and other factors and criteria for various structures. As an adjunct to IS 1893, IS 4326 'Code of practice for earthquake resistant design and construction of buildings' was prepared in 1967 and revised in 1976 and in 1993. 1976 version, contained some recommendations for low strength brick masonry and stone buildings which have now been covered in greater detail in IS 13828 : 1993 'Guidelines for improving earthquake resistance of low strength masonry building'.

Earthquake damages to buildings in Himachal Pradesh, North Bihar and hill districts of Uttar Pradesh emphasized the need to formulate this standard to cover guidelines for repair and strengthening of these buildings from any future earthquakes.

The composition of the technical committee responsible for formulating this standard is given in Annex A.

This edition 1.1 incorporates Amendment No. 1 (April 2002). Side bar indicates modification of the text as the result of incorporation of the amendment.

Indian Standard

REPAIR AND SEISMIC STRENGTHENING OF BUILDINGS — GUIDELINES

1 SCOPE

1.1 This standard covers the selection of materials and techniques to be used for repair and seismic strengthening of damaged buildings during earthquakes and retrofitting for upgrading of seismic resistance of existing buildings.

1.2 The repair materials and techniques described herein may be used for all types of masonry and wooden buildings, and the concrete elements used in buildings.

1.3 The provisions of this standard are applicable for buildings in seismic Zones III to V of IS 1893 : 1984 which are based on damaging seismic intensities VII and more on Modified Mercalli or M.S.K. scales. The scheme of strengthening should satisfy the requirements stipulated for the seismic zone of IS 1893 : 1984, building categories of IS 4326 : 1993 and provisions made in IS 13827 : 1993 for earthen buildings and IS 13828 : 1993 for low strength masonry building. No special seismic resistance features are considered necessary for buildings in seismic Zone II.

2 REFERENCES

The Indian Standards listed below are the necessary adjuncts to this standard:

<i>IS No.</i>	<i>Title</i>
456 : 1978	Code of practice for plain and reinforced concrete
1893 : 1984	Criteria for earthquake design of structures
4326 : 1993	Code of practice for earthquake resistant design and construction of buildings (<i>third revision</i>)
13827 : 1993	Guidelines for improving earthquake resistance earthen buildings
13828 : 1993	Guidelines for improving earthquake resistance of low strength masonry buildings

3 TERMINOLOGY

3.0 For the purpose of this guide, the following definitions shall apply.

3.1 Separation Section

A gap of specified width between adjacent buildings or parts of the same building, to permit movement, in order to avoid hammering due to earthquake.

3.2 Crumple Section

A separation section filled with appropriate material which can crumple or fracture in an earthquake.

3.3 Centre of Rigidity

The point in a structure, where a lateral force shall be applied to produce equal deflections of its components, at any one level in any particular direction.

3.4 Shear Wall

A wall designed to resist lateral force in its own plane. Braced frames, subjected primarily to axial stresses, shall be considered as shear walls for the purpose of this definition.

3.5 Space Frame

A three-dimensional structural system composed of interconnected members without shear or bearing walls, so as to function as a complete self-contained unit, with or without the aid of horizontal diaphragms or floor bracing systems.

3.6 Moment Resistant Frame

A space frame capable of carrying all vertical and horizontal loads by developing bending moments in the members and at joints.

3.7 Moment Resistant Frame with Shear Walls

A space frame with moment resistant joints used in combination with shear walls to resist the horizontal loads.

3.8 Box System

A bearing wall structure without a space frame, the horizontal forces being resisted by the walls acting as shear walls.

3.9 Band

A reinforced concrete, reinforced brick or wooden runner provided horizontally in the walls to tie them together and to impart horizontal bending strength in them.

3.10 Seismic Zone, and Seismic Coefficient

The seismic Zones II to V as classified and the corresponding zone factors as specified in 6.4.2 (Table 2) of IS 1893 (Part 1).

3.11 Zone Factor (Z)

It is a factor to obtain the design spectrum depending on the perceived maximum seismic risk characterized by maximum considered earthquake (MCE) in the zone in which the structure is located.

3.12 Concrete Grades

28 days crushing strength of concrete cubes of 150 mm side, in MPa, for example, for M15 grade of concrete (*see* IS 456 : 1978), the strength = 15 MPa.

4 GENERAL PRINCIPLES AND CONCEPTS

4.1 Non-structural/Architectural Repairs

4.1.1 The buildings affected by earthquake may suffer both non-structural and structural damages. Non-structural repairs may cover the damages to civil and electrical items including the services in the building. Repairs to non-structural components need to be taken up after the structural repairs are carried out. Care should be taken about the connection details of architectural components to the main structural components to ensure their stability.

4.1.2 Non-structural and architectural components get easily affected/dislocated during the earthquake. These repairs involve one or more of the following:

- a) Patching up of defects such as cracks and fall of plaster;
- b) Repairing doors, windows, replacement of glass panes;
- c) Checking and repairing electric conduits/wiring;
- d) Checking and repairing gas pipes, water pipes and plumbing services;
- e) Re-building non-structural walls, smoke chimneys, parapet walls, etc;
- f) Replastering of walls as required;
- g) Rearranging disturbed roofing tiles;
- h) Relaying cracked flooring at ground level; and
- j) Redecoration — white washing, painting, etc.

The architectural repairs as stated above do not restore the original structural strength of structural components in the building and any attempt to carry out only repairs to architectural/non-structural elements

neglecting the required structural repairs may have serious implications on the safety of the building. The damage would be more severe in the event of the building being shaken by the similar shock because original energy absorption capacity of the building would have been reduced.

4.2 Structural Repairs

4.2.1 Prior to taking up of the structural repairs and strengthening measures, it is necessary to conduct detailed damage assessment to determine:

- a) the structural condition of the building to decide whether a structure is amenable for repair; whether continued occupation is permitted; to decide the structure as a whole or a part require demolition, if considered dangerous;
- b) if the structure is considered amenable for repair then detailed damage assessment of the individual structural components (mapping of the crack pattern, distress location; crushed concrete, reinforcement bending/yielding, etc). Non-destructive testing techniques could be employed to determine the residual strength of the members; and
- c) to work out the details of temporary supporting arrangement of the distressed members so that they do not undergo further distress due to gravity loads.

4.2.2 After the assessment of the damage of individual structural elements, appropriate repair methods are to be carried out componentwise depending upon the extent of damage. The repair may consist of the following:

- a) Removal of portions of cracked masonry walls and piers and rebuilding them in richer mortar. Use of non-shrinking mortar will be preferable.
- b) Addition of reinforcing mesh on both faces of the cracked wall, holding it to the wall through spikes or bolts and then covering it, suitably, with cement mortar or micro-concrete.
- c) Injecting cement or epoxy like material which is strong in tension, into the cracks in walls.
- d) The cracked reinforced cement elements may be repaired by epoxy grouting and could be strengthened by epoxy or polymer mortar application like shotcreting, jacketing, etc.

4.3 Seismic Strengthening

The main purpose of the seismic strengthening is to upgrade the seismic resistance of a damaged building while repairing so that it becomes safer under future earthquake occurrences. This work may involve some of the following actions:

- a) Increasing the lateral strength in one or both directions by increasing column and wall areas or the number of walls and columns.
- b) Giving unity to the structure, by providing a proper connection between its resisting elements, in such a way that inertia forces generated by the vibration of the building can be transmitted to the members that have the ability to resist them. Typical important aspects are the connections between roofs or floors and walls, between intersecting walls and between walls and foundations.
- c) Eliminating features that are sources of weakness or that produce concentration of stresses in some members. Asymmetrical plan distribution of resisting members, abrupt changes of stiffness from one floor to the other, concentration of large masses and large openings in walls without a proper peripheral reinforcement are examples of defects of this kind.
- d) Avoiding the possibility of brittle modes of failure by proper reinforcement and connection of resisting members.

4.4 Seismic Retrofitting

Many existing buildings do not meet the seismic strength requirements of present earthquake codes due to original structural inadequacies and material degradation due to time or alterations carried out during use over the years. Their earthquake resistance can be upgraded to the level of the present day codes by appropriate seismic retrofitting techniques, such as mentioned in 4.3.

4.5 Strengthening or Retrofitting vs. Reconstruction

4.5.1 Replacement of damaged buildings or existing unsafe buildings by reconstruction is, generally, avoided due to a number of reasons, the main ones among them being:

- a) higher cost than that of strengthening or retrofitting,
- b) preservation of historical architecture, and
- c) maintaining functional social and cultural environment.

In most instances, however, the relative cost of retrofitting to reconstruction cost determines the decision. As a thumb rule, if the cost of repair and seismic strengthening is less than about 50 percent of the reconstruction cost, the retrofitting is adopted. This may also require less working time and much less dislocation in the living style of the population. On the other hand reconstruction may offer the possibility of modernization of the habitat and may be preferred by well-to-do communities.

4.5.2 Cost wise the building construction including the seismic code provisions in the first instance, works out the cheaper in terms of its own safety and that of the occupants. Retrofitting an existing inadequate building may involve as much as 4 to 5 times the initial extra expenditure required on seismic resisting features. Repair and seismic strengthening of a damaged building may even be 5 to 10 times as expensive. It is therefore very much safer as well as cost-effective to construct earthquake resistant buildings at the initial stage itself according to the relevant seismic IS codes.

5 SELECTION OF MATERIALS AND TECHNIQUES

5.1 General

The most common materials for repair works of various types buildings are cement and steel. In many situations suitable admixture may be added to cement mortar/cement concrete to improve their properties, such as, non-shrink-age, bond, etc. Steel may be required in many forms like bolts, rods, angles, beams, channels, expanded metal and welded wire fabric. Wood and bamboo are the most common material for providing temporary supports and scaffolding, etc, and will be required in the form of rounds, sleepers, planks, etc.

Besides the above, special materials and techniques are available for best results in the repair and strengthening operations. These should be selected appropriately depending on the nature and cost of the building that is to be repaired, materials availability and feasibility and use of available skills, etc. Some special materials and techniques are described below.

5.2 Shotcrete

Shotcrete is cement mortar or cement concrete (with coarse aggregate size maximum 10 mm) conveyed through a hose and pneumatically placed under high velocity on to a prepared concrete or masonry surface. The force of the jet impingement on the surface compacts the shotcrete material and produces a dense homogeneous mass. Basically there are two

methods of shotcreting; wet mix process and dry mix process. In the wet mix process, all the ingredients including water are mixed together before they enter the delivery hose. In the dry mix process, the mixture of damp sand and cement is passed through the delivery hose to the nozzle where the water is added. The dry mix process is generally used in the repair of concrete elements. The bond between the prepared concrete surface of the damaged member and the layer of shotcrete is ensured with the application of suitable epoxy adhesive formulation. The shear transfer between the existing and new layer of concrete is ensured with the provision of shear keys.

5.3 Epoxy Resins

Epoxy resins are excellent binding agents with high tensile strength. These are chemical preparations the compositions of which can be changed as per requirements. The epoxy components are mixed just prior to application. Some products are of low viscosity and can be injected in fine cracks too. The higher viscosity epoxy resin can be used for surface coating or filling larger cracks or holes. The epoxy resins may also be used for gluing steel plates to the distress members.

5.4 Epoxy Mortar

For larger void spaces, it is possible to combine the epoxy resins of either low viscosity or higher viscosity with sand aggregate to form epoxy mortar. Epoxy mortar mixture has higher compressive strength, higher tensile strength and a lower modulus of elasticity than cement concrete. The sand aggregate mixed to form the epoxy mortar increases its modulus of elasticity.

5.5 Quick-Setting Cement Mortar

This material is a non-hydrous magnesium phosphate cement with two components, that is, a liquid and a dry powder, which can be mixed in a manner similar to cement concrete.

5.6 Mechanical Anchors

Mechanical type of anchors employ wedging action to provide anchorage. Some of the anchors provide both shear and tension resistance. Such anchors are manufactured to give sufficient strength.

Alternatively, chemical anchors bonded in drilled holes through polymer adhesives can be used.

6 TECHNIQUES TO RESTORE ORIGINAL STRENGTH

6.1 General

While considering restoration of structural strength, it is important to realise that even

fine cracks in load bearing members which are unreinforced like masonry and plain concrete reduce their resistance very largely. Therefore, all cracks must be located and marked carefully and the critical ones fully repaired either by injecting strong cement or chemical grout or by providing external bandage. The techniques are described below along with other restoration measures.

6.2 Repair of Minor and Medium Cracks

For the repair of minor and medium cracks (0.50 mm to 5 mm), the technique to restore the original tensile strength of the cracked element is by pressure injection of epoxy. The procedure is as follows (*see* Fig. 1A):

'The external surfaces are cleaned of non-structural materials and plastic injection ports are placed along the surface of the cracks on both sides of the member and are secured in place with an epoxy sealant. The centre-to-centre spacing of these ports may be approximately equal to the thickness of the element. After the sealant has cured, a low viscosity epoxy resin is injected into one port at a time beginning at the lowest part of the crack, in case it is vertical, or at one end of the crack, in case it is horizontal.

The resin is injected till it is seen flowing from the opposite sides of the member at the corresponding port or from the next higher port on the same side of member. The injection port should be closed at this stage and injection equipment moved to the next port and so on.

The smaller the crack higher is the pressure or more closely spaced should be the ports so as to obtain complete penetration of the epoxy material throughout the depth and width of member. Larger cracks will permit larger port spacing depending upon width of the member. This technique is appropriate for all types of structural elements — beams, columns, walls and floor units in masonry as well as concrete structures. In the case of loss of bond between reinforcing bar and concrete, if the concrete adjacent to the bar has been pulverised to a very fine powder (this powder will block the epoxy from penetrating the region). It should be cleaned properly by air or water pressure prior to injection of epoxy.'

6.3 Repair of Major Cracks and Crushed Concrete

For cracks wider than about 5 mm or for regions in which the concrete or masonry has crushed, a treatment other than injection is indicated.

The procedures may be adopted as follows:

- a) The loose material is removed and replaced with any of the materials mentioned earlier, that is, expansive cement mortar quick setting cement (see Fig. 1B).
- b) Where found necessary, additional shear or flexural reinforcement is provided in the region of repairs. This reinforcement could be covered by mortar to give further strength as well as protection to the reinforcement (see Fig. 1C).
- c) In areas of very severe damage, replacement of the member or portion of member can be carried out as discussed later.
- d) In the case of damage to walls and floor diaphragms, steel mesh could be provided on the outside of the surface and nailed or bolted to the wall. Then it may be covered with plaster or micro-concrete (see Fig. 1C).

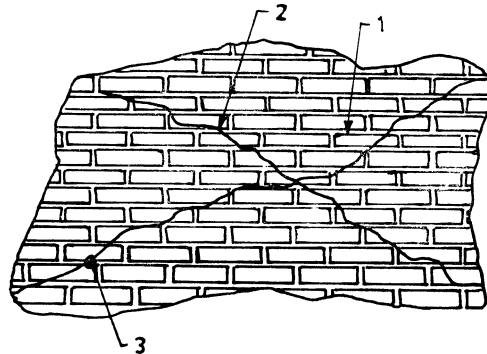

1A Grout or epoxy injection in cracks

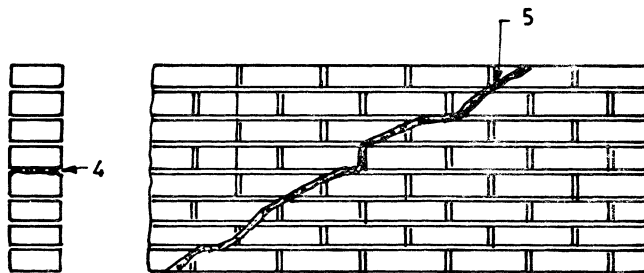

1B Cement mortar and flat chips in wide cracks

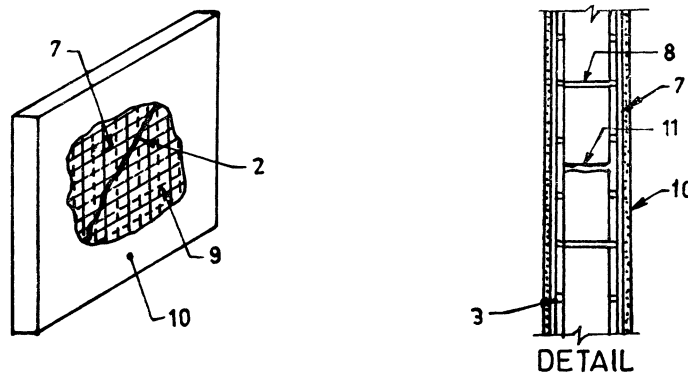

1C Cement mortar and wire mesh in cracks

- | | |
|---------------------------------------|----------------------------|
| 1. Plaster removed | 7. Wire-mesh on front face |
| 2. Cracks sealed after cleaning | 8. Clamps |
| 3. Grout ports | 9. Wire-mesh on back face |
| 4. V-groove joints | 10. Cement plaster |
| 5. Cement mortar and flat stone chips | 11. Crack in wall |

FIG. 1 STRUCTURAL RESTORATION OF CRACKED MASONRY WALLS

6.4 Fractured Excessively Yielded and Buckled Reinforcement

In the case of severely damaged reinforced concrete member it is possible that the reinforcement would have buckled or elongated or excessive yielding may have occurred. This element can be repaired by replacing the old portion of steel with new steel using butt welding or lap welding.

Splicing by overlapping will be risky. If repair has to be made without removal of the existing steel, the best approach would depend upon the space available in the original member. Additional stirrup ties are to be added in the damaged portion before concreting so as to confine the concrete and enclose the longitudinal bars to prevent their buckling in future.

In some cases, it may be necessary to anchor additional steel into existing concrete. A common technique for providing the anchorage uses the following procedure:

‘A hole larger than the bar is drilled. The hole is filled with epoxy expanding cement or other high strength grouting material. The bar is pushed into place and held there until the grout has set.’

6.5 Fractured Wooden Members and Joints

Since wood is an easily workable material, it will be easy to restore the strength of wooden members such as beams, columns, struts, and ties by splicing additional material. The weathered or rotten wood should first be removed. Nails wood screws or steel bolts will be most convenient as connectors. It will be advisable to use steel straps to cover all such splices and joints so as to keep them tight and stiff.

7 SEISMIC STRENGTHENING TECHNIQUES

7.1 Modification of Roofs or Floors

7.1.1 Slates and roofing tiles are brittle and easily dislodged. Where possible, they should be replaced with corrugated iron or asbestos sheeting.

7.1.2 False ceilings of brittle material are dangerous. Non-brittle material, like hessian cloth, bamboo matting or light ones of foam substances, may be substituted.

7.1.3 Roof truss frames should be braced by welding or clamping suitable diagonal bracing members in the vertical as well as horizontal planes.

7.1.4 Anchors of roof trusses to supporting walls should be improved and the roof thrust on walls should be eliminated.

Figures 2 and 3 illustrate one of the methods for pitched roofs without trusses.

7.1.5 Where the roof or floor consists of prefabricated units like RC rectangular T or channel units or wooden poles and joists carrying brick tiles, integration of such units is necessary. Timber elements could be connected to diagonal planks nailed to them and spiked to an all round wooden frame at the ends. Reinforced concrete elements may either have 40 mm cast-in-situ-concrete topping with 6 mm dia bars 150 mm c/c both ways or bounded by a horizontal cast-in-situ-reinforced concrete ring beam all round into which the ends of reinforced concrete elements are embedded. Fig. 4 shows one such detail.

7.1.6 Roofs or floors consisting of steel joists flat or segmental arches must have horizontal ties holding the joists horizontally in each arch span so as to prevent the spreading of joists. If such ties do not exist, these should be installed by welding or clamping.

7.2 Inserting New Walls

7.2.1 Unsymmetrical buildings which may produce dangerous torsional effects during earthquakes the center of masses can be made coincident with the centre of stiffnesses by separating parts of buildings thus achieving individual symmetric units and/or inserting new vertical resisting elements such as new masonry or reinforced concrete walls either internally as shear walls or externally as buttresses. Insertion of cross wall will be necessary for providing transverse supports to longitudinal walls of long barrack-type buildings used for various purposes such as schools and dormitories.

7.2.2 The main problem in such modifications is the connection of new walls with old walls. Figures 5, 6 and 7 show three examples of connection of new walls to existing ones. The first two cases refer to a T-junction whereas the third to a corner junction. In all cases the link to the old walls is performed by means of a number of keys made in the old walls. Steel is inserted in them and local concrete infilling is made. In the second case, however, connection can be achieved by a number of steel bars inserted in small length drilled holes filled with fresh cement-grout which substitute keys.

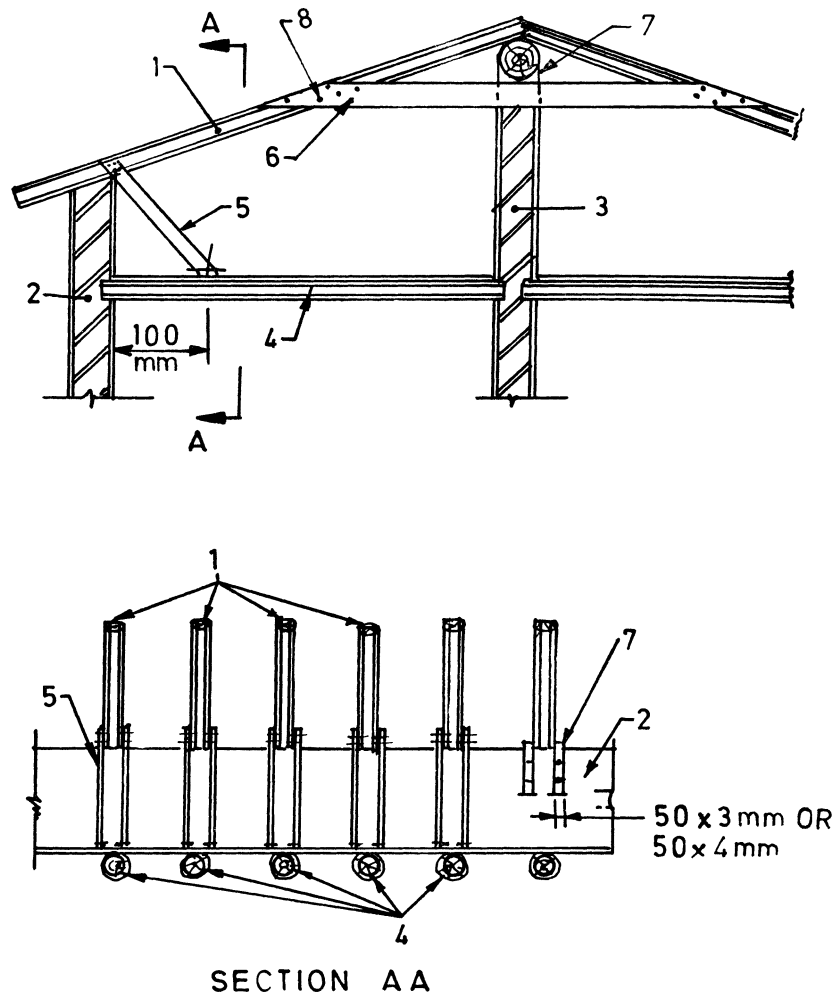

1. Existing rafters
2. Existing outer wall
3. Existing inner wall
4. Existing floor beam
5. New planks 200×40 mm nailed at ends
6. New planks 200×40 mm nailed at ends to take rafter thrust
7. U-steel anchor clamp bolted to existing wall at 3 to 4 m apart
8. Nails

FIG. 2 ROOF MODIFICATION TO REDUCE THRUST OF WALLS

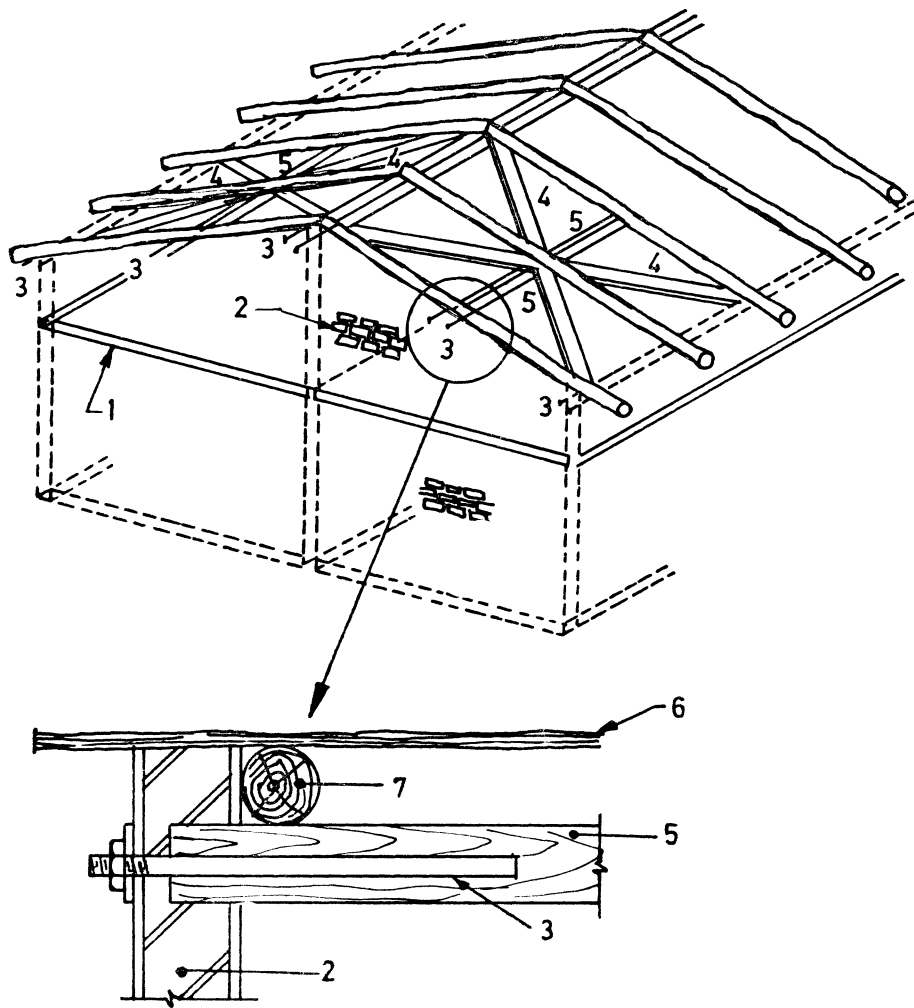

1. Existing floor
2. Existing gable wall (tympanum)
3. Steel strips bolted to new ties (5) and wall (2)
4. New planks diagonal bracing
5. New planks, ties
6. Roof covering
7. Existing roof rafters

FIG. 3 DETAILS OF NEW ROOF BRACING

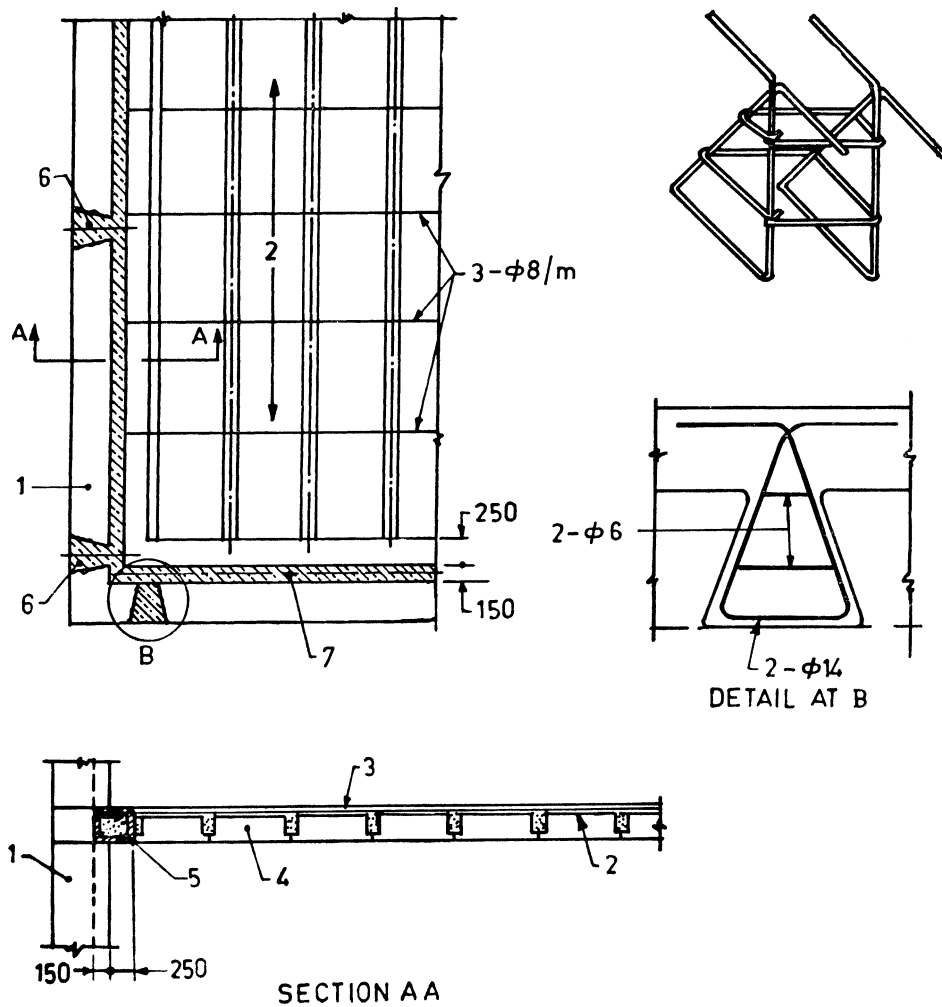

- SECTION A A
1. Existing wall
 2. Existing or new prefabrication floor
 3. Slab topping with reinforcement
 4. Prefab slab units
 5. R. C. band
 6. Keys connecting new floor to existing wall @ 3 m
 7. Grooves cut in wall

All dimensions in millimetres.

FIG. 4 INTEGRATION AND STIFFENING OF AN EXISTING FLOOR

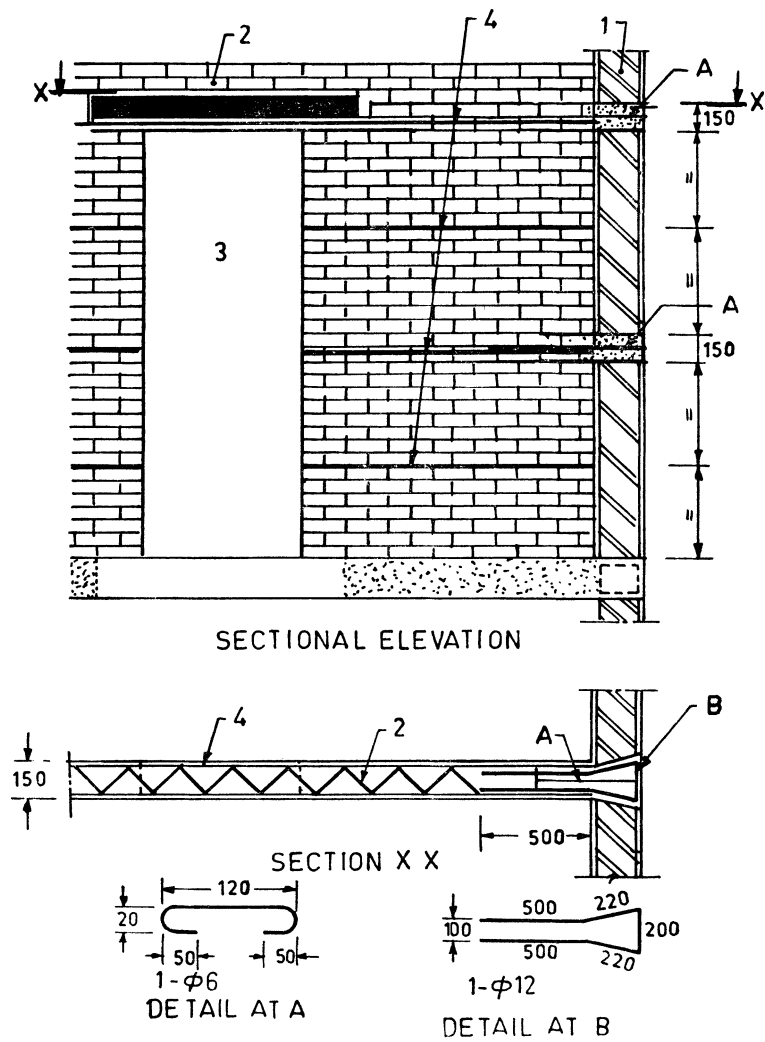

1. Existing wall
2. New wall
3. Door opening
4. Horizontal reinforcement (examples of truss system shown)

All dimensions in millimetres.

FIG. 5 CONNECTION OF NEW AND OLD BRICK WALLS (T-JUNCTION)

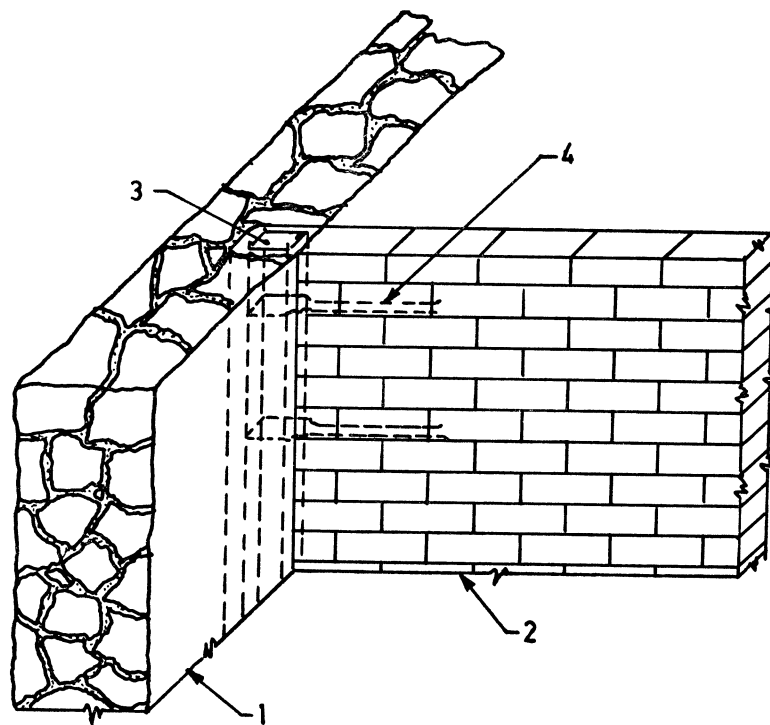

1. Existing old wall
2. New wall
3. Concrete-column for bonding
4. Connecting ties of steel, every fourth course

FIG. 6 CONNECTION OF NEW BRICK WALL WITH EXISTING STONE WALL

7.3 Strengthening Existing Walls

7.3.0 The lateral strength of buildings can be improved by increasing the strength and stiffness of existing individual walls, whether they are cracked or uncracked, can be achieved.

- a) by grouting,
- b) by addition of vertical reinforced concrete coverings on the two sides of the wall, and
- c) by prestressing wall.

7.3.1 Grouting

A number of holes are drilled in the wall (2 to 4 in each square metre) (see Fig. 8). First water is injected in order to wash the wall inside, and

to improve the cohesion between the grouting mixture and the wall elements. Secondly, a cement water mixture (1 : 1) is grouted at low pressure (0.1 to 0.25 MPa) in the holes starting from the lower holes and going up.

Alternatively, polymeric mortars may be used for grouting. The increase of shear strength which can be achieved in this way is considerable. However, grouting can not be relied on as far as the improving or making a new connection between orthogonal walls is concerned.

NOTE — The pressure need for grouting can be obtained by gravity flow from superelevated containers.

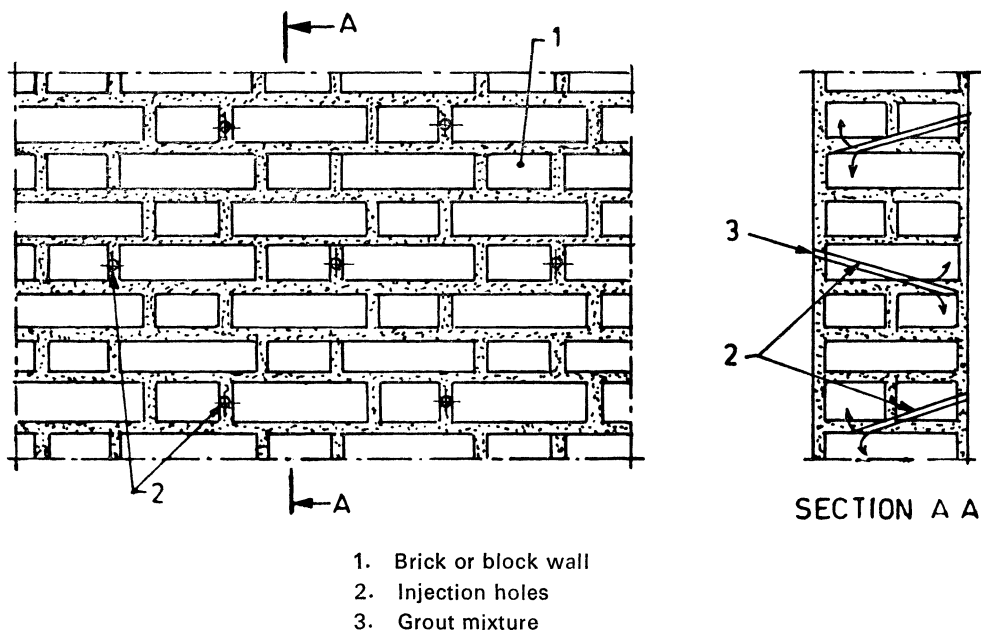

FIG. 8 GROUT OR EPOXY INJECTION IN EXISTING WEAK WALLS

7.3.2 Strengthening with Wire Mesh

Masonry walls with concentration of multiple cracks in the same portion and appearing on both sides on the wall or weak wall regions may be repaired with a layer of cement mortar or micro concrete layer 20 to 40 mm thick on both

sides, reinforced with galvanized steel wire fabric (50 mm × 50 mm size) forming a vertical plate bonded to the wall. The two plates on either side of the wall should be connected by galvanized steel rods at a spacing of about 300 to 400 mm (see Fig 9).

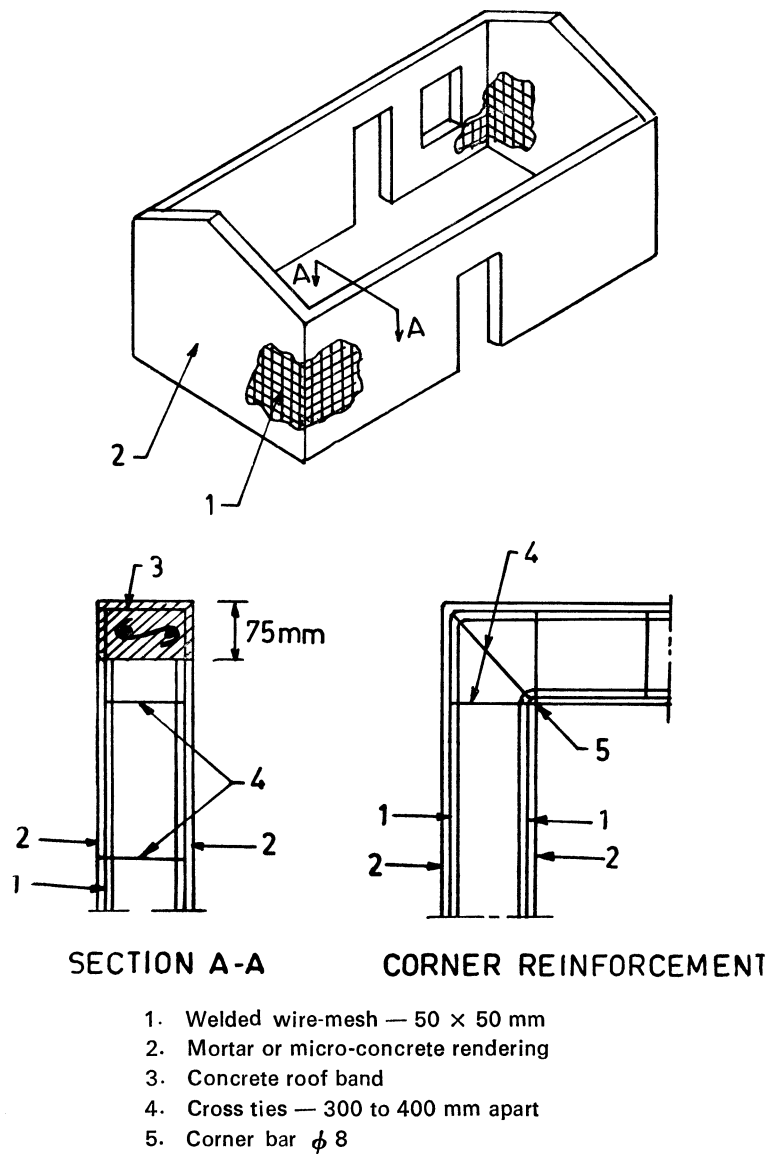
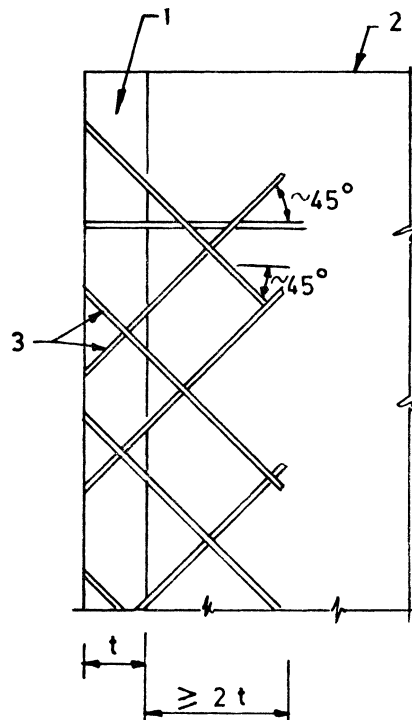

FIG. 9 STRENGTHENING WITH WIRE-MESH AND MORTAR

7.3.3 Connection Between Existing Stone Walls

In stone buildings of historic importance, consisting of fully dressed stone masonry in good mortar, effective sewing of perpendicular

walls may be done by drilling inclined holes through them inserting steel rods and injecting cement grout (see Fig. 10).



1. Transverse wall
2. Longitudinal wall
3. ϕ 10 bars in 20 mm dia holes filled with cement grout

FIG. 10 SEWING TRANSVERSE WALLS WITH INCLINED BARS

7.4 Achieving Integral Box Action

7.4.0 The overall lateral strength and stability of bearing wall buildings is very much improved, if the integral box like action of room enclosures is ensured. This can be achieved by (a) use of prestressing (b) providing horizontal bands. Strength of shear walls is achieved by providing vertical steel at selected locations as described in 7.4.1 and 7.4.2.

7.4.1 Prestressing

A horizontal compression state induced by horizontal tendons can be used to increase the shear strength of walls. Moreover, this will also improve, considerably, the connections of orthogonal walls (see Fig. 11). The easiest way of affecting the precompression is to place two steel rods on the two sides of the wall and stretching them by turnbuckles. Note that, good effects can be obtained by slight horizontal prestressing (about 0.1 MPa) on the vertical section of the wall. Prestressing is also useful to

strengthen spandrel beam between two rows of openings in the case no rigid slab exists.

Opposite parallel walls can be held to internal cross walls by prestressing bars as illustrated above the anchoring being done against horizontal steel channels instead of small steel plates. The steel channels running from one cross wall to the other will hold the walls together and improve the integral box like action of the walls.

7.4.2 External Binding

The technique of covering the wall with steel mesh and mortar or microconcrete may be used only on the outside surface of external walls but maintaining continuity of steel at the corners. This would strengthen the walls as well as bind them together. As a variation and for economy in the use of materials, the covering may be in the form of vertical splints located between the openings and horizontal 'bandages' formed over spandrel walls at suitable number of points only (see Fig. 12).

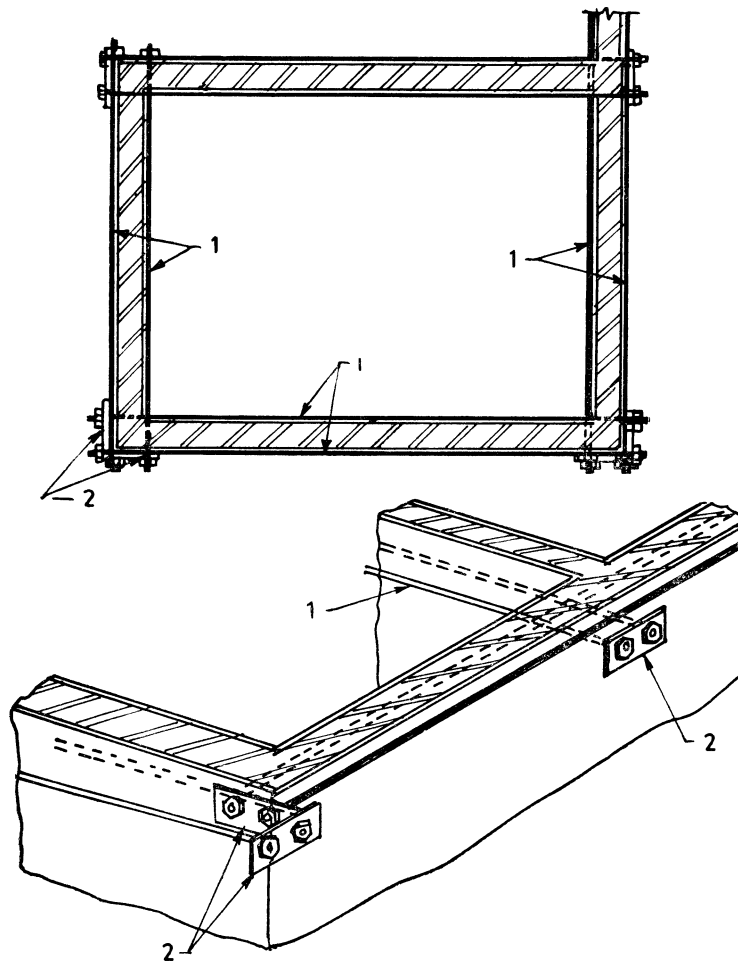

1. Steel rods for prestressing 2. Anchor plates

FIG. 11 STRENGTHENING OF WALLS BY PRESTRESSING

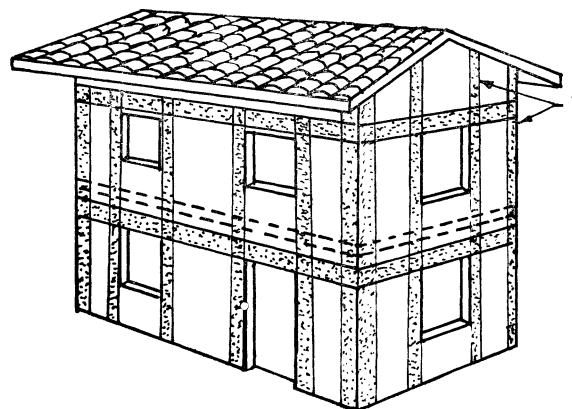

1. WIRE MESH WITH WIDTH \geq 400 mm

FIG. 12 SPLINT AND BANDAGE STRENGTHENING TECHNIQUE

7.5 Masonry Arches

If the walls have large arched openings in them, it will be necessary to install tie rods across them at springing levels or slightly above it by drilling holes on both sides and grouting steel rods in them (see Fig. 13a). Alternatively, a lintel consisting of steel

channels or I-shapes could be inserted just above the arch to take the load and relieve the arch as shown at Fig. 13b. In jack-arch roofs, flat iron bars or rods shall be provided to connect the bottom flanges of I-beams connected by bolting or welding (see Fig. 13c).

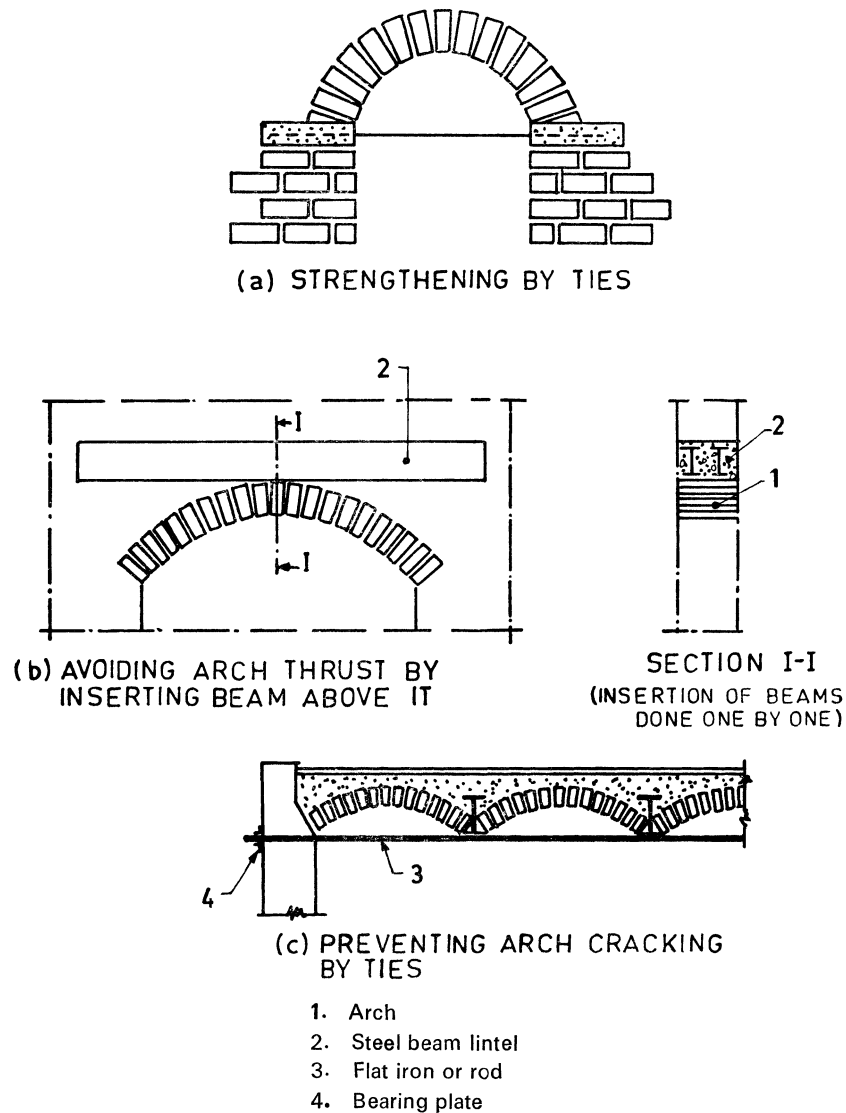

FIG. 13 STRENGTHENING AN ARCHED OPENING IN MASONRY WALL

7.6 Random Rubble Masonry Walls

Random rubble masonry walls are most vulnerable to delamination and complete collapse and must be strengthened by internal impregnation by rich cement mortar grout in the ratio of 1 : 1 as explained in 7.3.1 or covered with steel mesh and mortar as in 7.3.2.

Damaged portions of the wall, if any should be reconstructed using richer mortar. In thick walls, 'through' stones or bonding elements shall be installed, if not present originally, at each one-third point along the length and height of wall (see Fig. 14).

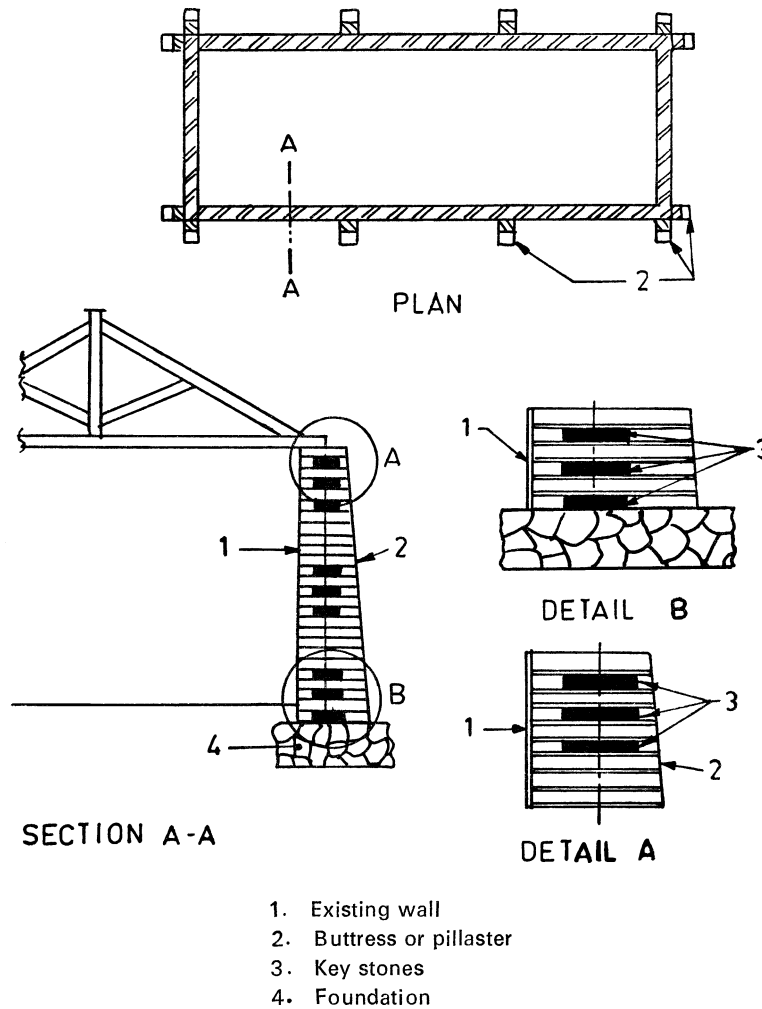

FIG. 14 STRENGTHENING OF LONG WALLS BY BUTTRESSES

7.7 Strengthening Long Walls

For bracing the longitudinal walls of long barrack type buildings a portal type framework may be inserted transverse to the walls and connected to them. Alternatively masonry buttresses or pillasters may be added externally as shown in Fig. 14.

7.8 Strengthening Reinforced Concrete Members

7.8.1 Columns

Reinforced concrete columns can best be strengthened by casing, that is, by providing additional cage of longitudinal and lateral tie reinforcement around the columns and casting a concrete ring (see Fig. 15). The desired strength and ductility can thus be built-up.

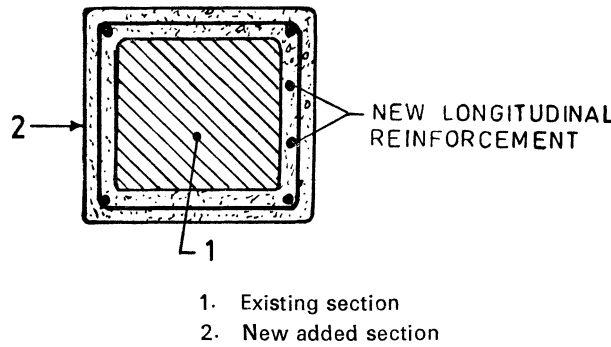

FIG. 15 CASING A CONCRETE COLUMN

7.8.2 Beams

A reinforced concrete beam can be encased as shown in Fig. 16 (A). For holding the stirr-up in this case, holes will have to be drilled through the slab. Alternatively it can be jacketed as

shown in Fig. 16 (B), and Fig. 16 (C) wherein holes will need to be drilled through web of existing beam for the new stirr-ups. Desired quantity of longitudinal and transverse steel may be added in each case.

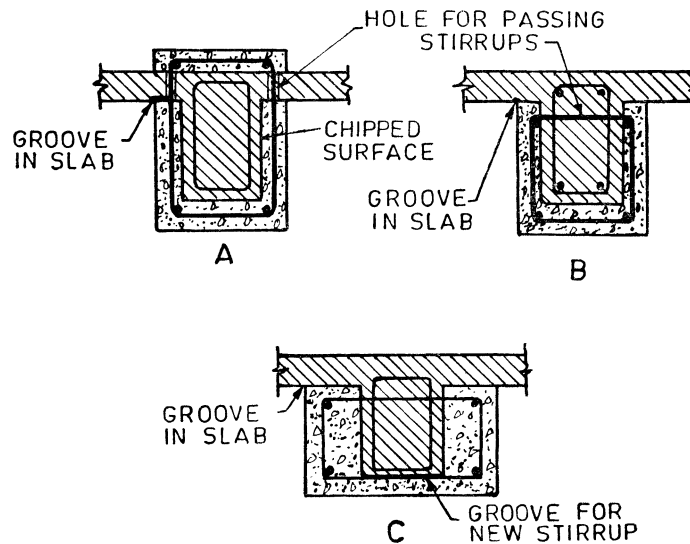

FIG. 16 INCREASING THE SECTION AND REINFORCEMENT OF EXISTING BEAMS

Reinforced concrete beams can also be strengthened by applying prestress to it so that opposite moments are caused to those applied. The wires will run on both sides of the web

outside and anchored against the end of the beam through a steel plate. Loss of prestress due to creep relation and temperature fall shall be duly considered.

7.8.3 Shear Walls

The casing technique could be used for strengthening reinforced concrete shear walls.

7.8.4 Inadequate section of beams, columns and walls could be strengthened by adding a layer of reinforced concrete (outershell) around the members with the addition of new reinforcements. Also to the existing steel, new steel reinforcement bars could be welded to increase the carrying capacity of the members.

In all cases of adding new concrete to the old concrete, effective bond should be ensured. Such bond could be created by the application of suitable epoxy adhesive formulations on the prepared old concrete surface. In addition to this, suitable shear connectors in the form of steel rods placed in predrilled holes in the old concrete at required spacing should be provided. These rods should also be dipped in epoxy adhesive formulations before placing in position.

7.8.5 In all cases of adding new concrete to old concrete the original surface should be roughened, grooves made in the appropriate direction for providing shear transfer. The ends of the additional steel are to be anchored in the adjacent beams or columns as the case may be.

7.9 Strengthening of Foundations

Strengthening of foundations before or after

the earthquake is the most involved task since it may require careful underpinning operations. Some alternatives are given below for preliminary consideration of the strengthening scheme:

- a) Introducing new load bearing members including foundations to relieve the already loaded members. Jacking operations may be needed in this process.
- b) Improving the drainage of the area to prevent saturation of foundation soil to obviate any problems of liquefaction which may occur because of poor drainage.
- c) Providing apron around the building to prevent soaking of foundation directly and draining off the water.
- d) Adding strong elements in the form of reinforced concrete strips attached to the existing foundation part of the building. These will also bind the various wall footings and may be provided on both sides of the wall (see Fig. 17) or only one side of it. In any case, the reinforced concrete strips and the wall have to be linked by a number of keys inserted into the existing footing.

NOTE — To avoid disturbance to the integrity of the existing wall during the foundation strengthening process proper investigation and design is called for.

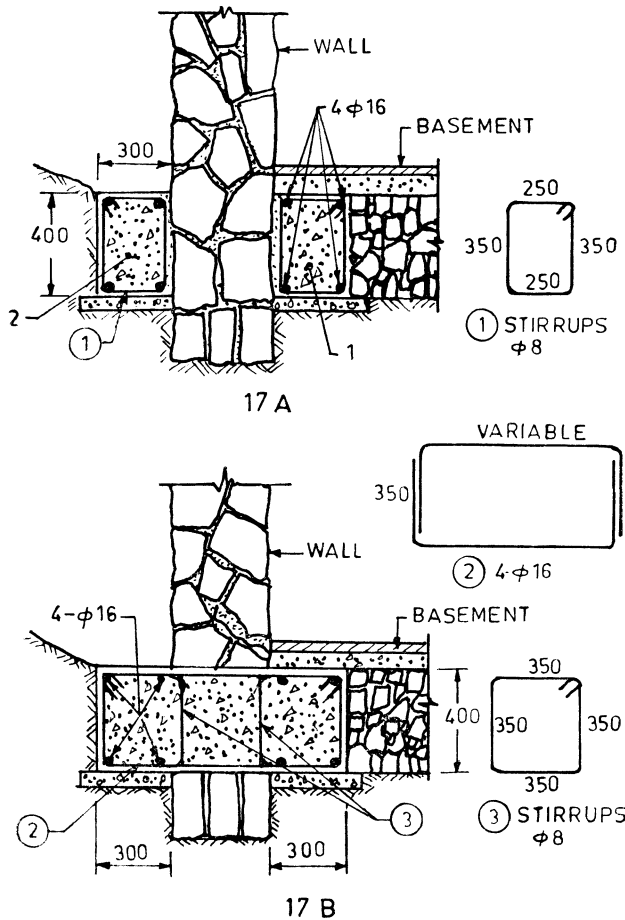

FIG. 17 STRENGTHENING EXISTING FOUNDATION (R. C. STRIP ON BOTH SIDES)

ANNEX A*(Foreword)***COMMITTEE COMPOSITION****Earthquake Engineering Sectional Committee, CED 39**

<i>Chairman</i>	<i>Representing</i>
DR A. S. ARYA	72/6 Civil Line, Roorkee
<i>Members</i>	
SHRI O. P. AGGARWAL	Indian Roads Congress, New Delhi
SHRI G. SHARAN (<i>Alternate</i>)	
DR K. G. BHATIA	Bharat Heavy Electricals Ltd, New Delhi
DR C. KAMESHWARA RAO (<i>Alternate</i>)	
SHRI A. K. SINGH (<i>Alternate</i>)	
SHRI S. C. BHATIA	National Geophysical Research Institute (CSIR), Hyderabad
DR B. K. RASTOGI (<i>Alternate</i>)	
DR A. R. CHANDRASEKARAN	Department of Earthquake Engineering, University of Roorkee, Roorkee
DR BRIJESH CHANDRA (<i>Alternate</i>)	
DR B. V. K. LAVANIA (<i>Alternate</i>)	
DR S. N. CHATTERJEE	Indian Meteorological Department, New Delhi
SHRI S. K. NAG (<i>Alternate</i>)	
SHRI K. T. CHAUBAL	North Eastern Council, Shillong
DR B. K. PAUL (<i>Alternate</i>)	
DR A. V. CHUMMAR	Indian Society of Earthquake Technology, Roorkee
DR S. K. KAUSHIK (<i>Alternate</i>)	
DIRECTOR EMBANKMENT (N & W)	Central Water Commission (ERDD), New Delhi
DIRECTOR CMDD (NW & S) (<i>Alternate</i>)	
DIRECTOR STANDARDS (B & S), RDSO	Railway Board, Ministry of Railways
JOINT DIRECTOR STANDARDS (B & S)	
CB-I, RDSO, LUCKNOW (<i>Alternate</i>)	
KUMARI E. DIVATIA	National Hydro-Electric Power Corporation Ltd, New Delhi
SHRI C. R. VENKATESHA (<i>Alternate</i>)	
SHRI I. D. GUPTA	Central Water & Power Research Station, Pune
SHRI J. G. PADALE (<i>Alternate</i>)	
SHRI V. K. KULKARNI	Department of Atomic Energy, Bombay
SHRI P. C. KOTESWARA RAO (<i>Alternate</i>)	
SHRI V. KUMAR	National Thermal Power Corporation Ltd, New Delhi
SHRI R. S. BAJAJ (<i>Alternate</i>)	
SHRI M. Z. KURIEN	Tata Consulting Engineers, Bombay
SHRI K. V. SUBRAMANIAN (<i>Alternate</i>)	
SHRI A. K. LAL	National Buildings Organization, New Delhi
SHRI T. R. BHATIA (<i>Alternate</i>)	
SHRI S. K. MITTAL	Central Building Research Institute, Roorkee
SHRI S. S. NARANG	Central Water Commission (CMDD), New Delhi
SHRI A. D. NARIAN	Ministry of Transport, Department of Surface Transport (Roads Wing), New Delhi
SHRI O. P. AGGARWAL (<i>Alternate</i>)	
SHRI P. L. NARULA	Geological Survey of India, Calcutta
SHRI A. K. SRIVASTAVA (<i>Alternate</i>)	
RESEARCH OFFICER	Irrigation Department, Govt of Maharashtra, Nasik
DR D. SENGUPTA	Engineers India Ltd, New Delhi
SHRI R. K. GROVER (<i>Alternate</i>)	
DR R. D. SHARMA	Nuclear Power Corporation, Bombay
SHRI U. S. P. VERMA (<i>Alternate</i>)	
COL R. K. SINGH	Engineer-in-Chief's Branch, Army Headquarters, New Delhi
LT-COL B. D. BHATTOPADHYAYA (<i>Alternate</i>)	
DR P. SRINIVASULU	Structural Engineering Research Centre (CSIR), Madras
DR N. LAKSHMANAN (<i>Alternate</i>)	
SUPERINTENDING ENGINEER (D)	Central Public Works Department, New Delhi
EXECUTIVE ENGINEER (D) II (<i>Alternate</i>)	
DR A. N. TANDON	In personal capacity (<i>B-7/50 Safdarjung Development Area, New Delhi</i>)
SHRI J. VENKATARAMAN, Director (Civ Engg)	Director General, BIS (<i>Ex-officio Member</i>)

*Secretary*SHRI S. S. SETHI
Director (Civ Engg), BIS*(Continued on page 22)*

IS 13935 : 1993

(Continued from page 21)

Earthquake Resistant Construction Subcommittee, CED 39 : 1

<i>Convener</i>	<i>Representing</i>
DR A. S. ARYA	(72/6 Civil Lines, Roorkee)
<i>Members</i>	
SHRI N. K. BHATTACHARYA	Engineer-in-Chief's Branch, New Delhi
SHRI B. K. CHAKRABORTY	Housing and Urban Development Corporation, New Delhi
SHRI D. P. SINGH (<i>Alternate</i>)	
SHRI D. N. GHOSAL	North Eastern Council, Shillong
DR SUDHIR K. JAIN	Indian Institute of Technology, Kanpur
DR A. S. R. SAI (<i>Alternate</i>)	
SHRI M. P. JAISINGH	Central Buildings Research Institute, Roorkee
JOINT DIRECTOR STANDARDS (B & S) CB-I	Railway Board (Ministry of Railways)
ASSISTANT DIRECTOR (B & S) CB-I (<i>Alternate</i>)	
SHRI V. KAPUR	Public Works Department, Government of Himachal Pradesh, Simla
SHRI V. K. KAPOOR (<i>Alternate</i>)	
SHRI M. KUNDU	Hindustan Prefab Limited, New Delhi
SHRI A. K. LAL	National Buildings Organization, New Delhi
SHRI T. R. BHATIA (<i>Alternate</i>)	
DR B. C. MATHUR	University of Roorkee, Department of Earthquake Engineering, Roorkee
DR (SHRIMATI) P. R. BOSE (<i>Alternate</i>)	
SHRI G. M. SHOUNTHU	Public Works Department, Jammu & Kashmir
DR P. SRINIVASULU	Structural Engineering Research Centre (CSIR), Madras
DR N. LAKSHMANAN (<i>Alternate</i>)	
SHRI SUBRATA CHAKRAVARTY	Public Works Department, Government of Assam, Gauhati
SUPERINTENDING ENGINEER (DESIGN)	Public Works Department, Government of Gujrat
SUPERINTENDING SURVEYOR OF WORKS (NDZ)	Central Public Works Department, New Delhi
SUPERINTENDING ENGINEER (D) (<i>Alternate</i>)	

Standard Mark

The use of the Standard Mark is governed by the provisions of the *Bureau of Indian Standards Act, 1986* and the Rules and Regulations made thereunder. The Standard Mark on products covered by an Indian Standard conveys the assurance that they have been produced to comply with the requirements of that standard under a well defined system of inspection, testing and quality control which is devised and supervised by BIS and operated by the producer. Standard marked products are also continuously checked by BIS for conformity to that standard as a further safeguard. Details of conditions under which a licence for the use of the Standard Mark may be granted to manufacturers or producers may be obtained from the Bureau of Indian Standards.

Bureau of Indian Standards

BIS is a statutory institution established under the *Bureau of Indian Standards Act*, 1986 to promote harmonious development of the activities of standardization, marking and quality certification of goods and attending to connected matters in the country.

Copyright

BIS has the copyright of all its publications. No part of these publications may be reproduced in any form without the prior permission in writing of BIS. This does not preclude the free use, in the course of implementing the standard, of necessary details, such as symbols and sizes, type or grade designations. Enquiries relating to copyright be addressed to the Director (Publications), BIS.

Review of Indian Standards

Amendments are issued to standards as the need arises on the basis of comments. Standards are also reviewed periodically; a standard along with amendments is reaffirmed when such review indicates that no changes are needed; if the review indicates that changes are needed, it is taken up for revision. Users of Indian Standards should ascertain that they are in possession of the latest amendments or edition by referring to the latest issue of 'BIS Catalogue' and 'Standards : Monthly Additions'.

This Indian Standard has been developed from Doc : No. CED 39 (5270)

Amendments Issued Since Publication

Amend No.	Date of Issue
Amd. No. 1	April 2002

BUREAU OF INDIAN STANDARDS

Headquarters:

Manak Bhavan, 9 Bahadur Shah Zafar Marg, New Delhi 110002.
Telephones: 323 01 31, 323 33 75, 323 94 02

Telegrams: Manaksanstha
(Common to all offices)

Regional Offices:

Central : Manak Bhavan, 9 Bahadur Shah Zafar Marg
NEW DELHI 110002

Telephone

{ 323 76 17
{ 323 38 41

Eastern : 1/14 C. I. T. Scheme VII M, V. I. P. Road, Kankurgachi
KOLKATA 700054

{ 337 84 99, 337 85 61
{ 337 86 26, 337 91 20

Northern : SCO 335-336, Sector 34-A, CHANDIGARH 160022

{ 60 38 43
{ 60 20 25

Southern : C. I. T. Campus, IV Cross Road, CHENNAI 600113

{ 235 02 16, 235 04 42
{ 235 15 19, 235 23 15

Western : Manakalaya, E9 MIDC, Marol, Andheri (East)
MUMBAI 400093

{ 832 92 95, 832 78 58
{ 832 78 91, 832 78 92

Branches : AHMEDABAD. BANGALORE. BHOPAL. BHUBANESHWAR. COIMBATORE.
FARIDABAD. GHAZIABAD. GUWAHATI. HYDERABAD. JAIPUR. KANPUR.
LUCKNOW. NAGPUR. NALAGARH. PATNA. PUNE. RAJKOT. THIRUVANANTHAPURAM.
VISHAKHAPATNAM.