

भारतीय मानक

चकोरदार सीमेंट कंकरीट टाइलें — विशिष्ट

*Indian Standard*

**CHEQUERED CEMENT CONCRETE TILES —  
SPECIFICATION**

UCD 666·972-431

© BIS 1993

**BUREAU OF INDIAN STANDARDS**  
MANAK BHAVAN, 9 BHADUR SHAH ZAFAR MARG  
NEW DELHI 110002

July 1993

Price Group 5

## FOREWORD

This Indian Standard was adopted by the Bureau of Indian Standards, after the draft finalized by the Flooring, Wall Finishing and Roofing Sectional Committee had been approved by the Civil Engineering Division Council.

Chequered cement concrete flooring tiles are used for footpaths, entrance and stair-cases of public buildings, passages of auditoriums and storage godowns, etc. Large number of cement concrete chequered tiles are being manufactured and used in our country. This standard is being formulated to provide necessary guidance to manufacturers and users of these tiles.

The size specified in the standard are the existing metric sizes which form the bulk of current production in the country. The concept of adopting dimensionally co-ordinated sizes is being excluded from this standard, however it is intended to incorporate them if the opportunity occurs during revision of the standard.

For the purpose of deciding whether the particular requirement of this standard, is complied with, the final value, observed or calculated expressing the result of a test or analysis, shall be rounded off in accordance with IS 2 : 1960 'Rules for rounding off numerical values (*revised*)'. The number of significant places retained in the rounded off value should be the same as that of the specified value in this standard.

The composition of the committee responsible for the formulation of this standard is given at Annex H.

## *Indian Standard*

# CHEQUERED CEMENT CONCRETE TILES — SPECIFICATION

### 1 SCOPE

1.1 This standard covers chequered cement concrete flooring tiles.

### 2 REFERENCES

The Indian Standards listed in Annex A are necessary adjuncts to this standard.

### 3 TERMINOLOGY

3.0 For the purpose of this standard the following definition and those given in IS 1237 : 1980 shall apply.

#### 3.1 Chequered Tiles

Chequered tiles are cement tiles or terrazzo tiles with the centre to centre distance of chequers not less than 25 mm and not more than 50 mm, the grooves in the chequers being uniform and straight with the depth of grooves not less than 3 mm.

### 4 MATERIALS

#### 4.1 Cement

Cement used in the manufacture of tiles shall be ordinary Portland cement conforming to IS 269 : 1989 or rapid hardening Portland cement conforming to IS 8041 : 1990 or white Portland cement conforming to IS 8032 : 1989 or Portland pozzolana cement conforming to IS 1489 ( Part 1 ) : 1976 and IS 1489 ( Part 2 ) : 1991.

#### 4.2 Aggregates

Aggregates used in the backing layer of tiles shall conform to the requirements of IS 383 : 1970. For the wearing layer, unless otherwise specified aggregates shall consist of marble chips or any other natural stone chips of similar characteristics and hardness, marble powder or dolomite powder or mixture of the two. Hardeners, if required may also be added.

#### 4.3 Pigments

4.3.1 Pigments, synthetic or otherwise, used for colouring tiles shall have durable colour. It shall not contain matters detrimental to concrete and

shall according to the colour required be one of the following or their combination:

<i>Pigments</i>	<i>Relevant Indian Standard</i>
a) Black or red or brown pigments	IS 44 : 1991
b) Green pigments	IS 54 : 1988
c) Blue pigments	IS 55 : 1970
	or IS 56 : 1975
	or IS 3574 ( Part 2 ) : 1966
d) White pigments	IS 411 : 1991
e) Yellow pigments	IS 50 : 1980
	or IS 3574 ( Part 1 ) : 1965

4.3.2 Colours other than mentioned above may also be used.

4.3.3 The pigments shall not contain zinc compounds organic dyes.

4.3.4 Lead pigments shall not be used unless otherwise specified by the purchaser.

### 5 MANUFACTURE

5.1 Chequered cement concrete flooring tiles shall be manufactured from a mixture of cement, natural aggregates, and colouring materials where required, by pressure process. During manufacture, the tile shall be subjected to a pressure of not less than 14 N/mm<sup>2</sup>.

5.2 The proportion of cement to aggregate in the backing of the tiles shall be not leaner than 1 : 3 by mass.

5.3 Where colouring material is used in the wearing layer, it shall not exceed 10 percent by mass of cement used in the mix.

5.4 On removal from the mould, the tiles shall be kept in moist condition continuously for such a period that would ensure their conformity to the requirements of this standard. Tiles shall be stored under cover,

## 6 DIMENSIONS

6.1 The size of chequered cement flooring tiles shall be as follows:

<i>Length</i>	<i>Breadth</i>	<i>Thickness</i>
mm	mm	mm
200	200	22
250	250	22
300	300	25

NOTE — The thickness shall be measured at two points situated approximately 50 mm from the ends on the fracture line of the tile that is tested for wet transverse strength. The total thickness is the arithmetic mean of these two measurements.

6.1.1 Half tiles rectangular in shape shall also be available. Half tiles for use with full tiles in the floor shall have dimensions which shall be such as to make two half tiles when joined together, to match with the dimensions of the one full tile.

## 7 TOLERANCES

7.1 Tolerances on length or breadth of tiles shall be  $\pm 1$  mm. In addition, the difference in length of side between the longest side and the shorter side in the sample shall not exceed 1 mm.

7.2 Tolerance on thickness shall be  $+ 5$  mm. In addition the difference in thickness between the thickest and the thinnest tile in the sample shall not exceed 3 mm.

### 7.3 Thickness of Wearing Layer

7.3.1 The thickness of wearing layer measured from the top of the chequers shall not be less than 6 mm.

7.3.2 The thickness of the wearing layer shall be measured at several points along the fracture line of the tile that was tested for wet transverse strength. The arithmetic mean of the two measurements which yielded the lowest value shall be the minimum thickness of the wearing layer.

## 8 SPECIAL SHAPE AND SIZE

8.1 Shapes and sizes of tiles other than those specified in 6.1 may be manufactured when agreed upon between the supplier and the purchaser but the depth of the grooves shall not be less than 3 mm. The tiles shall also meet all the requirements of the standard.

NOTE — In rectangular tiles, the requirements for the difference in the length of sides as specified in 7.1 shall be applicable both to the length and width of the tiles.

## 9 GENERAL QUALITY

9.1 Unless otherwise specified, the tiles shall be supplied with initial grinding and grouting of the

upper layer. The upper layer of the tiles shall be free from projections, depressions, cracks (hair-cracks not included), holes, cavities and other blemishes. The edges of the tile may be rounded.

## 10 FINISH

10.1 The colour and texture of the wearing layer shall be uniform throughout its thickness. No appreciable difference in the appearance of the tiles, from the point of view of colour of aggregate, its type and its distribution on the surface of the wearing layer shall be present.

## 11 PHYSICAL REQUIREMENT

11.0 The tests on tile shall not be carried out earlier than 28 days from the date of manufacture.

### 11.1 Flatness of the Tile Surface

The tiles when tested according to the procedure laid down in Annex B, the amount of concavity and convexity shall not exceed 1 mm.

### 11.2 Perpendicularity

When tested in accordance with the procedure laid down in Annex C, the longest gap between the arm of the 'square' and the edge of the tiles shall not exceed 2 percent of the length of the edge.

### 11.3 Straightness

When tested according to the procedure given in Annex D, the gap between the thread and the plane of the tile shall not exceed 1 percent of the length of the edge.

### 11.4 Water Absorption

When tested according to the procedure laid down in Annex E, the average percent of water absorption shall not exceed 10.

### 11.5 Wet Transverse Strength

When tested according to the procedure laid down in Annex F, the average wet transverse strength shall not be less than 3 N/mm<sup>2</sup>.

### 11.6 Resistance to Wear

When tested in the manner specified in Annex G, the wear shall not exceed the following value:

- |                                |        |
|--------------------------------|--------|
| a) Average wear                | 2 mm   |
| b) Wear on individual specimen | 2.5 mm |

## 12 MARKING

12.1 Tiles shall be legibly and indelibly marked on the back with the identification of the source of manufacturer.

**12.1.1** Each tile may also be marked with the Standard Mark.

### 13 PACKING

**13.1** The tiles shall be packed according to the usual trade practice and adequately protected.

### 14 SAMPLING AND CRITERION FOR CONFORMITY

**14.1** The consignment of chequered cement concrete flooring tiles shall be divided into a number of lots in accordance with **14.1.1**. Each lot shall be inspected separately for ascertaining its conformity to the requirements of this specification.

#### 14.1.1 Lot

All the chequered cement concrete flooring tiles in a consignment which are of same type, shape and size and manufactured by a single manufacturer from identical raw materials, under identical

conditions of manufacture shall be grouped together to constitute a single lot.

**14.2** The sample of tiles for inspection and testing shall be chosen from a lot at random. For guidance in procedure of random selection IS 4905 : 1968 may be referred.

#### 14.3 Number of Samples and Criterion for Conformity

For each characteristic the number of sample tiles to be selected from a lot and the criterion for determining the conformity of the lot on the basis of the test results on those samples, shall be in accordance with inspection level 1 in Table 1 and AQL 6.5 percent in Table 3 of IS 2500 ( Part 1 ) : 1992.

**14.4** If the samples drawn for testing one characteristic can be utilized for testing any other characteristic, without introducing any prejudice in the test results of the latter, it would not be necessary to take fresh samples for the latter characteristics.

## ANNEX A ( Clause 2.1 )

### LIST OF REFERRED INDIAN STANDARDS

IS No.	Title	IS No.	Title
44 : 1991	Iron oxide pigment for paints ( <i>second revision</i> )	1489 ( Part 2 ) : 1991	Portland pozzolana cement : Calcined clay based ( <i>third revision</i> )
50 : 1980	Lead and scarlet chromes ( <i>third revision</i> )	2500	Sampling inspection tables :
54 : 1988	Green oxide of chromium for paints ( <i>second revision</i> )	( Part 1 ) : 1992	Part 1 Inspection by attributes and by count of defects ( <i>second revision</i> )
55 : 1970	Ultramarine blue for paints ( <i>first revision</i> )	3178 : 1965	Abrasive emery grain
56 : 1975	Prussian blue ( iron blue ) for paints ( <i>first revision</i> )	3574	Organic pigments for paints :
269 : 1989	33 grade ordinary Portland cement ( <i>fourth revision</i> )	( Part 1 ) : 1965	Part 1 Azo pigments
383 : 1970	Coarse and fine aggregates from natural sources for concrete ( <i>second revision</i> )	3574	Organic pigments for paints :
411 : 1991	Titanium dioxide, anatase, for paints ( <i>third revision</i> )	( Part 2 ) : 1966	Part 2 Phthalooyanines
1237 : 1980	Cement concrete flooring tiles ( <i>first revision</i> )	4905 : 1968	Methods for random sampling
1489	Portland pozzolana cement :	8041 : 1990	Rapid hardening Portland cement ( <i>second revision</i> )
( Part 1 ) : 1991	Part 1 Fly ash based ( <i>third revision</i> )	8042 : 1989	White Portland cements ( <i>second revision</i> )

**ANNEX B**  
( *Clause 11.1* )

**METHOD OF DETERMINATION OF FLATNESS OF TILE SURFACE**

**B-1** Six full size tiles selected in accordance with 14 shall be tested in the manner specified in B-2 to B-4.

**B-2** The flatness of the tile surface is tested by means of a metal ruler, whose length is not less than the tile diagonal.

**B-3** For testing surfaces that are concave, the ruler is placed on the surface of the tile along one of the diagonals so that the ruler touches the tile at not less than two points. The largest gap

is measured and the test is repeated along the second diagonal. The larger gap is the amount of concavity.

**B-4** For testing surfaces that are convex, the ruler is placed on the surface of the tile along one of the diagonals so that the distances between the ruler and the tile, at the ends of the diagonal, are equal. The largest gap is measured between the ruler and tile and the test is repeated along the second diagonal. The larger gap is the amount of convexity.

**ANNEX C**  
( *Clause 11.2* )

**METHOD OF THE DETERMINATION OF PERPENDICULARITY**

**C-1** Six full size tiles selected in accordance with 14 shall be tested in the manner specified in C-2.

**C-2** One arm of a 'square', the arms of which are longer than the sides of the tile, is placed along one of the edges of the tile, so that the corner of the 'square' touches the corner of the tile. The distance between the other arm of the

'square' and the other edge is measured at the end of the tile. The test is repeated such that two opposite edges shall be tested.

**C-3** The largest gap between the arm of the 'square' and the edge of the tile shall be reported.

**ANNEX D**  
( *Clause 11.3* )

**METHOD FOR DETERMINATION OF STRAIGHTNESS**

**D-1** Six full size tiles selected in accordance with 14 shall be tested in the manner specified in D-2.

**D-2** Two corners of the tile surface shall be connected with a fine thread alongside one of

the tile edges and the largest gap between the thread and the plane is recorded. The test is repeated alongside each of the other edges. The gap between the thread and the plain of the tile shall not exceed 1 percent of the edge length.

**ANNEX E**  
( *Clause 11.4* )

**METHOD FOR DETERMINATION OF WATER ABSORPTION**

**E-1** Six full size tiles selected in accordance with 14 shall be used for the test. They shall be immersed in water for 24 hours, then taken out and wiped dry.

**E-2** Each tile shall be weighed immediately after saturation and wiping as in E-1. The tile shall then be dried to a constant weight in an oven maintained at  $110 \pm 5^\circ\text{C}$ , cooled to room temperature and reweighed.

**E-3** The water absorption for each tile shall be

determined as follows :

$$\text{Water absorption, percent by mass} = \frac{M_1 - M_2}{M_1} \times 100$$

where

$M_1$  = mass in g of the saturated specimen, and

$M_2$  = mass in g of the oven-dried specimen.

**E-4** The average value shall be reported.

## ANNEX F ( Clause 11.5 )

### METHOD FOR DETERMINATION OF WET TRANSVERSE STRENGTH

**F-1** Six full size tiles selected in accordance with 14 shall be tested wet after soaking in water for 24 hours.

**F-2** The specimen shall be placed horizontally on two parallel steel supports, with wearing surface upwards and its sides parallel to the supports. At least one of the supports shall be self-adjusting.

**F-3** The load shall be applied by means of a steel rod parallel to the supports and midway between them. The length of the supports and of the loading rod shall be longer than the tile. Their diameter shall be 12 mm. The surface of the rod and supports in contact with the tile shall be rounded. The span between the supports shall be as follows:

Size of Tile mm	Span mm
200 × 200	150
250 × 250	200
300 × 300	250

**F-4** A plywood padding about 3 mm thick and 20 mm wide shall be placed between the tile and

each of the supports and between the tile and the steel rod. The length of the padding shall be at least as long as the tile.

**F-5** The load shall be applied gradually and at a uniform rate not exceeding 2000 N per minute, until the tile breaks.

**F-6** The load  $P$  which caused the breaking of the tiles shall be recorded. The thickness shall be determined as the average of two measurements at the location of the fracture, 50 mm from each edge (7.3). The wet transverse strength  $f$  shall be calculated as follows :

$$f = \frac{3Pl}{2bt^2} \text{ N/mm}^2$$

where

$P$  = breaking load in  $N$ ,

$l$  = span between supports in mm,

$b$  = tile width in mm, and

$t$  = fracture thickness of the tiles measured from the fracture line in mm

**F-7** The average wet transverse strength shall be reported.

## ANNEX G ( Clause 11.6 )

### METHOD FOR DETERMINATION OF RESISTANCE TO WEAR

#### G-1 METHOD

**G-1.1** Six full size tiles selected in accordance with 14 shall be tested in the manner specified in G-1.2 to G-1.5.

#### G-1.2 Preparation of Test Specimens

The test specimens shall be square in shape and of size 70.6 mm × 70.6 mm ( that is, 500 mm<sup>2</sup> in area ). They shall be sawn off one only from each tile, preferably from the central part of the tile. The deviation in the length of the specimen shall be within ± 2 percent. The surface to be tested shall be ground smooth and filling removed.

#### G-1.3 Apparatus and Accessories

##### G-1.3.1 Abrasion Testing Machine

The abrasion of specimens shall be carried out in a machine conforming essentially to the requirement given in G-2.

**G-1.3.2** The abrasive powder used for the test shall conform to the requirements given in G-3.

##### G-1.3.3 Measuring Instrument

A suitable instrument capable of measurements to an accuracy of 0.01 mm shall be used for determining the change in the thickness of the specimen after abrasion.

#### NOTES

**1** The arrangement for measurement of thickness with the instrument may be as given in Fig. 1. Shoulders A and B are right angles and the base C is machined at top to an accuracy of 0.01 mm. The test specimen shall be placed on the base with its wearing surface upwards and sides in contact with the shoulders. The measuring instrument ( or dial gauge ) shall be set up firmly so that the contractor slightly presses on the surface of the specimen and the reading of the instrument taken. The position of the dial gauge and the sitting of the contractor shall be the same during the subsequent measurement after abrasion.

**2** The measurement for thickness both before and after the test shall be taken at five points ( one at the centre and four at the corners ) as shown in Fig. 2.

##### G-1.4 Procedure of Test

The specimens shall be dried at 110 ± 5°C for 24 hours and then weighed to the nearest 0.1 g.

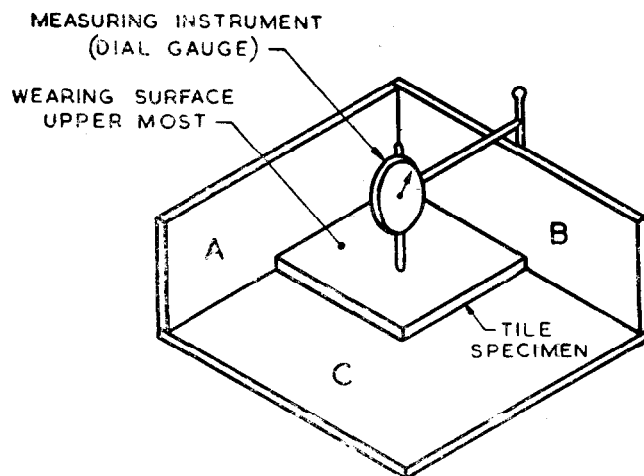
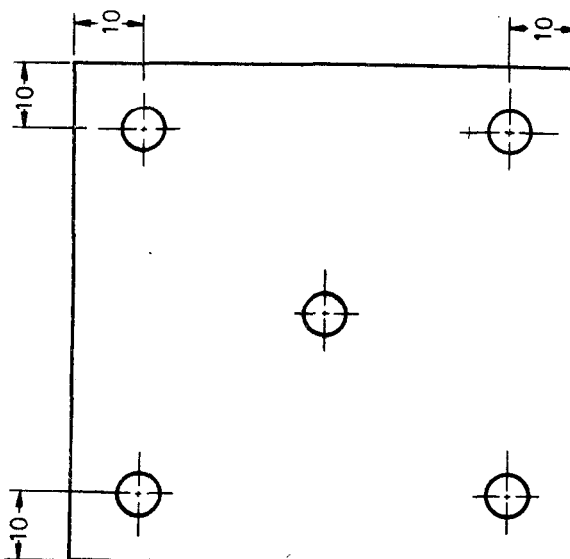

FIG. 1 ARRANGEMENT FOR MEASUREMENT OF THICKNESS



All dimensions in millimetres.

FIG. 2 POINTS SHOWING MEASUREMENT OF THICKNESS

The specimen after initial drying and weighing shall be placed in the thickness-measuring apparatus (see Note 1 below G-1.3.3) with its wearing surface upwards and the reading of the measuring instrument taken.

**G-1.4.1** The grinding path of the disc of the abrasion testing machine (see G-2) shall be evenly strewn with 20 g of the abrasive powder. The specimen shall then be fixed in the holding device with the surface to be ground facing the disc, and loaded at the centre with 300 N. The grinding disc shall then be put in motion at a speed of 30 rev/min and the abrasive powder is continuously fed back on to the grinding path so that it remains uniformly distributed in a track corresponding to the width of the test piece. After every 22 revolutions, the disc shall be stopped, the abraded tile powder and the remainder of the abrasive powder shall be removed from the disc, and fresh abrasive powder

in quantities of 20 g applied each time. After every 22 revolution the specimen shall be turned about the vertical axis through an angle of 90° in the clockwise direction and it should be repeated 9 times thereby giving total number of revolutions of 220. The disc, the abrasive powder and the specimen shall be kept dry throughout the duration of the test. After the abrasion is over, the specimen shall be reweighed to the nearest 0.1 g. It shall then be placed in the thickness measuring apparatus once again in an identical manner and the reading taken with the same position and setting of the dial guage as for the measurement before abrasion.

**NOTE** — If, after the specimen has been subjected to the abrasion test, it is found that the tile has chipped off at any of the points of measurement, that measurement should be discarded in calculating the average. However, a minimum of three residual measurements on a specimen should be ensured.



### G-1.5 Determination of Wear

The wear shall be determined from the difference in readings obtained by the measuring instrument before and after the abrasion of the specimen. The value shall be checked up with the average loss in thickness of the specimen obtained by the following formula :

$$t = \frac{(W_1 - W_2) V_1}{W_1 \cdot A}$$

where

$t$  = average loss in thickness in mm,

$W_1$  = initial mass of the specimen in g,

$W_2$  = final mass of the abraded specimen in g,

$V_1$  = initial volume of the specimen in mm<sup>3</sup>,  
and

$A$  = surface area of the specimen in mm<sup>2</sup>

**G-1.6** The average wear and the wear on individual specimens shall be reported.

## G-2 ESSENTIAL REQUIREMENTS OF THE ABRASION TESTING MACHINE

### G-2.1 General

The testing apparatus shall be a grinding device consisting essentially of a horizontally fixed smooth grinding disc of about 750 mm diameter rotating about a vertical axis and furnished with a replaceable grinding path. The essential features are shown in Fig. 3.

### G-2.2 Grinding Path

**G-2.2.1** Cast iron shall be used as the material for grinding path. Its scaleroscope hardness shall lie between 30 and 50. This hardness shall be ascertained at least 10 times on the rim and

at several points in the grinding path by means of a Shore's scaleroscope with diamond hammer.

**G-2.2.2** The grinding path shall be a 200 mm wide annular space on the grinding disc between distances of 120 and 320 mm from the centre. The grinding path shall be repaired and restored when it has worn out by more than 0.5 mm after use or when the furrows formed in it exceed 0.2 mm in depth. When the grinding path is restored, its hardness shall be determined afresh. When irreparable, it shall be changed.

### G-2.3 Rotation Disc

The disc shall be driven at 30 revolutions per minute. The speed of rotation shall not deviate by more than one revolution per minute. There shall be automatic mechanisms for counting, indicating the revolutions of the disc and for stopping the disc after every 22 revolutions. Such mechanisms shall be checked for reliability prior to the test.

### G-2.4 Holding Device for Test Specimen

The holding device shall consist of a square frame, open on one side and made of cast iron or steel, it shall be of about 40 mm height, with its lower edge about 5 mm above the surface of the grinding disc and so positioned that its centre is at a distance of 220 mm from the centre of the disc. It shall necessarily, but loosely, hold the specimen.

### G-2.5 Loading Device

**G-2.5.1** The loading device shall consist of a steel lever. A short arm of the lever shall be provided with a counter weight just to balance the weight of the long arm and of the weighing disc, so that the pressure stamp just touches the specimen prior to the loading.

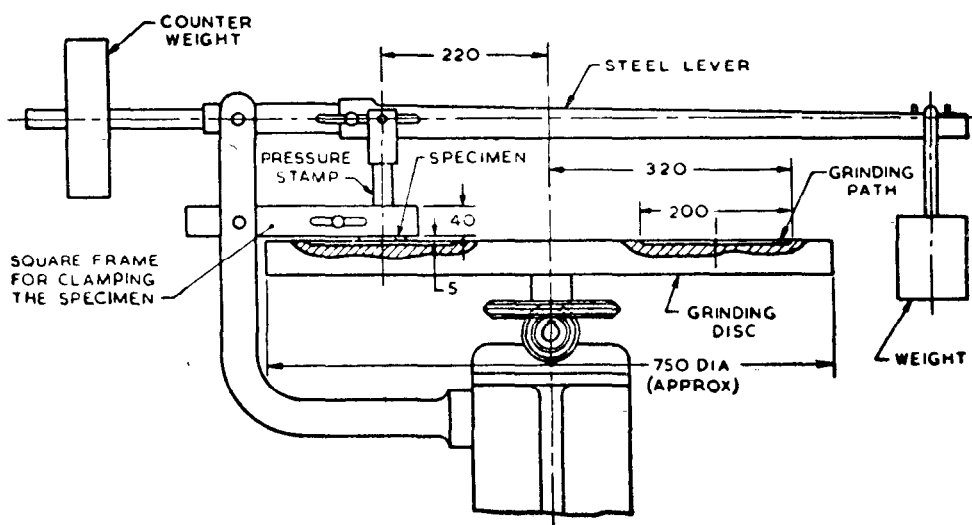

All dimensions in millimetres.

FIG. 3 GENERAL FEATURES OF ABRASION TESTING MACHINES

**G-2.5.2** The lever shall move freely about the fulcrum without appreciable friction. During test, the lever shall remain nearly parallel to the upper surface of the disc. The connection of the pressure stamp to the lever shall be through a self-aligning joint permitting free relative movement but at the same time ensuring a central load on the specimen being tested.

**G-2.5.3** Suitable loading weight shall be applied at the end of the long arm of the lever so that, as magnified by the leverage, a net load of 300 N is applied through the pressure stamp on to the specimen. The load shall be applied with a permissible deviation of one percent. The accuracy of the load shall be verified both by calculation and by measurement with suitable instruments.

### **G-3 REQUIREMENT FOR ABRASIVE POWDER TO BE USED IN THE ABRASION TEST**

#### **G-3.1 Chemical Composition**

**G-3.1.1** The abrasive powder shall have a aluminium oxide content of not less than 95 percent by mass.

#### **G-3.2 Shape and Size**

The grains shall be of rounded shape. The size shall conform to the requirements given in Grit 60 of IS 3178 : 1965.

#### **G-3.3 Specific Gravity**

The specific gravity of the grains shall be between 3.9 to 4.1.

#### **G-3.4 Hardness**

The grains shall generally have a hardness of 9 in Moh's scale.

## **ANNEX H**

( Foreword )

### **COMMITTEE COMPOSITION**

#### **Flooring, Wall Finishing and Roofing Sectional Committee, CED 5**

<p><i>Chairman</i> SHRI P. KRISHNAN</p> <p><i>Members</i> DR P.S. AGGARWAL SHRI M. P. CHITRE SHRI R. N. BISWAS ( Alternate ) BRIG. W. S. CHONA SHRI MANMOHAN SINGH ( Alternate ) DY CHIEF ENGINEER ( P &amp; D ) SR ENGINEER ( P &amp; D ) ( Alternate ) DIRECTOR SHRI R. SRINIVASAN ( Alternate ) DIRECTOR RESEARCH OFFICER ( Alternate ) SHRI O. P. GUPTA DR V. S. GUPTA DR P. K. GHOSH ( Alternate ) SHRI D. K. KANUNGO SHRI R. KAPOOR ( Alternate ) SHRI A. C. KAPOOR SHRI S. C. KAPOOR ( Alternate ) SHRI R. C. KEHAR SHRI B. B. KUMAR ( Alternale ) SHRI MUZZAFAR ALI KHAN SHRI R. C. MANGAL  DR S. P. MANIK SHRI A. K. LAL SHRI A. G. DHANGADE ( Alternate ) SHRI N. N. ROHATGI SHRI T. K. ROY SHRI B. B. BANERJEE ( Alternate ) SHRI B. SHAH SHRI K. L. SHAH SHRI R.D. PATEL ( Alternate ) SHRI J. S. SHARMA SHRI R. S. SHUKLA SHRI S. SUNDRAM SHRI RAJENDER PAL ( Alternate ) SUPERINTENDING ENGINEER EXECUTIVE ENGINEER ( Alternate )</p>	<p><i>Representing</i> Central Public Works Department, New Delhi  Central Glass and Ceramic Research Institute, Calcutta Indian Oil Corporation Limited, New Delhi  Engineer-in-Chief's Branch, New Delhi  Ministry of Railways ( Research, Designs and Standards Organization ), New Delhi Coromandel Prodorite, Madras  Maharashtra Engineering Research Institute, Nasik  Municipal Corporation of Delhi, Delhi Projects and Development India Limited, Sindri, Dhanbad  National Test House, Calcutta  Modern Tiles and Marble, New Delhi  National Buildings Construction Corporation Ltd, Delhi  Indian Institute of Architects, Bombay In Personal Capacity ( 47, Godavari Apartments, Alakananda, Kalkaji, New Delhi-110019. Research, Designs and Standards Organization, Lucknow National Buildings Organization, New Delhi  Institution of Engineers ( India ), Calcutta STP Limited, Calcutta  Steel Authority of India Ltd, New Delhi Bhor Industries Ltd, Bombay  Central Building Research Institute ( CSIR ), Roorkee In Personal Capacity ( B-190, Sector 55, Noida, U. P. ) Ceat Tyres of India Limited, Hyderabad  Public Works Department, Government of Tamil Nadu</p>
---	--

( Continued on page 9 )

*(Continued from page 8)**Members*

SUPERINTENDING SURVEYOR OF WORKS  
( NDZ )-III  
SURVEYOR OF WORKS — 3 ( *Alternate* )  
SHRI W. N. TALWAR  
SHRI PAWAN TALWAR ( *Alternate* )  
SHRI Y. R. TANEJA  
DIRECTOR-IN-CHARGE ( CIV ENGG )

*Representing*

Central Public Works Department, New Delhi  
Builder's Association of India, Bombay  
Director General, BIS ( *Ex-officio Member* )

*Secretary*

SHRI R. S. JUNEJA  
Deputy Director ( Civ Engg ), BIS

## Cement Concrete Flooring and Other Miscellaneous Works Subcommittee, CED 5:7

*Convener*

SHRI P. KRISHNAN

*Members*

SHRI A. C. KAPOOR  
SHRI SUBHASH KAPOOR ( *Alternate* )  
SHRI S. K. MALIK  
SHRI G. C. SHARMA  
SHRI NARESH KOCHAR ( *Alternate* )  
SHRI R. S. SRIVASTAVA  
SHRI R. S. GUPTA ( *Alternate* )  
SHRI BORALINGIAH  
SHRI P. N. TALWAR  
SHRI W. N. TALWAR ( *Alternate* )  
SHRI R. C. KOCHAR  
SHRI SUSHIL KUMAR ( *Alternate* )  
SHRI O. P. GUPTA  
SHRI M. L. TIKKO  
SHRI RAVINDRA ( *Alternate* )  
SHRI S. M. CHAKRAVARTY  
SHRI RAJENDER KAPOOR  
SHRI T. CHOUDHARY ( *Alternate* )

*Representing*

Central Public Works Department, New Delhi  
Modern Tiles and Marble  
Engineer-in-Chief's Branch  
Indian Institute of Architects  
CBRI, Roorkee  
Builder's Association of India, Bombay  
NITCO Tiles Pvt Ltd, Bombay  
National Buildings Construction Corporation, New Delhi  
Municipal Corporation of Delhi, New Delhi  
Delhi Development Authority, New Delhi  
Cement Manufacturers Association, Delhi  
National Test House, Calcutta

### **Standard Mark**

The use of the Standard Mark is governed by the provisions of the *Bureau of Indian Standards Act, 1986* and the Rules and Regulations made thereunder. The Standard Mark on products covered by an Indian Standard conveys the assurance that they have been produced to comply with the requirements of that standard under a well defined system of inspection, testing and quality control which is devised and supervised by BIS and operated by the producer. Standard marked products are also continuously checked by BIS for conformity to that standard as a further safeguard. Details of conditions under which a licence for the use of the Standard Mark may be granted to manufacturers or producers may be obtained from the Bureau of Indian Standards.

## Bureau of Indian Standards

BIS is a statutory institution established under the *Bureau of Indian Standards Act, 1986* to promote harmonious development of the activities of standardization, marking and quality certification of goods and attending to connected matters in the country.

### Copyright

BIS has the copyright of all its publications. No part of these publications may be reproduced in any form without the prior permission in writing of BIS. This does not preclude the free use, in the course of implementing the standard, of necessary details, such as symbols and sizes, type or grade designations. Enquiries relating to copyright be addressed to the Director (Publications), BIS.

### Review of Indian Standards

Amendments are issued to standards as the need arises on the basis of comments. Standards are also reviewed periodically; a standard along with amendments is reaffirmed when such review indicates that no changes are needed; if the review indicates that changes are needed, it is taken up for revision. Users of Indian Standards should ascertain that they are in possession of the latest amendments or edition by referring to the latest issue of 'BIS Handbook' and 'Standards Monthly Additions'. Comments on this Indian Standard may be sent to BIS giving the following reference :

Doc : No. CED 5 ( 5175 )

### Amendments Issued Since Publication

Amend No.	Date of Issue	Text Affected

## BUREAU OF INDIAN STANDARDS

### Headquarters:

Manak Bhavan, 9 Bahadur Shah Zafar Marg, New Delhi 110002  
Telephones : 331 01 31, 331 13 75

Telegrams : Manaksanstha  
( Common to all Offices )

### Regional Offices :

Central : Manak Bhavan, 9 Bahadur Shah Zafar Marg  
NEW DELHI 110002

Telephone

{ 331 01 31  
331 13 75

Eastern : 1/14 C. I. T. Scheme VII M, V. I. P. Road, Maniktola  
CALCUTTA 700054

{ 37 84 99, 37 85 61  
37 86 26, 37 86 62

Northern : SCO 445-446, Sector 35-C, CHANDIGARH 160036

{ 53 38 43, 53 16 40  
53 23 84

Southern : C. I. T. Campus, IV Cross Road, MADRAS 600113

{ 235 02 16, 235 04 42  
235 15 19, 235 23 15

Western : Manakalaya, E9 MIDC, Marol, Andheri ( East )  
BOMBAY 400093

{ 632 92 95, 632 78 58  
632 78 91, 632 78 92

Branches : AHMADABAD. BANGALORE. BHOPAL. BHUBANESHWAR. COIMBATORE.  
FARIDABAD. GHAZIABAD. GUWAHATI. HYDERABAD. JAIPUR. KANPUR.  
LUCKNOW. PATNA. THIRUVANANTHAPURAM.

**AMENDMENT NO. 1 SEPTEMBER 1994  
TO  
IS 13801 : 1993 CHEQUERED CEMENT  
CONCRETE TILES — SPECIFICATION**

( Page 4, Annex E-3 ) — Substitute the following for the existing formula:

$$\frac{M_1 - M_2}{M_2} \times 100'$$

( CED 5 )

---

Reprography Unit, BIS, New Delhi, India

**AMENDMENT NO. 2 APRIL 1999**  
**TO**  
**IS 13801 : 1993 CHEQUERED CEMENT CONCRETE**  
**TILES — SPECIFICATION**

( *Page 1, clause 4.1* ) — Substitute the following for the existing clause:

**‘4.1 Cement**

Cement used in the manufacture of tiles shall be 33 grade ordinary Portland cement conforming to IS 269 : 1989 or rapid hardening Portland cement conforming to IS 8041 : 1990 or white Portland cement conforming to IS 8042 : 1989 or Portland pozzolana cement (Fly ash based) conforming to IS 1489 (Part 1) : 1991 and Portland pozzolana cement (calcined clay based) conforming to IS 1489 ( Part 2 ) : 1991.’

[ *Page 1, clause 4.3.1(c)* ] — Substitute ‘IS 56 : 1993’ for ‘IS 56 : 1975’.

( *Page 3, Annex A* ) — Substitute ‘IS 56 : 1993 Prussian blue (iron blue) for paints ( *second revision* )’ for ‘IS 56 : 1975 Prussian blue (iron blue) for paints ( *first revision* )’ and ‘IS 3178 : 1996 Abrasive emery grain ( *first revision* )’ for ‘IS 3178 : 1965 Abrasive emery grain’.

( CED 5 )

**AMENDMENT NO. 3 MARCH 2002**  
**TO**  
**IS 13801 : 1993 CHEQUERED CEMENT CONCRETE**  
**TILES — SPECIFICATION**

[ *Page 1, clause 4.1, ( see also Amendment No. 2 )* ] — Insert the following at the end of the clause:

‘or 43 grade ordinary Portland cement conforming to IS 8112 : 1989 or 53 grade ordinary portland cement conforming to IS 12269 : 1989.’

( *Page 5, clause G-1.2, last sentence* ) — Substitute the following for the existing:

‘The surface to be tested shall be ground to remove the grouting/filling.’

( CED 5 )

---

Reprography Unit, BIS, New Delhi, India



**AMENDMENT NO. 4 JUNE 2003**  
**TO**  
**IS 13801 : 1993 CHEQUERED CEMENT CONCRETE**  
**TILES — SPECIFICATION**

( *Page 1, clause 3.1* ) — Substitute the following for the existing clause:

**3.1 Chequered Tiles**

Chequered tiles, cement tiles or terrazo tiles having grooves on the surface of the tile making it anti-slippery. The area of chequered grooves should not be less than 2 percent of the total surface area of the tile. The chequered groove can be in any shape and length, but the depth of grooves should not be less than 3 mm.'

( CED 5 )