

IS 13769 : 1993
ISO 3449 : 1992

भारतीय मानक

मिट्टी उठाने की मशीनरी – गिरती वस्तुओं से सुरक्षा
की संरचनाएं – प्रयोगशाला परीक्षण और कार्यकारिता
अपेक्षाएं

Indian Standard

**EARTH-MOVING MACHINERY — FALLING-OBJECT
PROTECTIVE STRUCTURES — LABORATORY
TESTS AND PERFORMANCE REQUIREMENTS**

UDC 621'878/9-78

© BIS 1993

BUREAU OF INDIAN STANDARDS
MANAK BHAVAN, 9 BAHADUR SHAH ZAFAR MARG
NEW DELHI 110002

December 1993

Price Group 4

NATIONAL FOREWORD

This Indian Standard which is identical with ISO 3449:1992 'Earth-moving machinery — Falling-object protective structures — Laboratory tests and performance requirements' issued by the International Organization for Standardization (ISO) was adopted by the Bureau of Indian Standards on the recommendations of Bulk Handling Systems and Equipment Sectional Committee and approval of the Heavy Mechanical Engineering Division Council.

The text of ISO standard has been approved for publication as Indian Standard without deviations. Certain terminology and conventions are, however, not identical to those used in Indian Standards. Attention is particularly drawn to the following:

- a) Wherever the words 'International Standard' appear, referring to this standard, they should be read as 'Indian Standard'.
- b) Comma (,) has been used as a decimal marker while in Indian Standards, the current practice is to use a point (.) as a decimal marker.

In this adopted standard, reference appears to certain International Standards for which Indian Standards also exist. The corresponding Indian Standards which are to be substituted in their place are listed below along with their degree of equivalence for the editions indicated:

<i>International Standard</i>	<i>Corresponding Indian Standard</i>	<i>Degree of Equivalence</i>
ISO 148 : 1983	IS 1757 : 1988 Method for charpy impact test (V notch) for metallic material (<i>second revision</i>)	Not equivalent
ISO 898-1 : 1988	IS 1367 (Part 3) : 1991 Fasteners — Threaded steel — Technical supply conditions : Part 3 Mechanical properties and test methods for bolts, screws and studs with full loadability (<i>third revision</i>)	Identical
ISO 898-2	IS 1367 (Part 6) : 1980 Technical supply conditions for threaded steel fasteners : Part 6 Mechanical properties and test methods for nuts with specified proof loads (<i>second revision</i>)	Not equivalent
ISO 3164 : 1979	IS 13768 : 1993 Earth moving machinery — Laboratory evaluations of roll-over and falling-object protective structures — Specifications for the deflection-limiting volume	Identical
ISO 3411	IS 11115 : 1993 Earth moving machinery — Human physical dimensions of operators and minimum operator space envelope (<i>first revision</i>)	Identical
ISO 6165	IS 12138 : 1993 Earth-moving machinery — Basic types — Vocabulary (<i>first revision</i>)	Identical

The concerned technical committee has reviewed the provisions of ISO 3471-1 : 1986 'Earth-moving machinery — Roll-over protective structures — Laboratory tests and performance requirements — Part 1 : Crawler, wheel loaders and tractors, backhoe loaders, graders, tractor scrapers, articulated steer dumpers' referred in this adopted standard and has decided that it is acceptable for use in conjunction with this standard.

In reporting the results of a test or analysis made in accordance with this standard, if the final value, observed or calculated, is to be rounded off, it shall be done in accordance with IS 2 : 1960 'Rules for rounding off numerical values (*revised*)'.

Indian Standard

EARTH-MOVING MACHINERY — FALLING-OBJECT PROTECTIVE STRUCTURES — LABORATORY TESTS AND PERFORMANCE REQUIREMENTS

1 Scope

1.1 This International Standard specifies

- a) the laboratory tests for measurement of structural characteristics, and
- b) the performance requirements in a representative test,

of a falling-object protective structure (FOPS).

1.2 The laboratory tests are a means of testing the characteristics of the structures used to protect the operator from localized impact penetration and, indirectly, of the load-carrying capacity of the supporting structure to resist impact loading.

1.3 This International Standard establishes a consistent, repeatable means of evaluating characteristics of FOPS under loading and prescribes performance requirements for these structures under such loading in a representative test.

NOTE 1 For the purposes of this International Standard, "representative test" means a test of a specimen whose material, dimensional, and processing requirements are typical of those FOPS currently being produced.

1.4 This International Standard applies to the following types of operator-controlled machines, regardless of the type of steering system used, as defined in ISO 6165:

- crawler loaders, wheel loaders and backhoe loaders;
- crawler tractors and wheel tractors;
- graders;
- tractor-scrapers.

1.5 This International Standard does not apply to

- self-propelled compactors;
- drills;
- paving machines;
- machines having a power rating less than 15 kW (20 hp);^d
- belt loaders;
- excavators;
- cranes;
- drag lines.

2 Normative references

The following standards contain provisions which, through reference in this text, constitute provisions of this International Standard. At the time of publication, the editions indicated were valid. All standards are subject to revision, and parties to agreements based on this International Standard are encouraged to investigate the possibility of applying the most recent editions of the standards indicated below. Members of IEC and ISO maintain registers of currently valid International Standards.

ISO 148:1983, *Steel — Charpy impact test (V-notch)*.

ISO 898-1:1988, *Mechanical properties of fasteners — Part 1: Bolts, screws and studs*.

ISO 898-2:—¹⁾, *Mechanical properties of fasteners — Part 2: Nuts with specified proof load values — Coarse thread*.

1) To be published. (Revision of ISO 898-2:1980)

ISO 3164:1979, *Earth-moving machinery — Laboratory evaluations of roll-over and falling-object protective structures — Specifications for the deflection-limiting volume.*

ISO 3411:1982, *Earth-moving machinery — Human physical dimensions of operators and minimum operator space envelope.*

ISO 3471-1:1986, *Earth-moving machinery — Roll-over protective structures — Laboratory tests and performance requirements — Part 1: Crawler, wheel loaders and tractors, backhoe loaders, graders, tractor scrapers, articulated steer dumpers.*

ISO 6165:1987, *Earth-moving machinery — Basic types — Vocabulary.*

3 Definitions and abbreviations

For the purposes of this International Standard, the following definitions and abbreviations apply.

3.1 falling-object protective structure (FOPS): A system of structural members arranged in such a way as to provide operators with reasonable protection from falling objects (for example, trees, rocks, small concrete blocks, hand tools, etc.).

3.2 roll-over protective structure (ROPS): System of structural members arranged on a machine in such a way as to accomplish its primary purpose of reducing the possibility of an operator, when wearing a seat belt, being crushed should his machine roll over. Structural members include any subframe, bracket, mounting, socket, bolt, pins, suspension or flexible shock absorber used to secure the system to the machine frame but excludes mounting provisions which are integral with the machine frame.

3.3 deflection-limiting volume (DLV): That volume, related to the operator, which serves to set limits and deflections permissible when performing laboratory evaluations of FOPS and ROPS. The volume, an approximation, is based on the seated dimensions of a large operator.

4 General

The following points are stated to aid in understanding the underlying principles, intention and application of this International Standard.

4.1 The FOPS can be integrated in the cab of the operator.

4.2 This evaluation procedure will not necessarily duplicate structural deformations due to a given actual impact of falling objects.

4.3 This evaluation procedure is generally destructive of the FOPS assembly, as permanent deformation is apt to occur.

4.4 Two acceptance levels are defined:

a) level I acceptance is intended for protection from falling bricks, small concrete blocks and hand tools encountered in operations such as highway maintenance, landscaping and other construction site services;

b) level II acceptance is intended for protection from falling trees or rocks for machines involved in site clearing, overhead demolition or forestry.

Although FOPS meeting these criteria do not give crush protection under all circumstances in which the machine could be struck from above, it is expected that penetration protection will be ensured under at least the following conditions: a round object dropped from a height sufficient to develop an energy of 1 365 J (level I) or a blunt object (see figure 1) dropped from a height sufficient to develop an energy of 11 600 J (level II).

NOTE 2 Drop height of a standard object is defined as a function of its mass. See figure 3.

4.5 The material temperature requirement of 6.3 is intended to be a base-line of measurement for testing, to ensure that the FOPS will have meaningful resistance to brittle fracture; it does not necessarily relate to operating conditions.

4.6 Because, in an actual situation involving a falling object, loading will be dynamic (possibly impact), the use of conventional "safety factors" based on static force loading should be treated with caution. The "safety factor" of a FOPS is related more to energy absorption capability and details of weld design and welding procedure than it is to static force resistance.

5 Laboratory tests

5.1 Apparatus

5.1.1 Solid steel or ductile iron or other sphere, having a mass of 45 kg (level I), with the sphere diameter not exceeding 250 mm or a **standard laboratory drop test object**, made of steel as shown in figure 1 (level II).

An optional drop test object is a sphere or ball with a maximum diameter of 400 mm and with the capability of developing an energy of 11 600 J for level II.

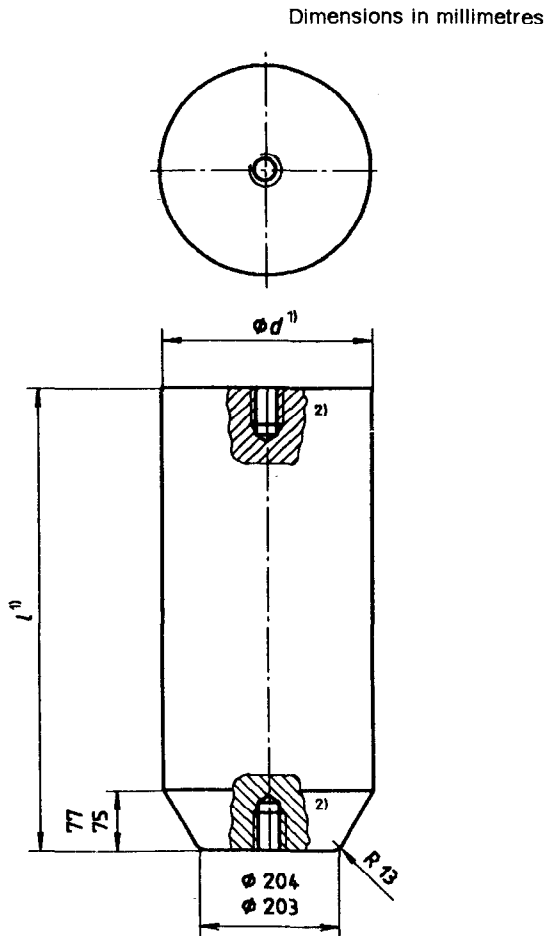

1) Dimensions d and l are optional, depending on the mass of the test object required to match the height of drop that will provide the energy specified in 4.4.

For example, for a drop test object mass of 227 kg:
 $d = 255$ to 260
 $l = 583$ to 585

To determine drop height, see figure 3.

2) May be drilled and tapped for a lifting eye.

Figure 1 — Standard laboratory drop test object

5.1.2 Means of raising the standard object to the required height.

5.1.3 Means of releasing the standard object so that it drops without restraint.

5.1.4 Surface of such firmness that it is not penetrated by the machine or test bed under the loading of the drop test.

5.1.5 Means of determining whether the FOPS enters the deflection-limiting volume during the drop test. This may be either of the following:

- a) a DLV, placed upright, made of a material which will indicate any penetration by the FOPS; grease may be put on the lower surface of the FOPS cover to indicate such penetration;
- b) a dynamic instrumentation system of sufficient frequency response to indicate the relevant deflection with respect to the DLV.

5.2 DLV requirements

The DLV and its location shall be in accordance with ISO 3164. The DLV shall be fixed firmly to the same part of the machine as the operator's seat, and shall remain there during the entire formal test period.

For skid-steer loaders where front access is required and it is necessary to provide protection for the feet separate from other parts of the FOPS, it is permissible that guards invade the DLV in the area above the foot and at the front of the area representing legs and knees. The guards shall not extend into the area that will be occupied by the legs and knees as defined in ISO 3411.

5.3 Test conditions

5.3.1 Measurement accuracy

The measurement accuracy of the deflection of the FOPS shall be $\pm 5\%$ of the maximum deflection measured.

5.3.2 Machine or test bed condition

5.3.2.1 The FOPS to be evaluated shall be attached to the machine structure as it would be in actual machine use. A complete machine is not required; however, the portion on which the FOPS is mounted shall be identical to the actual structure, and the vertical stiffness of a test bed shall be not less than that of an actual machine as described in 5.3.2.2.

5.3.2.2 If the FOPS is mounted on a machine, the following stipulations apply:

- there are no limitations on customary attachments and/or payload;
- all ground-engaging tools shall be in the normal carry position;
- all suspension systems, including pneumatic tyres, shall be set at operating levels. Variable suspensions shall be in the "maximum stiffness" range;

- all cab elements, such as windows, normally removable panels or non-structural fittings, shall be removed so that they do not contribute to the strength of the FOPS.

5.4 Procedure

The test procedure shall consist of the following operations, in the order listed.

5.4.1 Place the standard laboratory drop test object (5.1.1), on top of the FOPS (small end down — level II) at the location designated in 5.4.2.

5.4.2 The small end of the object shall be entirely within the vertical projection of the DLV, in that volume's upright position, on the FOPS top. It is intended that the drop location include at least a portion of the vertical projection of the top plane area of the DLV.

Case 1:

Where major, upper, horizontal members of FOPS do not enter the vertical projection of the DLV on the FOPS top.

The drop test object shall be placed such that it is as close as possible to the centre of gravity of the upper FOPS structure (see figure 2).

Case 2:

Where major, upper, horizontal members of the FOPS do enter the vertical projection of the DLV on the FOPS top.

Where the covering material of all the surface areas above the DLV is of uniform thickness, the centre of the drop test object shall be in the surface of greatest area. This area is the vertical projected area of the DLV without major, upper, horizontal members. The centre of the drop test object shall be at that point, within the surface of greatest area, which has the least possible distance from the centroid of the FOPS top (see figure 2).

Where other materials or a different thickness are used in different areas above the DLV, each area in turn shall be subjected to a drop test. If design features such as cutouts for windows or equipment, or variations in cover material or thickness indicate a more vulnerable location could obviously be selected within the vertical projection of the DLV, the drop location should be adjusted to that location. In addition, if cutouts in the FOPS cover are intended to be filled with devices or equipment to provide adequate protection, those devices or equipment shall be in place during the drop test.

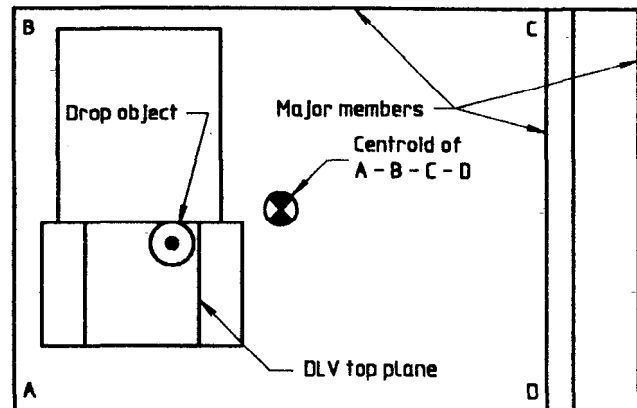

Case 1

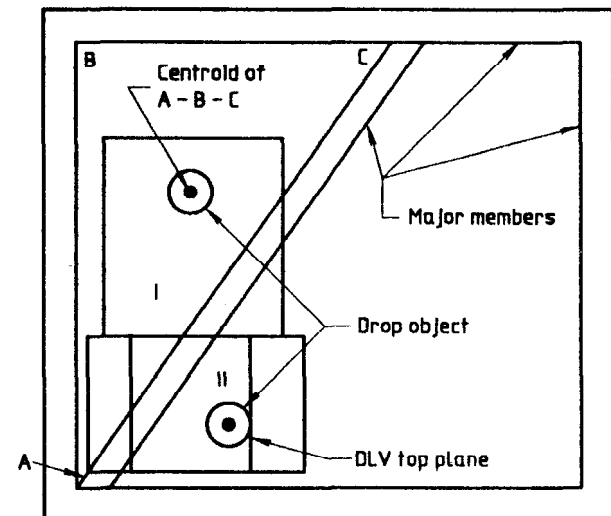

NOTE - I has a greater area than II.

Case 2

Figure 2 — Drop test impact points

5.4.3 Raise the drop test object vertically to a height above the position indicated in 5.4.1 and 5.4.2 to develop energy as specified in 4.4 depending on the type of FOPS.

5.4.4 Release the drop test object so that it falls without restraint onto the FOPS.

5.4.5 As it is unlikely that the free fall will result in the drop test object hitting at the location and/or in the attitude of 5.4.1 and 5.4.2, the following limits are placed on deviations.

5.4.5.1 For a level II FOPS, the initial impact of the small end of the drop test object shall be entirely within a circle of 200 mm radius (the centre of this circle is to coincide with the vertical centre line of

the drop test object as positioned according to 5.4.1 and 5.4.2).

5.4.5.2 For a level I FOPS, the impact of the drop test sphere shall be entirely within a circle of 100 mm radius (the centre of this circle shall coincide with the vertical centre-line of the drop test object as positioned according to 5.4.1 and 5.4.2).

5.4.5.3 For level II FOPS test, the first contact between the test object and the FOPS shall only be along the small end and/or the radius contiguous to that end (see figure 1).

5.4.5.4 There is no limitation on location or attitude of subsequent impacts due to rebound.

6 Performance requirements

6.1 Requirement for FOPS alone

The protective properties of the FOPS system shall be estimated by the ability of the cab or protective structure to resist the impact. The DLV (see ISO 3164) shall not be entered by any part of the protective structure under the first or subsequent impact of the drop test object. Should the drop test object penetrate the FOPS, it shall be considered to have failed the test.

6.2 Requirement for both ROPS and FOPS

Where the structure provides for both ROPS and FOPS, the FOPS shall also meet the performance requirements for the appropriate ROPS as given in ISO 3471. Where ROPS is not involved, a different structure may be used to support the FOPS as long as the DLV is not violated in the test.

The FOPS shall completely cover and overlap the vertical projection of the DLV.

Should the same structure be used for both evaluations, the drop test procedure shall precede the ROPS loading; the removal of impact dents or replacement of the FOPS cover is permitted.

NOTE 3 It is not required that the included volume of a ROPS or FOPS having four or more vertical members entirely enclose the positioned DLV. Nor is it intended that a simple (two-post) frame be excluded as either a FOPS or ROPS.

6.3 Material temperature requirements

6.3.1 The laboratory evaluations shall be performed with FOPS and machine frame members soaked to $-18\text{ }^{\circ}\text{C}$ or below.

6.3.2 If the evaluations are not performed at this temperature, the following minimum material requirements shall be met.

6.3.2.1 Bolts and nuts used to attach the FOPS (or FOPS cover and its supporting structure) to the machine frame and to connect structural parts to the FOPS cover shall be property class 8.8 or 10.9 bolts (see ISO 898-1) and 8 or 10 property class nuts (ISO 898-2).

6.3.2.2 Structural members of the FOPS and ROPS (or FOPS cover) and the mounts which attach them to the machine frame when made from steel shall have one of the following Charpy V-notch impact strengths (see ISO 148):

10 mm \times 10 mm specimen: 10,8 J at $-30\text{ }^{\circ}\text{C}$

10 mm \times 7,5 mm specimen: 9,5 J at $-30\text{ }^{\circ}\text{C}$

10 mm \times 5 mm specimen: 7,5 J at $-30\text{ }^{\circ}\text{C}$

10 mm \times 2,5 mm specimen: 5,5 J at $-30\text{ }^{\circ}\text{C}$

Structural members made from materials other than steel shall have equivalent low temperature impact resistance.

Specimens are to be "longitudinal" and taken from flat stock, tubular, or structural sections before forming or welding for use in FOPS. Specimens from tubular or structural sections are to be taken from the middle of the side of greatest dimension and shall not include welds.

NOTE 4 The requirements of 6.3.2.2 are given until such time as ISO develops an International Standard.

7 Labelling

7.1 A label shall be applied to every FOPS. When the structure meets the performance requirements for both FOPS and ROPS, the labelling shall be as described in ISO 3471.

7.1.1 Label specification

7.1.1.1 The label shall be of a permanent type and permanently attached to the structure.

7.1.1.2 The label shall be located on the structure so that it can be easily read and is protected from defacing by weather.

7.1.2 Label content

The label shall provide the following minimum information:

a) name and address of the manufacturer or constructor of the FOPS;

- b) FOPS identification number, if any;
- c) machine make, model(s), or serial number(s) the structure is designed to fit;
- d) the International Standard number(s) for which the structure meets all of the performance requirements and the level being met. National regulations may be included.

NOTE 5 The manufacturer may include such other information as deemed appropriate (for example, installation, repair or replacement information).

8 Reporting of test results

The test report shall include the results of the test and be presented in a typical test report according to annex A. Additional information presented in annex B shall be reported only to the originator of the test request.

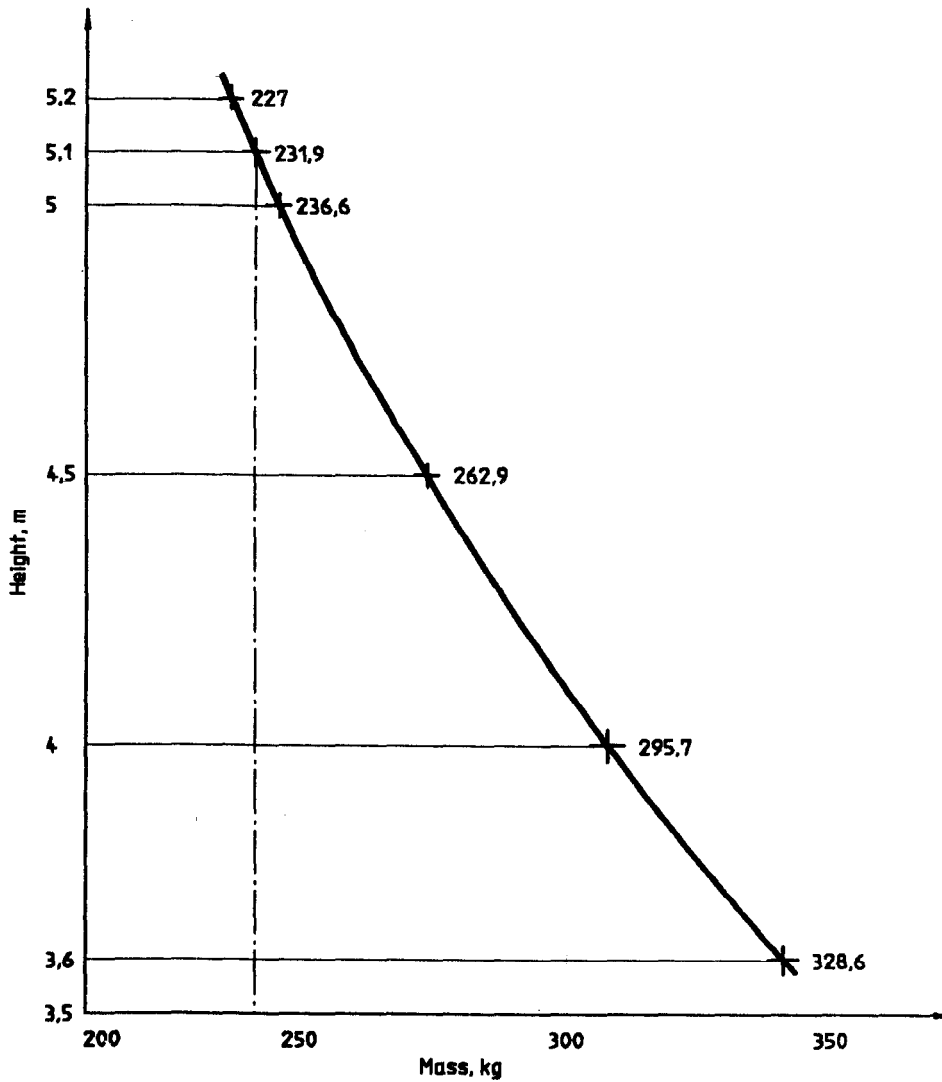

Figure 3 — Height and mass for drop test object with capability of developing energy of 11 600 J

Annex A
(normative)

Standard test report

(See clause 8)

A.1 Identification

A.1.1 Machine(s)

Type:
Manufacturer:
Model:
Serial number (if any):
Machine frame part number:

A.1.2 FOPS

Manufacturer:
Model:
Serial number (if any):
FOPS (may include ROPS) part number:

**A.2 Information supplied by
manufacturer(s)**

Location of DLV:

A.3 Conclusion

Confirm the test results by the following:

- 1) The minimum performance requirements of ISO 3449 were met (not met) in this test.
- 2) Date of test.
- 3) Name and address of the test facility.
- 4) Tested by (signature).
- 5) Date of report.

Annex B (normative)

Test report — Additional information for originator of test request

(See clause 8)

B.1 Drop test object

B.1.1 Standard:

- diameter: mm
- length: mm
- mass: kg

B.1.2 Ball:

- diameter: mm
- mass: kg

B.1.3 Height of fall for the test: m

B.2 Photographs

B.2.1 One photograph of drop test object and test arrangement before application of drop test(s).

B.2.2 Photographs as necessary to show top and bottom of FOPS structure after application of drop test(s).

B.3 Test results

B.3.1 Drop test

Energy imparted to the drop test object without causing penetration of any part of the FOPS structure into the DLV nor penetration of the FOPS by the drop test object: J

B.3.2 Material temperature

- a) The test was performed with FOPS and machine frame members soaked to °C or verification of the Charpy V-notch impact strength requirements for FOPS and ROPS (or FOPS cover) structural metallic members.
- b) Verification of the property class requirements for bolts and nuts (see 6.3.2.1).

Standard Mark

The use of the Standard Mark is governed by the provisions of the *Bureau of Indian Standards Act, 1986* and the Rules and Regulations made thereunder. The Standard Mark on products covered by an Indian Standard conveys the assurance that they have been produced to comply with the requirements of that standard under a well defined system of inspection, testing and quality control which is devised and supervised by BIS and operated by the producer. Standard marked products are also continuously checked by BIS for conformity to that standard as a further safeguard. Details of conditions under which a licence for the use of the Standard Mark may be granted to manufacturers or produceres may be obtained from the Bureau of Indian Standards.

Bureau of Indian Standards

BIS is a statutory institution established under the *Bureau of Indian Standards Act, 1986* to promote harmonious development of the activities of standardization, marking and quality certification of goods and attending to connected matters in the country.

Copyright

BIS has the copyright of all its publications. No part of these publications may be reproduced in any form without the prior permission in writing of BIS. This does not preclude the free use, in the course of implementing the standard, of necessary details, such as symbols and sizes, type or grade designations. Enquiries relating to copyright be addressed to the Director (Publications), BIS.

Revision of Indian Standards

Amendments are issued to standards as the need arises on the basis of comments. Standards are also reviewed periodically; a standard along with amendments is reaffirmed when such review indicates that no changes are needed; if the review indicates that changes are needed, it is taken up for revision. Users of Indian Standards should ascertain that they are in possession of the latest amendments or edition by referring to the latest issue of 'BIS Handbook' and 'Standards Monthly Addition'. Comments on this Indian Standard may be sent to BIS giving the following reference:

Doc : No. HMD 07 (0205)

Amendments Issued Since Publication

Amend No.	Date of Issue	Text Affected

BUREAU OF INDIAN STANDARDS

Headquarters:

Manak Bhavan, 9 Bahadur Shah Zafar Marg, New Delhi 110002

Telephones : 331 01 31, 331 13 75

Telegrams : Manaksanstha
(Common to all Offices)

Regional Offices :

Central : Manak Bhavan, 9 Bahadur Shah Zafar Marg
NEW DELHI 110002

Telephone

{ 331 01 31
{ 331 13 75

Eastern : 1/14 C. I. T. Scheme VIII M, V. I. P. Road, Maniktola
CALCUTTA 700054

{ 37 84 99, 37 85 61
{ 37 86 26, 37 86 62

Northern : SCO 445-446, Sector 35-C, CHANDIGARH 160036

{ 53 38 43, 53 16 40
{ 53 23 84

Southern : C. I. T. Campus, IV Cross Road, MADRAS 600113

{ 235 02 16, 235 04 42
{ 235 15 19, 235 23 15

Western : Manakalaya, E9 MIDC, Marol, Andheri (East)
BOMBAY 400093

{ 632 92 95, 632 78 58
{ 632 78 91, 632 78 92

Branch : AHMADABAD. BANGALORE. BHOPAL. BHUBANESHWAR. COIMBATORE.
FARIDABAD. GHAZIABAD, GUWAHATI. HYDERABAD. JAIPUR. KANPUR
LUCKNOW. PATNA. THIRUVANANTHPURAM.