

भारतीय मानक

इस्पात के चूड़ीदार बंधकों की तकनीकी पूर्ति शर्तें

भाग 9 सतह विच्छिन्नताएँ

अनुभाग 2 विशेष अनुप्रयोग के काबले, पेंच और स्टड

(तीसरा पुनरीक्षण)

Indian Standard

**TECHNICAL SUPPLY CONDITIONS FOR THREADED
STEEL FASTENERS**

PART 9 SURFACE DISCONTINUITIES

Section 2 Bolts, Screws and Studs for Special Applications

(Third Revision)

First Reprint SEPTEMBER 1998

UDC 621'882'2'082

© BIS 1993

BUREAU OF INDIAN STANDARDS
MANAK BHAVAN, 9 BHADUR SHAH ZAFAR MARG
NEW DELHI 110002

NATIONAL FOREWORD

This Indian Standard IS 1367 (Part 9/Sec 2) which is identical with ISO 6157-3 : 1988 'Fasteners — Surface discontinuities Part 3 : Bolts, screws and studs for special requirements' issued by International Organization for Standardization (ISO) was adopted by the Bureau of Indian Standards on the recommendation of the Bolts, Nuts and Fasteners Accessories Sectional Committee (LM 14) and approval of Light Mechanical Engineering Division Council.

The second revision of the standard [IS 1367 (Part 9)] published in 1979 was based on Draft International Standard ISO/DIS 6157/1 'Fasteners—surface discontinuities—Part 1 : Bolts, screws and studs with thread sizes M5 to M39' issued by ISO. The standard was covering the surface discontinuities of fasteners for general applications as well as special applications. The revision has been made to harmonize with the International Standards ISO 6157-1 : 1988 and ISO 6157-3 : 1988 to cover general applications as well as special applications separately in Section 1 and Section 2 of IS 1367 (Part 9). The following major changes have been made in this revision:

- a) The dents, nicks and gouges located at the first three threads accepting the torque values has been increased to '001d⁸ Max.
- b) The forging bursts limitations has been specified separately for width and depth.
- c) The limits of shear bursts values have also been extended for hexagon head screws and circular head screws.
- d) The figures showing permissible and not permissible forging cracks in socket head screws has been extended for button head and countersunk screws.
- e) The limit of combined surface area of all voids on the bearing face has been reduced to 5 percent of the total area.
- f) The folds at the surface of bolt end has been permitted.

In the adopted standard, certain terminology and conventions are not identical with those used in Indian Standards; attention is specially drawn to the following:

- a) Wherever the words 'International Standard' appear referring to this standard, they should be read as 'Indian Standard'.
- b) Comma (,) has been used as a decimal marker in the International Standard while in Indian Standards, the current practice is to use a point (.) as the decimal marker.

In this adopted standard reference appears to certain International Standards for which Indian Standards also exist. The corresponding Indian Standards which are to be substituted in their place are listed below along with their degree of equivalence for the editions indicated.

<i>International Standard</i>	<i>Corresponding Indian Standard</i>	<i>Degree of Equivalence</i>
ISO 898-1 : 1988	IS 1367 (Part 3) : 1991 Fasteners — Threaded steel — Technical supply conditions : Part 3 Mechanical properties and test methods for bolts, screws and studs with full loadability (<i>third revision</i>)	Identical
ISO 2859* ISO 2859-1 : 1989	IS 2500 (Part 1) : 1992 Sampling inspection procedures : Part 1 Attribute sampling plans index by acceptable quality level (AQL) for lot by lot inspection (<i>second revision</i>)	Identical
ISO 3269 : 1984	IS 1367 (Part 17) : Technical supply conditions for threaded steel fasteners — Acceptance criteria (<i>under preparation</i>)	†

The concerned technical committee has reviewed the provision of ISO 468 and ISO 3269 referred in this adopted standard and has decided that these are acceptable for use in conjunction with this standard. The related Indian Standard to ISO 468 : 1982 is IS 3073 : 1967 'Assessment of surface roughness'.

* ISO 2859 has since been revised into parts. However only relevant part has been shown in the reference.

† This standard is likely to be adopted as Indian Standard with minor modifications.

Indian Standard

TECHNICAL SUPPLY CONDITIONS FOR THREADED STEEL FASTENERS

PART 9 SURFACE DISCONTINUITIES

Section 2 Bolts, Screws and Studs for Special Applications

(Third Revision)

1 Scope and field of application

1.1 This part of ISO 6157 establishes limits for various types of surface discontinuities on bolts, screws and studs for special requirements.

It applies to bolts, screws and studs with

- nominal thread diameters 5 mm and larger;
- product grades A and B;
- nominal lengths $l < 10d$ (or longer if specified);
- property class 12.9;
- property classes 8.8, 9.8 and 10.9 when specified in product standards or agreed between supplier and purchaser.

1.2 Where the permissible limits for surface discontinuities indicated in clause 3 occur, the minimum values for the mechanical and functional properties specified in ISO 898-1 should still be met.

When fatigue strength requirements are specified, the fatigue strength should not be lower than that obtained on bolts without defects taken from the same lot.

NOTES

1 The figures in clause 3 are examples only. They apply correspondingly also to other types of bolts, screws and studs.

2 The individual figures show the surface discontinuities exaggerated in some cases for clarity.

2 References

ISO 468, *Surface roughness — Parameters, their values and general rules for specifying requirements.*

ISO 898-1, *Mechanical properties of fasteners — Part 1: Bolts, screws and studs.*

ISO 2859, *Sampling procedures and tables for inspection by attributes.*

ISO 3269, *Fasteners — Acceptance inspection.*

3 Types, causes, appearance and limits of surface discontinuities

3.1 Cracks

A crack is a clean (crystalline) fracture passing through or across the grain boundaries and may possibly follow inclusions of foreign elements. Cracks are normally caused by overstressing the metal during forging or other forming operations, or during heat treatment. Where parts are subjected to significant reheating, cracks usually are discoloured by scale.

3.1.1 Quench cracks

Cause	Quench cracks may occur during hardening due to excessively high thermal and transformation stresses. Quench cracks usually follow an irregular and erratic course on the surface of the fastener.
Appearance	<p>Quench crack circumferential and adjacent to fillet</p> <p>Quench crack across washer face and to depth of washer face thickness</p> <p>Quench crack at corner of head</p> <p>Transverse quench crack</p> <p>Longitudinal quench crack</p> <p>Quench crack at root</p> <p>Quench crack, section at crest of thread missing</p> <p>Quench crack across top of head. Usually an extension of crack in shank or side of head</p> <p>Quench crack extending radially into fillet</p> <p>A-A</p> <p>Quench crack at root</p> <p>Quench crack</p>
Limits	Quench cracks of any depth, any length, or in any location are not permitted.

3.1.2 Forging cracks

Cause	Forging cracks may occur during the cut-off or forging operations and are located on the top of the head of screws and bolts.
Appearance	<p>Forging crack on top of head</p>
Limits	<p>Length, l, of forging cracks: $l < d^1$)</p> <p>Depth or width, b, of forging cracks: $b < 0,04d$</p> <p>NOTE – The limits for forging cracks do not apply to socket head screws (see 3.1.5).</p> <p>1) d = nominal thread diameter</p>

3.1.3 Forging bursts

Cause	Forging bursts may occur for example during forging on the flats or corners of the heads of bolts and screws, at the periphery of flanged or circular head products or on the raised periphery of indented head bolts and screws.
Appearance	
Limits	<p>Hexagon head screws</p> <p>No forging burst in the flats of hexagon bolts and screws shall extend into the crown circle on the top of the head surface (chamfer circle) or into the underhead bearing surface. Forging bursts occurring at the intersection of two wrenching flats shall not reduce the width across corners below the specified minimum.</p> <p>Forging bursts in the raised periphery of indented head bolts and screws shall not exceed a width of $0,06d^{1)}$ or have a depth extending below the indented portion.</p> <p>Circular head screws</p> <p>Flanges of bolts and screws and peripheries of circular head screws may have forging bursts, but they shall not exceed the following limits:</p> <p>Width of forging bursts:</p> <p>$0,08d_c^{2)}$ (with only one forging burst);</p> <p>$0,04d_c$ (with two or more forging bursts, one of which may extend to $0,08d_c$).</p> <p>Depth of forging bursts:</p> <p>$0,04d^{1)}$</p> <p>1) d = nominal thread diameter 2) d_c = head or flange diameter</p>

3.1.4 Shear bursts

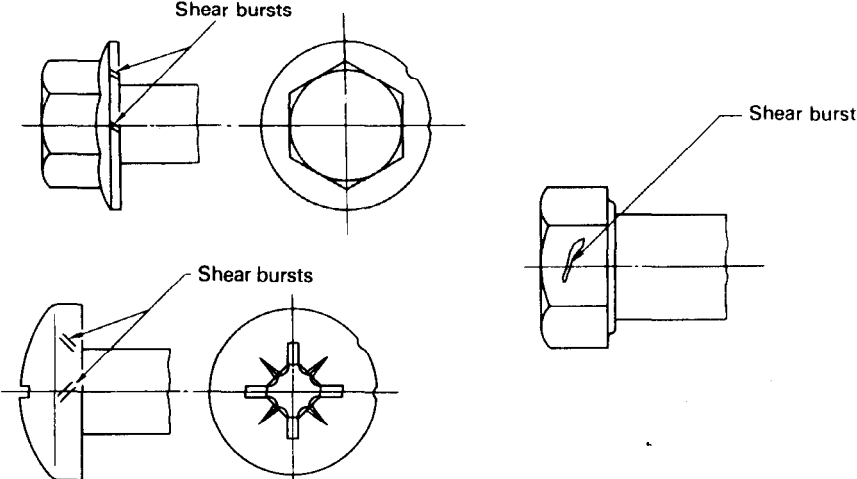
Cause	<p>Shear bursts may occur, for example during forging, frequently at the periphery of products having circular or flanged heads, and are located at approximately 45° to the product axis.</p> <p>Shear bursts may also occur on the sides of hexagon head products.</p>
Appearance	
Limits	<p>Hexagon head screws</p> <p>Shear burst limits on the wrenching head are as follows :</p> <p>Width $< 0,25 \text{ mm} + 0,02s^1)$</p> <p>Depth $< 0,04d$</p> <p>No shear burst in the flats of hexagon bolts and screws shall extend into the crown circle on the top of the head surface (chamfer circle) or into the underhead bearing surface. Shear bursts, occurring at the intersection of two wrenching flats, shall not reduce the width across corners below the specified minimum.</p> <p>Shear bursts in the raised periphery of indented head bolts and screws shall not exceed a width of $0,06d^2)$ or have a depth extending below the indented portion.</p> <p>Circular head screws</p> <p>Flanges of bolts and screws and peripheries of circular head products may have shear bursts, but shall not exceed the following limits :</p> <p>Width of shear bursts :</p> <p>$0,08d_c^3)$ (for only one shear burst);</p> <p>$0,04d_c$ (with two or more forging shear bursts, one of which may extend to $0,08d_c$).</p> <p>1) s = width across flats 2) d = nominal thread diameter 3) d_c = head or flange diameter</p>

3.1.5 Forging cracks in socket head screws

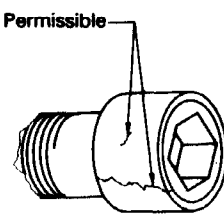
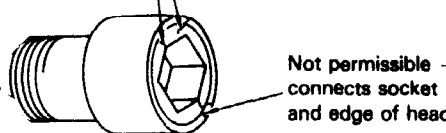
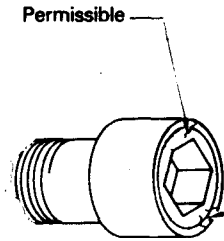
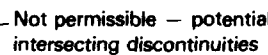
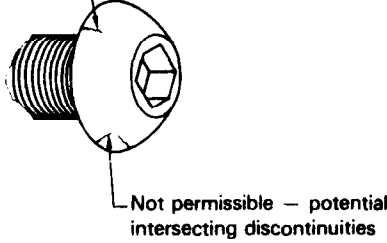
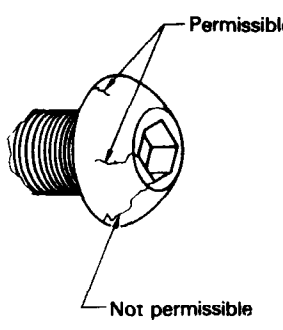
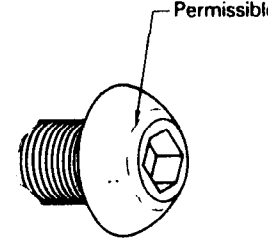
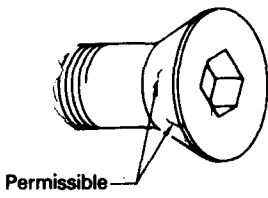
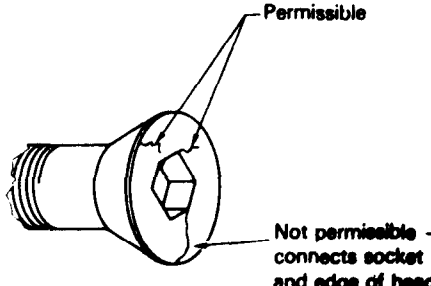
Cause	Cracks in the periphery, in the top surface and on the indented portion (hexagon socket) may occur on the inner and outer faces due to cut-off of wire section, shear and compressive stress during forging operations and countersinking of head.
Appearance	<p style="text-align: center;">Permissible — does not extend more than half the distance between the periphery of the head and the socket</p>         

Appearance
(continued)

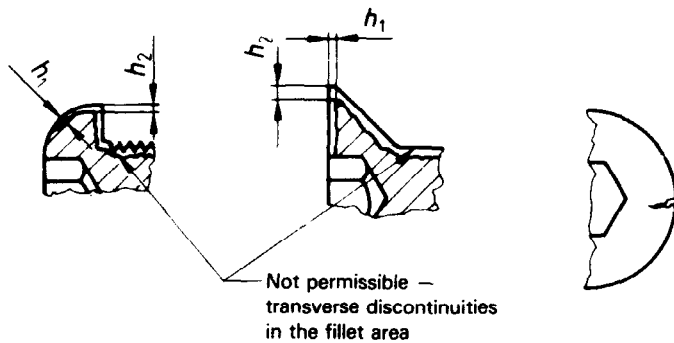
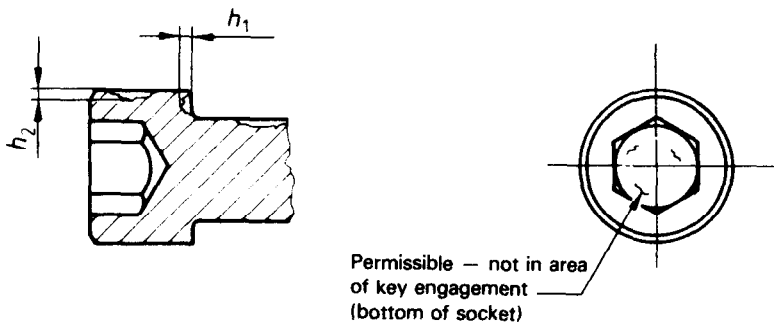
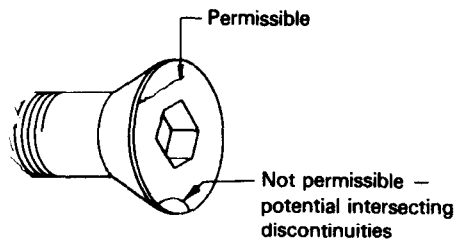

Permissible depths:

$$h_1 < 0,03d_k^{1)} : 0,13 \text{ mm max.}$$

$$h_2 < 0,06d_k : 1,6 \text{ mm max.}$$

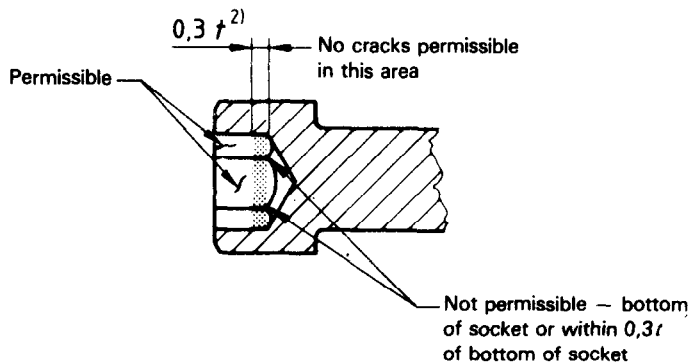

1) d_k = head diameter

2) t = key engagement socket depth

Limits	<p>Cracks extending from the socket to the outer face and cracks with a traverse indicating a potential to intersect are not permissible. Cracks within $0,3r$ of the bottom of the socket are not permissible. Cracks located elsewhere in the socket are permissible, provided that they do not exceed a length of $0,25r$ and a depth of $0,03d_k$ (0,13 mm max.).</p> <p>One crack in the longitudinal direction with a depth not exceeding $0,03d_k$ (0,13 mm max.) at the head/shank intersection and on the top of the head is permissible. Longitudinal cracks with a depth not exceeding $0,06d_k$ (1,6 mm max.) located in the periphery are permissible.</p>
---------------	--

3.2 Raw material seams and laps

A seam or lap is a narrow, generally straight or smooth curved line discontinuity running longitudinally on the thread, shank or head.

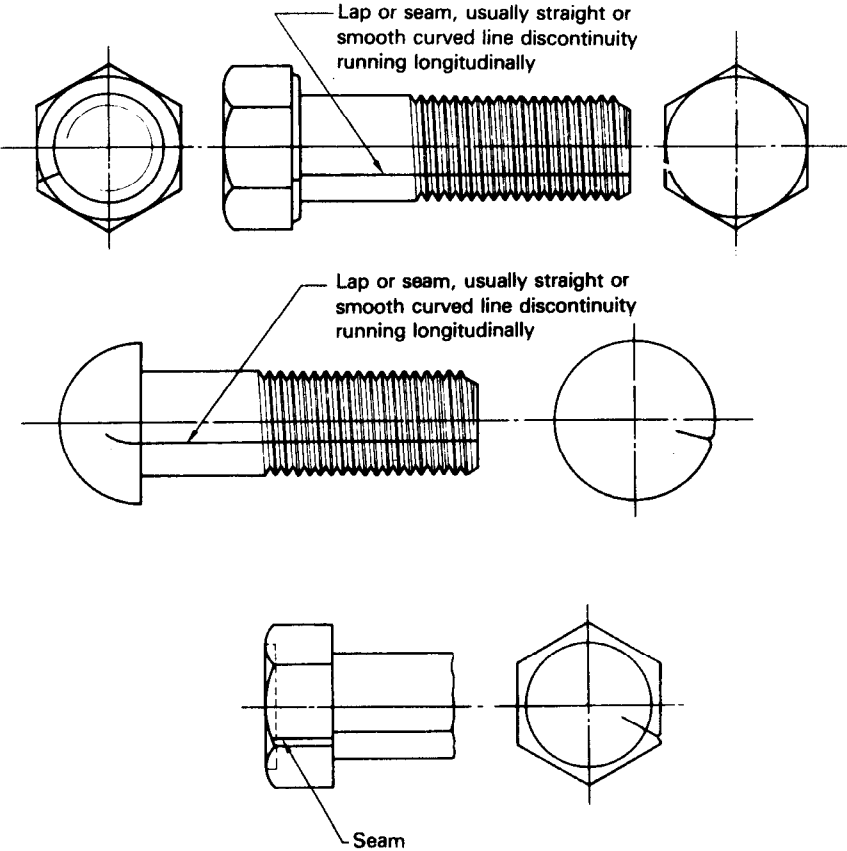
Cause	Seams and laps are inherent in the raw material from which fasteners are made.
Appearance	
Limits	<p>Permissible depth: $0,015d^{(1)} + 0,1$ mm : 0,4 mm max.</p> <p>If laps or seams extend into the head, they shall not exceed the permissible limits for width and depth specified for bursts (see 3.1.3).</p> <p>1) d = nominal thread diameter</p>

3.3 Voids

A void is a shallow pocket or hollow on the surface of a bolt or screw due to non-filling of metal during forging or upsetting.

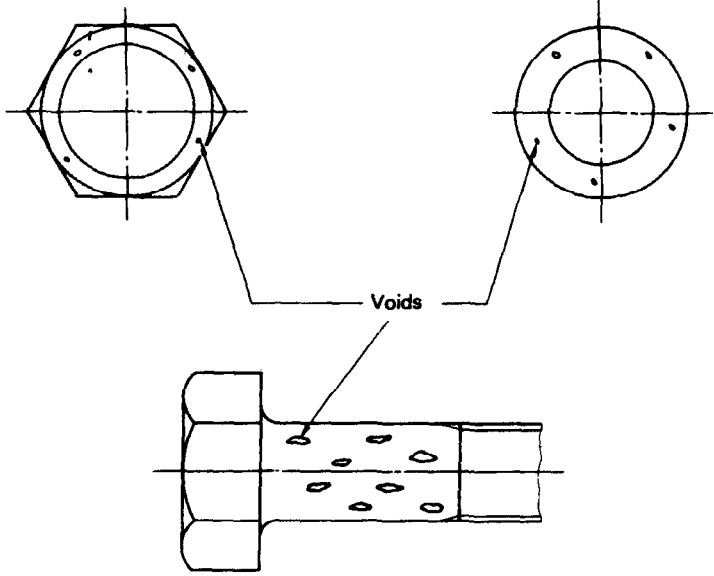
<p>Cause</p>	<p>Voids are produced by marks and impressions due to chips (shear burrs) or by rust formation on the raw material. They are not eliminated during forging or upsetting operations.</p>
<p>Appearance</p>	
<p>Limits</p>	<p>Depth, h, of voids: $h < 0,02d^{1)}$: 0,25 mm max.</p> <p>Area of all voids: The combined surface area of all voids on the bearing face shall not exceed 5 % of the total area.</p> <p>1) d = nominal thread diameter</p>

3.4 Folds

A fold is a doubling over of metal which occurs at the surface of the fastener during forging.

Cause	Folds are produced by material displacements due to lack of congruence of forms and volumes of the single forging steps.
Appearance	<p>Permissible, typical "clover leaf" fold in non-circular shoulder fastener</p> <p>Permissible, at the intersection between flange and driving part</p> <p>Permissible, at the surface of the bolt end</p> <p>Permissible, fold at exterior corner</p> <p>Not permissible, fold at interior corner</p> <p>Not permissible, fold at interior corner</p>
Limits	<p>Folds at interior corners at or below the bearing surface are not permissible, unless specifically permitted in this part of ISO 6157 or in the product standard.</p> <p>Folds at exterior corners are permissible.</p>

3.5 Tool marks

Tool marks are longitudinal or circumferential grooves of shallow depth.

Cause	Tool marks are produced by the movement of manufacturing tools over the surface of the bolt or screw.
Appearance	<p>Tool mark</p> <p>Permissible tool mark from trimming operation</p>
Limits	Tool marks produced by machining in the shank, fillet or bearing surface shall not exceed a surface roughness of $R_a = 3,2 \mu\text{m}$ when tested in accordance with ISO 468.

3.6 Laps on the thread

A lap is a fold-over of metal in the thread. Laps generally show a pattern of consistency between the same product, that is laps will be identically located and with the same direction of traverse between all products.

Cause	Folds and laps on the thread occur during cold-forming of the thread by rolling.	
Appearance	<p>Laps and seams not permissible</p> <p>Load direction</p> <p>0.25H₁</p> <p>Major diameter</p> <p>Pitch diameter</p> <p>Minor diameter</p> <p>Permissible laps and seams</p> <p>0.25H₁</p> <p>Major diameter</p> <p>Pitch diameter</p> <p>Minor diameter</p> <p>Permissible surface irregularities</p> <p>Major diameter</p> <p>Pitch diameter</p> <p>Minor diameter</p> <p>1) H₁ = depth of thread</p>	
Limits	<p>Laps of any depth or length are not permitted in the following places :</p> <ul style="list-style-type: none"> — at the root of the thread; — at the loaded flank of screw thread below the pitch diameter, even if they start beyond the pitch diameter. <p>The following laps are permissible :</p> <ul style="list-style-type: none"> — laps in the crest of the threads of 0,25 H₁ max.; — crest of the threads not entirely rolled out, maximum half a turn on one thread; — laps below the pitch diameter, if they run on the non-loaded flank towards the major diameter and not deeper than 0,25 H₁ and not longer than half a turn on one thread. 	

3.7 Damages

Damages are indentations of any surface of a bolt or screw.

Cause	Damages, for example dents, scrapes, nicks and gouges, are produced by external action during manufacture and handling of bolts and screws, for example during loading.
Appearance	No precise geometrical shape, location or direction, identifiable as external action.
Limits	<p>Damages as described above shall not cause rejection unless it can be shown that they impair function or usability.</p> <p>Dents, scrapes, nicks and gouges on the first three threads shall be such that they allow the screwing on of a go-ring gauge with torque values of 0,001 d³ max., in newton metres.</p> <p>A specific agreement on packaging, for example, may be necessary in order to avoid damage during transport.</p>

Table 1 — Permissible surface discontinuities

Dimensions in millimetres

Clause	3.1.2		3.1.3		3.1.4		3.1.5				3.2	3.3	3.6	3.7	
Defect	Forging cracks		Forging bursts		Shear bursts		Cracks on hexagon socket screws				Laps	Void	Laps in threads	Damages	
Nominal thread diameter, <i>d</i>	Length	Depth and width	Circular and flange heads		Width	Depth	Socket		Head		Raw material	Depth	Depth	Depth	Torque value N · m max.
	max.	max.	Width	Depth			Length	Depth	Faces	Edges (round)	Depth				
			max.	max.	max.	max.	max.	max.	max.	max.	max.	max.	max.	max.	
5	5	0,2	0,08 × head or flange diameter or 0,04 × head or flange diameter	0,2	0,25 mm + 0,02 <i>s</i> for wrenching surfaces 0,08 × head or flange diameter or 0,04 × head or flange diameter	0,2	0,25 × depth of socket	0,13	0,03 × head diameter or 0,13 mm whichever is larger	0,06 × head diameter not more than 1,6 mm	0,17	0,1	0,11	0,125	
6	6	0,24		0,24		0,24		0,13			0,19	0,12	0,14	0,22	
7	7	0,28		0,28		0,28		0,13			0,21	0,14	0,14	0,33	
8	8	0,32		0,32		0,32		0,13			0,22	0,16	0,17	0,51	
10	10	0,4		0,4		0,4		0,13			0,25	0,2	0,2	1	
12	12	0,48		0,48		0,48		0,13			0,28	0,24	0,24	1,73	
14	14	0,56		0,56		0,56		0,13			0,31	0,25	0,27	2,7	
16	16	0,64		0,64		0,64		0,13			0,34	0,25	0,27	4,1	
18	18	0,72		0,72		0,72		0,13			0,37	0,25	0,34	5,8	
20	20	0,8		0,8		0,8		0,13			0,4	0,25	0,34	8	
22	22	0,88		0,88		0,88		0,13			0,4	0,25	0,34	10,6	
24	24	0,96		0,96		0,96		0,13			0,4	0,25	0,41	13,8	
27	27	1,1		1,1		1,1		0,13			0,4	0,25	0,41	19,7	
30	30	1,2		1,2		1,2		0,13			0,4	0,25	0,47	27	
33	33	1,3	1,3	1,3	0,13	0,4	0,25	0,47	35,9						
36	36	1,4	1,4	1,4	0,13	0,4	0,25	0,54	46,6						
39	39	1,6	1,6	1,6	0,13	0,4	0,25	0,54	59,3						

4 Inspection and evaluation procedure

For the acceptance inspection procedure, see ISO 3269. Surface coatings shall be removed before examination if identification of the surface discontinuities is impaired.

NOTE — The 1984 edition of ISO 3269 gives no specifications on sampling plans for surface discontinuities of fasteners. Until this has been completed, the applicable sampling plan is given in the annex.

4.1 Principles

The manufacturer is entitled to use any inspection procedures but due care shall be taken to ensure that products conform to this part of ISO 6157.

The purchaser may use the inspection procedure specified in this clause at his acceptance inspection in order to decide whether a lot of fasteners may be accepted or rejected. This procedure shall also be applied when conformance to specification is disputed, unless some other acceptance procedure has been agreed between the manufacturer and the purchaser at the time of ordering the fasteners.

4.2 Non-destructive testing

A random sample shall be taken from the lot in accordance with table 2 in the annex and subjected to either visual tests or other

suitable tests, e.g. magnetic techniques or eddy current. If no defective product is found the lot shall be accepted (see also 4.4). If defective products are found these shall form the lot size for the procedures given in 4.3.

4.3 Destructive testing

If defective products are detected by the procedures given in 4.2, then a secondary sample shall be taken from the defective products, in accordance with table 3 in the annex, consisting of the products indicating the most serious defects and sectioned at 90° through the discontinuity where the greatest depth is expected.

4.4 Evaluation

If on visual inspection any product is found with quench cracks in any location, or folds at interior corners or below the bearing surface, except "clover leaf" folds in non-circular shoulder fasteners, the lot shall be subject to rejection.

If on the destructive test any product is found with forging cracks, bursts, seams and laps, voids, tool marks or damages which exceed the allowable limits as specified for the applicable type of discontinuity, the lot shall be subject to rejection.

Annex

Sampling plan for surface discontinuities

(This annex forms an integral part of this standard.)

Sampling for surface discontinuities shall be carried out using the sample sizes given in table 2 and using the principles and procedures given in clause 4.

Table 2 — Sample sizes for visual and non-destructive testing

Lot size ¹⁾ <i>N</i>	Sample size <i>n</i>
$N < 1\ 200$	20
$1\ 201 < N < 10\ 000$	32
$10\ 001 < N < 35\ 000$	50
$35\ 001 < N < 150\ 000$	80

1) Lot size is the number of products of the same type, size and property class submitted for inspection at one time.

NOTE — The sample sizes are based on special inspection level S-4 specified in ISO 2859.

Table 3 — Secondary sample sizes for destructive testing

Number of defective products in the sample <i>N</i>	Secondary sample size <i>n</i>
$N < 8$	2
$9 < N < 15$	3
$16 < N < 25$	5
$26 < N < 50$	8
$51 < N < 80$	13

NOTE — The secondary sample sizes are based on general inspection level II specified in ISO 2859.

Bureau of Indian Standards

BIS is a statutory institution established under the *Bureau of Indian Standards Act, 1986* to promote harmonious development of the activities of standardization, marking and quality certification of goods and attending to connected matters in the country.

Copyright

BIS has the copyright of all its publications. No part of these publications may be reproduced in any form without the prior permission in writing of BIS. This does not preclude the free use, in the course of implementing the standard, of necessary details, such as symbols and sizes, type or grade designations. Enquiries relating to copyright be addressed to the Director (Publication), BIS.

Review of Indian Standards

Amendments are issued to standards as the need arises on the basis of comments. Standards are also reviewed periodically; a standard along with amendments is reaffirmed when such review indicates that no changes are needed; if the review indicates that changes are needed, it is taken up for revision. Users of Indian Standards should ascertain that they are in possession of the latest amendments or edition by referring to the latest issue of 'BIS Handbook' and 'Standards Monthly Additions'

This Indian Standard has been developed from Doc: No. LM 14 (0193)

Amendments Issued Since Publication

Amend No.	Date of Issue	Text Affected

BUREAU OF INDIAN STANDARDS

Headquarters:

Manak Bhavan, 9 Bahadur Shah Zafar Marg, New Delhi 110002
Telephones: 323 01 31, 323 33 75, 323 94 02

Telegrams: Manaksanstha
(Common to all offices)

Regional Offices:

Central : Manak Bhavan, 9 Bahadur Shah Zafar Marg
NEW DELHI 110002

Telephone
323 76 17, 323 38 41

Eastern : 1/14 C.I.T. Scheme VII M, V.I.P. Road, Maniktola
CALCUTTA 700054

{ 337 84 99, 337 85 61
{ 337 86 26, 337 91 20

Northern : SCO 335-336, Sector 34-A, CHANDIGARH 160022

{ 60 38 43
{ 60 20 25

Southern : C.I.T. Campus, IV Cross Road, CHENNAI 600113

{ 235 02 16, 235 04 42
{ 235 15 19, 235 23 15

Western : Manakalaya, E9 MIDC, Marol, Andheri (East)
MUMBAI 400093

{ 832 92 95, 832 78 58
{ 832 78 91, 832 78 92

Branches : AHMADABAD. BANGALORE. BHOPAL. BHUBANESHWAR.
COIMBATORE. FARIDABAD. GHAZIABAD. GUWAHATI.
HYDERABAD. JAIPUR. KANPUR. LUCKNOW. NAGPUR.
PATNA PUNE. THIRUVANANTHAPURAM.