

भारतीय मानक

कंक्रीट और चिनाई बांधों के लिए विस्थापन मापन युक्तियों के
संस्थापन, अनुरक्षण और अवलोकन की रीति संहिता

भाग 2 भूगणितीय अवलोकन – शिखर संधान

Indian Standard

CODE OF PRACTICE FOR INSTALLATION,
MAINTENANCE AND OBSERVATION OF
DISPLACEMENT MEASURING DEVICES FOR
CONCRETE AND MASONRY DAMS

PART 2 GEODETIC OBSERVATION — CREST COLLIMATION

ICS 93.160

© BIS 2000

BUREAU OF INDIAN STANDARDS
MANAK BHAVAN, 9 BAHADUR SHAH ZAFAR MARG
NEW DELHI 110002

FOREWORD

This Indian Standard was adopted by the Bureau of Indian Standards, after the draft finalized by the Hydraulic Structures Instrumentation Sectional Committee, had been approved by the Water Resources Division Council.

Measurements of relative horizontal displacements of points in the interior of a dam provide the fastest, simplest and direct method of watching the structural behaviour of the dam. Measurements of structural deformation over a considerable period of time (several years) furnishes information regarding the general elastic behaviour of the entire structure and foundation and provide a means for determining the elastic shape of the deflected structure which will permit distinction of load and thermal deflection components and with precise alignment data, provide for estimating the amount of translation or sliding.

Deflection cycles of remarkable uniformity in amplitude and period become clearly evident from the initiation of observations if any deviation is apparent. Study of this deviation helps in detecting development of distress conditions in structure or foundation.

Depending upon the amount and type of related and supporting information available, observations of crest collimation movable target can be used for ascertaining the elastic and inelastic physical properties of the concrete or masonry and foundation rocks.

Relative displacements are measured by means of collimators and by the use of plumb lines with pendulums placed inside a shaft in the dam. The displacement of the wire is measured normal to and parallel to dam axis in straight gravity dams (radial and tangential direction in case of arch dams) with respect to fixed points in the shaft.

Though the measurement of displacement by pendulums is restricted to significant individual points or change of direction of significant lines, pendulums are the foremost instruments for the observation of behaviour of dam.

In this type of observation of displacement measuring device, a line of sight is established across the dam with a theodolite on one bank and a fixed target on the opposite bank. Movable target stations are fixed on the crest of the dam in this line of sight. The observations are made at both theodolite and movable target stations by keeping the line of sight remaining fixed.

This standard has been prepared in two parts : IS 13073 (Part 1) : 1991 'Code of practice for installation, maintenance and observation of displacement measuring devices in concrete and masonry dams : Part 1 Deflection measurement using plumb lines', and Part 2 covers measurement by means of collimators'.

For choice and location of instruments in masonry and concrete dams, reference is invited to IS 7436 (Part 2) : 1997 'Guide for types of measurement for structures in river valley projects and criteria for choice and location of measuring instruments : Part 2 Concrete and masonry dams (*first revision*)'.

For the purpose of deciding whether a particular requirement of this standard is complied with, the final value, observed or calculated, expressing the result of a test or analysis, shall be rounded off in accordance with IS 2 : 1960 'Rules for rounding off numerical values (*revised*)'. The number of significant places retained in the rounded off value should be the same as that of the specified value in this standard.

Indian Standard

CODE OF PRACTICE FOR INSTALLATION, MAINTENANCE AND OBSERVATION OF DISPLACEMENT MEASURING DEVICES FOR CONCRETE AND MASONRY DAMS

PART 2 GEODETIC OBSERVATION — CREST COLLIMATION

1 SCOPE

This standard (Part 2) lays down the details for the installation, maintenance and observation of crest collimation movable target for measurement of horizontal movement of points on the crest of concrete or masonry dam.

2 PRINCIPLE AND CONSTRUCTION

A line of sight should be established across the dam with a theodolite on one bank and a fixed target on the opposite bank. In this line of sight, movable target stations should be fixed on the crest of the dam. The observations should be made at both theodolite and movable target stations. The line of sight remains fixed. The movable target should be moved and brought to the line of sight with the aid of a rotating screw. The position of the mobile target should be read by means of a micrometer attachment on the mobile target. Difference of the observed value of the mobile target position from the initial reading gives the displacement at the crest of the dam. The displacement should be measured normal to dam axis in straight gravity dams and radial in case of arch dams with respect to fixed line of sight.

3 EQUIPMENT

3.1 The various components that constitute the fixed line of sight and equipment for observation of displacement at crest of the dam are as under.

3.2 Fixed Line of Sight

3.2.1 Theodolite Station

Theodolite station should be constructed with reinforced cement concrete (see Fig.1). The vertical reinforcement of the pillar should be fixed below the ground level for fixity.

On top of the pillar, forced centering device suitable for fixing the theodolite should be embedded. The forced centering device vary with the theodolite and may be procured from the manufacturer. The detailed instructions given by the manufacturer for erecting the force centering device should be followed. In place

of a particular forced centering device, a steel plate having necessary grooves for convenient fixing of different types of theodolites can also be used. Suitable protective covers with locking arrangements (similar to those shown in Fig. 1) should also be provided on top of the pillar. For safety of the pillar, around fencing should be recommended.

3.2.2 Fixed Target Station

On the opposite bank and in the line of sight a fixed target station should be provided. The fixed target may either be fixed type or mounting type as given in 3.2.2.2.

3.2.2.1 Fixed type target

A stainless steel rod of diameter 25 mm and length not less than 150 mm should be used for this purpose. A hole should be drilled in the rock and this bull's eye type target should be cement grouted as shown in Fig. 2. At outer face two concentric circles should be engraved. The centre circle and the outer ring should be painted white and the middle ring should be painted black.

3.2.2.2 Mounting type target

A needle type target made of brass as shown in (Fig. 3) should be used as a fixed target for establishing the line of sight. In this case the needle target should be fixed on top of a concrete pillar in a similar way as explained in 3.2.1. Suitable groove at the centre of the forced centering plate should be provided for fixing the needle target. Care should be taken to ensure that the same needle target is always used and the position is not changed. A shade made out of M.S. plate and painted black as shown in Fig. 4 may be fixed on the rear side of the needle target for sharp pointing of the target from theodolite.

Mounting type targets supplied by theodolite manufacturers may also be used as fixed targets. This target should have white and black wedges on its vertical face with foot screws at the base and may be levelled. The same target should be used as fixed target, as far as possible.

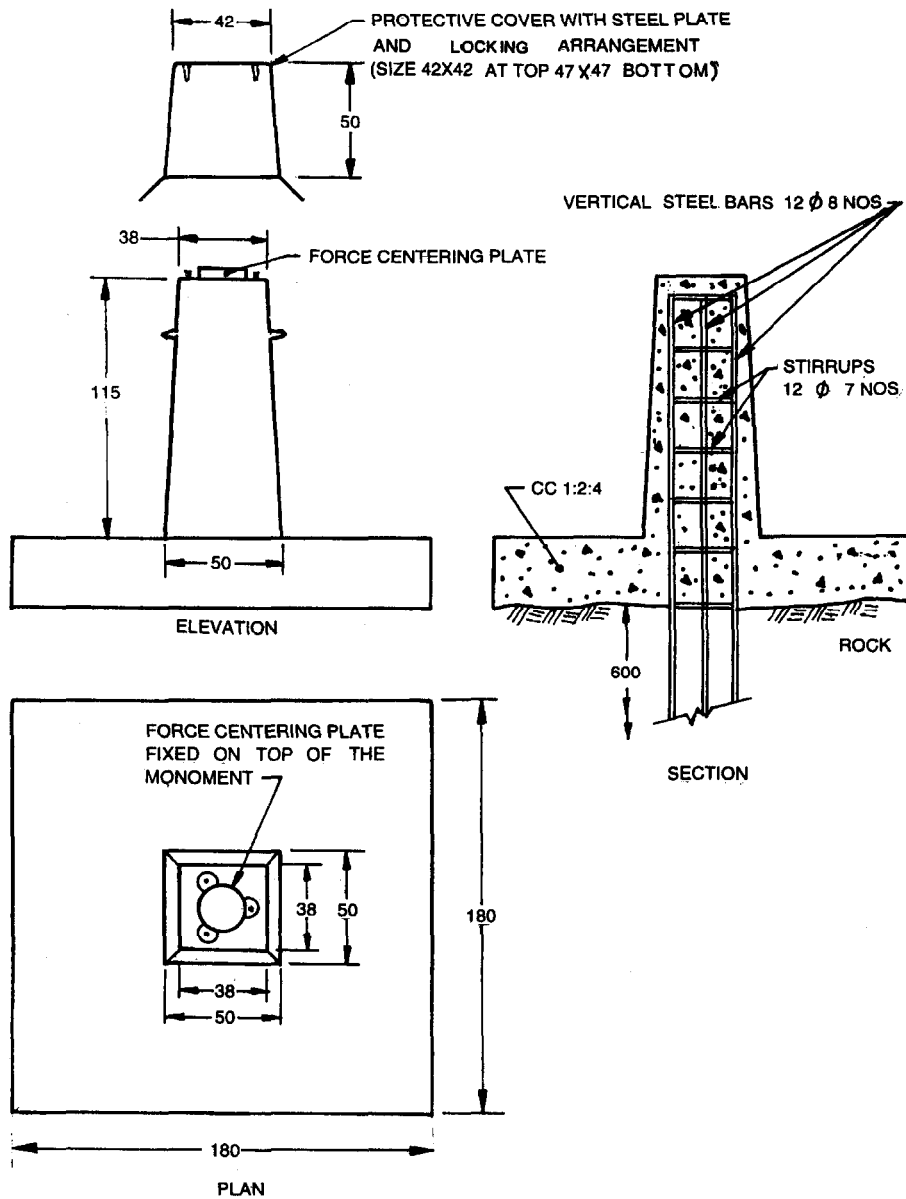

All dimensions in millimetres.

FIG. 1 DETAIL OF INSTRUMENT STATION

3.3 Displacement Measuring

3.3.1 Mobile Target

Mobile target as shown in Fig.5 should be fixed on top of a base during observation. The base for taking this mobile target should be embedded on top of dam crest in the line of sight. The base is fixed at a lower level than the road level and should be covered with suitable M.S. Plate with nuts and bolts or with suitable locking arrangements.

4 INSTALLATION

4.1 Theodolite and Fixed Target Stations

Before fixing the sites for theodolite and fixed target stations, the displacement measuring points on top

of the dam should be finalized. For straight gravity dam, the points on the dam may lie in a straight line, so that with one theodolite station and one fixed target station, the displacement of all the points may be observed (see Fig. 6). For arch dam one theodolite station and one fixed target station are essentially required for one mobile target station (see Fig. 7). When mobile target stations are located on top of a dam block, in which pendulums are installed, observations on the collimation may be correlated to the observation on the dam pendulums.

The stations should be constructed on a firm ground. M 15 mix may be used for concrete works. Care should be taken to see that the forced centering device is fixed firmly on top of the concrete pillar. The detailed

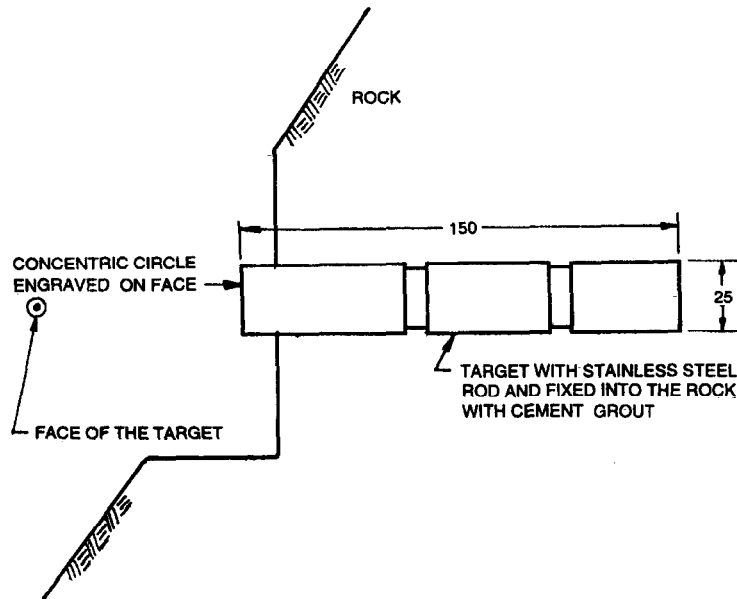

All dimensions in millimetres.
FIG. 2 FIXED TYPE TARGET

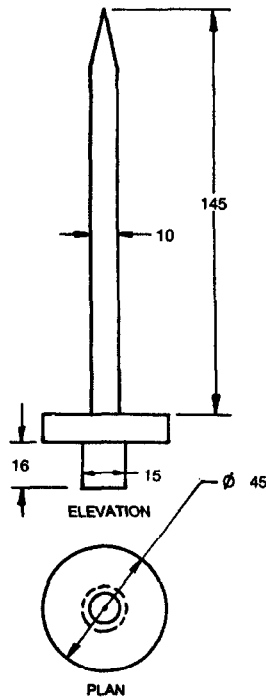

All dimensions in millimetres.
FIG. 3 DETAIL OF NEEDLE TARGET

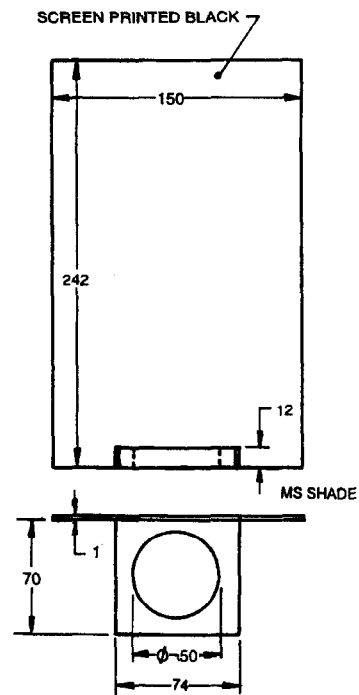

All dimensions in millimetres.
FIG. 4 DETAIL OF SHADE

instructions given by the manufacturer for fixing the force centering device should be followed.

4.2 Mobile Target Station

For embedding the base of mobile target, the surface

should be cut and chiselled. The centre bolt of the base should be cement grouted carefully. The base should be embedded at suitable depth from dam top level, so that the scale reading on the mobile target may be made easily.

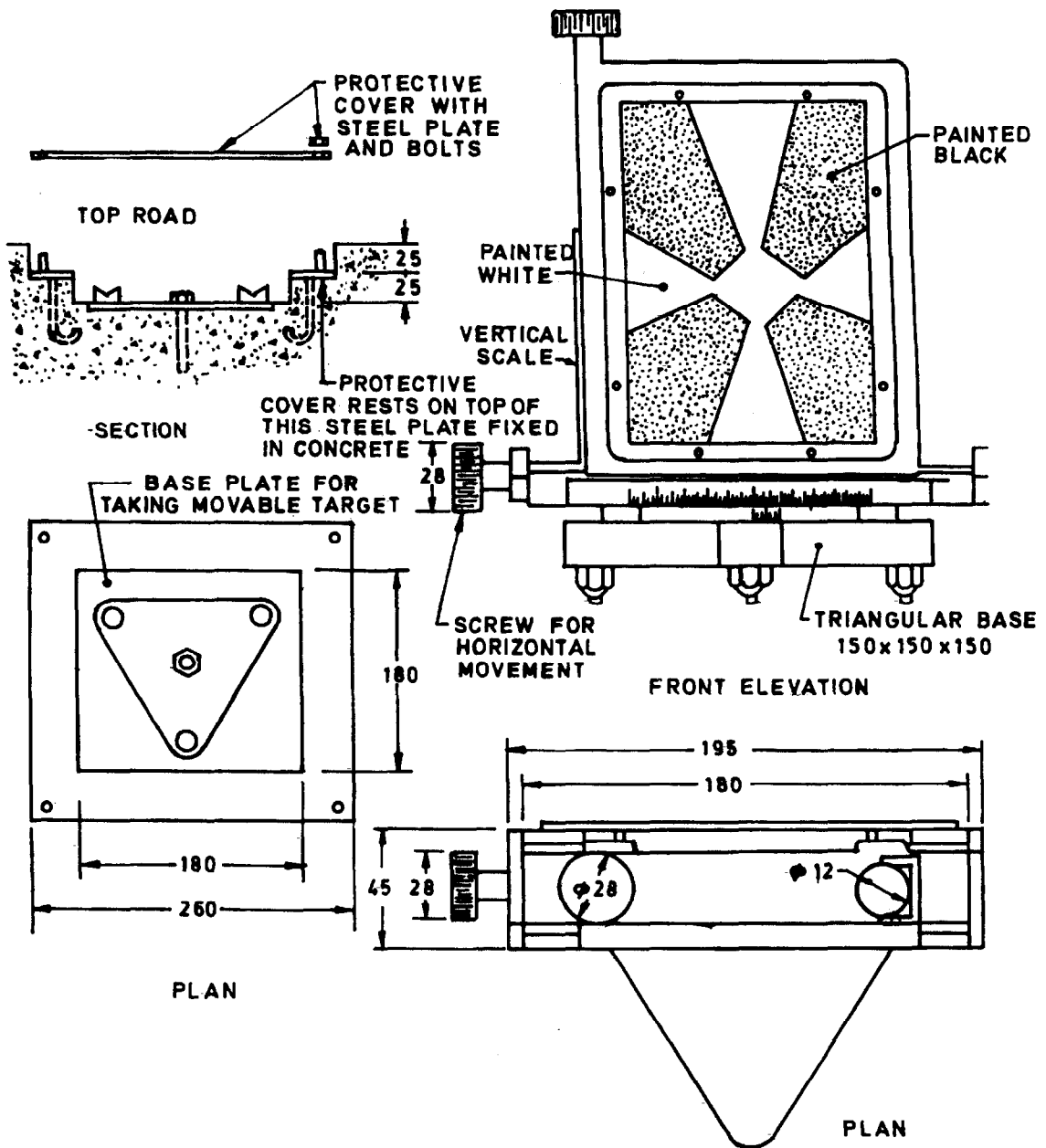

All dimensions in millimetres.
 FIG. 5 DETAILS OF MOVABLE TARGET

5 OBSERVATIONS

5.1 The observations are taken in the following steps:

- 1) Theodolite should be set on the fixed centering device of the station. The same theodolite should be set up over the station at all times as far as possible. The relative position of the footscrews on the trivet should be kept constant. The instrument should be levelled very accurately. A sighting should be made to the fixed target on the opposite bank in clamp left position of the instrument, that is, on one face of the instrument.
- 2) A mobile target should be fixed on top of the mobile target station. The face of the mobile target should be fixed so that it is perpendicular to the line of sight. This may be done by bringing the rotating drums as shown in Fig. 8 (on top of which the mobile target has been fixed) to a fixed bearing.

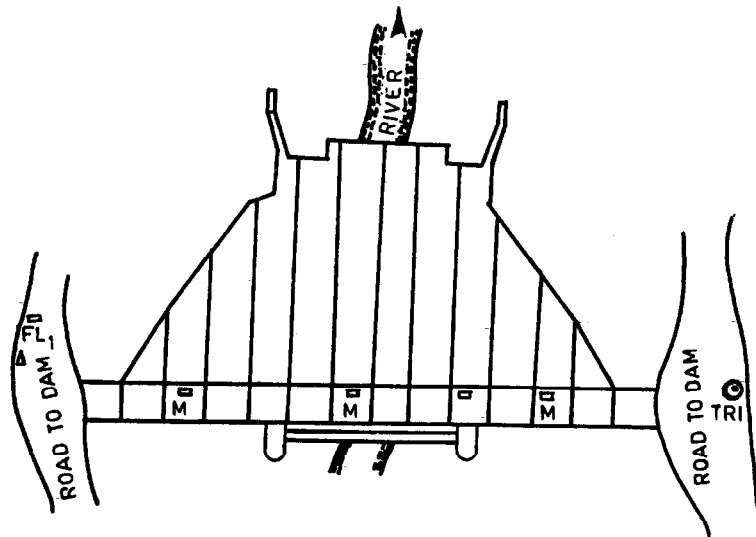

LEGEND

- ⊙ INSTRUMENT STATIONS
- △ FIXED TARGET STATIONS
- MOBILE TARGET STATIONS

FIG. 6 LOCATION OF MOBILE TARGETS

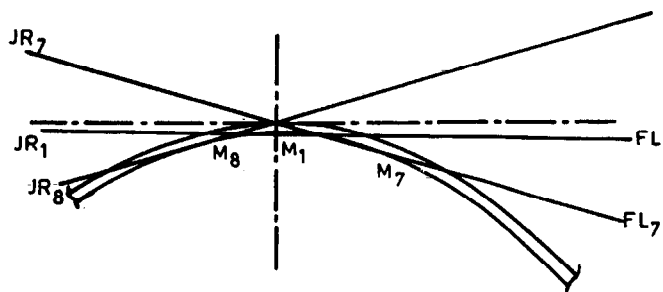

LEGEND

- M 1
 - M 7
 - M 8
 - FL 1
 - FL 7
 - FL 8
 - JR 1
 - JR 7
 - JR 8
- MOBILE TAGE T STATIONS
- FIXED TAGE T STATIONS
- INSTRUMENT STATIONS

FIG. 7 STATIONS LOCATION

- 3) Mobile target party should be contacted by a two-way radio or by signalling a flag from the instrument station. Mobile target may be sighted by lowering the telescope and focusing the mobile target correctly. The man at the mobile target station may be directed to move the mobile target by turning the horizontal motion screw into the line of sight from the apparent right by using the two-way radio or by flag signal target in coincidence with the line of sight should be indicated.
- 4) The micrometer reading of the mobile target should be recorded at the target location.
- 5) The mobile target should then be moved and

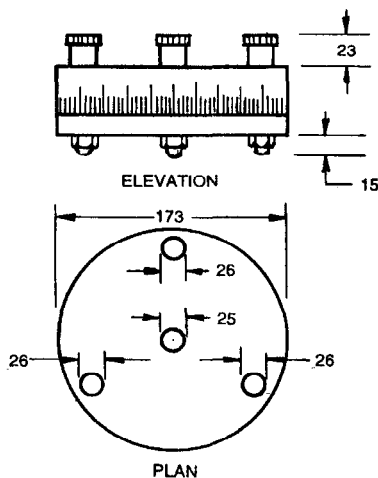

All dimensions in millimetres.
FIG. 8 ROTATING DRUM

repeated. Four readings from the apparent right should be taken and averaged.

- 6) The face of the theodolite should be changed, fixed target may be sighted and then the mobile target, should be brought into coincidence with the line of sight by moving the mobile target from apparent left. The mobile target should be moved and then brought to line of sight. Four readings should be taken and averaged.

5.2 Checking of the Readings

The difference between the average of the two sets of readings should be calculated. This should be within

a tolerance limit. The tolerance limit should be calculated from the formula $d \times 6.72 \times 10^{-6}$ instrument station to mobile target station in the same units of the readings. If the allowable tolerance is not met, the whole process of observation should be repeated, till the desired accuracy is obtained.

6 DATA PRESENTATION

The mean of the two average readings should be calculated. This data should be recorded in a printed form, which should be designed to suit the measuring target. The same should be got printed sufficiently in advance at the time of commencement of the observations.

7 FREQUENCY OF OBSERVATIONS

Weekly observations should be made during the first filling of the reservoir after which fortnightly schedule of reading may be adopted. More frequency schedule of reading may be adopted when rate of reservoir rise is fast. At least one reading should be obtained for the highest and the lowest reservoir levels attained every year.

8 ANALYSIS OF DATA

Magnitude of dam displacement at crest level should be obtained by subtracting the initial reading. Displacement values so computed should be plotted to show the deflected shape of dam at crest level. Continuous plots of deflection at various observation times, with corresponding reservoir level against time should be maintained for watching the deflection trend and behaviour of the dam. This should also be correlated with the observation on the dam pendulums.

Bureau of Indian Standards

BIS is a statutory institution established under the *Bureau of Indian Standards Act, 1986* to promote harmonious development of the activities of standardization, marking and quality certification of goods and attending to connected matters in the country.

Copyright

BIS has the copyright of all its publications. No part of these publications may be reproduced in any form without the prior permission in writing of BIS. This does not preclude the free use, in the course of implementing the standard, of necessary details, such as symbols and sizes, type or grade designations. Enquiries relating to copyright be addressed to the Director (Publications), BIS.

Review of Indian Standards

Amendments are issued to standards as the need arises on the basis of comments. Standards are also reviewed periodically; a standard along with amendments is reaffirmed when such review indicates that no changes are needed; if the review indicates that changes are needed, it is taken up for revision. Users of Indian Standards should ascertain that they are in possession of the latest amendments or edition by referring to the latest issue of 'BIS Handbook' and 'Standards : Monthly Additions'.

This Indian Standard has been developed from Doc : No. WRD 16 (182).

Amendments Issued Since Publication

Amend No.	Date of Issue	Text Affected

BUREAU OF INDIAN STANDARDS

Headquarters:

Manak Bhavan, 9 Bahadur Shah Zafar Marg, New Delhi 110002
Telephones : 323 01 31, 323 94 02, 323 33 75

Telegrams: Manaksansth:
(Common to
all offices)

Regional Offices:

Central : Manak Bhavan, 9 Bahadur Shah Zafar Marg
NEW DELHI 110002

Telephone

{ 323 76 17
323 38 41

Eastern : 1/14 C. I. T. Scheme VII M, V. I. P. Road, Maniktola
CALCUTTA 700054

{ 337 84 99, 337 85 61
337 86 26, 337 86 62

Northern : SCO 335-336, Sector 34-A, CHANDIGARH 160022

{ 60 38 43
60 20 25

Southern : C. I. T. Campus, IV Cross Road, CHENNAI 600113

{ 235 02 16, 235 04 42
235 15 19, 235 23 15

Western : Manakalaya, E9 MIDC, Marol, Andheri (East)
MUMBAI 400093

{ 832 92 95, 832 78 58
832 78 91, 832 78 92

Branches : AHMADABAD. BANGALORE. BHOPAL. BHUBANESHWAR.
COIMBATORE. FARIDABAD. GHAZIABAD. GUWAHATI. HYDERABAD. JAIPUR.
KANPUR. LUCKNOW. NAGPUR. PATNA. PUNE. THIRUVANANTHAPURAM.