

भारतीय मानक  
माप विज्ञान — लम्बाई मापन उपकरण  
भाग 2 इस्पात का मापन टेप

*Indian Standard*  
LEGAL METROLOGY — MATERIAL MEASURES OF  
LENGTH  
PART 2 STEEL TAPE MEASURES

ICS17.040.30

© BIS 1997

**BUREAU OF INDIAN STANDARDS**  
MANAK BHAVAN, 9 BAHADUR SHAH ZAFAR MARG  
NEW DELHI 110002

## FOREWORD

This Indian Standard (Part 2) was adopted by the Bureau of Indian Standards after the draft finalized by the Commercial Weights and Measures Sectional Committee had been approved by the Light Mechanical Engineering Division Council.

This standard was first published as IS 1270:1959 'Specification for metric, steel tape measures (winding) type' and was subsequently revised in 1965.

This standard was first published in 1964 and covered metric woven, metallic and glass fibre tape measures; whereas steel tape measures were covered in IS 1270 : 1959 'Specification for metric, steel tape measures (winding) type' (subsequently revised in 1965). This revision has been brought out to merge the two standards and to publish IS 1269 in two parts as follows:

Part 1 Woven metallic and glass fibre tape measures, and

Part 2 Steel tape measures.

After the publication of this standard, IS 1270:1965 'Specification for metric, steel tape measures (winding) type' will be withdrawn.

This revision is based on the suggestions received from the Directorate of weights and Measures as a result of practical application of the standard, more so as the *Standards of Weights and Measures Act* was revised in 1976. The contents of this standard have also been harmonized with OIML Recommendation OIML R-35 : 1977 'Material measures of length for general use' issued by International Organization of Legal Metrology, France. As a result of this harmonization, the following modifications have been introduced:

- i) The definitions/terminology used in Legal Metrology have been included.
- ii) The tape lengths covered in this standard are extended upto 200 meters nominal length. Tapes for 0.5 m, 1.5 m, 3 m, 4 m and 5 m denomination are included, considering the maximum use of these tapes by the common consumer required for measurements in day-to-day applications.
- iii) The material and construction of the tapes are defined in detail alongwith methods of testing and checking.
- iv) The graduation scale marking pattern on the tapes has been revised, to give more clarity and to avoid any confusion while taking actual measurements. Marking clause has also been revised.
- v) The values of maximum permissible errors for graduation marking on tapes are redefined and based on the permissible errors; classification has been made into three accuracy classes.

For the purpose of deciding whether a particular requirement of this standard is complied with, the final value, observed or calculated, expressing the result of a test, shall be rounded off in accordance with IS 2 : 1960 'Rules for rounding off numerical values (*revised*)'. The number of significant places retained in the rounded off value should be the same as that of the specified value in this standard.

*Indian Standard***LEGAL METROLOGY — MATERIAL MEASURES OF LENGTH****PART 2 STEEL TAPE MEASURES****1 SCOPE**

1.1 This Indian Standard ( Part 2 ) covers the requirements for steel tape measures which are used for measurements where the use of rigid length measures is not convenient or practicable.

**2 TERMINOLOGY**

For the purpose of this standard, following definitions/terminologies shall apply.

**2.1 Material measures of length**

The length measures covered by this standard are material measures with scale marks, the distances between which are indicated in legal units of length.

**2.1.1 Nominal length**

The nominal length of a length measure is the total value of the material length of that measure, and by which it is designated.

**2.1.2 Principal Scale Marks**

The principal scale marks are the two marks, the distance between which represents the nominal length of the measure under reference condition.

**2.2 Types of Measures****2.2.1 End Measure**

An end measure is one that has principal scale marks corresponding to the two end surfaces or edges of the measure.

**2.2.2 Line Measure**

A line measure is one that has principal scale marks represented by two lines, holes, or marks.

**2.2.3 Composite Measure**

A composite measure is one that has principal scale marks which are, respectively, an end surface or edge and a line, hole or mark.

**2.3 Supplementary Devices**

Supplementary devices for length measure, such as one or more fixed or movable hooks, rings, handles, tips, winding devices and verniers, are intended to facilitate and extend the utility of the measure.

**3 NOMINAL LENGTH**

3.1 The steel tape measures shall be made in nominal lengths of 0.5 m, 1m, 2m, 3m, 4m or 5 m or an integral multiple of 5 m provided that the maximum nominal length shall not exceed 200 m.

NOTE — The nominal length of a steel tape measure is the distance at the reference temperature, between the initial and terminal graduation lines, when the tape measure is stretched, without friction, on a horizontal plane surface, under a tension of 50 Newtons. The length so measured shall be equal within the limits of maximum permissible errors, to the nominal length of the tape measure.

**4 MATERIAL**

4.1 Length measure and the supplementary devices shall be made from suitable steels or stainless steel which are sufficiently durable, stable and resistant to environmental influences under normal conditions of use.

4.2 During normal use at temperature not deviating by more than 8°C above or below the reference temperature, variations in length shall not exceed the maximum permissible errors.

4.2.1 For measures to be used under a specified tension, a variation of  $\pm 10$  percent in tension shall not produce a variation in length exceeding the maximum permissible error.

**5 CONSTRUCTION**

5.1 Length measures and their supplementary devices shall be robustly constructed and well finished (see Fig. 1 to 5).

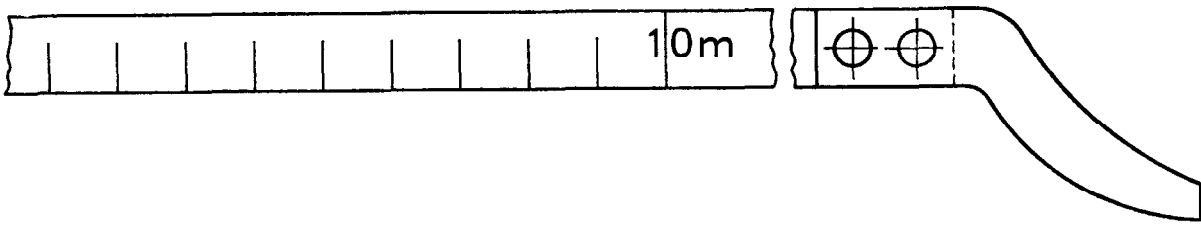

FIG. 1 END OF MEASURE

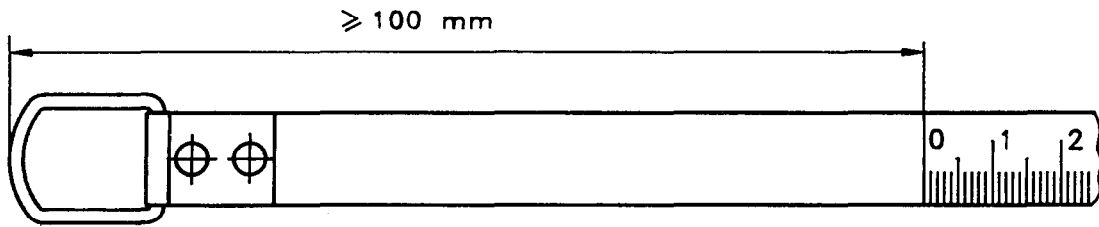

FIG. 2 MEASURE WITH ZERO AWAY FROM RING

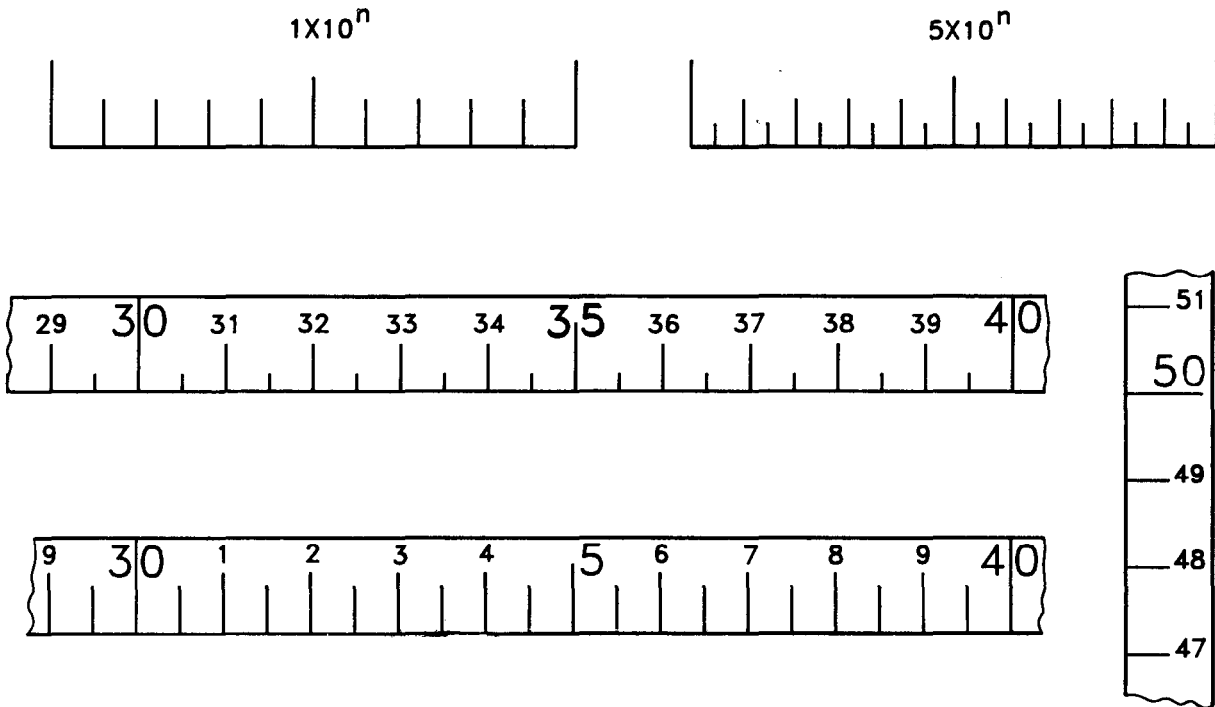

FIG. 3 GRADUATION LINES AND NUMBERING

5.2 The cross section of the length measure shall be such that under nominal conditions of use, measurements can be made with the degree of accuracy required for the accuracy class, to which the measure in question belongs.

NOTE — It is recommended for guidance of manufacturers and users that length measures may have a width of not less than 5 mm and a maximum thickness of 0.4 mm.

5.3 The steel tape measure shall be so made that when it is stretched on a plane surface, the edges are practically straight and parallel.

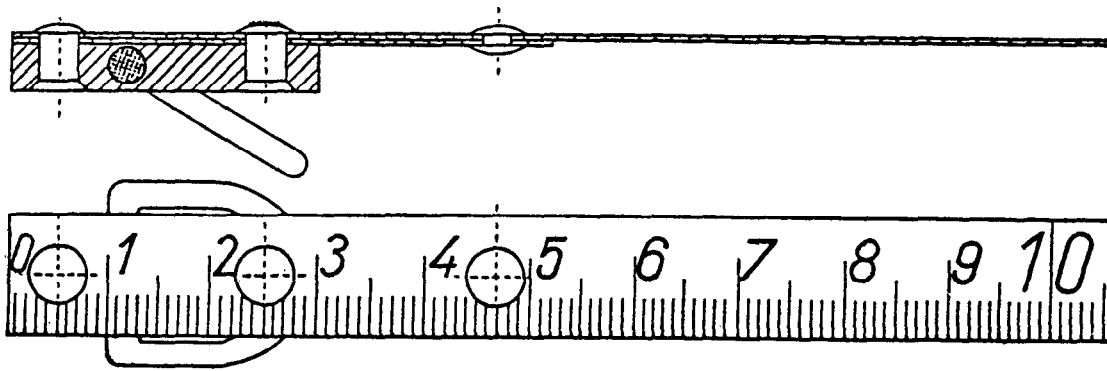

FIG. 4 MEASURE COMMENCING WITH ZERO

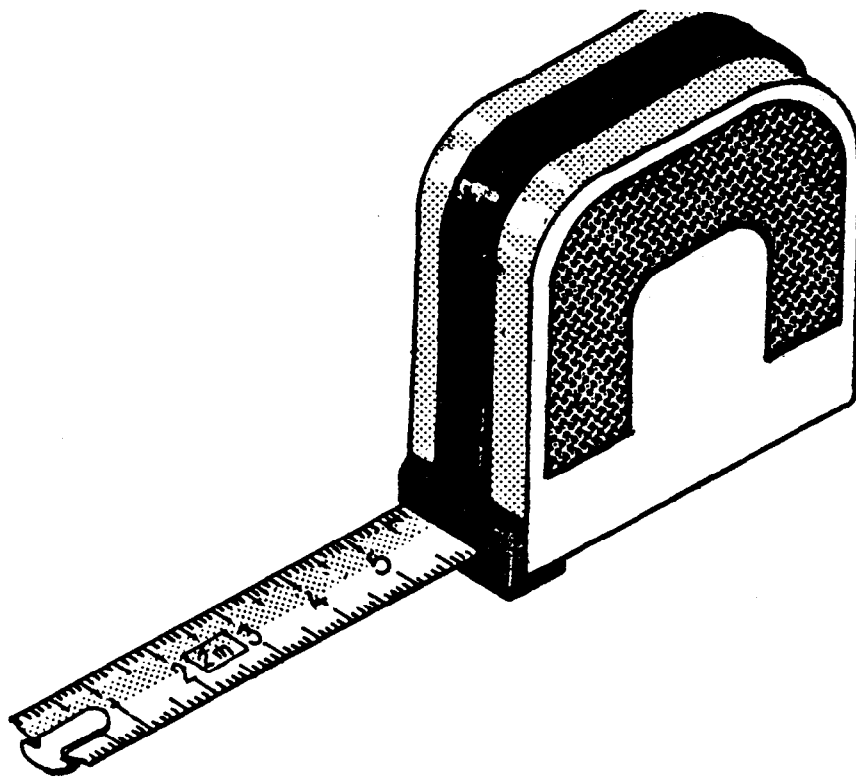

FIG. 5 LONG MEASURE OF STEEL AND CONTAINER

5.4 The surfaces forming the two principal scale marks ( end surfaces ) of end measures shall be flat. These end surfaces and the lines shall be perpendicular to the longitudinal axis of the measure.

5.5 All the zero end tape measures shall be provided, with a ring or other device for facilitating withdrawal. The ring or other device, when provided shall be fastened to the tape measure by a metal strip of the same width as the tape (see Fig. 2 and 5).

5.6 The winding tape measure shall be capable of

being wound into suitable container or other winding device of robust construction and made of metal, plastic, leather or other suitable material (see Fig. 5).

5.7 The winding devices shall be so designed that they do not cause any inaccuracy or permanent deformation in the tape.

5.8 The edges of tape measures shall be slightly rounded.

5.9 The tape measure shall be provided with a rust proof coating and shall be free from burrs.

## 6 GRADUATIONS

6.1 Graduated scales shall be clear, regular, indelible, and carried out in such a way that reading is definite, easy and unambiguous (see Fig. 3).

6.2 The value of the scale division shall take the form  $1 \times 10^n$ ,  $2 \times 10^n$  or  $5 \times 10^n$  metres where the exponent 'n' is a positive or negative whole number or zero.

The value of the scale division shall not exceed:

- 1 cm for measures with a nominal length not greater than 2 m,
- 10 cm if the nominal length is greater than 2 m and less than 10 m,
- 20 cm if the nominal length is equal to or greater than 10 m and less than 50 m,
- 50 cm if nominal length is equal to or greater than 50 m.

6.3 Graduation lines shall be reasonably straight, perpendicular to the longitudinal axis of the tape measure and of uniform thickness and size throughout the length.

6.3.1 Graduation lines shall be so made that they form a clear and distinct scale and that their thickness shall not cause any inaccuracy in reading.

6.3.2 The tape measure shall be graduated only in metric units and graduations or other indications showing or relating to units other than metric units shall not be made on any surface of the tape measure.

6.4 Tape measures above 5 m to 200 m shall be graduated only on one side. Tape measures of 0.5 m to 5 m may be graduated on both sides (only metric scale ).

6.5 The graduation lines, numbers and other markings shall be either in relief, engraved, typographically printed or made in any other suitable manner.

6.6 The zero of the scale may be located at the outer or inner edge of the ring or other device, or may also be located on the tape measure itself, at a length equal to or greater than:

- a) 50 mm from the outer end of the ring or other device, in the case of tape measures of nominal length 0.5 m to 5 m, and
- b) 100 mm from the outer end of the ring or other device, in the case of tape measures of nominal lengths above 5 m.

6.7 Tape measures of denominations 0.5 m to 5 m may be graduated throughout at every millimetre, every 5 millimetres or every 10 millimetres:

- a) The graduation lines at every 10 mm shall be marked in such a manner that there is no confusion between the 100 mm graduation lines and the millimetre or 5 mm graduation lines.
- b) In the case of tape measures graduated at every 5 mm or 10 mm, not less than the first 100 mm shall be subdivided into millimetres.

6.8 In the case of tape measures of nominal length above 5 m, every graduation line at 50 mm shall have the same length as the graduation line at 10 mm but may have an arrow at its end. This requirement shall not apply to tape measures graduated at every millimetre.

6.9 The thickness of the graduation lines shall not exceed the following limits:

0.4 mm in the case of Class I and Class II tape measures, and 0.5 mm in the case of Class III tape measures.

6.10 In the case of tape measures of nominal length 0.5 m to 5 m, the graduation lines may have a length between one fourth and full width of the tape, depending upon convenience. In the case of tape measures of nominal length above 5 m, the length of the graduation lines may be as follows:

- a) for millimetre graduation lines, about one-third of the width of the tape;
- b) for 5 millimetre graduation lines, about half the width of the tape;
- c) for 10 millimetre graduation lines, about two-thirds the width of the tape; and
- d) for 100 millimetre graduation lines and for metre graduation lines as well as for the zero graduation lines, equal to the width of the tape.

## 7 NUMBERING

### 7.1 General Requirements

7.1.1 The numerals shall be indicated clearly, uniformly and indelibly and shall be easily and unambiguously legible.

7.1.2 The position, dimension, shape, colour and contrast of the numerals shall be suitable for the scale and the graduation lines to which they relate.

7.1.3 The numerals shall be marked parallel to or perpendicular to the axis of the tape measure depending upon the intended manner of use of the measure.

7.2 The following graduation lines shall be numbered:

10 mm, for tape measures of nominal length 0.5 to 5 m, and 100 mm, for tape measures of nominal length exceeding 5 m.

7.3 The metre graduation lines shall be numbered and accompanied by the symbol 'm'.

NOTE — The abbreviation may be indicated in the regional script.

7.4 In the case of tape measures of nominal length of 0.5 m to 5 m, the height of the numerals shall be such as would facilitate the reading of the measurement without ambiguity.

7.5 In the case of tape measures of nominal length 5 m and above, after the graduation line at one metre, every graduation line at 100 mm may be marked with an additional numeral, indicating the completed number of metres. The numeral, if provided, may be located just above, below or in line with the numeral of the 100 mm graduation line. The height of this numeral may be approximately half the height of the numerals indicating 100 mm.

7.6 In the case of tape measures of nominal length 5 m and above the height of the numerals, except those given in 7.5 may be:

- a) about 1/3 of the width of the tape, for 10 mm graduation lines,
- b) about 1/2 of the width of the tape, for 100 mm graduation lines, and
- c) about 2/3 of the width of the tape, for metre graduation lines

7.7 If tapes of 0.5 m to 5 m are contained in special container, such container may be marked with its dimension; for example, 50 mm, to facilitate measurement of internal dimensions (see Fig. 5).

## 8 ACCURACY CLASSES AND MAXIMUM PERMISSIBLE ERRORS

### 8.1 Maximum Permissible Error at Initial Verification

8.1.1 At the time of initial verification the maximum permissible error, under reference conditions and for a length demarcated by any two scale marks, is given by accuracy class by the following formulae:

- Class I — Maximum permissible error equals  $(0.1 + 0.1 L)$  mm positive or negative,
- Class II — Maximum permissible error equals  $(0.3 + 0.2 L)$  mm positive or negative,
- Class III — Maximum permissible error equals  $(0.6 + 0.4 L)$  mm positive or negative,

where, 'L' is the value of the length in question, expressed in metres and rounded up to the nearest integral number of metres.

8.1.2 The maximum permissible positive or negative error in the length 'i' between the centre lines of two consecutive scale marks, and the maximum permissible difference between lengths 'i<sub>1</sub>' and 'i<sub>2</sub>' for two consecutive intervals, are specified in the following table for each accuracy class:

Length 'i' of Interval in Question	Maximum Permissible Error or Difference in Millimetres for Accuracy Class		
	I	II	III
$i \leq 1$ mm	0.1	0.2	0.3
1 mm < $i \leq 1$ cm	0.2	0.4	0.6
1 cm < $i \leq 1$ dm	0.3	0.5	0.9

### 8.2 Maximum Permissible Error for Measures in Service

The maximum permissible error for measures in service is equal to twice the maximum permissible error at the time of initial verification, as specified in 8.1.

### 8.3 Reference Conditions

Maximum permissible errors are subject to the following reference conditions.

8.3.1 The reference temperature is normally 27 °C. Under exceptional circumstances, other reference temperatures may be used in certain specific applications.

8.3.2 During tests, length measures for which a tension is specified shall be supported with negligible friction on a horizontal surface over the total length under test and shall be stretched out by the tension indicated on the measure.

8.4 Steel tape measures of nominal length 0.5 m to 5 m shall belong to accuracy class I or Class II.

8.5 Tape measures of nominal length above 5 m to 200 m shall belong to accuracy Class I, Class II or Class III.

## 9 WINDING DEVICE

### 9.1 Automatic Winding Device

#### 9.1.1 Winding Device

The winding device shall be of substantial construction and shall be such that when the tape is withdrawn by hand to any point up to the limit of its measuring capacity, it shall hold at the length withdrawn and shall be capable of being easily rewound.

#### 9.1.2 Case

The case shall be of corrosion resisting metal, suitable plastic material or of a metal with a non-corrosive

## IS 1269 ( Part 2 ) : 1997

finish and shall not be less than 0.50 mm thick. It shall be well-made, smooth finished, with edges and corners rounded off.

### 9.2 Hand Winding Device

#### 9.2.1 Handle

The handle for the winding device shall be suitable for winding the tape on the reel and shall revolve freely without end or side play or stiffness. It shall fold against the reel, and shall have a crank length of not less than 25 mm.

#### 9.2.2 Reel

The reel, winding drum and its mechanism shall be of robust construction. The reel shall rotate freely. The winding drum of the reel shall be provided with a frictional device suitable for preventing spin of the drum and to reduce the back-lash of the tape to a minimum.

#### 9.2.3 Case

Unless otherwise specified by the purchaser, tapes of denominations 10, 15, 20, 30, 50 and 200 metres shall be supplied in a case, made of leather or corrosion-resisting metal or a metal with a corrosion-resisting finish fitted with a winding device.

**9.2.3.1** If it is not wholly made of leather, the case shall be not less than 1.2 mm thick. If the case is wholly made of leather, the thickness of the leather used shall be at least 3 mm.

**9.2.3.2** If metal case is used, it shall be covered with a suitable leather, plastic or leather-cloth as may be specified by the purchaser.

**9.2.3.3** The opening in the case for the tape shall be provided with a durable eye and with rollers for bearing on each side of the opening.

**9.3** When the tape is supported at the reel and a 100-N load is applied at the free-end for five minutes, the tape shall not get loosened from the reel.

**9.3.1** In addition, in the case of tape measures provided with hand-winding arrangement, the following test shall be applied:

‘Pull out approximately half the length of the tape from the case. Give the tape a short, quick pull by hand, with the case hanging freely, so as to release approximately one metre of the tape. Immediately after movement of the hand has ceased, the reel shall not continue to rotate or oscillate. Rewind the tape to its full limit within the case and crank; snap the crank handle shut. There shall be no looseness in the reel which will permit an unwinding of the tape.’

## 10 MARKING

**10.1** Each tape measure shall be legibly and indelibly marked with the following:

- i) nominal length in metres;
- ii) an indication of the location of zero of the scale;
- iii) the manufacturer's name or trade-mark or both; and
- iv) class of accuracy: I, II or III (in an oval)

**10.2** Advertising inscriptions, if made shall be carried out in such a manner that they do not intrude in any way with the use of the tape measure.

### 10.3 BIS Certification Marking

The steel tape measures may also be marked with the Standard Mark.

**10.3.1** The use of the Standard Mark is governed by the provisions of *Bureau of Indian Standards Act, 1986* and the Rules and Regulations made thereunder. The details of conditions under which the licence for the use of Standard Mark may be granted to manufacturers or producers may be obtained from the Bureau of Indian Standards.

## 11 POSITION FOR STAMPING

**11.1** Provision shall be made at the beginning of the tape for affixing the inspector's stamp.



## Bureau of Indian Standards

BIS is a statutory institution established under the *Bureau of Indian Standards Act, 1986* to promote harmonious development of the activities of standardization, marking and quality certification of goods and attending to connected matters in the country.

### Copyright

BIS has the copyright of all its publications. No part of these publications may be reproduced in any form without the prior permission in writing of BIS. This does not preclude the free use, in the course of implementing the standard, of necessary details, such as symbols and sizes, type or grade designations. Enquiries relating to copyright be addressed to the Director (Publications), BIS.

### Review of Indian Standards

Amendments are issued to standards as the need arises on the basis of comments. Standards are also reviewed periodically; a standard along with amendments is reaffirmed when such review indicates that no changes are needed; if the review indicates that changes are needed, it is taken up for revision. Users of Indian Standards should ascertain that they are in possession of the latest amendments or edition by referring to the latest issue of 'BIS Handbook' and 'Standards : Monthly Additions'.

This Indian Standard has been developed from Doc : No. LM 06 ( 0281 ).

### Amendments Issued Since Publication

Amend No.	Date of Issue	Text Affected

## BUREAU OF INDIAN STANDARDS

### Headquarters:

Manak Bhavan, 9 Bahadur Shah Zafar Marg, New Delhi 110002  
Telephones : 323 01 31, 323 94 02, 323 33 75

Telegrams: Manaksanstha  
( Common to  
all offices )

### Regional Offices:

Central : Manak Bhavan, 9 Bahadur Shah Zafar Marg  
NEW DELHI 110002

Telephone

{ 323 76 17  
323 38 41

Eastern : 1/14 C. I. T. Scheme VII M, V. I. P. Road, Maniktola  
CALCUTTA 700054

{ 337 84 99, 337 85 61  
337 86 26, 337 86 62

Northern : SCO 335-336, Sector 34-A, CHANDIGARH 160022

{ 60 38 43  
60 20 25

Southern : C. I. T. Campus, IV Cross Road, CHENNAI 600113

{ 235 02 16, 235 04 42  
235 15 19, 235 23 15

Western : Manakalaya, E9 MIDC, Marol, Andheri (East)  
MUMBAI 400093

{ 832 92 95, 832 78 58  
832 78 91, 832 78 92

Branches : AHMADABAD. BANGALORE. BHOPAL. BHUBANESHWAR.  
COIMBATORE. FARIDABAD. GHAZIABAD. GUWAHATI. HYDERABAD. JAIPUR.  
KANPUR. LUCKNOW. NAGPUR. PATNA. PUNE. THIRUVANANTHAPURAM.