

Indian Standard

**SOLID WASTE MANAGEMENT SYSTEM —
COLLECTION EQUIPMENT — GUIDELINES**

भारतीय मानक

ठोस अपशिष्ट प्रबन्ध तंत्र — संग्रहण उपस्कर — मार्गदर्शिका

(First Reprint NOVEMBER 1990)

UDC 628·463·02

© BIS 1989

BUREAU OF INDIAN STANDARDS
MANAK BHAVAN, 9 BAHADUR SHAH ZAFAR MARG
NEW DELHI 110002

FOREWORD

This Indian Standard was adopted by the Bureau of Indian Standards on 28 February 1989, after the draft finalized by the Solid Wastes Sectional Committee had been approved by the Chemical Division Council.

Solid waste management system (SWMS) for a city consists of various stages, such as, collection, transportation, processing and disposal. The refuse is commonly collected in different areas of the city in dustbins. Nearby residents and road sweepers deposit the solid waste in such dustbins. As the dustbin is common for the population in particular area, it can be termed as 'community dustbin'. The community dustbin serves as an intermediate storage for solid wastes from which the refuse is transported to processing or disposal site.

In developed countries, 'house to house' collection is adopted, namely, collection vehicle goes to every house and collects the refuse. The citizens are also more cooperative to this public service. Level of public awareness to the importance of this system is quite appreciable and hence the citizens expect still better services. Civic agencies in order to give better services expect more cooperation from the citizens. For this purpose, number of bye-laws are framed to ensure a sanitary and hygienic process of collection. In India, due to the absence of any effective bye-laws, the job of municipal corporations becomes more difficult.

In India, normally community bin system is adopted for collection of solid wastes. This system is evolved out of necessity and the need to conserve funds. Equipment used for this work has been developed from the pattern of actual use.

Indian Standard

SOLID WASTE MANAGEMENT SYSTEM — COLLECTION EQUIPMENT — GUIDELINES

1 SCOPE

1.1 This standard prescribes guidelines for collection equipment used in the solid waste management system for cities.

2 REFERENCES

2.1 The following Indian Standards are the necessary adjuncts to this standard:

IS No.	Title
IS 2238 : 1979	Specification for spades and seprangs (first revision)
IS 9569 1980	Glossary of terms relating to solid wastes

3 TERMINOLOGY

3.1 For the purpose of this standard, the definitions given in IS 9569 : 1980 shall apply.

4 COLLECTION OF REFUSE

4.0 During collection of refuse, normally sweepers are allotted specific areas. A sweeper is supposed to sweep the road with his broom. With the help of a steel pan or a basket, he takes the swept refuse to a community dustbin. Such type of collection procedure requires three types of equipment, namely, brooms, collection receptacles and storage receptacles.

4.1 Brooms

These are used for sweeping the area. These can be of short handle and long handle types. Long handle brooms should be used as the worker need not bend while sweeping, leading to lesser contact of dust and lesser strain due to the straight posture while sweeping. The specification of commonly used brooms are as follows.

4.1.1 Long Handled Brooms

Country brooms should be made out of coconut leaf sticks tied firmly to a long wooden handle in accordance with the details given below:

Mass of the broom with rings	: 900 g
Wooden handle	: Length = 1.25 m, Diameter = 25 to 30 mm
Rings (made of 1.0 mm mild steel sheet)	: Width = 20 mm, Diameter = 45 mm
Length of spoke of broom	: Between 850 to 870 mm

4.1.2 Country Broom Without Handle

The broom should be made out of leaf sticks 1 m in length and should be tied firmly together.

4.2 Collection Receptacles

These are used during the process of collection for transferring swept refuse from generation points to 'community dustbin'. These are of following specifications.

4.2.1 Basket

The basket should have an external diameter of 500 mm and an internal depth of 250 mm made out of bamboo sticks or cane and should be free from any kind of decay and insect attack. It should not crack in air (dry condition) on being bent to a circle of 150 mm diameter. The basket can be made out of bamboo strips or cane. For cane basket, the diameter of cane should be 9 ± 3 mm. In case of bamboo baskets, the width of bamboo strip should be 8 ± 4 mm.

4.2.2 Steel Pans (GHAMELAS)

These should be made out of 0.8 mm thick galvanized iron sheet with a pan of 400 mm in diameter and 200 mm in depth.

4.2.3 Spade (POWRAH)

This should be made out of high carbon steel sheet of size $300 \times 300 \times 6$ mm and given a protective coating of black paint. The spade should have 750 mm long teak handle having 40 mm diameter (see IS 2238 : 1979).

4.2.4 Hand Carts

It has been observed that the workers have to strain more while transferring the material with the help of pans or baskets. This is mainly due to two reasons, namely:

- a) The pan or basket has to be taken over the head. Hence, a worker has to work more for transferring the same amount of material; and
- b) The capacity of pans or basket is limited resulting in more number of trips between generation area and community dustbins.

This results in lesser material transferred per shift. Wheel-barrows are recommended to be used for this purpose. The different types of designs commonly used are hand cart with 2 wheels and hand cart with 3 wheels.

The drawings of suggested designs are given in Fig. 1, 2 respectively.

Hand carts with removable containers have recently been introduced in some cities. However, the response of workers and their performance needs to be observed before standardization.

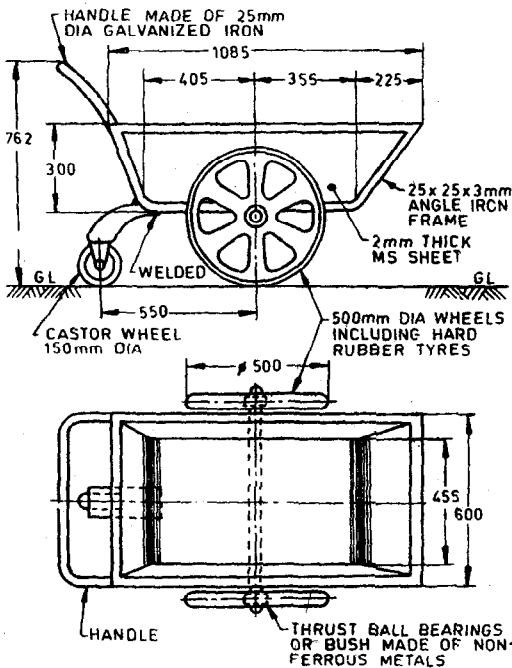

NOTES

1. Axle as suitable to wheels
2. Outside and inside should be given anticorrosive paint
3. Wherever necessary, welding should be adopted
4. Rest to be 10 mm MS rod

All dimensions in millimetres.

FIG. 1 THREE WHEELED WHEEL BARROW

4.3 Storage Receptacles

These are used for temporary storage of refuse. These can be used as community dustbins where-in refuse is temporarily stored after collection from generation area. These are of the following types.

a) Circular Bin

Open on both sides with two handles (1 m dia x 1 m height) made out of 0.794 mm galvanized iron sheet. The bin should be painted with anticorrosive paint on all sides. Circular bins made out of RCC pipe section with two mild steel bar handles can also be used.

b) Rectangular Bin

These are rectangular shaped, generally of brick masonry constructed dustbin. The height of such dustbin is normally limited to 1 m. The cross-section varies in accordance with the avail-

able surface area. Normally, the total volume remains between 3 to 5 m³.

c) Covered Masonry Bin

These are normally provided where larger quantity of refuse has to be stored. Various designs are available which are known by various names in different cities. Capacity ranges up to 15 m³. These are normally provided with two openings for deposition of waste and for its removal.

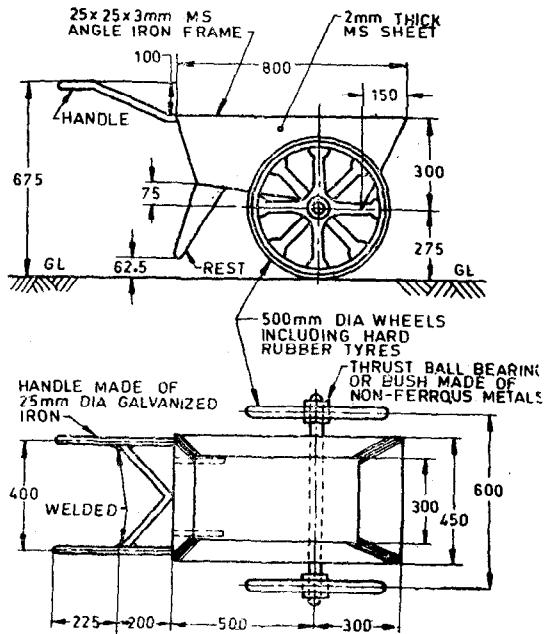

NOTES

1. Axle as suitable to wheels
2. Outside and inside should be given anticorrosive paint
3. Wherever necessary welding should be adopted
4. Rest to be 10 mm MS rod

All dimensions in millimetres.

FIG. 2 TWO WHEELED WHEEL BARROW

4.3.1 Spacing of Dustbin

For efficient collection, it is necessary to have community dustbins placed at suitable sites. If these dustbins are not placed properly, the generated quantity will not reach there completely. This will result in reduction in efficiency of collection stage. The governing factors for spacing of dustbins can be detailed as follows:

- a) Availability of space for installing a dustbin,
- b) Capacity of dustbin,
- c) Population density, and
- d) Average distance convenient to the residents and sweepers for taking the refuse to the dustbin.

4.3.1.1 People are normally reluctant to have a community dustbin installed near to their place. Therefore, it is very difficult to locate it at the most appropriate place. These dustbins are, therefore, commonly located at intersections of roads, near community garden or public utilities and similar other places.

4.3.1.2 Population density plays a very important role in this aspect. Normally, population density varies between 500 to 2 000 persons/hectare. Dustbins of 1 m^3 capacity can accommodate 500 kg of refuse. If the frequency of refuse removal is assumed as once in three days, on daily basis about 165 kg of refuse can be stored in such a dustbin. This means that about 400 persons can be served by this dustbin (assuming refuse generation rate of $0.4 \text{ kg/capita/day}$). At the population density of 500 persons/hectare, the area occupied by 400 persons will be about 0.8 hectares. If this area is considered as

circular, it will have a radius of 50 m. Thus, this dustbin will be able to serve up to a distance of 50 m giving a distance of 100 m between consecutive dustbins.

4.3.1.3 As the population density reduces, the area served by a dustbin of capacity 1 m^3 will be more. This will result in increase in distance through which the residents/sweepers will have to transport the refuse. Obviously, this will not be accepted by the residents and will result in creation of open collection points. To avoid this phenomenon, dustbins of lesser capacity should be installed so that the average distance to be travelled is within the acceptable limits.

4.3.1.4 While fixing the spacing of dustbins, citizens co-operation should be sought and the distance to which they can willingly transport the waste ascertained. When this is done, dumping of refuse at intermediate points can be avoided to maintain a better environment.

Standard Mark

The use of the Standard Mark is governed by the provisions of the *Bureau of Indian Standards Act, 1986* and the Rules and Regulations made thereunder. The Standard Mark on products covered by an Indian Standard conveys the assurance that they have been produced to comply with the requirements of that standard under a well defined system of inspection, testing and quality control which is devised and supervised by BIS and operated by the producer. Standard marked products are also continuously checked by BIS for conformity to that standard as a further safeguard. Details of conditions under which a licence for the use of the Standard Mark may be granted to manufacturers or producers may be obtained from the Bureau of Indian Standards.

Bureau of Indian Standards

BIS is a statutory institution established under the *Bureau of Indian Standards Act, 1986* to promote harmonious development of the activities of standardization, marking and quality certification of goods and attending to connected matters in the country.

Copyright

BIS has the copyright of all its publications. No part of these publications may be reproduced in any form without the prior permission in writing of BIS. This does not preclude the free use, in the course of implementing the standard, of necessary details, such as symbols and sizes, type or grade designations. Enquiries relating to copyright be addressed to the Director (Publications), BIS.

Revision of Indian Standards

Indian Standards are reviewed periodically and revised, when necessary and amendments, if any, are issued from time to time. Users of Indian Standards should ascertain that they are in possession of the latest amendments or edition. Comments on this Indian Standard may be sent to BIS giving the following reference :

Doc : No. CDC 54 (9073)

Amendments Issued Since Publication

Amend No.	Date of Issue	Text Affected

BUREAU OF INDIAN STANDARDS

Headquarters :

Manak Bhavan, 9 Bahadur Shah Zafar Marg, New Delhi 110002
Telephones : 331 01 31, 331 13 75

Telegrams : Manaksanstha
(Common to all Offices)

Regional Offices :

Central : Manak Bhavan, 9 Bahadur Shah Zafar Marg
NEW DELHI 110002

Telephone

{ 331 01 31
{ 331 13 75

Eastern : 1/14 C.I.T. Scheme VII M, V.I.P. Road, Maniktola
CALCUTTA 700054

36 24 99

Northern : SCO 445-446, Sector 35-C, CHANDIGARH 160036

{ 2 18 43
{ 3 16 41

Southern : C.I.T. Campus, 4 Cross Road, MADRAS 600113

{ 41 24 42
{ 41 25 19
{ 41 29 16

Western : Manakalaya, E9 MIDC, Marol, Andheri (East)
BOMBAY 400093

6 32 92 95

Branches : AHMADABAD. BANGALORE. BHOPAL. BHUBANESWAR.
GUWAHATI. HYDERABAD. JAIPUR. KANPUR. PATNA.
TRIVANDRUM.