

IS : 12583 - 1988
(Reaffirmed 1998)
Edition 1.2
(1999-04)

Indian Standard

**SPECIFICATION FOR CORRUGATED
BITUMEN ROOFING SHEETS**

(Incorporating Amendment Nos. 1 & 2)

UDC 69.024.153.3 : 691.165 - 417.2

© BIS 2003

BUREAU OF INDIAN STANDARDS
MANAK BHAVAN, 9 BAHADUR SHAH ZAFAR MARG
NEW DELHI 110002

Price Group 4

Indian Standard

SPECIFICATION FOR CORRUGATED BITUMEN ROOFING SHEETS

0. FOREWORD

0.1 This Indian Standard was adopted by the Bureau of Indian Standards on 20 December 1988, after the draft finalized by the Flooring and Plastering Sectional Committee had been approved by the Civil Engineering Division Council.

0.2 These sheets can be used for temporary applications for limited duration. Proper installation methods as suggested by the manufacturer shall be followed and it is recommended that due caution should be exercised in their use under extreme climatic conditions.

0.3 Purlins provided for bitumen roofing sheets shall not sag under its own weight during its life period and shall be spaced 550 mm centre to centre. Purlins should also be provided on

eaves and the maximum overhang of sheets should be restricted to 75 mm.

0.4 This edition 1.2 incorporates Amendment No. 1 (January 1993) and Amendment No. 2 (April 1999). Side bar indicates modification of the text as the result of incorporation of the amendments.

0.5 For the purpose of deciding whether a particular requirement of this standard is complied with, the final value, observed or calculated, expressing the result of a test, shall be rounded off in accordance with IS : 2-1960*. The number of significant places retained in the rounded off value should be the same as that of the specified value in this standard.

*Rules for rounding off numerical values (*revised*).

1. SCOPE

1.1 This standard specifies the requirements of corrugated bitumen roofing sheets used as light roofing material.

2. MATERIALS

2.1 The bitumen used shall conform to IS 73 : 1992*.

2.2 The paper board used in the manufacture of bitumen roofing sheets shall conform to the requirements given in Table 1.

3. DIMENSIONS AND TOLERANCES

3.1 The standard size of the sheets shall be as follows:

Length (mm)	Width (mm)	Thickness (mm)	Depth of Corrugation (mm)	Pitch of Corrugation (mm)
1 200	750	3 to 5	35	90
1 800	900	3 to 5	35	90

*Specification for paving bitumen (*second revision*).

3.2 The permissible tolerances on dimensions specified in **3.1** shall be as follows:

Dimensions	Tolerances mm
Length	± 5
Width	± 20

NOTE — The thickness of the sheets shall be taken as the average of six measurements along the width and shall be measured with screw gauge having an anvil of 9 mm diameter. The tolerance in thickness shall be +1 mm.

4. MASS

4.1 The mass of the sheets shall conform to those given in Table 2.

5. PHYSICAL REQUIREMENT

5.1 The sheets shall conform to the requirements given in col 3 of Table 3 when tested in accordance with the provisions given in col 4.

TABLE 1 REQUIREMENTS OF PAPER BOARD

(*Clause 2.2*)

Sl. No.	CHARACTERISTIC	REQUIREMENT	METHOD OF TEST
(1)	(2)	(3)	(4)
i)	Thickness, mm	3 to 5	7 of IS : 1060 (Part 1)-1966*
ii)	Weight, kg/m ² for 3 mm thick for 4 mm thick for 5 mm thick	1.50 2.00 2.50	6 of IS : 1060 (Part 1)-1966*
iii)	Ash content, percent	7	11 of IS : 1060 (Part 1)-1966*
iv)	Tensile strength, kg/cm ²	25	12 of IS : 1060 (Part 1)-1966*
v)	Breaking load for 300 mm span, 750 mm width	60 kg	Appendix D

*Methods of sampling and test for paper and allied products : Part 1 (*revised*).

TABLE 2 WEIGHT OF SHEETS
(Clause 4.1)

SL No.	SIZE	THICKNESS	MASS
(1)	(2)	(3)	(4)
	mm	mm	kg
i)	1 200 × 750	3	3 ± 0.2
		4	4 ± 0.2
		5	5 ± 0.2
ii)	1 800 × 900	3	5.4 ± 0.2
		4	7.2 ± 0.2
		5	9.0 ± 0.2

6. FINISH

6.1 The sheets shall have true shape, good appearance and shall be free from visible defects. The corrugations shall be true and regular. The edges of the sheets shall be straight and clean. External surface of the sheets shall be painted.

7. PACKING

7.1 The sheets shall be packed in accordance with the usual trade practice to avoid damage, discoloration, deformation, etc.

8. MARKING

8.1 Each package shall be legibly and indelibly marked with the following information:

- a) Name of the manufacturer or his trade mark;
- b) Batch No. and month and year of manufacture; and
- c) Dimensions.

8.1.1 Each sheet may also be marked with the standard Mark.

NOTE — The use of the Standard Mark is governed by the provisions of the Bureau of Indian Standards Act, 1986 and the Rules and Regulations made thereunder. The Standard Mark on products covered by an Indian Standard conveys the assurance that they have been produced to comply with the requirements of that standard under a well defined system of inspection, testing and quality control which is devised and supervised by BIS and operated by the producer. Standard marked products are also continuously checked by BIS for conformity to that standard as a further safeguard. Details of conditions under which a licence for the use of the Standard Mark may be granted to manufacturers or producers may be obtained from the Bureau of Indian Standards.

9. SAMPLING AND CRITERIA FOR CONFORMITY

9.1 The procedure of sampling and criteria for conformity shall be as given in Appendix M.

TABLE 3 REQUIREMENTS OF CORRUGATED BITUMEN ROOFING SHEETS
(Clause 5.1)

SL. No.	CHARACTERISTIC	REQUIREMENT	METHOD OF TEST, REF TO APPENDIX
(1)	(2)	(3)	(4)
i)	Bitumen content	50 ± 5 percent	A
ii)	Uniformity of impregnation	Bitumen content in outer and central layers of the sheet shall not vary by more than 5 percent	B
iii)	Ash content	Shall not be more than 10 percent	C
iv)	Breaking load	100 kg (1 000 N), <i>Min</i> for all thicknesses	D
v)	Water absorption	Shall not be more than 8 percent	E
vi)	Impermeability	No water or moisture on the lower surface of the test specimen shall be visible or felt	F
vii)	Impact resistance	Shall not tear, break or crack	G
viii)	Wet load bearing capacity	The specimen shall not crack and sag and shall recover from the deflection, if any	H
ix)	Accelerated weathering (type test)	Shall be free from cracks, colour change or any other surface defects. There shall be no change in flexibility and overall appearance when compared to unexposed sheets	J
x)	Temperature susceptibility	a) Shall be no softening or any apparent change of colour, finish, etc	K
		b) Shall not crack or deform	

APPENDIX A

[Table 3, Sl No. (i)]

DETERMINATION OF BITUMEN CONTENT

A-1. OBJECT

A-1.1 To determine the percentage of bitumen content in corrugated bitumen roofing sheets.

A-2. APPARATUS AND REAGENTS

A-2.1 Glass Beaker — 600 ml capacity.

A-2.2 Circulating Air Oven — having thermoplastic control that shall maintain a temperature of 60 ± 2°C.

A-2.3 Balance — capable of measuring to 0.001 g.

A-2.4 Mineral Turpentine — colourless.

A-2.5 Benzene

A-3. TEST SAMPLES

A-3.1 Two test samples (about 0.5 g each) of very small pieces of sheets after removal of the top painted layer.

A-4. PROCEDURE

A-4.1 Weigh the pieces to nearest 0.1 g and place them in the glass beaker. Add 250 ml colourless mineral turpentine. Stir with a glass rod and allow it to stand for 24 h. Decant the supernatant liquid. Add 20 ml of benzene to the residue and shake the beaker. Decant the benzene after 2 h and dry the beaker in the

oven maintained at a temperature of 60°C. Wash and dry the test pieces and weigh again.

A-5. REPORT

A-5.1 The loss in mass shall be expressed as a percentage of original mass and the average value of two test samples recorded to the nearest 0.1 percent shall be recorded.

APPENDIX B

[Table 3, Sl No. (ii)]

DETERMINATION OF UNIFORMITY OF IMPREGNATION**B-1. OBJECT**

B-1.1 To determine asphalt content in the outer and central layers of the sheets.

B-2. APPARATUS

B-2.1 The apparatus and reagents shall be the same as given in **A-2**.

B-3. TEST SPECIMENS

B-3.1 The test specimen shall consist of:

- a) Small pieces (about 0.5 g) of the last but one layer (first below the painted layer) of the sheet.

- b) Small pieces (about 0.5 g) of the central layer of the sheet.

B-4. PROCEDURE

B-4.1 Determine the asphalt content of two layers separately in accordance with the procedure given in **A-4**.

B-5. REPORT

B-5.1 The difference of asphalt content in the two layers shall be reported.

APPENDIX C

[Table 3, Sl No. (iii)]

DETERMINATION OF ASH CONTENT**C-1. OBJECT**

C-1.1 To determine the ash content in corrugated asphaltic roofing sheets.

C-2. APPARATUS**C-2.1 Silica Crucible****C-3. TEST SAMPLE**

C-3.1 Two test samples (about 1 g each) of very small piece of the sheet after removing the top painted surface.

C-4. PROCEDURE

C-4.1 Transfer the piece into silica crucible and weigh. Cover the crucible with a lid and ignite to constant mass.

C-5. CALCULATION

C-5.1 Calculate the ash content as follows:

$$\text{Ash content} = \frac{\text{Mass of ash}}{\text{Mass of piece}} \times 100$$

C-5.2 The average value of two test samples calculated to the nearest 0.1 percent shall be recorded.

APPENDIX D

[Table 3, Sl No. (iv)]

DETERMINATION OF BREAKING LOAD**D-1. OBJECT**

D-1.1 To determine the load at failure for corrugated asphaltic roofing sheets.

D-2. APPARATUS

D-2.1 Two rigid and hard parallel wooden supports of 150 mm depth and 75 mm width with a clear span of 600* mm shall be provided for supporting the test piece. The supports shall

be at right angle to the direction of corrugation of the sheets. A third wooden piece of 225 mm width for application of load to the test piece shall be provided.

D-3. TEST SPECIMEN

D-3.1 Three test pieces each of length and width same as the original sheet.

D-4. PROCEDURE

D-4.1 Support the test piece on two parallel wooden supports. Place the third wooden piece

*Clear span is reduced to 300 mm when paper board is tested.

IS : 12583 - 1988

over the test sample at a position midway between and parallel to the supports (see Fig. 1). Apply the load slowly and gradually with common building bricks till failure occurs.

The load at failure shall be noted.

D-5. REPORT

D-5.1 The average of all the three determinations shall be reported.

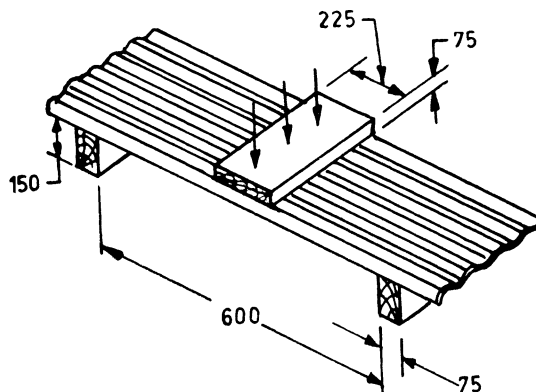

All dimensions in millimetres.

FIG. 1 APPARATUS FOR DETERMINING BREAKING LOAD FOR 600 MM SPAN

APPENDIX E

[Table 3, Sl No. (v)]

DETERMINATION OF WATER ABSORPTION

E-1. OBJECT

E-1.1 To determine the percentage water absorption of corrugated asphaltic roofing sheets.

E-2. TEST SPECIMEN

E-2.1 Five test pieces each measuring 100×100 mm shall be cut from different sheets.

E-3. PROCEDURE

E-3.1 Weigh the test piece and immerse completely in distilled water at a temperature of $27 \pm 2^\circ\text{C}$ for 24 h. Immediately after removal from water, the surface of the test piece shall be wiped dry and then weighed.

E-4. REPORT

E-4.1 The increase in mass shall be calculated as the percentage increase on the original mass and the average value of five determinations shall be reported to the nearest 0.1 percent.

APPENDIX F

[Table 3, Sl No. (vi)]

DETERMINATION OF IMPERMEABILITY

F-1. OBJECT

F-1.1 To determine the impermeability of corrugated asphaltic roofing sheets.

F-2. TEST SPECIMEN

F-2.1 Five test pieces measuring 50×50 mm shall be cut from the flat portion of different sheets.

F-3. APPARATUS

F-3.1 **Transparent Glass Tube** — 600 mm long and 25 mm internal diameter.

F-3.2 **Glass Beaker** — 100 ml capacity.

F-3.3 **Clamp and Stand** — To support the glass tube.

F-4. PROCEDURE

F-4.1 Seal one end of the glass tube to the middle of the test piece by epoxy resin. The sealing of the

tube shall be done at the centre of the valley. Place the glass tube and the test specimen over the glass beaker and hold the glass tube vertically with the help of clamp and stand (see Fig. 2). Fill the tube with water to a height of 300 mm and ensure that water does not leak through the sealing. Maintain the level by adding few drops of oil at the top of the water column. Allow it to stand and examine the lower surface of the test piece after 24 h. Perform the test at $27 \pm 2^\circ\text{C}$ and 65 ± 5 percent relative humidity.

F-5. REPORT

F-5.1 Record the formation of drops of water or traces of moisture at the under surface of the test piece.

F-5.1.1 Average of all determinations shall be reported.

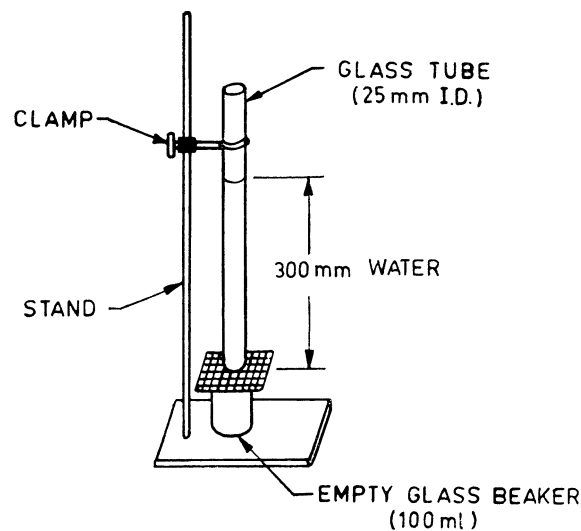

FIG. 2 APPARATUS FOR TESTING IMPERMEABILITY OF SHEET

APPENDIX G

[Table 3, Sl No. (vii)]

DETERMINATION OF IMPACT RESISTANCE

G-1. OBJECT

G-1.1 To determine the resistance to impact of corrugated asphaltic roofing sheets.

G-2. TEST SPECIMEN

G-2.1 Five full size sheets.

G-3. APPARATUS

G-3.1 Wooden purlins of size 50 × 50 mm, span 600 mm and a steel ball of 3 kg shall be provided.

G-4. PROCEDURE

G-4.1 Fix the sheet on the wooden purline at 30° slope. Drop the steel ball on the surface of the sheet midway between the supports from a height of 1 500 mm. The steel ball shall be dropped once.

G-5. REPORT

G-5.1 Report for any tearing of the sheets

APPENDIX H

[Table 3, Sl No. (viii)]

DETERMINATION OF WET LOAD BEARING CAPACITY

H-1 OBJECT

H-1.1 To examine the load bearing capacity of corrugated asphaltic roofing sheets under wet conditions.

H-2. TEST SPECIMEN

H-2.1 Two full size sheets.

H-3. APPARATUS

H-3.1 Wooden purlin supporting frame — dimensions as shown in Fig. 3.

H-3.2 Natural sand — of 200 kg.

H-4. PROCEDURE

H-4.1 Fix the sheet on the purlin frame as shown in Fig. 4 and apply uniformly 50 litres distributed sand load on the sheet to a total weight of 200 kg. Pour water slowly over the entire area of the sheet until it begins to ooze out of edges of the frame containing the sand. Rewet the sand continuously to maintain a fairly uniform moisture content. Carry out the test for seven days.

H-5. REPORT

H-5.1 Record any formation of moisture and cracks on the under surface of the sheet. Average of two determinations, shall be reported.

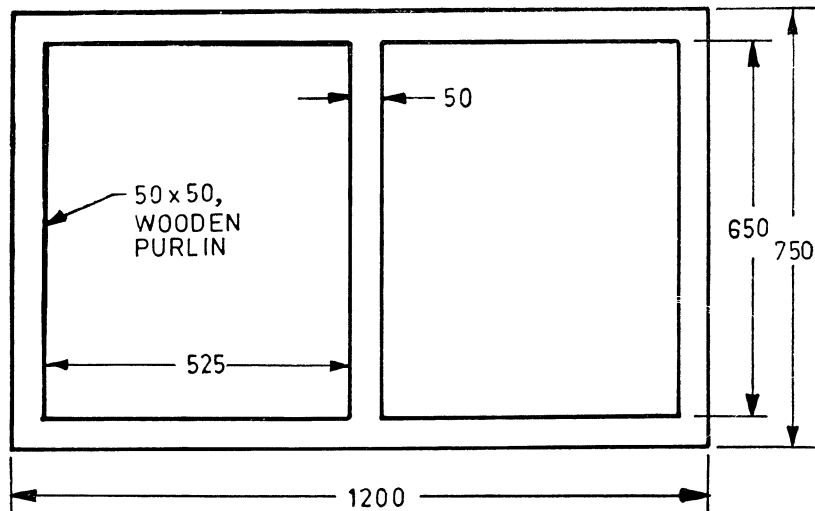

All dimensions in millimetres.
 FIG. 3 WOODEN PURLINS SUPPORTING FRAME FOR TESTING WET LOAD BEARING CAPACITY

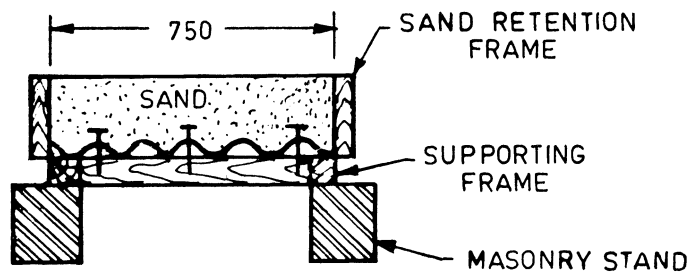

4A Cross Section of Testing Assembly

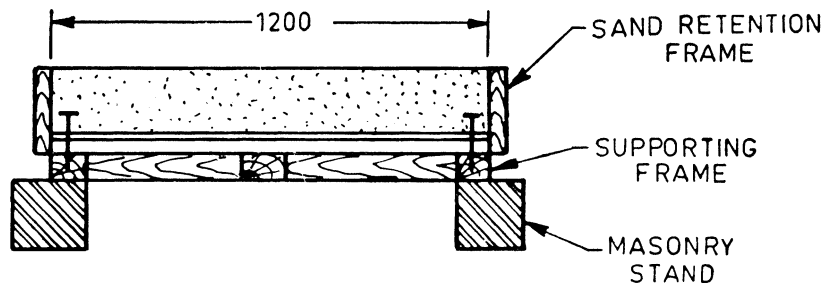

4B Longitudinal Section of Testing Assembly

All dimensions in millimetres.
 FIG. 4 ASSEMBLY FOR TESTING THE WET LOAD BEARING CAPACITY

APPENDIX J

[Table 3, Sl No. (ix)]

DETERMINATION OF ACCELERATED WEATHERING

J-1. OBJECT

J-1.1 To evaluate the effect of sunlight and water on the surface coating of asphaltic sheets and also to examine the overall condition of the material.

J-2. TEST SPECIMEN

J-2.1 Five test pieces measuring 300 × 300 mm shall be cut out from different sheets.

J-3. APPARATUS

J-3.1 Weatherometer — A carbon electrode, twin arc type.

J-4. PROCEDURE

J-4.1 Expose the test specimen for 2 000 hours in the weatherometer under alternate cycles of wetting and drying. The cycles shall consist of 18 min of water spray and sunlight and 102 min of light.

J-5. REPORT

J-5.1 Report for cracks, colour change, flexibility, deterioration, sagging or any other surface defects as compared to unexposed sheets. Average of five determinations shall be reported.

APPENDIX K

[Table 3, Sl No. (x)]

DETERMINATION OF TEMPERATURE SUSCEPTIBILITY**K-1. OBJECT**

K-1.1 To examine the effect of high temperature on the asphaltic sheets.

K-2. TEST SPECIMEN

K-2.1 Five test pieces each measuring 300 × 300 mm shall be cut from the different sheets.

K-3. APPARATUS

K-3.1 Circulating Air Oven — Having thermostatic control that can maintain a temperature of $50 \pm 2^\circ\text{C}$.

K-4. PROCEDURE

K-4.1 Place the test specimens in the oven maintained at a temperature of 50°C for 7 days. Remove the sample from the oven.

K-5. REPORT

K-5.1 Examine the test pieces and report for any softening or apparent change in colour, finish or cracking or any other deformation. Average of five determinations shall be reported.

APPENDIX M

(Clause 9.1)

SAMPLING AND CRITERION FOR CONFORMITY**M-1. LOT**

M-1.1 All the corrugated asphaltic roofing sheets manufactured from same batches of asphalt and paper board under relatively similar conditions of manufacture shall constitute a lot

M-1.2 Each lot shall be taken up individually for sampling and for determining its conformity to the requirements of this specification. For this purpose, the samples shall be taken at random. For random, selection, the procedure for simple random sampling as given in IS : 4905-1968* may be adopted.

M-2. SCALE OF SAMPLING AND CRITERIA FOR CONFORMITY FOR VISUAL AND DIMENSIONAL REQUIREMENTS

M-2.1 The number of sample sheets to be selected from a lot shall depend upon the size of the lot and shall be in accordance with col 1 and 2 of Table 4.

M-2.2 All the sheets selected in **M-2.1** shall be examined for visual and dimensional characteristics. Any sheet failing in any one or more of the visual and dimensional requirements shall be considered to be a

defective sheet. If the number of defective sheets found in the sample is less than or equal to the corresponding number as specified in col 3 of Table 4, the lot shall be considered as satisfying the requirements of visual and dimensional characteristics. However, if the number of defective sheets in the sample is greater than the corresponding permissible number of defectives, the lot shall be deemed as not satisfying the visual and dimensional requirements.

M-3. SCALE OF SAMPLING AND CRITERIA FOR CONFORMITY FOR THE REMAINING REQUIREMENTS OTHER THAN WET LOAD BEARING CAPACITY, ACCELERATED WEATHERING AND TEMPERATURE

M-3.1 The lot which has been found satisfactory in **M-2.1** in respect of visual and dimensional requirements shall be subjected to the remaining tests except for wet load bearing capacity, accelerated weathering and temperature susceptibility. The sheets for this purpose shall be taken at random from those already drawn in **M-2.1**. Each of these tests shall be carried out on sub-sample No. 1 in accordance with col 4 of Table 4.

*Methods for random sampling.

TABLE 4 SCALE OF SAMPLING

(Clauses M-2.1, M-2.2, M-3.1 and M-3.4)

NUMBER OF SHEETS IN THE LOT	NUMBER OF SAMPLE SHEETS FOR VISUAL AND DIMENSIONAL REQUIREMENTS	PERMISSIBLE NUMBER OF DEFECTIVES	SIZE OF SUB-SAMPLE NO. 1	SIZE OF SUB-SAMPLE NO. 2
(1)	(2)	(3)	(4)	(5)
Up to 25	8	0	3	*
26 to 100	13	0	3	*
101 to 500	20	1	3	1
501 and above	32	2	5	2

*Test certificate from the manufacturer required for the acceptance of the lot.

IS : 12583 - 1988

M-3.2 In respect of each of the measurable requirements like asphalt content, uniformity of impregnation, ash content, breaking load and water absorption, from the test results the sample mean (\bar{x}) and the sample range (R , that is, the maximum result — the minimum result) shall be computed.

M-3.2.1 The minimum specified limit shall be deemed to have been satisfied if $(\bar{x} - 0.6R)$ is greater than or equal to the minimum specified limit.

M-3.2.2 The maximum specified limit shall be deemed to have been satisfied if $(\bar{x} + 0.6R)$ is

less than or equal to the maximum specified limit.

M-3.3 In respect of each of the requirements of permeability, impact resistance and wind resistance, all the sheets in the sub-sample No. 1 shall be required to pass individually for the acceptance of the lot.

M-3.4 For wet load bearing capacity, accelerated weathering and temperature susceptibility, the number of sheets to be tested are indicated in sub-sample No. 2 in col 5 of Table 4. Each sample tested for this requirement shall be required to pass the test for the acceptance of the lot.

Bureau of Indian Standards

BIS is a statutory institution established under the *Bureau of Indian Standards Act, 1986* to promote harmonious development of the activities of standardization, marking and quality certification of goods and attending to connected matters in the country.

Copyright

BIS has the copyright of all its publications. No part of these publications may be reproduced in any form without the prior permission in writing of BIS. This does not preclude the free use, in the course of implementing the standard, of necessary details, such as symbols and sizes, type or grade designations. Enquiries relating to copyright be addressed to the Director (Publications), BIS.

Review of Indian Standards

Amendments are issued to standards as the need arises on the basis of comments. Standards are also reviewed periodically; a standard along with amendments is reaffirmed when such review indicates that no changes are needed; if the review indicates that changes are needed, it is taken up for revision. Users of Indian Standards should ascertain that they are in possession of the latest amendments or edition by referring to the latest issue of 'BIS Catalogue' and 'Standards : Monthly Additions'.

This Indian Standard has been developed by Technical Committee : CED 5

Amendments Issued Since Publication

Amend No.	Date of Issue
Amd. No. 1	January 1993
Amd. No. 2	April 1999

BUREAU OF INDIAN STANDARDS

Headquarters:

Manak Bhavan, 9 Bahadur Shah Zafar Marg, New Delhi 110002.
Telephones: 323 01 31, 323 33 75, 323 94 02

Telegrams: Manaksanstha
(Common to all offices)

Regional Offices:

	Telephone
Central : Manak Bhavan, 9 Bahadur Shah Zafar Marg NEW DELHI 110002	{ 323 76 17 323 38 41
Eastern : 1/14 C. I. T. Scheme VII M, V. I. P. Road, Kankurgachi KOLKATA 700054	{ 337 84 99, 337 85 61 337 86 26, 337 91 20
Northern : SCO 335-336, Sector 34-A, CHANDIGARH 160022	{ 60 38 43 60 20 25
Southern : C. I. T. Campus, IV Cross Road, CHENNAI 600113	{ 235 02 16, 235 04 42 235 15 19, 235 23 15
Western : Manakalaya, E9 MIDC, Marol, Andheri (East) MUMBAI 400093	{ 832 92 95, 832 78 58 832 78 91, 832 78 92
Branches : AHMEDABAD. BANGALORE. BHOPAL. BHUBANESHWAR. COIMBATORE. FARIDABAD. GHAZIABAD. GUWAHATI. HYDERABAD. JAIPUR. KANPUR. LUCKNOW. NAGPUR. NALAGARH. PATNA. PUNE. RAJKOT. THIRUVANANTHAPURAM. VISHAKHAPATNAM.	