

भारतीय मानक

कृषि ट्रैक्टरों की संरक्षी संरचनाओं के लिये परीक्षण पद्धति
तथा स्वीकार्यता शर्तें

भाग 2 स्थिर परीक्षण

(पहला पुनरीक्षण)

Indian Standard

METHOD OF TEST AND ACCEPTANCE CONDITIONS
FOR PROTECTIVE STRUCTURES OF
AGRICULTURAL TRACTORS

PART 2 STATIC TEST

(First Revision)

UDC 631.372 : 629.114.2.78 : 620.172

© BIS 1992

BUREAU OF INDIAN STANDARDS

MANAK BHAVAN, 9 BAHADUR SHAH ZAFAR MARG
NEW DELHI 110002

NATIONAL FOREWORD

This Indian Standard (Part 2) (First Revision) which is identical with ISO 5700 : 1989 'Wheeled tractors for agriculture and forestry — Protective structures — Static test method and acceptance conditions', issued by the International Organization for Standardization (ISO) was adopted by the Bureau of Indian Standards on the recommendation of the Agricultural Tractors and Power Tillers Sectional Committee (FAD 32) and approval of the Food and Agriculture Division Council.

This standard (Part 2) was originally issued in 1986 and was identical with ISO 5700 : 1984. This revision has been made by adoption of ISO 5700 : 1989 wherein 'Seat Index Point (SIP)' in place of 'Seat Reference Point (SRP)' has been adopted. The seating position is therefore moved to the mean horizontal from the rearmost position used in the previous edition. Half the minimum horizontal adjustment specified in ISO 4253 is the adjustment figure used.

To adopt the seat index point (SIP) in place of seat reference point (SRP) the relationship of SIP 90 mm above and 140 mm in front of SRP has been used.

In the adopted standard certain terminology and conventions are not identical with those used in the Indian Standards; attention is drawn specially to the following:

- a) Comma (,) has been used as a decimal marker while in Indian Standards the current practice is to use a point (.) as the decimal marker.
- b) Wherever the words 'International Standard' appear, referring to this standard, they should be read as 'Indian Standard'.

CROSS REFERENCE

In this Indian Standard, the following International Standards are referred to. Read in their place the following:

<i>International Standard</i>	<i>Corresponding Indian Standard</i>	<i>Degree of Correspondence</i>
ISO 612 : 1978 Road vehicles — Dimensions of motor vehicles and towed vehicles — Terms and definitions	IS 9435 : 1980 Terms and definitions relating to dimensions of road vehicles	Technically equivalent
ISO 5353 : 1978 Earth-moving machinery, and tractors and machinery for agriculture and forestry — Seat index point	IS 11113 : 1989 Determination of seat index point of earth moving equipment	Technically equivalent
ISO 4253 : 1977 Agricultural tractors — Operators seating accommodation — Dimensions	IS 11243 : 1988 Agricultural tractors— Operators seating accommodation— Dimensions	Not equivalent

Indian Standard

METHOD OF TEST AND ACCEPTANCE CONDITIONS FOR PROTECTIVE STRUCTURES OF AGRICULTURAL TRACTORS

PART 2 STATIC TEST

(First Revision)

1 Scope

This International Standard specifies a static loading test method and the acceptance conditions for protective structures (cab or frame) of wheeled tractors for agriculture and forestry.

It applies to tractors having at least two axles for pneumatic-tired wheels, with or without track attachments, and with a tractor mass not less than 800 kg and not more than 15 000 kg.

NOTE — The limit of 15 000 kg on the tractor mass is based on the extent of research to date. Further studies are required to obtain the basic data to be used for a new edition of this International Standard, which will include tractors with a mass of more than 15 000 kg. However, this International Standard may be considered for use for tractors with a tractor mass greater than 15 000 kg until the new edition of this International Standard has been agreed.

The minimum track width of rear wheels should generally be greater than 1 150 mm. It is recognized that there may be designs of tractors, for example, lawn-mowers, narrow vineyard tractors, low profile tractors used in low buildings with limited overhead clearance, orchards, etc., stilt tractors and certain forestry machines such as forwarders, for which this International Standard is not appropriate.

2 Normative references

The following standards contain provisions which, through reference in this text, constitute provisions of this International Standard. At the time of publication, the editions indicated were valid. All standards are subject to revision, and parties to agreements based on this International Standard are encouraged to investigate the possibility of applying the most recent editions of the standards indicated below. Members of IEC and ISO maintain registers of currently valid International Standards.

ISO 612 : 1978, *Road vehicles — Dimensions of motor vehicles and towed vehicles — Terms and definitions.*

ISO 4253 : 1977, *Agricultural tractors — Operator's seating accommodation — Dimensions.*

ISO 5353 : 1978, *Earth-moving machinery, and tractors and machinery for agriculture and forestry — Seat index point.*

3 Definitions

For the purposes of this International Standard, the following definitions apply.

3.1 protective structure : Cab or frame for the protection of drivers of wheeled tractors for agriculture or forestry by minimizing the likelihood of driver injury resulting from accidental overturning during normal operation.

NOTE — The protective structure is characterized by providing space for the clearance zone either inside the envelope of the structure or within a space bounded by a series of straight lines from the outer edge of the structure to any part of the tractor that might come into contact with flat ground and that is capable of supporting the tractor in that position if the tractor overturns.

3.2 tractor mass : Mass of the unladen tractor in working order with tanks and radiators full, protective structure with cladding, and any track equipment or additional front-wheel drive components required for normal use. The operator, optional ballast weights, additional wheel equipment, special equipment and loads are not included.

3.3 reference mass : Mass, not less than the tractor mass (see 3.2), selected by the manufacturer for calculation of the energy inputs to be used in the tests.

3.4 horizontal loading test : Application of a horizontal load to the rear, front and side of the structure.

NOTE — As loading continues, the cab/frame deformation may cause the direction of loading to change. This is permissible.

3.5 crushing test : Application of a vertical load through a beam placed laterally across the uppermost members of the protective structure.

3.6 longitudinal median plane (of a vehicle) : See ISO 612.

3.7 vertical reference plane (of a vehicle) : Vertical plane generally longitudinal to the tractor and passing through the seat index point and the steering-wheel centre.

NOTE — Normally this reference plane coincides with the longitudinal median plane of the tractor.

4 Symbols

The following symbols are used in this International Standard:

- m_t = reference mass, as defined in 3.3, in kilograms
- D = deflection of the protective structure for the calculated basic energy required at the point of, and in line with, the load application, in millimetres
- F = static load force for the calculated basic energy required, in newtons
- F_{max} = maximum static load force occurring during loading (excluding overload), in newtons
- E_{is} = energy input to be absorbed during side loading, in joules
- E_{il1} = energy input to be absorbed during first longitudinal loading, in joules
- E_{il2} = energy input to be absorbed during a second longitudinal loading, in joules
- F_r = applied force at rear in the crushing test, in newtons
- F_f = applied force at front in the crushing test, in newtons

5 Apparatus

5.1 Horizontal loading tests

5.1.1 Material, equipment and attachment means to ensure that the tractor chassis is firmly fixed to the ground (and supported) independently of the tyres.

5.1.2 Means to apply a horizontal force to the protective structure, such as shown in figures 2 and 3, complying with the requirements of 5.1.2.1 to 5.1.2.4.

5.1.2.1 It shall be ensured that the load can be uniformly distributed normal to the direction of loading and along a beam of length between 250 and 700 mm, in an exact multiple of 50 mm.

5.1.2.2 The edges of the beam in contact with the protective structure shall be curved with a maximum radius of 50 mm.

5.1.2.3 Universal joints, or the equivalent, shall be incorporated to ensure that the loading device does not constrain the structure in rotation or translation in any direction other than the loading direction.

5.1.2.4 Where the protective structure length, covered by the appropriate load-applying beam, does not constitute a straight line normal to the load application direction, the space shall be packed so as to distribute the load over this length.

5.1.3 Equipment to measure force and deflection along the direction of application of the force and relative to the tractor chassis. To ensure accuracy, measurements shall be taken as continuous recordings. The measuring devices shall be located so as to record the force and deflection at the point of, and along the line of, loading.

5.1.4 Means to prove that the clearance zone has not been entered during the test. A measuring rig based on the clearance zone as shown in figure 5 can be used.

5.2 Crushing tests

5.2.1 Material, equipment and attachment means to ensure that the tractor chassis is firmly fixed to the ground (and supported) independently of the tyres.

5.2.2 Means to apply a downward force on the protective structure, such as shown in figure 4, including a stiff beam with a width of 250 mm.

5.2.3 Equipment to measure total vertical force applied.

5.2.4 Means for proving that the clearance zone has not been entered during the test. A measuring rig based on the clearance zone as shown in figure 5 can be used.

6 Preparation of tractor and protective structure

6.1 The protective structure shall be to production specifications and shall be fitted to the appropriate tractor model chassis in accordance with the manufacturer's declared attachment method.

6.2 The assembly shall be secured to the bedplate so that the members connecting the assembly and the bedplate do not deflect significantly in relation to the protective structure under loading. The assembly shall not receive any support under loading other than that due to the initial attachment.

6.3 A track width setting for the rear wheels if present shall be chosen such that no interference exists with the protective structure during the tests.

The assembly shall be supported and secured or modified so that all the test energy is absorbed by the protective structure and its attachment to the tractor rigid components.

6.4 All detachable windows, panels and removable non-structural fittings shall be removed so that they do not contribute to the strength of the protective structure.

In cases where it is possible to fix doors and windows open or remove them during work, they shall be either removed or fixed open for the test, so that they do not add to the strength of the protective structure. It shall be noted whether, in this position, they would create a hazard for the driver in the event of overturning.

6.5 The protective structure shall be instrumented with the necessary equipment to obtain the required force—deflection data.

7 Procedure

7.1 Sequence of tests

7.1.1 The test shall be carried out in accordance with the procedures given in a) to e) and in this sequence :

a) First longitudinal loading

For a tractor with at least 50 % of its tractor mass on the rear wheels, the longitudinal loading shall be applied from the rear. For other tractors the longitudinal loading shall be applied from the front.

b) First crushing test

The first crushing test shall be applied at the same end of the protective structure as the longitudinal loading.

c) Loading from the side

In the case of an offset seat and/or non-symmetrical strength of the protective structure, the side loading shall be on the side most likely to lead to entering the clearance zone.

d) Second crushing test

The second crushing test shall be applied at the opposite end of the protective structure to the longitudinal loading.

NOTE — In the case of two-post designs, it may be at the same point as in b).

e) Second longitudinal loading

A second longitudinal loading shall be applied to tractors fitted with a protective structure designed to be tilted when the longitudinal loading in a) was not applied in the direction in which the protective structure is designed to tilt.

7.1.2 All tests shall be performed on the same protective structure. No repairs or straightening of any member shall be carried out between tests.

7.1.3 On completion of all tests, permanent deflections of the protective structure shall be measured and recorded.

After each part test in 7.1.1, the protective structure shall be inspected visually with the load removed. If cracks or tears have occurred during loading other than during the second crushing test, the overload test specified in 11.3 shall be carried out before proceeding to the next loading in the sequence given in 7.1.1.

7.2 Horizontal loading from rear, front and side

7.2.1 General requirements for horizontal loading tests

7.2.1.1 The loads applied to the protective structure shall be distributed by means of a stiff beam, complying with the requirements of 5.1.2, located normal to the direction of load application; the stiff beam may have a means of preventing its being displaced sideways. The rate of load application shall be such that it can be considered static. As the load is applied, F and D shall be recorded simultaneously as continuous recordings, to ensure accuracy. Once the initial application has commenced, the load shall not be reduced until the test has been completed; but it is permissible to cease increasing the load if desired, for example, to record measurements.

NOTE — The rate of load application can be considered static if the rate of deflection under loading is not greater than 5 mm/s.

7.2.1.2 If the structural member to which the load is to be applied is curved, the requirements of 5.1.2.4 shall be met. The application of the load shall, however, still comply with the requirements of 7.2.1.1 and 5.1.2.

7.2.1.3 If no structural cross-member exists at the application point, a substitute test beam which does not add strength to the structure may be used to complete the test procedure.

7.2.2 First longitudinal loading

The load shall be applied horizontally and parallel to the longitudinal median plane of the tractor from the rear or the front as required by 7.1.1 a). If from the rear, it shall be applied to the opposite side to that to which the side load is applied. If from the front, it shall be to the same side as the side load.

The load shall be applied to the uppermost transverse structural member of the protective structure (i.e. that part which would be likely to strike the ground first in an overturning accident).

The load application point shall be at one-sixth of the width of the protective structure top inwards from the outside corner. The protective structure width shall be taken as the distance between two lines parallel to the longitudinal median plane of the tractor and touching the outside extremities of the protective structure in the horizontal plane touching the top of the uppermost transverse structural members.

The beam length shall be not less than one-third of the protective structure width (as described above) and not more than 49 mm over this minimum.

The test shall be stopped when

a) the strain energy absorbed by the protective structure is equal to or greater than the required input energy (E_{i1}), in joules, where

$$E_{i1} = 1,4 m_t$$

or,

b) the protective structure enters the clearance zone (see clause 9) or leaves it unprotected.

7.2.3 Loading from side

The load from the side shall be applied horizontally normal to the longitudinal median plane. It shall be applied to the protective structure upper extremity at a point generally 85 mm¹⁾ forward of the seat index point (see figure 3 and clause 8).

If it is certain that any particular part of the cab side will touch the ground first when the tractor overturns sideways, the loading shall be applied at that point, provided that this permits uniform load distribution as specified in 7.2.1. In the case of a two-post structure, side loading shall be applied at the structural member uppermost on the side, regardless of the seat index point.

The beam length shall be as long as practicable, subject to a maximum of 700 mm.

The test shall be stopped when

- a) the strain energy absorbed by the protective structure is equal to or greater than the required input energy (E_{is}), in joules, where

$$E_{is} = 1,75 m_t$$

or,

- b) the protective structure enters the clearance zone (see clause 9) or leaves it unprotected.

7.3 Crushing tests

7.3.1 Crushing at rear

The beam shall be positioned across the rear uppermost structural members and the resultant of crushing forces shall be located in the vertical reference plane. The force F_r shall be applied, where $F_r = 20 m_t$, in newtons. This force shall be maintained for at least 5 s after the cessation of any visually detectable movement of the protective structure.

Where the rear part of the protective structure roof will not sustain the full crushing force, the force shall be applied until the roof is deflected to coincide with the plane joining the protective structure upper part with that part of the tractor rear capable of supporting the vehicle mass when overturned. The force shall then be removed and the tractor or loading force repositioned so that the beam is over that point of the protective structure which would then support the tractor front when completely overturned and the full force applied.

7.3.2 Crushing at front

The beam shall be positioned across the front uppermost structural members and the resultant of crushing forces shall be located in the vertical reference plane. The force F_f shall be applied where $F_f = 20 m_t$, in newtons. This force shall be maintained for at least 5 s after the cessation of any visually detectable movement of the protective structure.

Where the front part of the protective structure roof will not sustain the full crushing force, the force shall be applied until the roof is deflected to coincide with the plane joining the protective structure upper part with that part of the tractor front capable of supporting the vehicle mass when overturned. The force shall then be removed and the tractor or loading force repositioned so that the beam is over that part of the protective structure which would then support the tractor rear when completely overturned and the full force applied.

7.4 Second longitudinal loading

The second longitudinal loading shall be applied in the opposite direction to and at the corner furthest from the longitudinal loading in 7.2.2 but otherwise as described in 7.2.1.

The test shall be stopped when

- a) the strain energy absorbed by the protective structure is equal to or greater than the required input energy (E_{il2}), in joules, where

$$E_{il2} = 0,35 m_t$$

or,

- b) the protective structure enters the clearance zone (see clause 9) or leaves it unprotected.

8 Seat index point

The seat index point (SIP) shall be determined in accordance with ISO 5353.

For a suspended seat, the seat shall be set to the suspension travel mid-point, unless this is contradictory to clearly stated instructions by the seat manufacturer. Where special instructions for the seat setting exist, these shall be observed.

9 Clearance zone

9.1 The clearance zone is illustrated in figures 5, 6 a) and 6 b). Referring to the figures, the zone is defined in relation to the vertical reference plane (see 3.7). This reference plane shall be assumed to move horizontally with the seat and steering-wheel during loading but to remain perpendicular to the tractor or the protective structure floor.

9.2 The clearance zone specified in 9.3 a) to j) assumes a seat adjustment of ± 75 mm horizontally and ± 30 mm vertically from the seat mid-position. Where the seat adjustment exceeds these values the clearance zones shall be modified in accordance with 9.2.1 and 9.2.2.

1) See 9.2.

9.2.1 If the horizontal seat adjustment provided exceeds ± 75 mm from the mid-position, then any dimensions forward from the SIP shall be reduced, and dimensions to the rear from the SIP increased, on the basis:

[Total adjustment to the rear of the seat mid-position minus 75 mm]

9.2.2 If the vertical seat adjustment provided exceeds ± 30 mm then any dimensions above the SIP shall be increased and dimensions below the SIP reduced, on the basis:

[Total adjustment above the seat mid-position minus 30 mm]

9.3 The clearance zone (see figures 5 and 6) is defined as in a) to j) when the tractor is standing on its wheels on a horizontal surface, with, where applicable, the steering-wheel adjusted to the mid-position for seated driving.

a) a horizontal plane — $A_1 B_1 B_2 A_2$ — 840 mm¹⁾ above the SIP with line $B_1 B_2$ located 65 mm¹⁾ behind the SIP;

b) an inclined plane — $G_1 G_2 I_2 I_1$ — perpendicular to the vertical reference plane and including the rearmost point of the seat backrest extended rearwards by 75 mm¹⁾ and upwards by 30 mm¹⁾, the extension of which passes through a point 840 mm¹⁾ above the SIP, 215 mm¹⁾ behind the SIP;

c) a cylindrical surface — $A_1 A_2 I_2 I_1$ — perpendicular to the vertical reference plane, with a radius of 120 mm tangential to the planes defined in a) and b);

d) a cylindrical surface — $B_1 C_1 C_2 B_2$ — perpendicular to the vertical reference plane, having a radius of 900 mm and centre 65 mm¹⁾ behind and 60 mm¹⁾ below the SIP (see figures 5 and 6), with the line $C_1 C_2$ located 400 mm¹⁾ forward of $B_1 B_2$;

e) an inclined plane — $C_1 D_1 D_2 C_2$ — perpendicular to the vertical reference plane, joining the surface defined in d) at its forward edge and passing 40 mm from the steering-wheel rim;

f) a vertical plane — $D_1 E_1 E_2 D_2$ — perpendicular to the vertical reference plane 40 mm forward of the steering-wheel forward edge;

g) a horizontal plane — $E_1 F_1 F_2 E_2$ — 60 mm¹⁾ below the SIP;

h) a surface, curved if necessary — $G_1 F_1 F_2 G_2$ — from the bottom limit of the plane defined in b) to the horizontal plane defined in g), following the general direction of and parallel to a surface in contact with the seat backrest rear surface extended rearwards by 75 mm¹⁾ and upwards by 30 mm¹⁾;

i) vertical planes — $J_1 E_1 F_1 G_1 H_1$ and $J_2 E_2 F_2 G_2 H_2$ — at not less than 250 mm on either side of the vertical reference plane, where the distance $E_1 E_2$ shall be equal to the steering-wheel diameter plus 40 mm on each side of the steering-wheel rim or 500 mm, whichever is greater;

j) parallel planes — $A_1 B_1 C_1 D_1 J_1 H_1 I_1$ and $A_2 B_2 C_2 D_2 J_2 H_2 I_2$ — inclined so that the plane upper edge on the side to which the side blow is struck is at least 100 mm from the vertical reference plane.

10 Tolerances

Measurements during the tests shall be made to the following tolerances :

- a) dimensions of the protective structure and clearance zone : ± 3 mm;
- b) deflection : ± 3 mm;
- c) tractor mass : ± 20 kg;
- d) force applied in horizontal and crushing tests : ± 2 %;
- e) deviation from the direction of the applied force :
 - at start of test (under zero load) : $\pm 2^\circ$;
 - during test (under load) : $+10^\circ$ above and -20° below the horizontal;

NOTE — The test rig should be designed to keep these deviations to the minimum possible.

11 Acceptance conditions

For the protective structure to be accepted it shall fulfil the conditions in 11.1 to 11.6 during and after the tests. On articulated tractors, the clearance zone shall remain protected at any angle of articulation of the tractor when overturned.

11.1 No part shall enter the clearance zone as defined in clause 9. No part may strike the seat during the tests. Furthermore, the clearance zone shall not be outside the protective structure protection, as defined in 3.1. For this purpose, it shall be considered to be outside the protective structure protection if any part of it would have come into contact with flat ground if the tractor had overturned towards the direction from which the load was applied. To estimate this, the tyres and track width setting shall be the smallest standard fitting specified by the manufacturer.

11.2 At the point where the required energy is met in each of the specified horizontal loading tests, the force shall exceed $0,8 F_{max}$.

11.3 An overload test to determine the residual strength of the protective structure after a horizontal loading test which may have caused cracks, tears or buckling may be required to ensure adequate residual strength to resist a potential multiple upset accident. [See figures 1 a) to 1 c).]

11.3.1 An overload test shall be required if the force drops more than 3 % over the last 5 % of the deflection attained while absorbing the required energy. [See figure 1b).]

1) See 9.2.

11.3.2 An overload test shall consist of continuing the horizontal loading in increments of 5 % of the original required energy up to a total of 20 % additional energy. [See figure 1c.]

11.3.2.1 The overload test shall be successfully completed if after the absorption of 5 %, 10 % or 15 % additional energy, the force drops by less than 3 % for each 5 % increment, and the force is greater than $0,8 F_{max}$.

11.3.2.2 The overload test shall be successfully completed if after the absorption of 20 % additional energy, the force is greater than $0,8 F_{max}$.

11.3.2.3 Entry into the clearance zone or lack of protection of the clearance zone is permitted during this overload test. After removing the load, the structure shall not be in the clearance zone and shall protect the clearance zone.

11.4 There shall be no protruding member or component which would be likely to cause serious injury during an overturning accident or which, through the deformation occurring, might trap the operator, for example, by a leg or foot.

11.5 There shall be no other components presenting a serious hazard to the operator.

11.6 If the protective structure is claimed to have properties resistant to cold weather embrittlement, the manufacturer shall give details which shall be included in the report (see clause 14).

One method of providing this information is to carry out the tests given in clause 7 at $-18\text{ }^{\circ}\text{C}$ or colder. Other appropriate methods are given in annex A.

12 Extension to other tractor models

In the case of a protective structure which has fulfilled the conditions required for acceptance and which is designed to be used on other tractor models, the test as specified in clause 7 need not be carried out on each tractor model, provided that the protective structure and tractor comply with the conditions specified in 12.1 to 12.4.

In such cases, the test report shall contain a reference to the previous test report.

12.1 The mass of this tractor, used in the test, shall not exceed the reference mass by more than 5 %.

12.2 The attachment method and the tractor components to which the attachment is made shall be identical or of equivalent strength.

12.3 Any components, such as mudguards and bonnet, which may provide support for the protective structure shall be identical or judged to give at least the same support.

12.4 The position and critical dimensions of the seat in the protective structure and the relative position of the tractor protective structure shall be such that the clearance zone would have remained within the protection of the deflected structure throughout all the tests.

13 Labelling

If a label is required it shall be durable and permanently attached to the main structure such that it can be easily read. It shall be protected from damage and it shall contain at least the following information :

- a) name and address of the manufacturer or constructor of the protective structure;
- b) protective structure identification number;
- c) tractor make, model(s) or series number(s) the structure is designed to fit;
- d) number of the International Standard(s) according to which the protective structure has proved to fulfil the stated performance requirements (for example, ISO 3463, ISO 5700);

14 Test report

The test report shall be in accordance with annexes B and C.

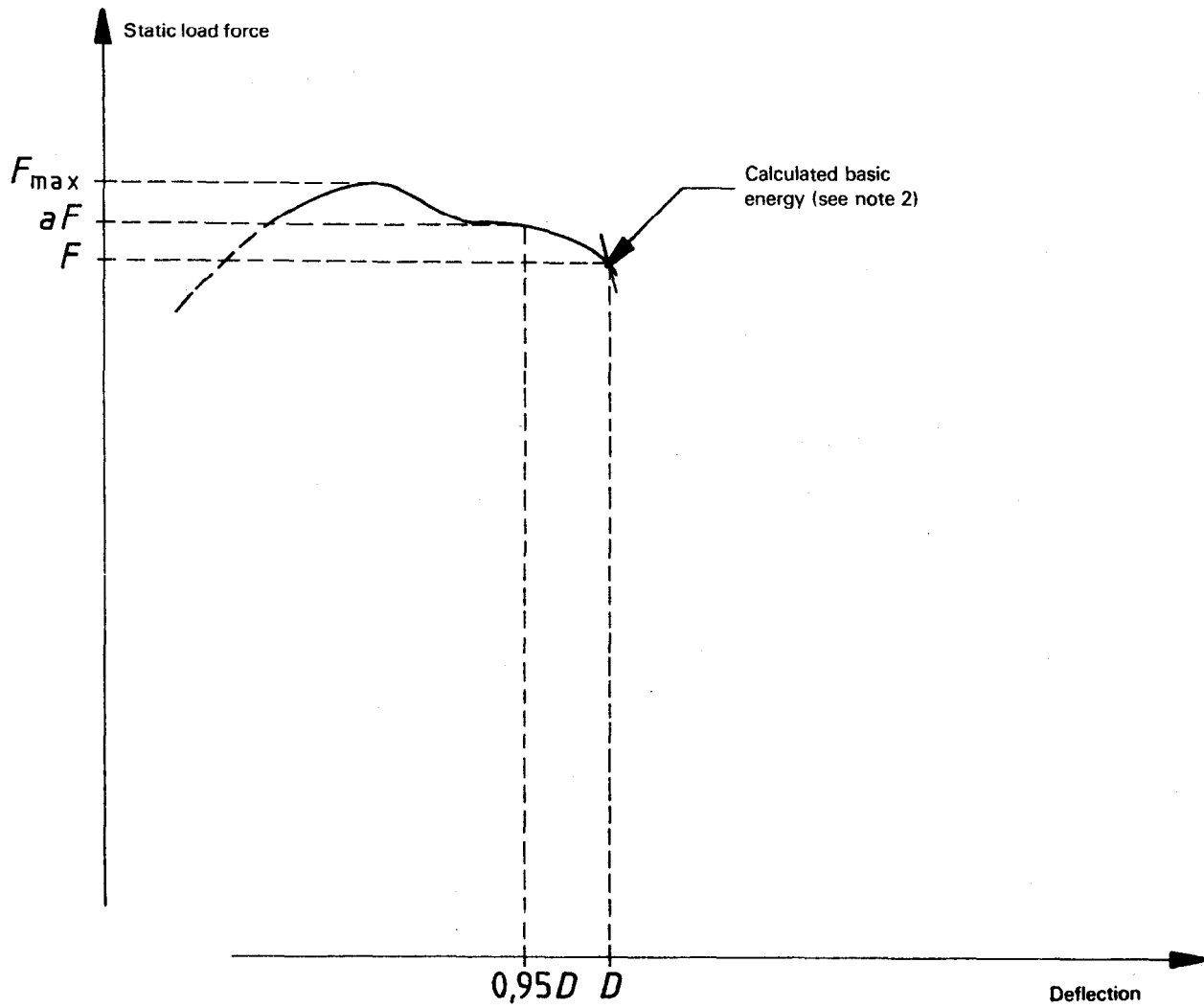

NOTES

- 1 Locate aF in relation to $0,95D$.
- 2 Overload test not necessary as $aF < 1,03F$.

Figure 1a) – Static load force–deflection diagram – Overload test not necessary

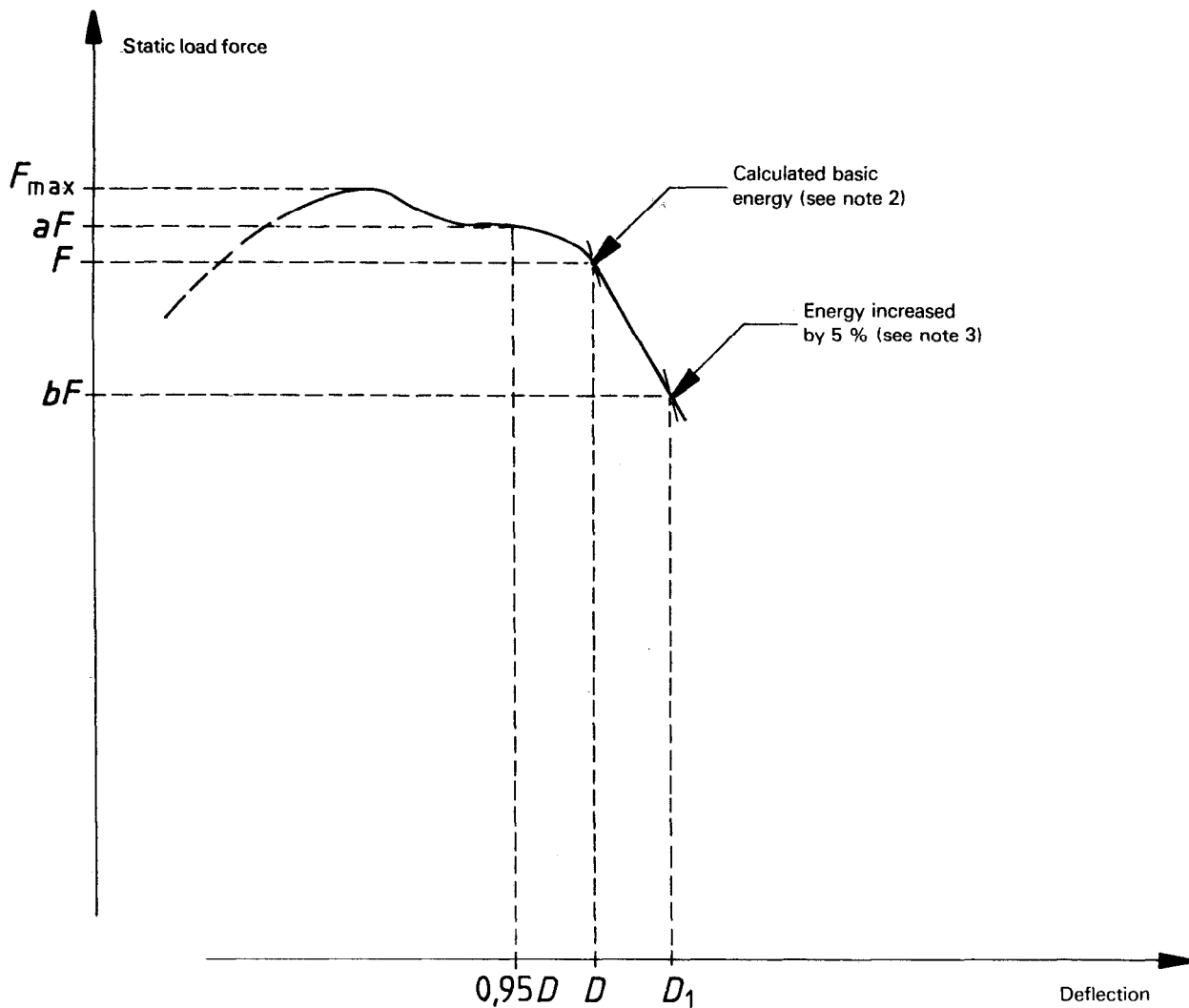

NOTES

- 1 Locate aF in relation to $0,95D$.
- 2 Overload test necessary as $aF > 1,03F$.
- 3 Overload test performance satisfactory as $bF > 0,97F$ and $bF > 0,8F_{max}$.

Figure 1b) – Static load force – deflection diagram – Overload test

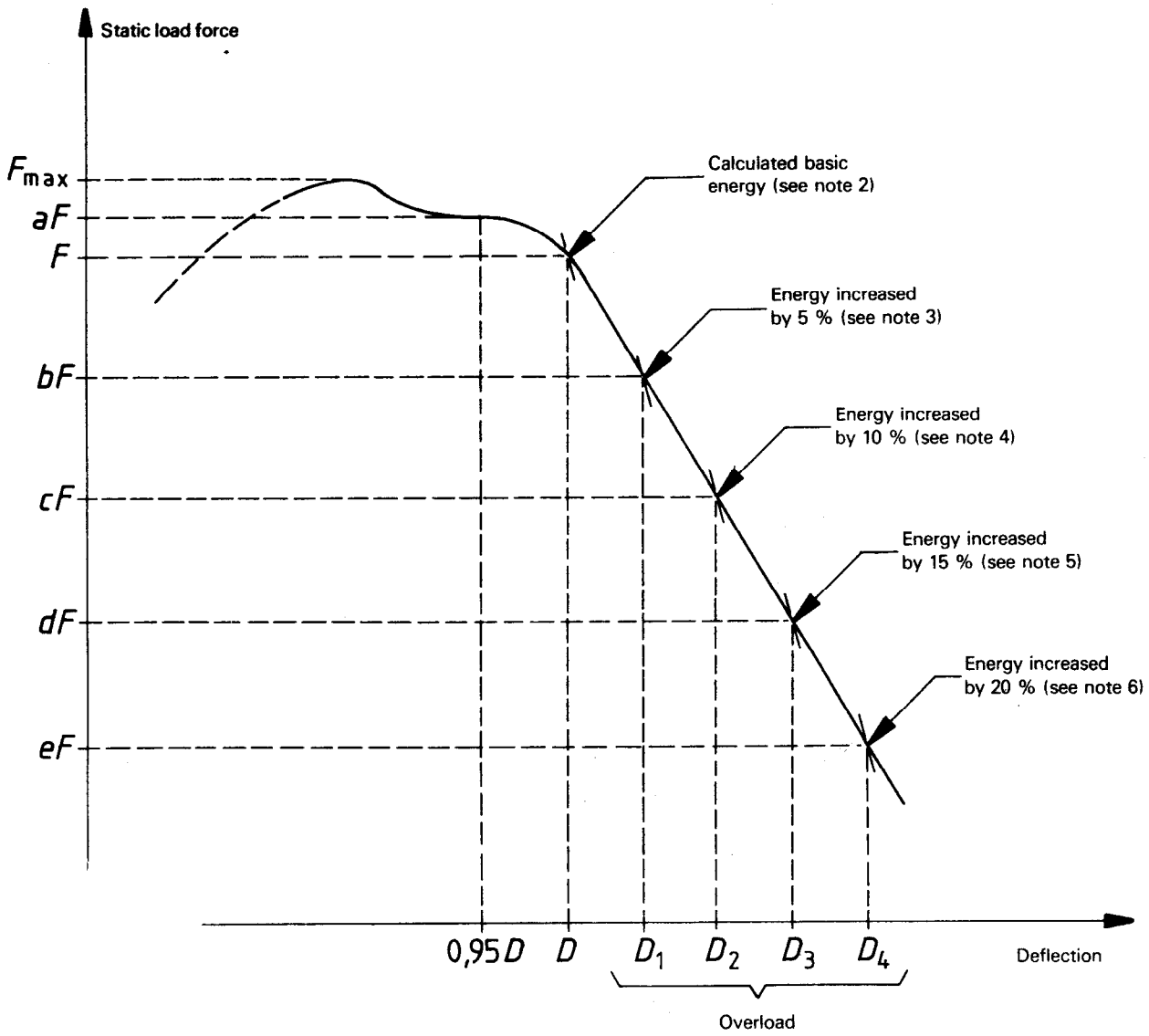

NOTES

- 1 Locate aF in relation to $0,95D$.
- 2 Overload test necessary as $aF > 1,03F$.
- 3 $bF < 0,97F$ therefore further overload necessary.
- 4 $cF < 0,97bF$ therefore further overload necessary.
- 5 $dF < 0,97cF$ therefore further overload necessary.
- 6 Overload test performance satisfactory as $eF > 0,8 F_{max}$.
- 7 Failure at any stage when load drops below $0,8 F_{max}$.

Figure 1c) — Static load force — deflection diagram — Continuing overload test

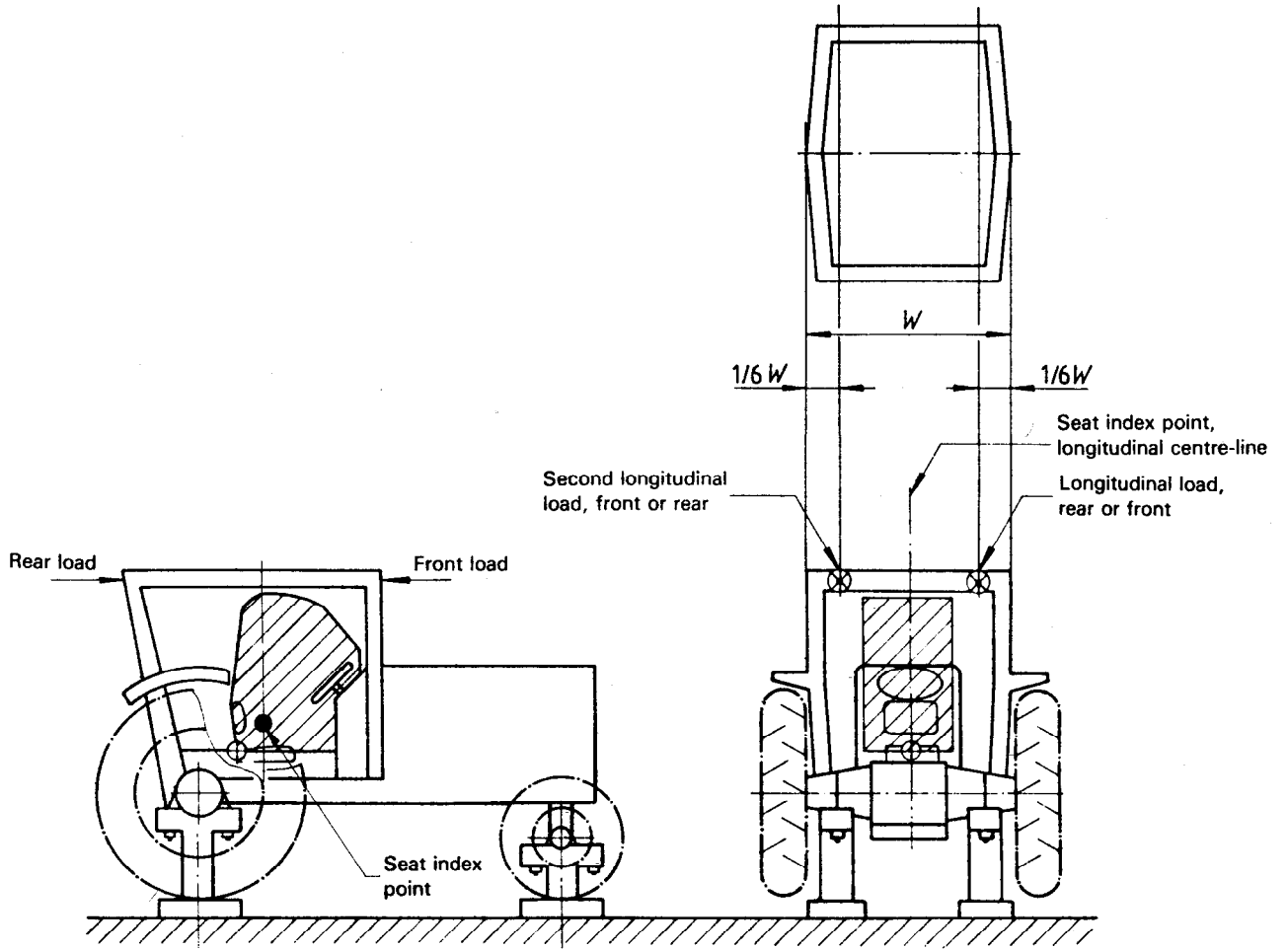

Figure 2 – Front and rear load application

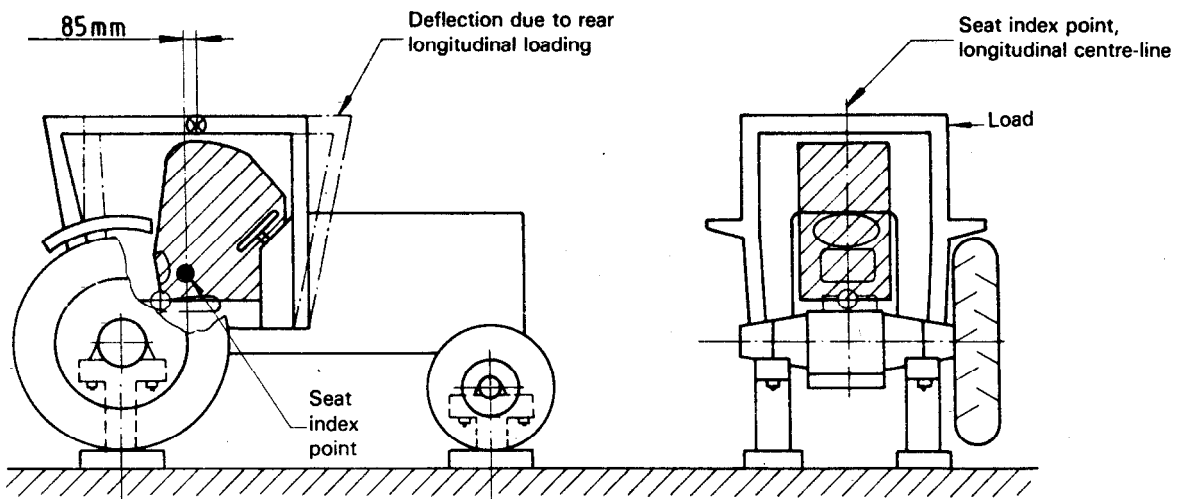

Figure 3 – Side load application

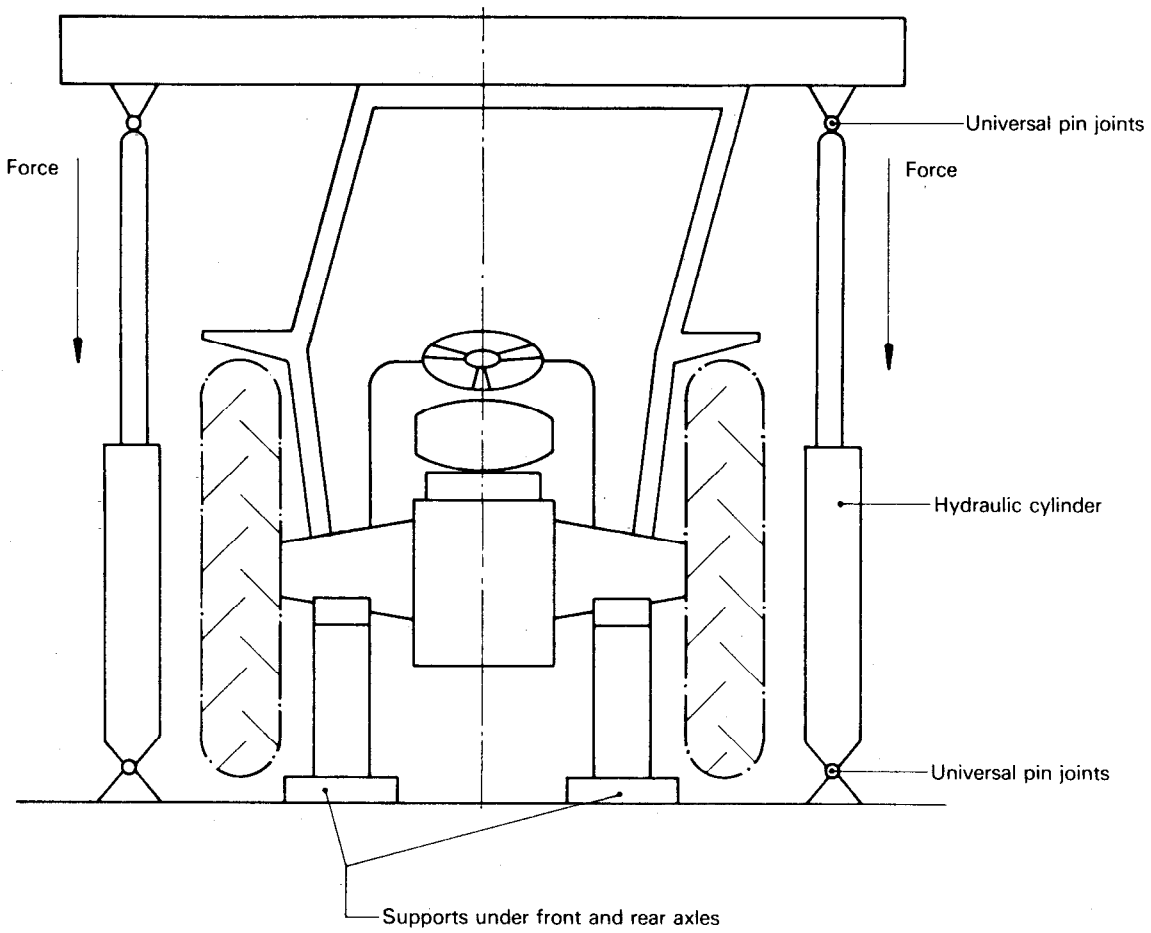
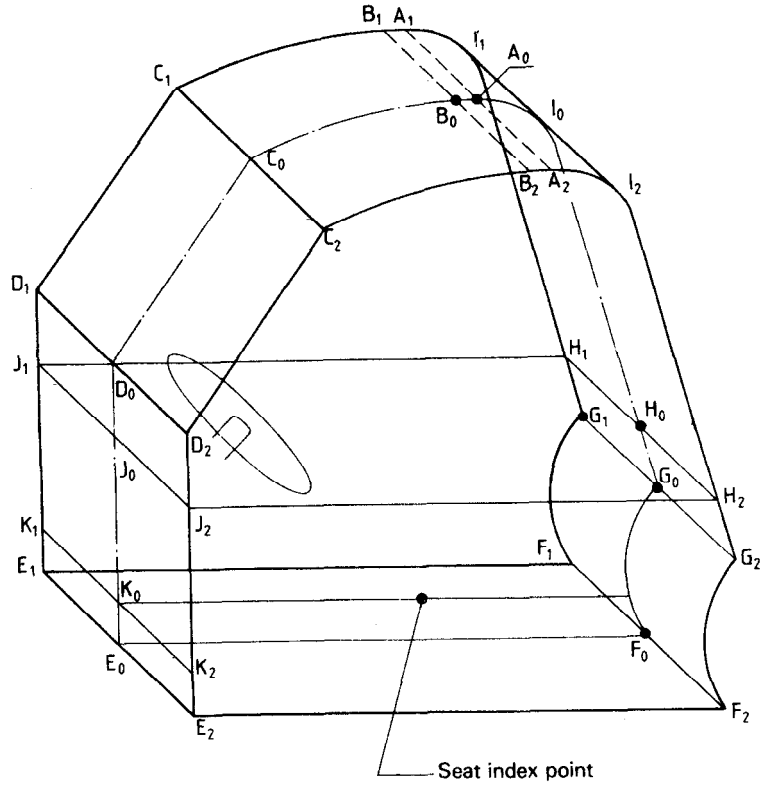

Figure 4 – Example of arrangement for crushing test



Dimension		Remarks
mm		
A_1A_0	100	Minimum
B_1B_0		
A_1A_2	500	Minimum or equal to the steering-wheel radius plus 40 mm, whichever is greater
B_1B_2		
C_1C_2		
D_1D_2	500	Minimum or equal to the steering-wheel radius plus 40 mm, whichever is greater
E_1E_2		
F_1F_2	500	Minimum or equal to the steering-wheel radius plus 40 mm, whichever is greater
G_1G_2		
H_1H_2		
I_1I_2		
J_1J_2		
E_1E_0	250	Minimum or equal to the steering-wheel radius plus 40 mm, whichever is greater
E_2E_0		
J_0E_0	300	Depending on the tractor
F_0G_0		
I_0G_0		
C_0D_0		
E_0F_0		

NOTE -- For other dimensions, see figures 6a) and 6b).

Figure 5 -- Clearance zone

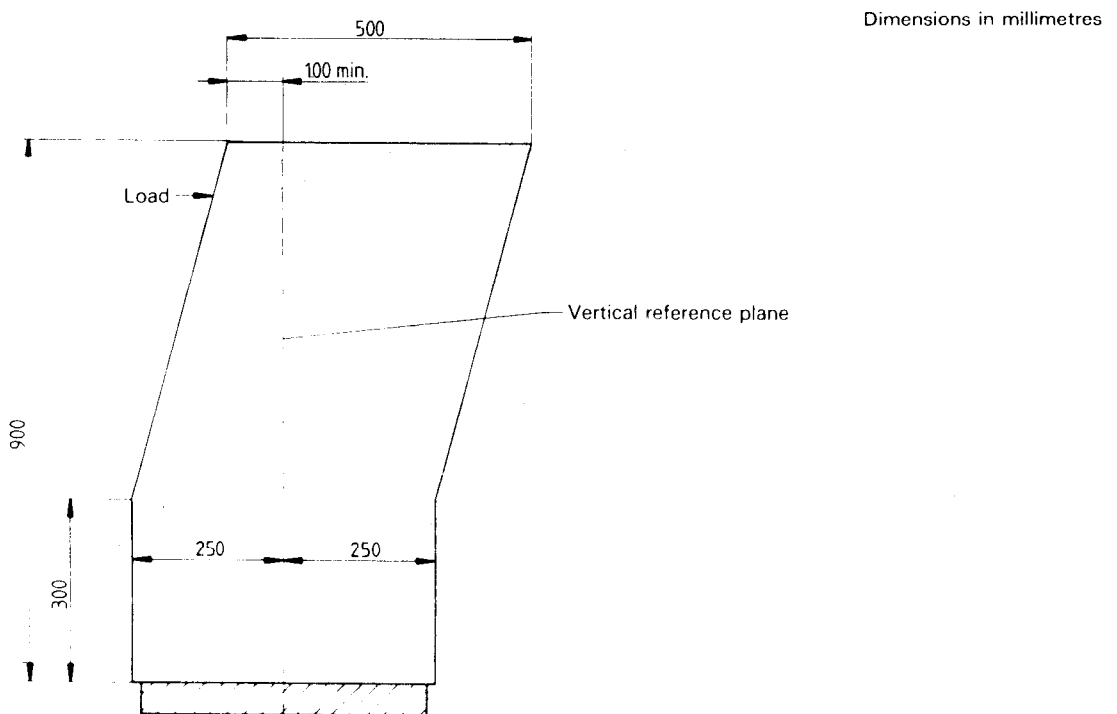
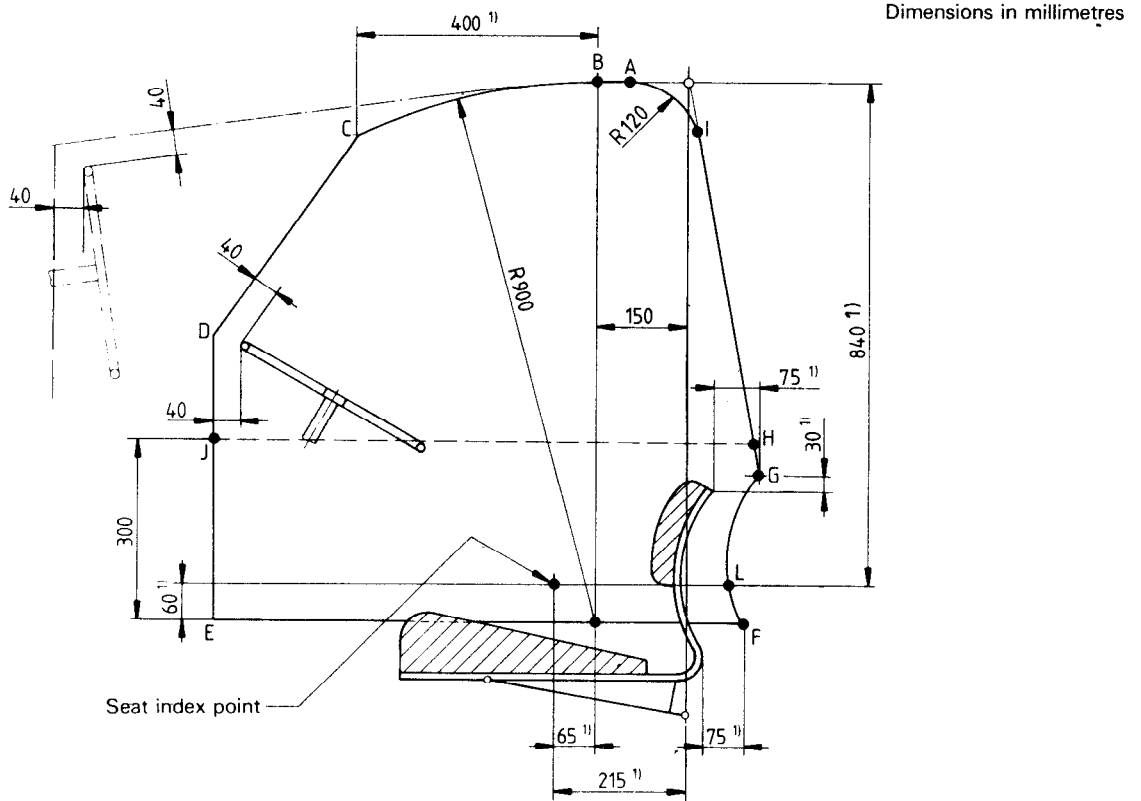

Annex A (normative)

Requirements for providing resistance to brittle fracture of protective structure at reduced operating temperature

The following requirements and procedure are intended to provide strength and resistance to brittle fracture at reduced temperature. It is suggested that the following minimum material requirements shall be met in judging the protective structure suitability at reduced operating temperature in those countries requiring this additional operating protection.

NOTE — The requirements and procedure in A.3 and A.4 are set forth as information until International Standards are developed.

A.1 Bolts and nuts used to attach the protective structure to the machine frame and to connect structural parts of the protective structure shall exhibit suitable controlled reduced temperature toughness properties.

A.2 All welding electrodes used in the fabrication of structural members and mounts shall be compatible with the protective structure material as given in A.3.

A.3 Steel materials for structural members of the protective structure shall be of controlled toughness material exhibiting minimum Charpy V-notch impact energy requirements as shown in table A.1.

NOTE — Steel with an as-rolled thickness less than 2,5 mm and with a carbon content less than 0,2 % is considered to meet this requirement.

Table A.1 — Minimum Charpy V-notch impact energy requirements for protective structure material at a specimen temperature of $-30\text{ }^{\circ}\text{C}$

Specimen size mm	Absorbed energy J
10 × 10	11
10 × 7,5	9,5
10 × 5	7,5
10 × 2,5	5,5

Structural members of the protective structure made from materials other than steel shall have equivalent low temperature impact resistance. Specimens shall be "longitudinal" and taken from flat stock, tubular or structural sections before forming or welding for use in the protective structure. Specimens from tubular or structural sections shall be taken from the middle of the biggest side and shall not include welds.

A.4 When testing the Charpy V-notch impact energy requirements, the specimen size shall be the largest of the sizes stated in the table that the material will permit.

The Charpy V-notch tests shall be made in accordance with the procedure in ASTM A 370¹⁾, except that specimen sizes shall be in accordance with the dimensions given in the table.

A.5 One alternative to this procedure is to use killed or semi-killed steel for which an adequate specification shall be provided.

1) The reference to ASTM A 370, *Standard methods and definitions for mechanical testing of steel products* will be replaced as soon as a corresponding International Standard becomes available.

Annex B
(normative)

Test report for protective structure

Name and address of protective structure manufacturer :

Submitted for test by :

Name and type of protective structure :

Make and model of tractor(s) on which tests were carried out :

Date of tests :

Test results

Loading tests were made to the left/right rear/front and to the right/left side. The reference mass, m_r , used for calculating energy input and crushing forces was : kg

Loading energies : rear/front : kJ
side : kJ

Crushing force : kN

Second longitudinal loading energy (made to right/left front/rear) : kJ

The acceptance conditions for these tests concerning clearance zone protection were/were not satisfactorily fulfilled.

Permanent deflections of protective structure extremities, measured after the series of tests¹⁾

- 1 Back : forwards/backwards
left : mm
right : mm
- 2 Front : forwards/backwards
left : mm
right : mm
- 3 Side : sideways
front : mm
rear : mm
- 4 Top : downwards/upwards
rear : left : mm
: right : mm
front : left : mm
: right : mm

The force—deflection curves formed during the tests shall be included.

Cold weather performance (resistance to brittle fracture)

If the manufacturer claims that his protective structure is suitable for cold temperature operation, state whether the test was carried out at a temperature of $-18\text{ }^\circ\text{C}$ or colder, or describe briefly the method used to identify resistance to brittle fracture at reduced temperature.

.....
.....
.....
.....

1) State the height on the protective structure at which these measurements were made, for example above the SIP.

Specification of tractor

Serial number :

Tractor mass, as defined in ISO 5700 : kg

Protective structure specification

- 1 Photographs, overall view and close-ups, showing mounting details.
- 2 General arrangement drawing.

Details of materials used in the construction of the protective structure

- 1 Main frame and cladding
 - material :
 - dimensions : mm
- 2 Mountings
 - material :
 - dimensions : mm
- 3 Roof
 - material :
 - dimensions : mm
- 4 Assembly and mounting bolts
 - grade :
 - dimensions : mm
- 5 Other items
 - material :
 - dimensions : mm

Standard Mark

The use of the Standard Mark is governed by the provisions of the *Bureau of Indian Standards Act, 1986* and the Rules and Regulations made thereunder. The Standard Mark on products covered by an Indian Standard conveys the assurance that they have been produced to comply with the requirements of that standard under a well defined system of inspection, testing and quality control which is devised and supervised by BIS and operated by the producer. Standard marked products are also continuously checked by BIS for conformity to that standard as a further safeguard. Details of conditions under which a licence for the use of the Standard Mark may be granted to manufacturers or producers may be obtained from the Bureau of Indian Standards.

Bureau of Indian Standards

BIS is a statutory institution established under the *Bureau of Indian Standards Act, 1986* to promote harmonious development of the activities of standardization, marking and quality certification of goods and attending to connected matters in the country.

Copyright

BIS has the copyright of all its publications. No part of these publications may be reproduced in any form without the prior permission in writing of BIS. This does not preclude the free use, in the course of implementing the standard, of necessary details, such as symbols and sizes, type or grade designation. Enquiries relating to copyright be addressed to the Director (Publications), BIS.

Revision of Indian Standards

Indian Standards are reviewed periodically and revised, when necessary and amendments, if any, are issued from time to time. Users of Indian Standards should ascertain that they are in possession of the latest amendments or edition. Comments on this Indian Standard may be sent to BIS giving the following reference:

Doc : No. FAD 32 (171) F

Amendments Issued Since Publication

Amend No.	Date of Issue	Text Affected

BUREAU OF INDIAN STANDARDS

Headquarters:

Manak Bhavan, 9 Bahadur Shah Zafar Marg, New Delhi 110002
Telephones : 331 01 31, 331 13 75

Telegrams : Manaksanstha
(Common to all Offices)

Regional Offices :

Central : Manak Bhavan, 9 Bahadur Shah Zafar Marg
NEW DELHI 110002

Telephone
{ 331 01 31
331 13 75

Eastern : 1/14 C. I. T. Scheme VII M, V. I. P. Road, Maniktola
CALCUTTA 700054

{ 37 84 99, 37 85 61,
37 86 26, 37 86 62

Northern : SCO 445-446, Sector 35-C, CHANDIGARH 160036

{ 53 38 43, 53 16 40,
53 23 84

Southern : C. I. T. Campus, IV Cross Road, MADRAS 600113

{ 235 02 16, 235 04 42,
235 15 19, 235 23 15

Western : Manakalaya, E9 MIDC, Marol, Andheri (East)
BOMBAY 400093

{ 632 92 95, 632 78 58,
632 78 91, 632 78 92

Branches : AHMADABAD, BANGALORE, BHOPAL, BHUBANESHWAR, COIMBATORE,
FARIDABAD, GHAZIABAD, GUWAHATI, HYDERABAD, JAIPUR, KANPUR,
LUCKNOW, PATNA, THIRUVANANTHAPURAM.