

Indian Standard

SPECIFICATION FOR
CALORIMETER FOR DETERMINATION OF
HEAT OF HYDRATION OF
HYDRAULIC CEMENT

UDC 666.94.015.427 : 536.664



© Copyright 1985

INDIAN STANDARDS INSTITUTION
MANAK BHAVAN, 9 BAHADUR SHAH ZAFAR MARG
NEW DELHI 110002

Indian Standard

SPECIFICATION FOR CALORIMETER FOR DETERMINATION OF HEAT OF HYDRATION OF HYDRAULIC CEMENT

Cement and Concrete Sectional Committee, BDC 2

<i>Chairman</i>	<i>Representing</i>
DR H. C. VISVESVARAYA	Cement Research Institute of India, New Delhi
<i>Members</i>	
ADDITIONAL DIRECTOR STANDARDS (B&S)	Research, Designs & Standards Organization (Ministry of Railways), Lucknow
DEPUTY DIRECTOR STANDARDS (B&S) (<i>Alternate</i>)	
SHRI K. P. BANERJEE	Larsen and Toubro Limited, Bombay
SHRI HARISH N. MALANI (<i>Alternate</i>)	
SHRI S. K. BANERJEE	National Test House, Calcutta
CHIEF ENGINEER (BD)	Bhakra Beas Management Board, Nangal Township
SHRI J. C. BASUR (<i>Alternate</i>)	
CHIEF ENGINEER (DESIGNS)	Central Public Works Department, New Delhi
EXECUTIVE ENGINEER (D) III (<i>Alternate</i>)	
CHIEF ENGINEER (RESEARCH- cum-DIRECTOR)	Irrigation and Power Research Institute, Government of Punjab, Amritsar
RESEARCH OFFICER (CONCRETE TECHNOLOGY) (<i>Alternate</i>)	
DIRECTOR	A. P. Engineering Research Laboratories, Hyderabad
JOINT DIRECTOR (<i>Alternate</i>)	
DIRECTOR	Central Soil and Materials Research Station, New Delhi
CHIEF RESEARCH OFFICER (<i>Alternate</i>)	
DIRECTOR (C&MDD-I)	Central Water Commission, New Delhi
DEPUTY DIRECTOR (C&MDD-I) (<i>Alternate</i>)	
SHRI V. K. GHANESKAR	Structural Engineering Research Centre (CSIR), Roorkee
SHRI A. V. GOKAK	Cement Controller (Ministry of Industry), New Delhi
SHRI S. S. MIGLANI (<i>Alternate</i>)	
SHRI A. K. GUPTA	Hyderabad Asbestos Cement Products Limited, Ballabgarh

(Continued on page 2)

© Copyright 1985

INDIAN STANDARDS INSTITUTION

This publication is protected under the *Indian Copyright Act* (XIV of 1957) and reproduction in whole or in part by any means except with written permission of the publisher shall be deemed to be an infringement of copyright under the said Act.

(Continued from page 1)

<i>Members</i>	<i>Representing</i>
SHRI P. J. JAGUS	Associated Cement Companies Ltd, Bombay
DR A. K. CHATTERJEE (<i>Alternate</i>)	
SHRI N. G. JOSHI	Indian Hume Pipes Co Limited, Bombay
SHRI R. L. KAPOOR	Ministry of Shipping and Transport (Roads Wing)
SHRI N. SIVAGURU (<i>Alternate</i>)	
SHRI S. K. LAHA	Institution of Engineers (India), Calcutta
SHRI B. T. UNWALLA (<i>Alternate</i>)	
DR A. K. MULLICK	Cement Research Institute of India, New Delhi
SHRI K. K. NAMBIAR	In personal capacity ('Ramanalaya' II, First Crescent Park Road, Gandhinagar, Adyar, Madras)
SHRI S. N. PAL	M. N. Dastur and Company Private Limited, Calcutta
SHRI BIMAN DASGUPTA (<i>Alternate</i>)	
SHRI H. S. PASRICHA	Hindustan Prefab Limited, New Delhi
SHRI Y. R. PHULL	Indian Roads Congress, New Delhi; and Central Road Research Institute (CSIR), New Delhi
SHRI M. R. CHATTERJEE (<i>Alternate</i>)	Central Road Research Institute (CSIR), New Delhi
DR MOHAN RAI	Central Building Research Institute (CSIR), Roorkee
DR S. S. REHSI (<i>Alternate</i>)	
DR M. RAMAIAH	Structural Engineering Research Centre (CSIR), Madras
DR A. G. MADHAVA RAO (<i>Alternate</i>)	
SHRI A. V. RAMANA	Dalmia Cement (Bharat) Limited, New Delhi
DR K. C. NARANG (<i>Alternate</i>)	
SHRI P. S. RAMACHANDRAN	India Cements Limited, Madras
SHRI G. RAMDAS	Directorate General of Supplies and Disposals, New Delhi
DR A. V. R. RAO	National Buildings Organization, New Delhi
SHRI J. SEN GUPTA (<i>Alternate</i>)	
SHRI R. V. CHALAPATHI RAO	Geological Survey of India, Calcutta
SHRI S. ROY (<i>Alternate</i>)	
SHRI T. N. SUBBA RAO	Gammon India Limited, Bombay
SHRI S. A. REDDI (<i>Alternate</i>)	
SHRI A. U. RIJHSINGHANI	Cement Corporation of India, New Delhi
SHRI C. S. SHARMA (<i>Alternate</i>)	
SHRI H. S. SATYANARAYANA	Engineer-in-Chief's Branch, Army Headquarters, New Delhi
SHRI V. R. KOTNIS (<i>Alternate</i>)	
SECRETARY	Central Board of Irrigation and Power, New Delhi
SHRI K. R. SAXENA (<i>Alternate</i>)	
SUPERINTENDING ENGINEER (DESIGNS)	Public Works Department, Government of Tamil Nadu, Madras
EXECUTIVE ENGINEER (SMD DIVISION) (<i>Alternate</i>)	
SHRI L. SWAROOP	Orissa Cement Limited, New Delhi
SHRI H. BHATTACHARYYA (<i>Alternate</i>)	
SHRI G. RAMAN, Director (Civ Engg)	Director General, ISI (<i>Ex-officio Member</i>)

Secretary

SHRI N. C. BANDYOPADHYAY
Deputy Director (Civ Engg), ISI

(Continued on page 9)

Indian Standard

SPECIFICATION FOR CALORIMETER FOR DETERMINATION OF HEAT OF HYDRATION OF HYDRAULIC CEMENT

0. FOREWORD

0.1 This Indian Standard was adopted by the Indian Standards Institution on 12 March 1985, after the draft finalized by the Cement and Concrete Sectional Committee had been approved by the Civil Engineering Division Council.

0.2 A number of standards on methods of testing cement and concrete has already been published. Having recognized that reliable and reproducible test results could be obtained only with use of standard testing equipment capable of giving desired level of accuracy, the Cement and Concrete Sectional Committee had taken up formulation of Indian Standards on instruments for testing cement and concrete and, as a result, a number of Indian Standards on instruments for testing cement and concrete have already been published. These standards are expected to promote development and manufacture of standard testing equipment in the country.

0.3 Accordingly, this standard has been formulated to cover the requirements of calorimeter and its accessories used for determination of heat of hydration of hydraulic cement. The method for determination of heat of hydration of hydraulic cement is covered in IS : 4031-1968*.

0.4 In the formulation of this standard, due weightage has been given to international coordination among the standards and practices prevailing in different countries in addition to relating it to the practices in the field in this country.

0.5 For the purpose of deciding whether a particular requirement of this standard is complied with, the final value, observed or calculated, expressing the result of a test or analysis, shall be rounded off in accordance with IS : 2-1960†. The number of significant places retained in the rounded off value should be the same as that of the specified value in this standard.

*Methods of physical tests for hydraulic cement.

†Rules for rounding off numerical values (*revised*).

1. SCOPE

1.1 This standard covers the requirements of the calorimeter and its accessories used for the determination of heat of hydration of hydraulic cement.

2. MATERIALS

2.1 Materials of construction of different components of the apparatus shall be as given in Table 1.

TABLE 1 MATERIALS OF CONSTRUCTION OF DIFFERENT COMPONENTS

SL No.	COMPONENT	MATERIAL	SPECIFIC REQUIREMENT AND RECOMMENDATION
(1)	(2)	(3)	(4)
i)	Calorimeter	Vacuum flask — Glass	—
ii)	Insulated container	Wooden and insulating material like cork, cotton wool or similar material	—
iii)	Thermometer	Beckmann	—
iv)	Stirrer	Glass or polyethylene	—
v)	Stirrer motor	—	40 W synchronous motor geared to run at constant speed in the range of 350 to 700 rev/min
vi)	Funnel	Glass or polyethylene	—

3. WORKING PRINCIPLE

3.1 The calorimeter consists of a vacuum flask fitted in an insulated container, Beckmann thermometer, stirrer assembly and a funnel. The heat of hydration of hydraulic cement is determined by measuring the heat of solution of dry cement and the heat of solution of a separate portion of the cement that has been partially hydrated for any specific period; the difference between these values being the heat of hydration for that specified period (*see* IS : 4031-1968*).

4. APPARATUS

4.1 Calorimeter — The calorimeter (*see* Fig. 1) shall consist of a 450 ml (approximately 150 mm × 70 mm dia) capacity wide-mouthed vacuum flask with a cork stopper, 40 mm thick.

*Methods of physical tests for hydraulic cement.

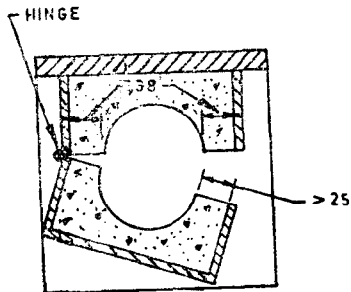
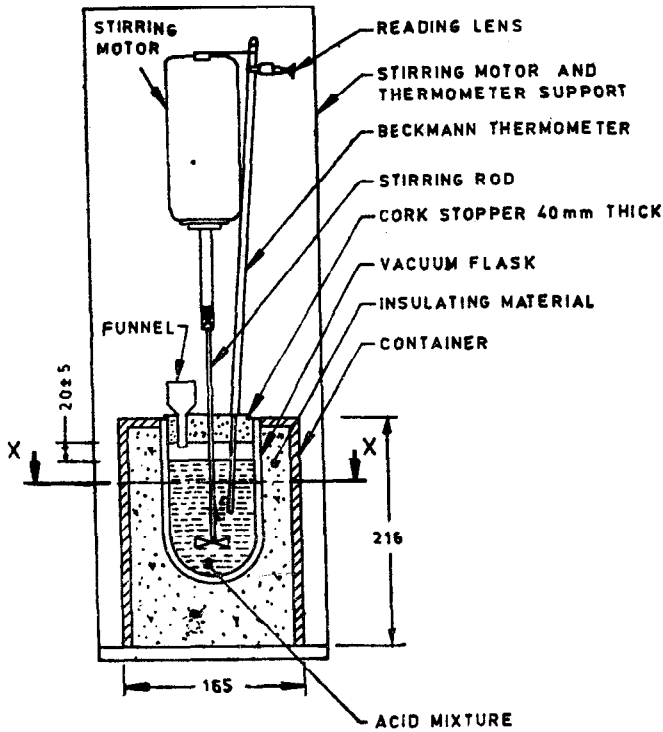

SECTION XX

All dimensions in millimetres.

FIG. 1 CALORIMETER

The flask shall be selected as follows:

- a) when filled with 398 ml of water, the water surface is 20 ± 6.5 mm below the lower surface of the bung (cork stopper).
- b) When the flask is filled with 400 ml of warm water, the temperature loss per minute per degree Celsius above room temperature determined after standing without stirring for half an hour, does not exceed 0.002°C per min per degree Celsius excess temperature.

The whole inner surface of the vacuum flask and underside of the cork stopper is evenly and thinly coated with material resistant to hydrofluoric acid, such as paraffin wax having congealing point about 60°C forming an acid-proof lining. The acid resistant coating shall be intact and free of cracks at all times. Should the lining at any time become damaged, as indicated by an unusual temperature rise during the determination of the initial heating or cooling correction, the whole lining shall be melted off and renewed.

4.2 Insulated Container — The wooden container shall have an insulating layer of cork, cotton wool or similar material at least 25 mm thick, completely enclosing the flask and also providing support for the flask and the stirrer motor. The container shall be divided in a vertical plane into two parts which are hinged together on one side and provided with a fastening device on the other so as to permit easy removal of the vacuum flask.

4.3 Differential and Reference Thermometers — The adjustable differential thermometer shall be of Beckmann type, graduated at least to 0.01°C and shall have a range of approximately 6°C . The portion of the thermometer that will rest inside the calorimeter shall be protected with a coating resistant to hydrofluoric acid. The thermometer shall be provided with a suitable reading lens. It shall be securely held by the cork stopper so as to avoid accidental contact with the stirrer blades. In order to facilitate removal of the thermometer, the cork stopper may be divided into two halves, one of which supports the thermometer, and the other the funnel.

The reference thermometer shall be of the appropriate range with 0.1°C graduations.

4.4 Stirring Assembly — The stirrer (see Fig. 2) shall be made of glass or polyethylene, of the double-bladed propeller type, approximately 40 mm in diameter and shall extend to within 40 mm of the bottom of the flask. It shall have shaft diameter of 6 mm and shaft length of 400 mm. When a glass stirrer is used, the portion that will be inside the calorimeter shall be protected with a coating resistant to hydrofluoric acid. The pitch of the blades is set in such a manner that when the

stirrer is actuated by the drive motor, liquid in the flask is propelled in a downward direction. Means shall be provided for disconnecting the stirrer from the motor which shall be 40 Watts synchronous motor geared to run at a constant speed in the range of 350 to 700 rev/min.

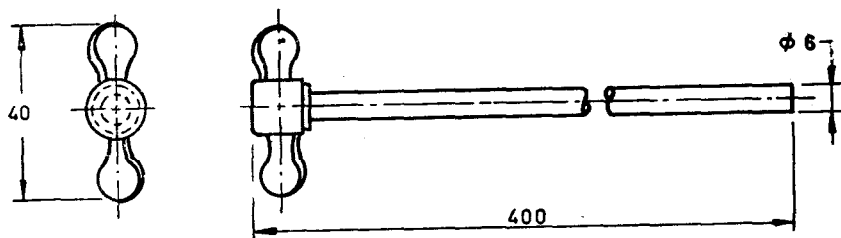

All dimensions in millimetres.

FIG. 2 STIRRER

The heat developed by the stirrer when running continuously shall be such that the contents of the flask shall not rise in temperature at a rate greater than $0.001^{\circ}\text{C}/\text{min}$ over and above the rate of temperature change in the unstirred condition.

NOTE — The function of the stirrer is two-fold (a) to maintain uniform temperature throughout the liquid and (b) to supply sufficient agitation to keep the solid in suspension in the acid mixture. Since a stirrer capable of keeping the solid in suspension generates considerable heat in the calorimeter, it is important that the stirrer speed and hence the rate of heat generation be maintained constant. A synchronous motor and a geared speed reducer are almost mandatory.

4.5 Funnel — The funnel through which the sample is introduced into the calorimeter shall be of the Gooch type made of glass or polyethylene and shall have a stem of 6 mm internal diameter and a body approximately 25 mm long and 25 mm in diameter. The stem shall not protrude more than 3 mm beneath the cork stopper.

5. MARKING

5.1 The following information shall be clearly and indelibly marked on each component of the apparatus, as far as practicable, in such a way that it does not interfere with the performance of the apparatus:

- a) Name of the manufacturer or his registered trade-mark or both, and
- b) Date of manufacture.

5.1.1 The apparatus may also be marked with the ISI Certification Mark.

NOTE — The use of the ISI Certification Mark is governed by the provisions of the Indian Standards Institution (Certification Marks) Act and the Rules and Regulations made thereunder. The ISI Mark on products covered by an Indian Standard conveys the assurance that they have been produced to comply with the requirements of that standard under a well-defined system of inspection, testing and quality control which is devised and supervised by ISI and operated by the producer. ISI marked products are also continuously checked by ISI for conformity to that standard as a further safeguard. Details of conditions under which a licence for the use of the ISI Certification Mark may be granted to manufacturers or processors, may be obtained from the Indian Standards Institution.

(Continued from page 2)

Instruments for Cement and Concrete Testing Subcommittee,
BDC 2 : 10

Convener

DR IQBAL ALI
14-1-359, New Aghapura, Hyderabad

Members

Representing

SHRI P. D. AGARWAL	Public Works Department, Government of Uttar Pradesh, Lucknow
DR T. N. CHOJER (<i>Alternate</i>)	
SHRI S. K. BANERJEE	National Test House, Calcutta
DR R. K. DATTA	Central Building Research Institute (CSIR), Roorkee
SHRI J. P. KAUSHISH (<i>Alternate</i>)	
DIRECTOR	A. P. Engineering Research Laboratories, Hyderabad
JOINT DIRECTOR (<i>Alternate</i>)	
EXECUTIVE ENGINEER (D) V	Central Public Works Department, New Delhi
SHRI H. K. GUHA	All India Instrument Manufacturers and Dealers Association, Bombay
DEPUTY SECRETARY (<i>Alternate</i>)	
SHRI JATINDER SINGH	Hydraulic Engineering Instruments, New Delhi
SHRI GURBACHAN SINGH (<i>Alternate</i>)	
SHRI M. R. JOSHI	Research & Development Organization (Ministry of Defence), New Delhi
SHRI Y. P. PATHAK (<i>Alternate</i>)	
PROF S. KRISHNAMURTHY	Indian Institute of Technology, New Delhi
SHRI P. S. PARAMESWARAN	Associated Cement Companies Ltd, Bombay
SHRI B. V. B. PAI (<i>Alternate</i>)	
PROF C. K. RAMESH	Indian Institute of Technology, Bombay
DR R. S. AYYAR (<i>Alternate</i>)	
DR V. V. SUBBA RAO	Cement Research Institute of India, New Delhi
SHRI N. K. JAIN (<i>Alternate I</i>)	
SHRI K. H. BABU (<i>Alternate II</i>)	
SHRI C. SANKARAN	Highways Research Station, Madras
SHRI A. V. S. R. SASTRI	Associated Instrument Manufacturers (India) Pvt Ltd, New Delhi; and Advisory Committee for Standardization of Instruments (ACSI), New Delhi
SHRI PALVINDER SINGH (<i>Alternate</i>)	
SHRI S. S. SEEHRA	Central Road Research Institute, New Delhi
DR P. ROY CHAUDHURI (<i>Alternate I</i>)	
SHRI HARJIT SINGH (<i>Alternate II</i>)	

INTERNATIONAL SYSTEM OF UNITS (SI UNITS)

Base Units

QUANTITY	UNIT	SYMBOL
Length	metre	m
Mass	kilogram	kg
Time	second	s
Electric current	ampere	A
Thermodynamic temperature	kelvin	K
Luminous intensity	candela	cd
Amount of substance	mole	mol

Supplementary Units

QUANTITY	UNIT	SYMBOL
Plane angle	radian	rad
Solid angle	steradian	sr

Derived Units

QUANTITY	UNIT	SYMBOL	DEFINITION
Force	newton	N	1 N = 1 kg.m/s ²
Energy	joule	J	1 J = 1 N.m
Power	watt	W	1 W = 1 J/s
Flux	weber	Wb	1 Wb = 1 V.s
Flux density	tesla	T	1 T = 1 Wb/m ²
Frequency	hertz	Hz	1 Hz = 1 c/s (s ⁻¹)
Electric conductance	siemens	S	1 S = 1 A/V
Electromotive force	volt	V	1 V = 1 W/A
Pressure, stress	pascal	Pa	1 Pa = 1 N/m ²