

REAFFIRMED

Indian Standard

SPECIFICATION FOR EQUIPMENT FOR
DETERMINATION OF LIQUID LIMIT OF
SOILS CONE PENETRATION METHOD

UDC 624.131.439.83 : 620.1.05



© Copyright 1985

INDIAN STANDARDS INSTITUTION
MANAK BHAVAN, 9 BAHADUR SHAH ZAFAR MARG
NEW DELHI 110002

Indian Standard

SPECIFICATION FOR EQUIPMENT FOR DETERMINATION OF LIQUID LIMIT OF SOILS CONE PENETRATION METHOD

Soil Engineering Sectional Committee, BDC 23

Chairman

SHRI SHAMSHER PRAKASHI

*Representing*Central Building Research Institute (CSIR)
Roorkee*Members*

PROF ALAM SINGH

University of Jodhpur, Jodhpur

SHRI B. ANJIAH

Engineering Research Laboratories, Government of
Andhra Pradesh, Hyderabad

CHIEF ENGINEER (IPRI)

Irrigation Department, Government of Punjab,
ChandigarhDIRECTOR (DAM) (*Alternate*)

SHRI C. S. DARKE

Howe (India) Pvt Ltd, New Delhi

SHRI G. V. MURTHY (*Alternate*)

SHRI A. G. DASTIDAR

In personal capacity (5 Hungerford Court 12/1
Hungerford Street, Calcutta)

DIRECTOR (D & QPC)

Public Works Department, Government of Uttar
Pradesh, LucknowDEPUTY DIRECTOR (B & SD) (*Alternate*)

DIRECTOR, IRI

Irrigation Department, Government of Uttar
Pradesh, Roorkee

SHRI A. H. DIVANJI

Asia Foundations and Construction (P) Ltd, Bombay

SHRI A. N. JANGLE (*Alternate*)

DIRECTOR

Central Soil & Materials Research Station, New
DelhiDEPUTY DIRECTOR (*Alternate*)

DR GOPAL RANJAN

University of Roorkee, Roorkee; and Institute of
Engineers (India), Calcutta

SHRI S. GUPTA

Cemindia Company Limited, Bombay

SHRI N. V. DE-SOUZA (*Alternate*)

SHRI M. IYENGAR

Engineers India Limited, New Delhi

SHRI ASHOK K. JAIN

G. S. Jain and Associates, New Delhi

SHRI VIJAY K. JAIN (*Alternate*)

JOINT DIRECTOR RESEARCH Ministry of Railways

(GE)-I, RDSO

JOINT DIRECTOR RESEARCH

(GE)-II, RDSO (*Alternate*)

(Continued on page 2)

© Copyright 1985

INDIAN STANDARDS INSTITUTION

This publication is protected under the *Indian Copyright Act* (XIV of 1957) and reproduction in whole or in part by any means except with written permission of the publisher shall be deemed to be an infringement of copyright under the said Act.

(Continued from page 1)

<i>Members</i>	<i>Representing</i>
SHRI A. V. S. R. MURTY SHRI D. R. NARAHARI	Indian Geotechnical Society, New Delhi Central Building Research Institute (CSIR), Roorkee
SHRI V. S. AGARWAL (Alternate) SHRI T. K. NATRAJAN	Central Road Research Institute (CSIR), New Delhi
SHRI RANJIT SINGH SHRI V. B. GHORPADE (Alternate)	Ministry of Defence (R & D)
DR G. V. RAO DR K. K. GUPTA (Alternate)	Indian Institute of Technology, New Delhi
RESEARCH OFFICER (B & RRL)	Public Works Department, Government of Punjab, Chandigarh
SECRETARY DIRECTOR (C) (Alternate)	Central Board of Irrigation and Power, New Delhi
SHRI N. SIVAGURU SHRI U. JAYAKODI (Alternate)	Ministry of Shipping and Transport (Road Wing)
SHRI K. S. SRINIVASAN SHRI SUNIL BERRY (Alternate)	National Buildings Organization, New Delhi
DR N. SOM SHRI N. SUBRAMANYAM	Jadavpur University, Calcutta Karnataka Engineering Research Station, Krishnarajasagar
COL R. R. SUDHINDRA SHRI S. S. JOSHI (Alternate)	Ministry of Defence (Engineer-in-Chief's Branch)
SUPERINTENDING ENGINEER (P & DC) EXECUTIVE ENGINEER (SMRD) (Alternate)	Public Works Department, Government of Tamil Nadu, Madras
SHRI H. C. VERMA SHRI H. K. GUHA (Alternate)	All India Instrument Manufacturers and Dealers Association, Bombay
SHRI G. RAMAN, Director (Civ Engg)	Director General, ISI (Ex-officio Member)

Secretary

SHRI K. M. MATHUR
Senior Deputy Director (Civ Engg) ISI

Soil Testing Instruments and Equipment Subcommittee, BDC 23 : 6

Convener

SHRI H. C. VERMA Associated Instrument Mfrs (I) Pvt Ltd, New Delhi

Members

SHRI M. D. NAIR (Alternate to
Shri H. C. Verma) Saraswati Engineering Agency, Roorkee

SHRI AMED KRISHNA
SHRI RAKESH GOEL (Alternate)

DEPUTY DIRECTOR RESEARCH Ministry of Railways
(GE)-III

JOINT DIRECTOR RESEARCH
(GE)-II (Alternate)

(Continued on page 16)

Indian Standard

SPECIFICATION FOR EQUIPMENT FOR DETERMINATION OF LIQUID LIMIT OF SOILS CONE PENETRATION METHOD

0. FOREWORD

0.1 This Indian Standard was adopted by the Indian Standards Institution on 25 January 1985, after the draft finalized by the Soil Engineering Sectional Committee had been approved by the Civil Engineering Division Council.

0.2 The Indian Standards Institution has already published a series of standards on methods of testing soils. It has been recognized that reliable and intercomparable test results can be obtained only with standard testing equipment capable of giving the desired level of accuracy. The Sectional Committee has, therefore, decided to bring out a series of specifications covering the requirements of equipment used for testing soils to encourage its development and manufacture in the country.

0.3 The equipment covered in this standard is used for determination of liquid limit of soil by cone penetration method as covered in IS : 2720 (Part 5)-1985*.

0.4 In reporting the result of a test or analysis made in accordance with this standard, if the final value, observed or calculated, is to be rounded off, it shall be done in accordance with IS : 2-1960†.

1. SCOPE

1.1 This standard covers the details of apparatus for determination of liquid limit of soils by cone penetration method.

2. DIMENSIONS

2.1 Dimensions with tolerances of different component parts of the equipment shall be as detailed in Fig. 1 to 9. Except where tolerances are specially mentioned against the dimensions, all dimensions shall be taken as nominal and tolerances of medium class as given in IS : 2102 (Part 1)-1980‡ shall apply.

*Methods of the test for soils : Part 5 Determination of liquid and plastic limits (second revision).

†Rules for rounding off numerical values (revised).

‡General tolerances for dimensions, and form and position: Part 1 General tolerances for linear and angular dimensions (second revision).

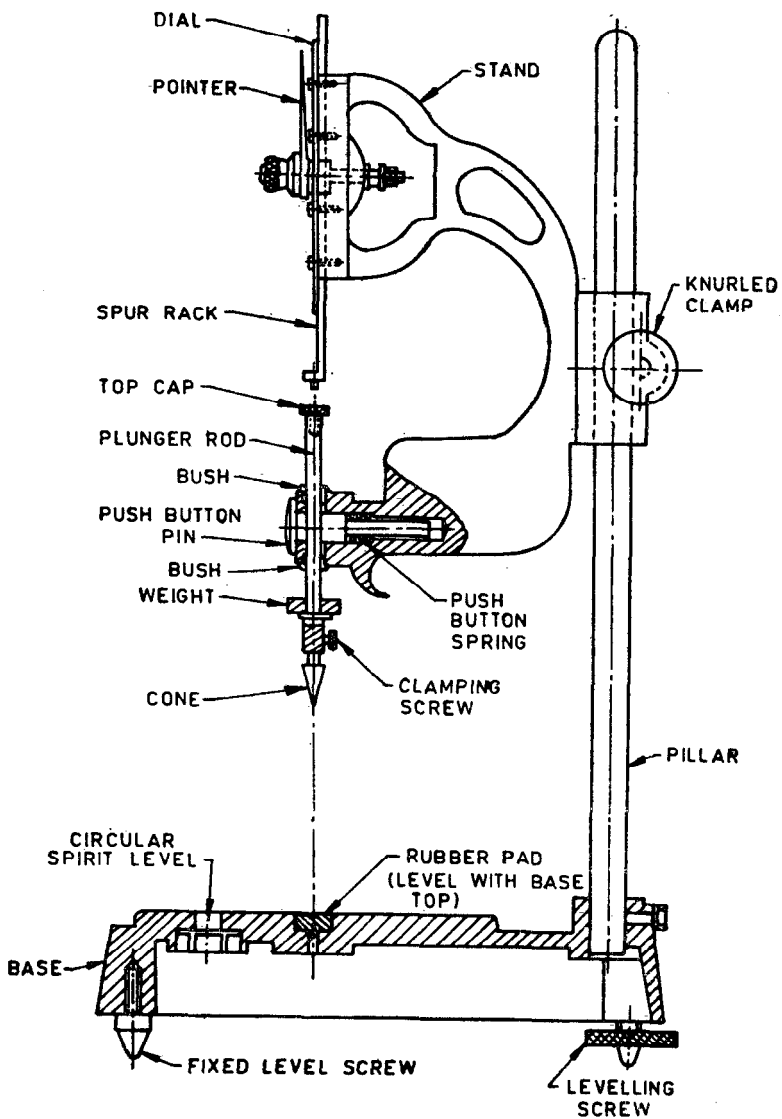
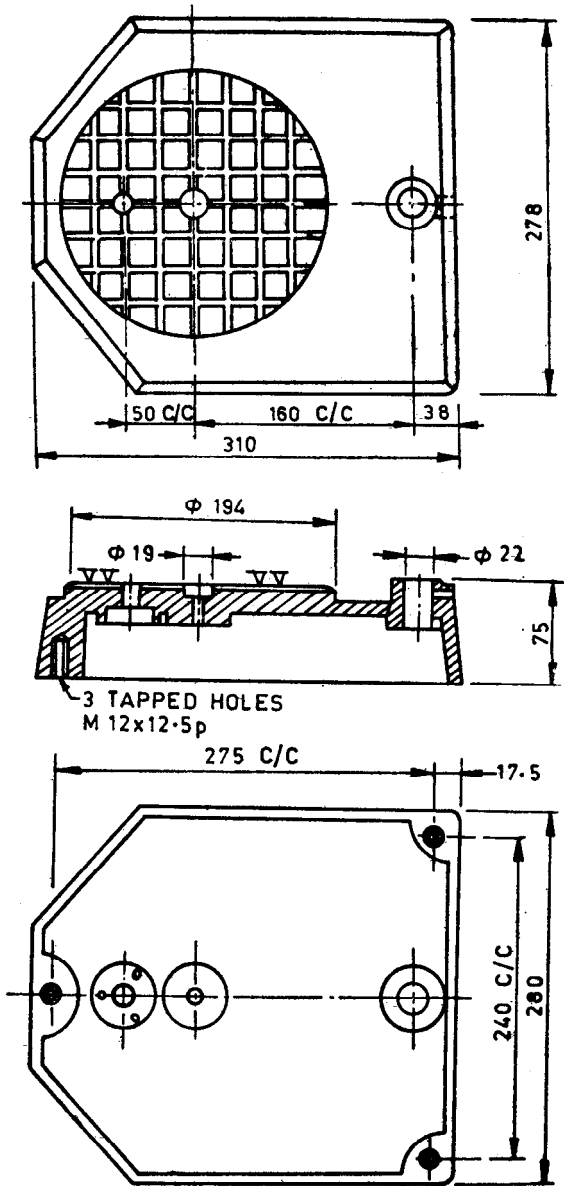

FIG. 1 GENERAL ASSEMBLY



2 A BASE BODY

All dimensions in millimetres.

FIG. 2 BASE BODY — Contd

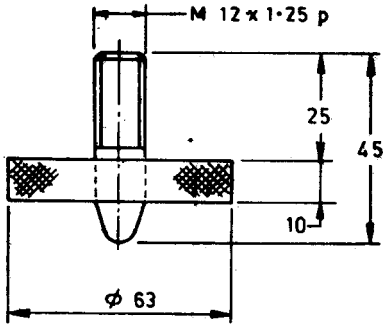

2B LEVELLING SCREW

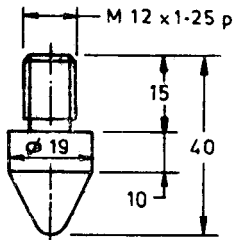

2C FIXED LEVEL SCREW

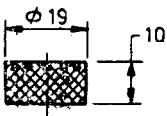

2D RUBBER PAD

All dimensions in millimetres.

FIG. 2 BASE BODY

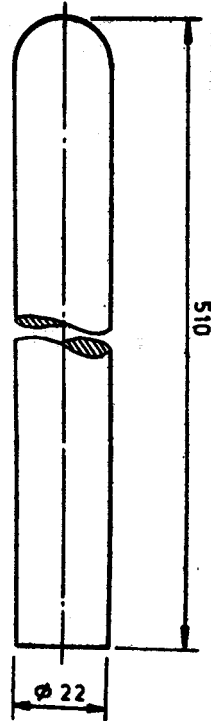

All dimensions in millimetres.

FIG. 3 PILLAR

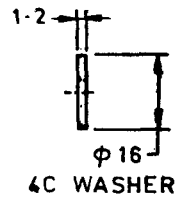
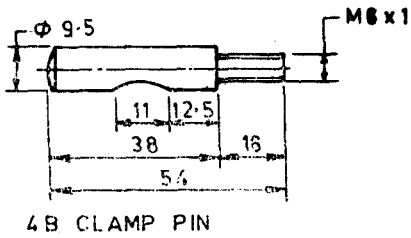
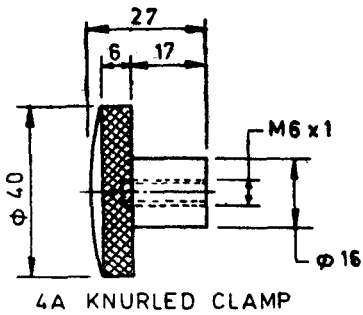
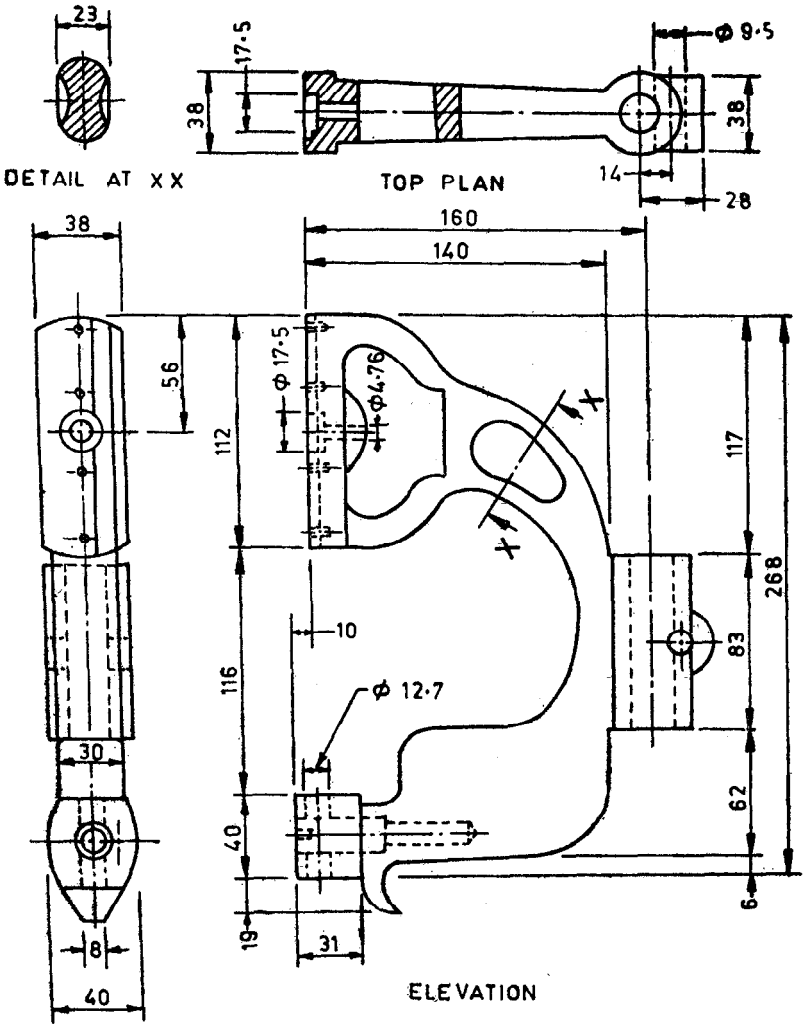
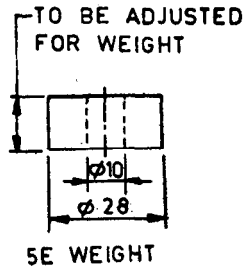
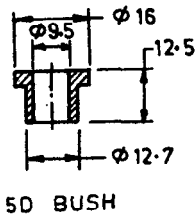
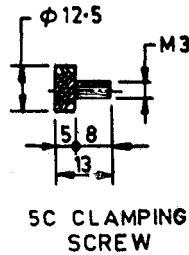
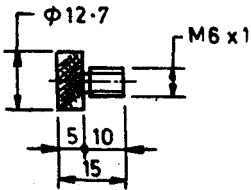
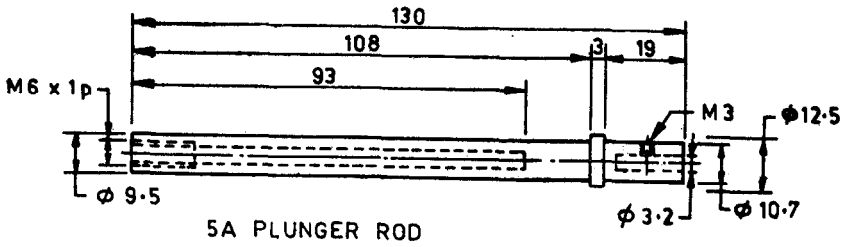

FIG. 4 BRACKET — Contd



All dimensions in millimetres.

FIG. 4 BRACKET



All dimensions in millimetres.

FIG. 5 PLUGNER

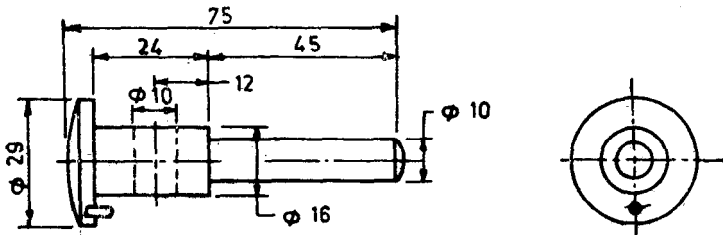

6A BUSH BUTTON PIN



SPRING DATA

O.D. $\phi 15$
TOTAL LENGTH 28
No OF COILS 8
WIRE DIA 1.5
6B PUSH BUTTON SPRINGS

All dimensions in millimetres.

FIG. 6 RELEASE MECHANISM

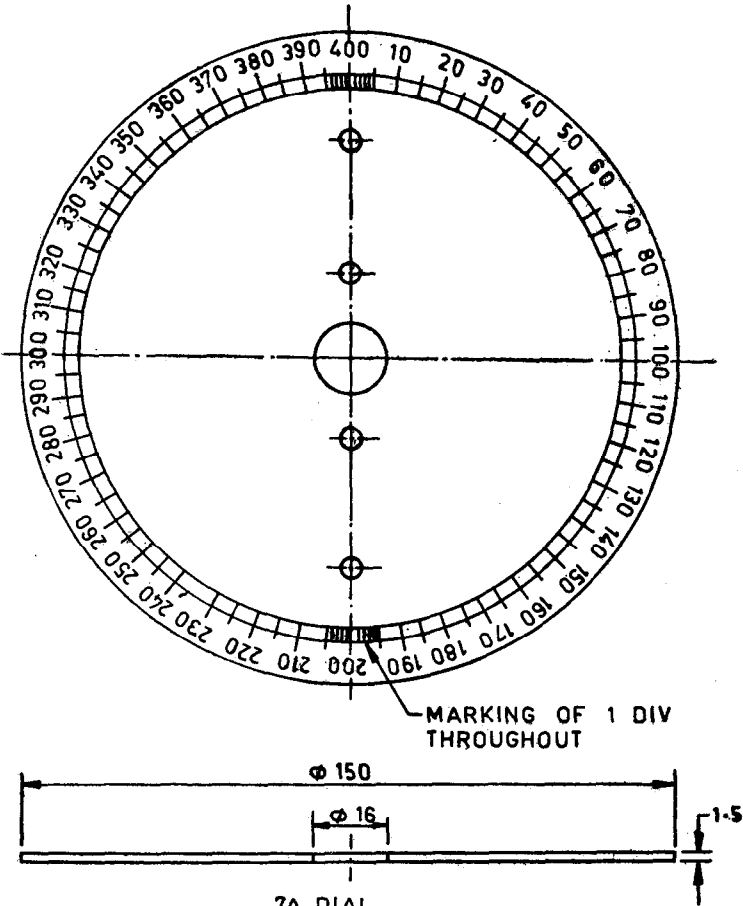

All dimensions in millimetres.

FIG. 7 DIAL GAUGE — Contd

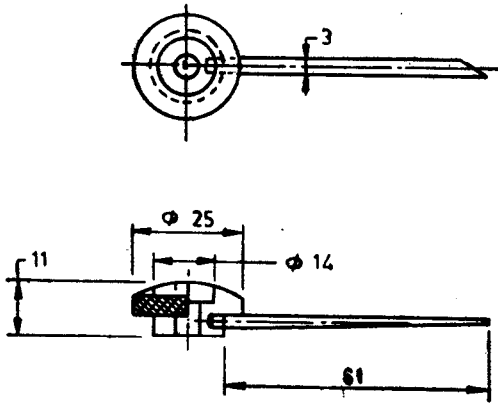

7B NEEDLE POINTER

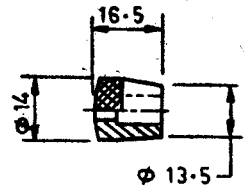

7C POINTER BUSH

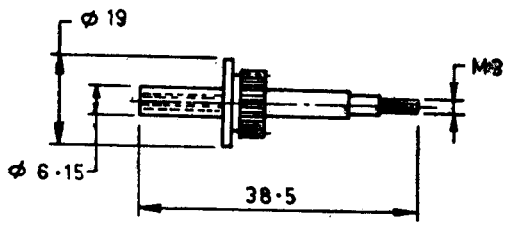

7D PINION SHAFT

FIG. 7 DIAL GAUGE

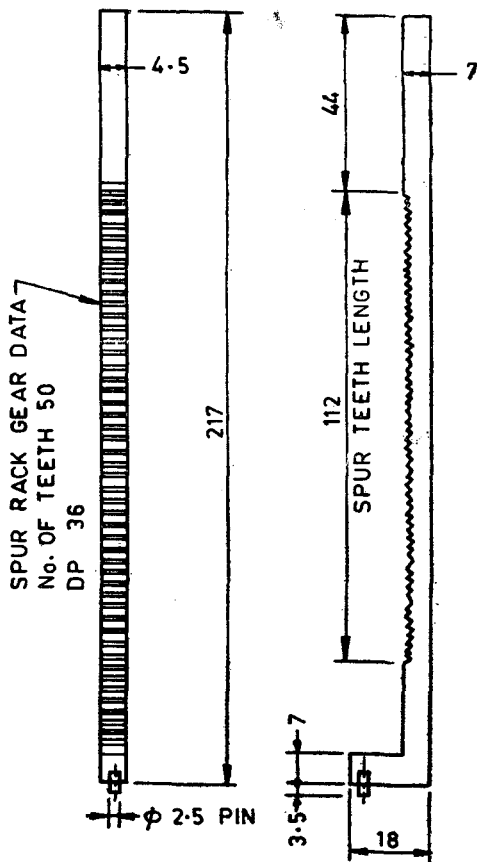

All dimensions in millimetres.

FIG. 8 SPUR RACK

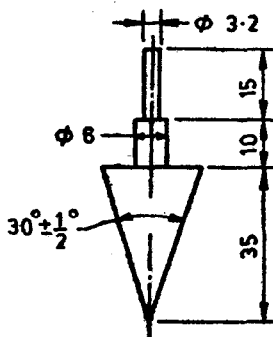

All dimensions in millimetres.

FIG. 9 CONE

3. MATERIALS

3.1 The materials of construction of various component parts of the equipment shall be as given in Table 1.

4. CONSTRUCTION

4.1 The base, pillar, bracket, plunger, release mechanism, dial rack and cone shall be according to details given in Fig. 1 to 9. The mass of plunger along with its components and cone as given in Fig. 5 and Fig. 9 shall be 80 ± 0.5 g (for this purpose thickness of weight given in Fig. 5E be adjusted) and when assembled the pin fixed at the bottom of the rack shall be in line and concentric with the plunger assembly.

5. MARKING

5.1 The following information shall be clearly and indelibly marked suitably on each part:

- a) Name of manufacturer, and
- b) Date of manufacture.

5.1.1 The equipment may also be marked with the ISI Certification Mark.

NOTE — The use of the ISI Certification Mark is governed by the provisions of the Indian Standards Institution (Certification Marks) Act and the Rules and Regulations made thereunder. The ISI Mark on products covered by an Indian Standard conveys the assurance that they have been produced to comply with the requirements of that standard under a well-defined system of inspection, testing and quality control which is devised and supervised by ISI and operated by the producer. ISI marked products are also continuously checked by ISI for conformity to that standard as a further safeguard. Details of conditions under which a licence for the use of the ISI Certification Mark may be granted to manufacturers or processors, may be obtained from the Indian Standards Institution.

TABLE 1 MATERIALS OF CONSTRUCTION OF VARIOUS COMPONENT PARTS

(Clause 3.1)

SL No.	COMPONENTS PARTS	MATERIAL	SPECIAL REQUIREMENT	RELEVANT IS NUMBER
i)	Base body	Cast aluminium		IS : 617-1975*
ii)	Levelling screws	Mild steel	Nickel/Chrome plated	IS : 1875-1978†
iii)	Pillar	Mild steel	Nickel/Chrome plated	IS : 1875-1978†
iv)	Bracket	Cast aluminium		IS : 617-1975*
v)	Knurled clamp	Mild steel	Nickel/Chrome plated	IS : 1875-1978†
vi)	Clamp pin	Mild steel	Nickel/Chrome plated	IS : 1875-1978†
vii)	Plunger rod	Mild steel	Nickel/Chrome plated	IS : 1875-1978†
viii)	Top cap	Mild steel	Nickel/Chrome plated	IS : 1875-1978†
ix)	Clamping screw	Mild steel	Nickel/Chrome plated	IS : 1875-1978†
x)	Bush	Brass	—	IS : 4170-1967‡
xi)	Weight	Brass		IS : 4170-1967‡
xii)	Push button pin	Mild steel	Nickel/Chrome plated	IS : 1875-1978†
xiii)	Push button spring	Spring steel	Nickel/Chrome plated	IS : 4454 (Part I)-1975§
xiv)	Dial	Aluminium	Anodized	IS : 7883-1975
xv)	Needle pointer	Mild steel	Nickel/Chrome plated	IS : 1875-1978†
xvi)	Pointer bush	Brass	—	IS : 4170-1967‡
xvii)	Pinion shaft	Mild steel	Nickel/Chrome plated	IS : 1875-1978†
xviii)	Spur rack	Mild steel	Nickel/Chrome plated	IS : 1875-1978†
xix)	Cone	Stainless steel	—	IS : 6603-1972¶

*Specification for aluminium and aluminium alloy ingots and castings for general engineering purposes (*second revision*).

†Specification for carbon steel billets, blooms, slabs and bars for forgings (*fourth revision*).

‡Specification for brass rods for general engineering purposes.

§Specification for steel wires for cold formed springs: Part 1 Patented and cold drawn steel wires — unalloyed (*second revision*).

||Specification for aluminium-manganese alloy sheet and strip for aircraft purposes (alloy No. 31000).

¶Specification for stainless steel bars and flats.

IS : 11196 - 1985

(Continued from page 2)

<i>Members</i>	<i>Representing</i>
DIRECTOR (CSMRS)	Central Soil & Materials Research Station, New Delhi
DEPUTY DIRECTOR (CSMRS) (<i>Alternate</i>)	
SHRI H. K. GUHA	Geologists Syndicate Pvt Ltd, Calcutta
SHRI A. BHATTACHARYA (<i>Alternate</i>)	
DR S. C. HANDA	University of Roorkee, Roorkee
SHRI P. K. JAIN (<i>Alternate</i>)	
SHRI VIJAY K. JAIN	G. S. Jain Associates, New Delhi
DR B. R. MALHOTRA	Central Road Research Institute (CSIR), New Delhi
SHRI S. K. MITRA	K. N. Dadina Foundation Engineers, Calcutta
BRIG M. K. PAUL	Ministry of Defence
SHRI M. P. SHUKLA (<i>Alternate</i>)	
DR T. RAMAMURTHY	Indian Institute of Technology, Delhi
SHRI RESHAM SINGH	Hydraulic & Engineering Instruments Company, New Delhi
SHRI JATINDER SINGH (<i>Alternate</i>)	
SHRI S. VENKATESAN	Central Building Research Institute (CSIR), Roorkee
SHRI M. R. SENEJA (<i>Alternate</i>)	