

IS : 10890 - 1984

*Indian Standard*

SPECIFICATION FOR  
PLANETARY MIXER USED IN TESTS OF  
CEMENT AND POZZOLANA

UDC 666'94/'95 : 620'173



© Copyright 1984

INDIAN STANDARDS INSTITUTION  
MANAK BHAVAN, 9 BAHADUR SHAH ZAFAR MARG  
NEW DELHI 110002

*Indian Standard*

**SPECIFICATION FOR  
PLANETARY MIXER USED IN TESTS OF  
CEMENT AND POZZOLANA**

**Cement and Concrete Sectional Committee, BDC 2**

*Chairman*

DR H. C. VISVESVARAYA

*Representing*

Cement Research Institute of India, New Delhi

*Members*

ADDITIONAL DIRECTOR, STANDARDS ( B & S )	Research, Designs & Standards Organization ( Ministry of Railways ), Lucknow
DEPUTY DIRECTOR, STANDARDS ( B & S ) ( <i>Alternate</i> )	
SHRI K. P. BANERJEE	Larsen & Toubro Ltd, Bombay
SHRI HARISH N. MALANI ( <i>Alternate</i> )	
SHRI S. K. BANERJEE	National Test House, Calcutta
DR N. S. BHAL	Structural Engineering Research Centre ( CSIR ), Roorkee
SHRI V. K. GHANEKAR ( <i>Alternate</i> )	
SHRI S. P. CHAKRABORTI	Roads Wing, Ministry of Shipping and Transport, New Delhi
SHRI N. SHIVAGURU ( <i>Alternate</i> )	
CHIEF ENGINEER ( DESIGNS )	Central Public Works Department, New Delhi
EXECUTIVE ENGINEER ( DESIGNS ) III ( <i>Alternate</i> )	
CHIEF ENGINEER ( BD )	Beas Designs Organization, Nangal Township
SHRI T. C. BASUR ( <i>Alternate</i> )	
CHIEF ENGINEER ( RESEARCH )-CUM- DIRECTOR	Irrigation Department, Government of Punjab, Chandigarh
RESEARCH OFFICER ( IPRI ) ( <i>Alternate</i> )	
DR S. K. CHOPRA	Cement Research Institute of India, New Delhi
DR A. K. MULLICK ( <i>Alternate</i> )	
DIRECTOR	A. P. Engineering Research Laboratories, Hyderabad
DIRECTOR ( C & MDD-I )	Central Water Commission, New Delhi
DEPUTY DIRECTOR ( C & MDD-I ) ( <i>Alternate</i> )	
DIRECTOR	Central Soil & Materials Research Station, New Delhi
DEPUTY DIRECTOR ( <i>Alternate</i> )	
SHRI T. A. E. D'SA	The Concrete Association of India, Bombay
SHRI N. C. DUGGAL ( <i>Alternate</i> )	
SHRI A. V. GOKAK	Cement Controller ( Ministry of Industry )
SHRI S. S. MIGLANI ( <i>Alternate</i> )	

( *Continued on page 2* )

© Copyright. 1984

INDIAN STANDARDS INSTITUTION

This publication is protected under the *Indian Copyright Act (XIV of 1957)* and reproduction in whole or in part by any means except with written permission of the publisher shall be deemed to be an infringement of copyright under the said Act.

IS : 10890 - 1984

( Continued from page 1 )

<i>Members</i>	<i>Representing</i>
SHRI A. K. GUPTA	Hyderabad Asbestos Cement Products Ltd, Hyderabad
SHRI N. G. JOSHI	Indian Hume Pipes Company Ltd, Bombay
SHRI P. J. JAGUS	The Associated Cement Companies Ltd, Bombay
SHRI M. R. VINAYAKA ( <i>Alternate</i> )	M. N. Dastur & Co Pvt Ltd, Bombay
SHRI S. R. KULKARNI	The Institution of Engineers ( India ), Calcutta
SHRI S. K. LAHA	
SHRI B. T. UNWALLA ( <i>Alternate</i> )	Hindustan Prefab Ltd, New Delhi
SHRI G. K. MAJUMDAR	
SHRI H. S. PASRICHA ( <i>Alternate</i> )	In personal capacity ( 'RamanaIaya' II First Crescent Park Road, Gandhinagar, Adyar, Madras )
SHRI K. K. NAMBIAR	Indian Roads Congress, New Delhi; and Central Road Research Institute ( CSIR ), New Delhi
SHRI Y. R. PHULL	Central Road Research Institute ( CSIR ), New Delhi
SHRI M. R. CHATTERJEE ( <i>Alternate</i> )	Central Road Research Institute ( CSIR ), New Delhi
SHRI K. L. SETHI ( <i>Alternate</i> )	Central Building Research Institute ( CSIR ), Roorkee
DR MOHAN RAI	
DR S. S. REHSI ( <i>Alternate</i> )	Dalmia Cement ( Bharat ) Ltd, New Delhi
SHRI A. V. RAMANA	
DR K. C. NARANG ( <i>Alternate</i> )	Directorate General of Supplies and Disposals, New Delhi
SHRI G. RAMDAS	Structural Engineering Research Centre ( CSIR ), Madras
DR M. RAMAIAH	
DR A. G. MADHAVA RAO ( <i>Alternate</i> )	National Buildings Organization, New Delhi
DR A. V. R. RAO	
SHRI J. SEN GUPTA ( <i>Alternate</i> )	Geological Survey of India, Calcutta
SHRI R. V. CHALAPATHI RAO	
SHRI S. ROY ( <i>Alternate</i> )	Cement Corporation of India Ltd, New Delhi
SHRI ARJUN RIISINGHANI	
SHRI C. S. SHARMA ( <i>Alternate</i> )	Gammon India Ltd, Bombay
SHRI T. N. S. RAO	
SHRI S. A. REDDI ( <i>Alternate</i> )	Engineer-in-Chief's Branch, Army Headquarters
SHRI H. S. SATYANARYANA	
SHRI V. R. KOTNIS ( <i>Alternate</i> )	Central Board of Irrigation and Power, New Delhi
SECRETARY	
SHRI K. R. SAXENA ( <i>Alternate</i> )	The India Cement Ltd, Madras
SHRI K. A. SUBRAMANIAM	
SHRI P. S. RAMACHANDRAN ( <i>Alternate</i> )	Public Works Department, Government of Tamil Nadu, Madras
SUPERINTENDING ENGINEER ( DESIGNS )	
EXECUTIVE ENGINEER ( SM & R DIVISION ) ( <i>Alternate</i> )	Orissa Cement Ltd, New Delhi
SHRI L. SWAROOP	
SHRI D. S. BHANDARI ( <i>Alternate</i> )	Director General, ISI ( <i>Ex-officio Member</i> )
SHRI G. RAMAN, Director ( Civ Engg )	
	<i>Secretary</i>
	SHRI N. C. BANDOPADHYAYA
	Deputy Director ( Civ Engg ), ISI

( Continued on page 8 )

# *Indian Standard*

## SPECIFICATION FOR PLANETARY MIXER USED IN TESTS OF CEMENT AND POZZOLANA

### 0. FOREWORD

**0.1** This Indian Standard was adopted by the Indian Standards Institution on 12 March 1984, after the draft finalized by the Cement and Concrete Sectional Committee had been approved by the Civil Engineering Division Council.

**0.2** The Indian Standards Institution has already published a series of standards on different types of cement and methods of tests of cement. It has been recognized that reproducible and repeatable test results can be obtained only with standard testing equipment capable of giving the desired level of accuracy. The Sectional Committee, therefore, decided to bring out a series of specifications covering the requirements of equipment used for testing cement and concrete, to encourage their development and manufacture in the country.

**0.2.1** Accordingly, this standard has been prepared to cover requirements of planetary mixer used for determination of compressive and transverse strength of plastic mortar, determination of compressive strength of masonry cement and determination of lime reactivity of pozzolanic material with hydraulic lime. Use of this mixer is covered in IS : 4031-1968\* and IS : 1727-1967‡.

**0.3** For the purpose of deciding whether a particular requirement of this standard is complied with, the final value, observed or calculated, expressing the result of a test or analysis, shall be rounded off in accordance with IS : 2-1960‡. The number of significant places retained in the rounded off value should be the same as that of the specified value in this standard.

---

### 1. SCOPE

**1.1** This standard covers the requirements of planetary mixer used in the following tests:

- a) Determination of compressive and transverse strength of plastic mortar,

---

\*Methods of physical tests for hydraulic cement.

‡Methods of test for pozzolanic materials ( *first revision* ).

‡Rules for rounding off numerical values ( *revised* ).

- b) Determination of compressive strength of masonry cement, and
- c) Determination of lime reactivity of pozzolanic material with hydraulic lime.

## 2. MATERIALS

2.1 Materials of construction of different components of the mixer shall be as given in Table 1.

TABLE 1 MATERIALS OF CONSTRUCTION OF DIFFERENT COMPONENTS OF MIXER

SL No.	PART	MATERIAL	REF TO INDIAN STANDARD
(1)	(2)	(3)	(4)
i)	Mixing bowl	Stainless steel or other suitable material	IS : 5522-1978*
ii)	Paddle	Stainless steel or other suitable material	IS : 5522-1978*
iii)	Scraper	Rubber	—

\*Specification for stainless steel sheets and coils ( *first revision* ).

## 3. CONSTRUCTION

**3.1 Mixer** — It shall be an electrically driven mechanical mixer of the epicyclic type, which imparts both a planetary and a revolving motion to the mixer paddle. The relative motions of axial and planetary revolutions of the blade should be opposite to each other. The mixer shall have at least two speeds, controlled by positive mechanical means. ( Rheostat adjustment of speed shall not be acceptable). The first or slow speed shall revolve the paddle at a rate of  $140 \pm 5$  rev/min, with a planetary motion of approximately 62 rev/min. The second speed shall revolve the paddle at a rate of  $285 \pm 10$  rev/min with a planetary motion of approximately  $125 \pm 10$  rev/min. The mixer shall be capable of adjustment so that when the bowl is in the mixing position the clearance between the lower end of the paddle and the bottom of the bowl shall be approximately 2.5 mm but not less than the approximate diameter of a grain of the standard sand.

**3.2 Paddle** — The paddle shall be readily removable, made of stainless steel or any other equivalent material not attacked by cement, masonry cement, cement-pozzolana mixture or lime-pozzolana mixture and of hardness to prevent being abraded by silica sand, and shall conform to the basic design shown in Fig. 1A. The dimensions of the paddle shall be such that when it is in the mixing position the paddle outline conforms to the contour of

the bowl used with the mixer, and the clearance between corresponding points on the edge of the paddle and the side of the bowl in the position of closest approach shall be approximately 4 mm but not less than 0.85 mm.

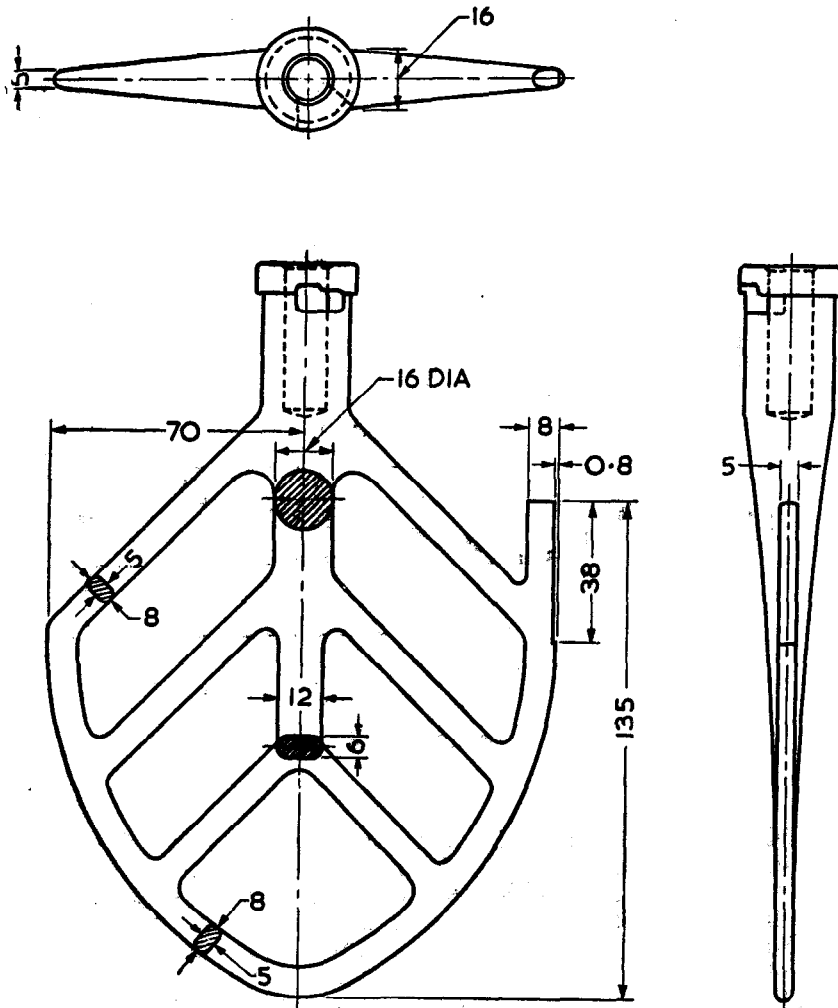

All dimensions in millimetres.  
1A Mixing Paddle

FIG. 1 PADDLE AND MIXING BOWL — Contd

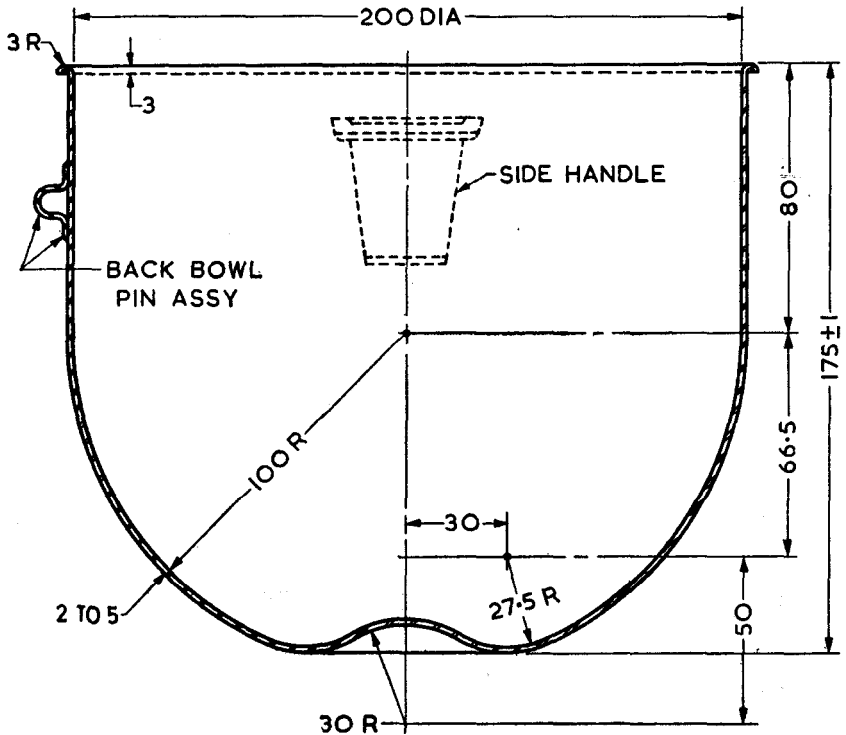

All dimensions in millimetres.  
1B A Mixing Bowl

FIG. 1 PADDLE AND MIXING BOWL

**3.3 Mixing Bowl** — The mixing bowl shall be removable and shall have a nominal capacity of 4.75 litres. It shall be of the general shape shown in Fig. 1B. It shall comply with the limiting dimensions shown in Fig. 1A and shall be made of stainless steel or any other equivalent material not attacked by cement, masonry cement, cement-pozzolana mixture or lime-pozzolana mixture and of hardness to prevent being abraded by silica sand. The bowl shall be so equipped that it will be positively held in the mixing apparatus in a fixed position during the mixing procedure. It shall be provided with a lid made of non-absorbing material and not attacked by cement, masonry cement, cement-pozzolana mixture or lime-pozzolana mixture.

**3.4 Scraper** — The scraper shall consist of a semi-rigid rubber blade attached to a handle about 150 mm long. The blade shall be about 75 mm long and 50 mm wide, and tapered to a thin edge about 1.5 mm thick.

#### **4. MARKING**

**4.1** The following information shall be clearly and indelibly marked on each component of the mixer as far as practicable in a way that it does not interfere with the performance of the mixer:

- a) Name of the manufacturer or his registered trade-mark or both, and
- b) Date of manufacture.

**4.1.1** The mixer may also be marked with the ISI Certification Mark.

**NOTE** — The use of the ISI Certification Mark is governed by the provisions of the Indian Standards Institution ( Certification Marks ) Act and the Rules and Regulations, made thereunder. The ISI Mark on products covered by an Indian Standard conveys the assurance that they have been produced to comply with the requirements of that standard under a well-defined system of inspection, testing and quality control which is devised and supervised by ISI and operated by the producer. ISI marked products are also continuously checked by ISI for conformity to that standard as a further safeguard. Details of conditions, under which a licence for the use of the ISI Certification Mark may be granted to manufacturers or processors, may be obtained from the Indian Standards Institution.



**IS : 10890 - 1984**

( *Continued from page 2* ).

**Instruments for Cement and Concrete Testing Subcommittee, BDC 2:10.**

*Convener*

**DR IQBAL ALI**

14-1-359, New Aghapura, Hyderabad 500001

*Members*

**SHRI P. D. AGARWAL**

**DR T. N. CHOJER ( Alternate )**

**PROF B. M. AHUJA**

**SHRI S. K. BANERJEE**

**DR R. K. DATTA**

**SHRI J. P. KAUSHUSH ( Alternate )**

**DIRECTOR**

**JOINT DIRECTOR ( Alternate )**

**EXECUTIVE ENGINEER (D) V**

**SHRI T. P. EKAMBARAM**

**SHRI H. K. GUHA**

**DEPUTY SECRETARY ( Alternate )**

**SHRI JATINDER SINGH**

**SHRI GURCHARAN SINGH ( Alternate )**

**SHRI P. J. JAGUS**

**SHRI D. A. WADIA ( Alternate )**

**SHRI M. R. JOSHI**

**SHRI Y. P. PATHAK ( Alternate )**

**PROF C. K. RAMESH**

**DR R. S. AYYAR ( Alternate )**

**DR V. V. SUBHA RAO**

**SHRI N. K. JAIN ( Alternate )**

**SHRI K. H. BABU ( Alternate )**

**SHRI A. V. S. R. SASTRI**

**SHRI PALVINDER SINGH ( Alternate )**

**SHRI K. L. SETHI**

**SHRI M. L. BHATIA ( Alternate )**

*Representing*

**Central Public Works Department, Government of Uttar Pradesh, Lucknow**

**Indian Institute of Technology, New Delhi**

**National Test House, Calcutta**

**Central Building Research Institute ( CSIR ), Roorkee**

**A.P. Engineering Research Laboratories, Hyderabad**

**Central Public Works Department, New Delhi**

**Highway Research Station, Madras**

**All India Instrument Manufacturers & Dealers Association, Bombay**

**Hydraulic Engineering Instruments, New Delhi**

**( Alternate )**

**Associated Cement Companies Ltd, Bombay**

**Research & Development Organization, Ministry of Defence**

**Indian Institute of Technology, Bombay**

**Cement Research Institute of India, New Delhi**

**Associated Instrument Manufacturers ( India ) Pvt Ltd, New Delhi; and Advisory Committee for Standardization of Instruments ( ACSI ), New Delhi**

**Central Road Research Institute ( CSIR ), New Delhi**