

IS : 10261 - 1982  
(Reaffirmed 1996)

*Indian Standard*  
REQUIREMENTS FOR  
SETTLING TANK ( CLARIFIER EQUIPMENT )  
FOR WASTE WATER TREATMENT

( First Reprint OCTOBER 1997 )

UDC 628.314.6

© *Copyright* 1983

**BUREAU OF INDIAN STANDARDS**  
MANAK BHAVAN, 9 BAHADUR SHAH ZAFAR MARG  
NEW DELHI 110002

# Indian Standard

## REQUIREMENTS FOR SETTLING TANK ( CLARIFIER EQUIPMENT ) FOR WASTE WATER TREATMENT

Public Health Engineering Equipment Sectional Committee, BDC 40

### Chairman

DR B. B. SUNDARESAN

### Representing

National Environmental Engineering Research  
Institute ( CSIR ), Nagpur

### Members

- |   |   |
|---|---|
| ADVISER ( PHE )                                     | Ministry of Works & Housing, New Delhi                                    |
| DR S. R. SUKLA ( <i>Alternate</i> )                 |   |
| SHRI N. S. BHAIKAVAN                                | Public Health Engineering Department, Government<br>of Kerala, Trivandrum |
| SHRI O. P. BISHNOI                                  | U. P. Jal Nigam, Lucknow  |
| SHRI S. S. SRIVASTAVA ( <i>Alternate</i> )          |   |
| SHRI R. C. P. CHAUDHARY                             | Engineers India Limited, New Delhi  |
| SHRI K. RUDRAPPA ( <i>Alternate</i> )               |   |
| SHRI D. K. CHOUDHURY                                | Geo-Miller & Co, Calcutta   |
| SHRI D. R. MALL ( <i>Alternate</i> )                |   |
| CHIEF ENGINEER                                      | Department of Health, Government of West Bengal,<br>Calcutta              |
| SHRI T. N. CHATTERJEE ( <i>Alternate</i> )          |   |
| CHIEF ENGINEER ( WATER )                            | Municipal Corporation of Delhi  |
| SHRI JAI NARAIN ( <i>Alternate</i> )                |   |
| SHRI S. K. DASGUPTA                                 | Calcutta Metropolitan Development Authority,<br>Calcutta                  |
| SHRI S. J. DUTTA ( <i>Alternate</i> )               |   |
| DEPUTY MUNICIPAL COMMISSIONER                       | Municipal Corporation of Greater Bombay, Bombay                           |
| HYDRAULIC ENGINEER ( <i>Alternate</i> I )           |   |
| CHIEF ENGINEER ( SEWERAGE ) ( <i>Alternate</i> II ) |   |
| SHRI B. R. N. GUPTA                                 | Engineer-in-Chief's Branch, Army Headquarters,<br>New Delhi               |
| SHRI K. V. KRISHNAMURTHY ( <i>Alternate</i> )       |   |
| SHRI R. KRISHNASWAMY                                | Tamil Nadu Water Supply & Drainage Board,<br>Madras                       |
| SHRI S. A. JAGDESAN ( <i>Alternate</i> )            |   |
| SHRI M. Y. MADAN                                    | The Hindustan Construction Co Ltd, Bombay                                 |
| SHRI C. E. S. RAO ( <i>Alternate</i> )              |   |

( Continued on page 2 )

© Copyright 1983

BUREAU OF INDIAN STANDARDS

This publication is protected under the *Indian Copyright Act* ( XIV of 1957 ) and reproduction in whole or in part by any means except with written permission of the publisher shall be deemed to be an infringement of copyright under the said Act.

( Continued from page 1 )

| <i>Members</i>                            | <i>Representing</i>   |
|---|---|
| SHRI S. R. MAJUMDER<br>MEMBER SECRETARY   | Paterson Engineering Co ( India ) Ltd, Calcutta<br>Central Board for Prevention and Control of Water<br>Pollution ( Ministry of Works & Housing ) |
| DR K. R. RANGANATHAN ( <i>Alternate</i> ) |   |
| SHRI L. S. MEHTA                          | Indian Chemical Manufacturers Association,<br>Bombay  |
| SHRI R. K. SHUKLA ( <i>Alternate</i> )    |   |
| SHRI A. R. MIR                            | Public Health Engineering Department, Government<br>of Jammu & Kashmir, Srinagar  |
| SHRI G. M. KANTH ( <i>Alternate</i> )     |   |
| SHRI D. V. S. MURTHY                      | M. P. State Prevention and Control of Water Pollution<br>Board, Bhopal  |
| SHRI V. S. BANSAL ( <i>Alternate</i> )    |   |
| SHRI S. S. NAIK                           | Hydraulic & General Engineers Pvt Ltd, Bombay   |
| SHRI D. R. KENKRE ( <i>Alternate</i> )    |   |
| SHRI R. NATARAJAN                         | Hindustan Dorr Oliver Ltd, Bombay   |
| SHRI B. M. RAHUL ( <i>Alternate</i> )     |   |
| SHRI S. K. NEOGI                          | Institution of Public Health Engineers India,<br>Calcutta   |
| SHRI D. K. GHOSH ( <i>Alternate</i> )     |   |
| SHRI M. M. PATEL                          | Indian Water Works Association, Bombay  |
| SHRI V. RAMAN                             | National Environmental Engineering Research<br>Institute ( CSIR ), Nagpur   |
| SHRI Y. K. RANGABAJU                      | The Fertilizer Corporation of India Ltd, New Delhi  |
| SHRI A. NARAYANAN ( <i>Alternate</i> )    |   |
| SHRI D. R. JAGANNATH RAO                  | Public Health Engineering Department, Govern-<br>ment of Madhya Pradesh, Bhopal   |
| SHRI M. G. VAIDYA ( <i>Alternate</i> )    |   |
| PROF S. SUBHA RAO                         | All India Institute of Hygiene & Public Health,<br>Calcutta   |
| SHRI A. V. RAO ( <i>Alternate</i> )       |   |
| REPRESENTATIVE                            | Public Health Engineering Department, Government<br>of Punjab, Chandigarh   |
| REPRESENTATIVE                            | Directorate General of Technical Development, New<br>Delhi  |
| REPRESENTATIVE                            | Public Health Engineering Department, Govern-<br>ment of Haryana, Chandigarh  |
| SHRI K. K. GANDHI ( <i>Alternate</i> )    |   |
| SHRI P. V. SOMASEKHAR                     | Public Works and Electric Department, Government<br>of Karnataka, Bangalore   |
| SHRI S. A. SWAMY                          | The Institution of Engineers ( India ), Calcutta  |
| SHRI P. S. TENDOLKAR                      | Candy Filters ( India ) Ltd, Bombay   |
| SHRI C. L. SASTRI ( <i>Alternate</i> )    |   |
| SHRI V. VARADARAJAN                       | Madras Metropolitan Water Supply and Sewerage<br>Board, Madras  |
| SHRI S. DAIVAMANI ( <i>Alternate</i> )    |   |
| SHRI G. RAMAN,<br>Director ( Civ Engg )   | Director General, BIS ( <i>Ex-officio Member</i> )  |

*Secretary*

SHRI A. K. AVASTHY  
Assistant Director ( Civ Engg ), BIS

( Continued on page 14 )

# *Indian Standard*

## REQUIREMENTS FOR SETTLING TANK ( CLARIFIER EQUIPMENT ) FOR WASTE WATER TREATMENT

### 0. FOREWORD

**0.1** This Indian Standard was adopted by the Indian Standards Institution on 24 September 1982, after the draft finalized by the Public Health Engineering Equipment Sectional Committee had been approved by the Civil Engineering Division Council.

**0.2** A series of Indian Standards covering various types of equipment used in waste water treatment are being formulated to give guidance to local bodies, public health engineering departments and others in setting up treatment plants. This standard covers the requirements for clarifiers which are normally provided for the removal of suspended solids from waste water. The location of clarifier tanks with respect to other units in the treatment plants shall be determined by the type of process adopted and flow sheet employed for treatment.

**0.3** The settling characteristics vary from waste to waste, and in some industry one waste stream to another or combined waste.

**0.3.1** The waste after neutralization when applied to clarifiers, can have higher over flow rate than that for the sewage ( as the chemical sludges usually have higher settling rate ). Therefore, the over flow rates for different industrial waste can be arrived at after having conducted laboratory settling columns studies, and the values may be modified taking into account the actual prototype. Recommendations given below for overflow rates, minimum side water depth, detention time, weir loadings, bottom slopes, etc, are only for general guidance and indicate the basis of preparation of this specification:

| <i>a) Overflow rates</i>                                  | <i>Average<br/>( m<sup>3</sup>/d, m )</i> |
|---|---|
| i) Primary settling tank                                  | 25-30                                     |
| ii) Primary settling tank followed by secondary treatment | 35-50                                     |
| iii) Primary settling tank with activated sludge return   | 25-35                                     |

- |  |       |
|--|-------|
| iv) Secondary settling tank for trickling filter                                   | 10-25 |
| v) Secondary settling tank for activated sludge<br>( excluding extended aeration ) | 15-35 |
| vi) Secondary settling tank for extended aeration                                  | 8-15  |
- b) *Minimum side water depth* — The minimum side water depth in rectangular or circular horizontal flow tanks shall not be less than 2.0 m. For clarification after activated sludge process, the minimum depth shall be 2.60 m.
- c) *Detention time* — For sewage treatment, the detention period in primary sedimentation tanks 2 to 2½ hours and in secondary sedimentation tank 1½ to 2 hours will produce the optimum results. Longer detention may be necessary in case of industrial wastes with or without chemical precipitation.
- d) *Weir loadings* — For primary, intermediate and secondary sedimentation tanks except in case of secondary tanks for activated sludge process, weir loading not greater than 100 m<sup>3</sup>/d/m for average flow is recommended. For secondary settling tank in activated sludge or its modifications, the weir loading shall not exceed 150 m<sup>3</sup>/d/m.
- e) *Bottom slopes* — The floors of settling tank shall be provided with sludge collection hoppers and the sludge scrapping mechanism shall be arranged to collect the settled solids from the entire floor area and deliver it to the collection hopper. The floor shall be sloped towards the centre in the case of hopper bottom tanks and to a central sludge pocket. The floor slope shall be of the order of 1 in 12 or steeper for circular and square tanks and one percent or less for rectangular tanks. Flat bottom tanks with continuous sludge removal may be used for secondary settling tank only.

For vertical flow tanks, the slope of the hopper should not be less than 60° to the horizontal.

All sharp corners of the clarifiers should be rounded.

**0.4** Typical sketch showing the details of settling tank is given in Fig. 1.

**0.5** In the formulation of this standard due weightage has been given to international coordination among the standards and practices prevailing in different countries in addition to relating it to the practices in the field in this country.

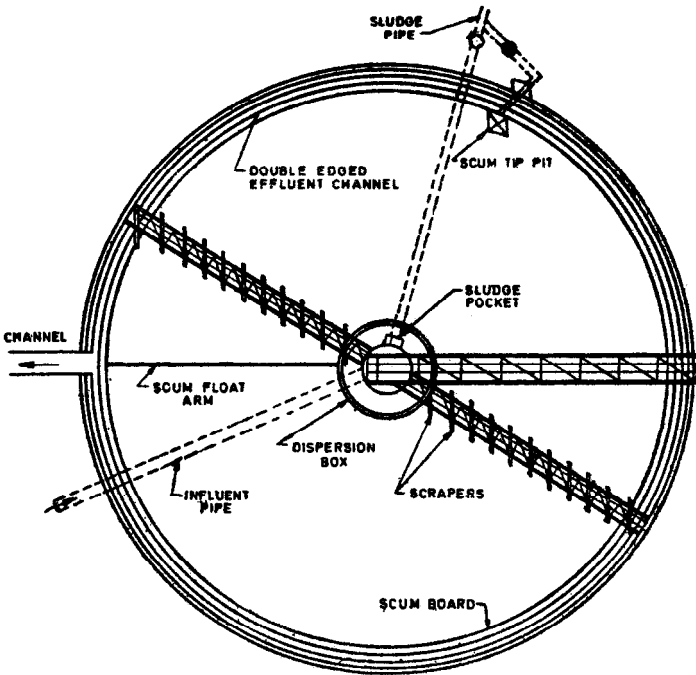

PLAN

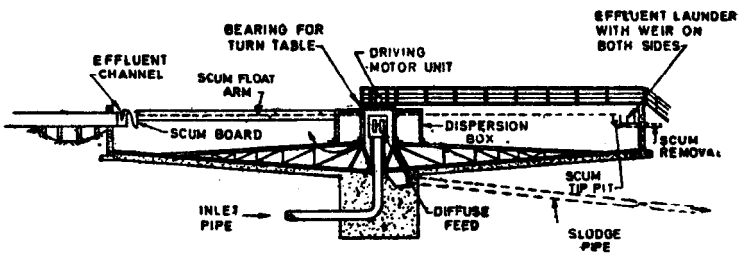

SECTIONAL ELEVATION

FIG. 1 TYPICAL SKETCH OF SETTLING TANK

**0.6** For the purpose of deciding whether a particular requirement of this standard is complied with, the final value, observed or calculated, expressing the result of a test or analysis, shall be rounded off in accordance with IS : 2-1960\*. The number of significant places retained in the rounded off value should be the same as that of the specified value in this standard.

---

## **1. SCOPE**

**1.1** This standard covers the requirements of settling tank used in treatment of waste water.

## **2. MATERIAL OF CONSTRUCTION**

**2.1** Materials to be used in different components are given in Table 1.

## **3. DESCRIPTION OF CONSTRUCTION**

### **3.1 Influent Pipe**

**3.1.1** The influent pipe laid underneath the floor of clarifier ( circular or square ) shall be embedded in concrete or in compacted sand in a excavated trench to ensure adequate protection to the pipe against settlement of concrete structure or subsoil water pressure. Pipe/pressure conduit and pipe joint after laying and before being embedded in concrete or before the floor or clarifier is laid shall be hydraulically tested to 2 times the maximum working static head and for internal and external pressures.

**3.1.2** The inlet pipe laid inside the tank, up to the dispersion box ( acting as deflector ) shall be adequately supported from the fixed bridge walkway. The dispersion box shall be made of mild steel plate not less than 6 mm thick, adequately stiffened.

**3.1.3** Inlet pipe for hopper bottom tank shall be laid across up to the centre and brought down vertically into the hopper portion. A typical illustration of hopper bottom tank is shown in Fig. 2.

**3.1.4** In the case of long horizontal settling tank, inlet pipe is fitted to a distribution channel inside at one end. This inlet channel shall be provided with adequate number of orifice holes at its bottom to provide uniform distribution of flow across the width of the tank.

---

\*Rules for rounding off numerical values ( *revised* ).

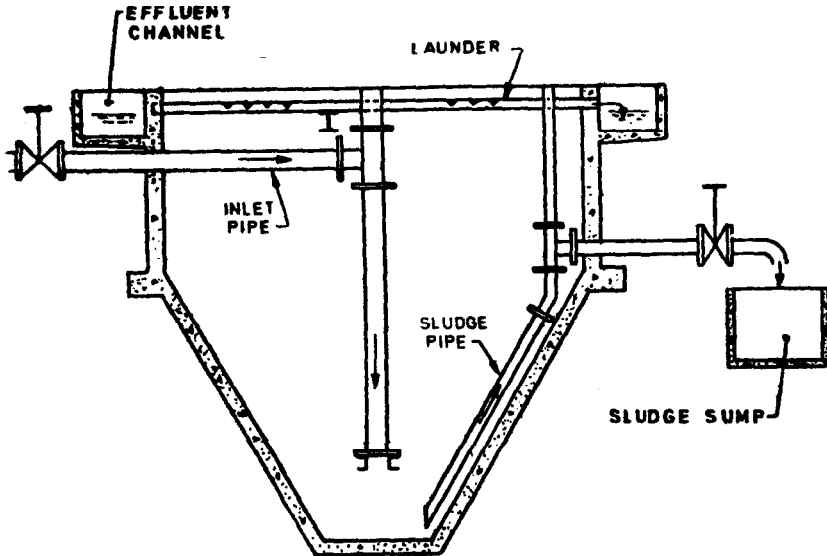

FIG. 2 TYPICAL SKETCH OF HOPPER BOTTOM SETTLING TANK

### 3.2 Sludge Draw Off Pipe

**3.2.1** Pipes after laying and jointing shall be tested to 2 times the maximum working hydrostatic head. The pipe laying shall be done as described in 3.1.1 for circular or square settling tank.

**3.2.2** For hopper bottom, sludge pipe shall follow the inclined surface of the hopper and come out of the tank through the vertical wall of the settling tank as shown in Fig. 2. The diameter of the sludge pipe shall not be less than 200 mm.

**3.2.3** For long rectangular settling tank, ridge and furrow arrangement along the length of the tank shall be provided for the collection of sludge ( see Fig. 3 ).

#### 3.2.4 Sludge Draw Off Valve

**3.2.4.1** The sludge draw off valves may be of cast iron sluice valves, or cast iron rubber-lined diaphragm valves. Where the valve is well below ground level, mild steel extension spindle fitted with hand wheel shall be provided for convenience of operation.



**TABLE 1 MATERIAL FOR CONSTRUCTION FOR DIFFERENT COMPONENTS OF SETTLING TANK ( CLARIFIER EQUIPMENT ) FOR WASTE WATER TREATMENT**

( Clause 2.1 )

| SL No. | COMPONENTS   | MATERIAL  | REFERENCE TO INDIAN STANDARDS                     |
|--------|--|---|---|
| (1)    | (2)  | (3)   | (4)   |
| 1.     | a) Influent pipe<br>( Pipe laid across the tank inside ) | Cast iron pipe<br>Steel pipe ( lined )<br>RCC conduit   | Class LA of IS : 1536-1976*<br>or IS : 1537-1976† |
|        | b) Pipe fittings   | Cast iron   | IS : 1538-1976‡                                   |
| 2.     | <i>Sludge draw off pipe</i>                              |   |   |
|        | a) Pipe  | Cast iron   | IS : 1536-1976* or<br>IS : 1537-1976‡             |
|        | b) Sluice valve  | Cast iron   | IS : 780-1980§                                    |
| 3.     | <i>Sludge scraping</i>                                   |   |   |
|        | a) Scraper blades  | Mild steel  | IS : 226-1975                                     |
|        | b) Frame/rake arm  | Mild steel  | IS : 226-1975                                     |
|        | c) <i>Rotating/ fixed bridge</i>                         |   |   |
|        | i) Bridge  | Mild steel<br>RCC   | IS : 226-1975  <br>—                              |
|        | ii) Traction rail  | Mild steel  | IS : 226-1975                                     |
|        | iii) Walkway   | Anti corrosive paint<br>or epoxy painted<br>or galvanized<br>mild steel grill or<br>galvanized chequered<br>plate | IS : 226-1975                                     |
|        | iv) Handrailing  | Anti corrosive paint<br>or epoxy painted<br>or galvanized<br>mild steel angle or<br>galvanized tube               | IS : 226-1975                                     |
|        | d) <i>Driving equipment</i>                              |   |   |
|        | i) Main driving wheel                                    | Cast iron<br>Cast steel   | IS : 210-1978¶<br>IS : 1030-1974**                |
|        | ii) Worm gear  | Cast iron<br>Cast aluminium<br>bronze   | IS : 210-1978¶<br>IS : 617-1975††                 |
|        | iii) Bevel gear  | Cast iron   | IS : 210-1978¶                                    |
|        | iv) Spur gear  | Alloy steel   | IS : 1570-1961‡‡                                  |
|        | v) Gear box cover  | Cast iron   | IS : 210-1978¶                                    |

( Continued )

**TABLE 1 MATERIAL FOR CONSTRUCTION FOR DIFFERENT COMPONENTS OF SETTLING TANK ( CLARIFIER EQUIPMENT ) FOR WASTE WATER TREATMENT— Contd**

| Sl. No. | COMPONENTS                     | MATERIAL   | REFERENCE TO INDIAN STANDARDS |
|---------|--------------------------------|--|-------------------------------|
| (1)     | (2)                            | (3)  | (4)                           |
| vi)     | Cover for main driving wheel   | Mild steel ( epoxy coated and galvanized )               | IS : 226-1975                 |
|         |                                | Cast iron  | IS : 210-1978¶                |
| vii)    | Housing for main driving wheel | Cast iron  | IS : 210-1978¶                |
| viii)   | Worm gear housing              | Cast iron  | IS : 210-1978¶                |
| ix)     | Bearing balls                  | High carbon steel  | IS : 2898-1976§§              |
| x)      | Coupling                       | Cast iron  | IS : 2693-1964                |
| xi)     | Chain sprocket drive           | Steel  | IS : 2403-1975¶¶              |
| xii)    | Traction wheel                 | Rubber/chrome-nickel tyred or carbon steel case hardened | —                             |
| xiii)   | Shaft                          | Cold finished steel                                      | IS : 1570-1961††              |
| xiv)    | Cage                           | Mild steel   | IS : 226-1975                 |
| xv)     | Weirs                          | Mild steel   | IS : 226-1975                 |
|         |                                | Fibre reinforced Plastic                                 | —                             |
| xvi)    | Dispersion box                 | Mild steel   | IS : 226-1975                 |

\*Specification for centrifugally cast ( spun ) iron pressure pipes for water, gas and sewage ( *second revision* ).

†Specification for vertically cast iron pressure pipes for water, gas and sewage ( *first revision* ).

‡Specification for cast iron fittings for pressure pipes for water, gas and sewage ( *second revision* ).

§Specification for sluice valves for water-works purposes ( 50 to 300 mm size ) ( *fourth revision* ).

||Specification for structural steel ( standard quality ) ( *fifth revision* ).

¶Specification for grey iron castings ( *third revision* ).

¶¶Specification for carbon steel castings for general engineering purposes ( *second revision* ).

††Specification for aluminium and aluminium alloy ingots and castings for general engineering purposes ( *second revision* ).

‡‡Schedules for wrought steels for general engineering purposes.

§§Specification for steel balls for rolling bearings ( *first revision* ).

|||Specification for cast iron flexible couplings.

¶¶¶Specification for transmission steel roller chains and chain wheels ( *first revision* ).

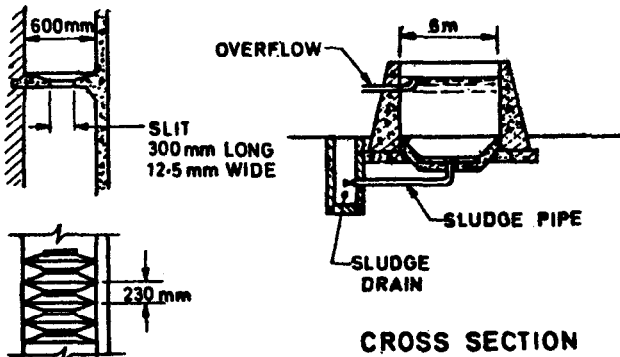
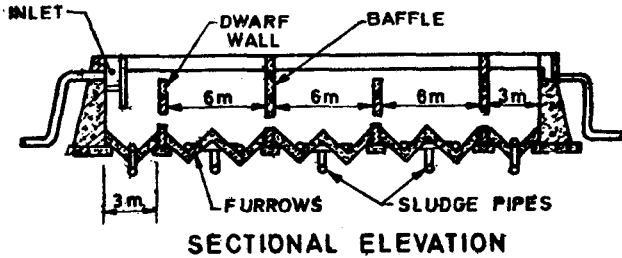
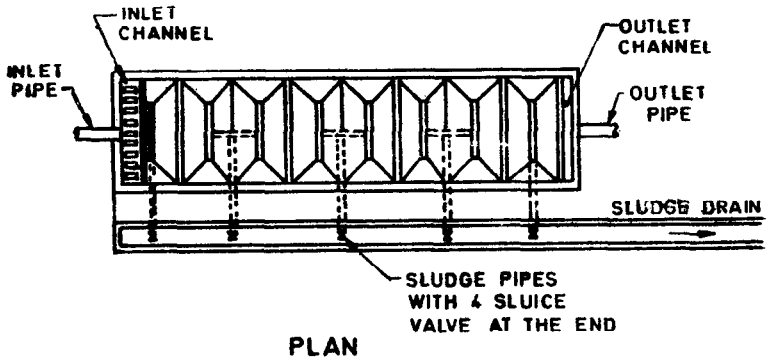

DETAILS OF SLITS  
INLET CHANNEL

FIG. 2 TYPICAL DETAILS OF RECTANGULAR SETTLING TANK

**3.4.4.2** In case timer controlled sludge valve is used, a by-pass with a sluice valve shall be provided for the same. In addition, two sluice valves, one on either side of the timer controlled valve shall be used to enable the latter to be completely removed for repairs if so required at any time. This timer controlled sludge valve shall be rising spindle type sluice valve with cylinder. Either water or pneumatic pressure shall only be used for the operation of above valves. Timer shall be electrically operated mechanical type or electronic. A solenoid operated pilot valve is required to operate the above valves.

#### **4. CLARIFIED/SETTLED WATER COLLECTION FROM TOP**

**4.1** For circular or square tank, normally peripheral collecting launder is provided. To ensure uniform collection all along the periphery orifices at predetermined points or mild steel weir plate with 90° 'V' notches along with suitable weir clamps shall be provided. Weir plate shall not be less than 6 mm thick ( see IS : 9108-1979\* ).

**4.1.1** Anchor bolts shall be of galvanized steel.

**4.2** For long rectangular settling tank over 20 m length, series of collecting launders with inter-connection across the width of the tank at the opposite end of inlet shall be provided to cater for the required weir loading. These launders may have weir plate or submerged orifice holes.

#### **5. SLUDGE SCRAPPING**

**5.1** For circular, square and rectangular tank without hopper bottom sludge scrapping mechanism shall be provided. Long rectangular tanks without sludge scrapping mechanism with a duplicate tank as stand-by for manual sludge cleaning may be used. For horizontal flow rectangular settling tanks scraper supported on travelling bridge moving to and fro along the length or scraper mounted on endless chain may be provided.

**5.2** Sludge scrapping is done by inclined steel plates known as scraper blades fitted to the structural steel rake arm of frame. Blades shall be inclined to the axis of the frame or rake, so as to push the sludge towards centre. Blades are normally straight or curved inward. Horizontal projection of scrapers blades shall overlap each other. The scrapping blades are provided normally for  $\frac{1}{4}$  or full diameter of the tank depending on its size and also considering peripheral speed of the scrapping arm. This scrapping arm is either attached to a rotating bridge by means of vertical supports or attached to a centre drive cage. Rotating bridge is driven by a motor, reduction gear box, etc, at the periphery and centre drive cage is driven by the same method at the centre of the tank. Further

---

\*Liquid flow measurement in open channels using thin plate weirs.

scraper arm extending full diameter of the tank can also be driven by a rotating bridge driven at the periphery, scraper arm being attached to centre cage which is in turn fixed to the rotating bridge at the centre of the tank. For large size tanks that is 55 m diameter or above, the bridge sometimes extends to the full diameter driven at both ends and scrapers are attached to the bridge by vertical supports.

For square tanks, a fixed bridge up to the centre of the tank is provided. Raking arms extending full diameter have pivoted pentagraph-action extensions with corner blades attached to the outer ends. Corrosion resistant wheels mounted on the extension arms ride against steel plates embedded in the side walls to guide corner scraper blades. The pivoted extension of arms kept in contact with the tank walls at all times by a spring.

### 5.3 Scraper Drive

**5.3.1 Centre Drive** — Centre drive mechanism shall consist of a drive unit with overload alarm, tipping device, structural steel scraper arms and bridge, handrail, walkway ( up to the centre ) and in case of primary clarifiers, the mechanism shall also have a skimmer with scum baffle and scum collection tank. It shall be arranged to provide the required speed. It shall consist of internal and external spur gear and pinion assembly driven by a motor through a series of reduction gear boxes which in turn will provide the required speed to the scraper arms. The chain drive may be incorporated if necessary. The reduction gear shall preferably be oil-immersed type, and the motor shall conform to the requirements of IS : 325-1970\* or IS : 996-1964† as applicable.

**5.3.2** This drive is mounted on an end carriage on which the rotating bridge is also mounted. The drive consists of a motor and reduction gear box driving the traction wheel through a spur or bevel gear or chain drive. The tip speed for circular tanks shall not exceed 3 m/min and for rectangular tanks, it shall not exceed 0.3 m/min.

**5.4** Protective devices for motors to stop against overload shall be provided.

**5.5 Scum Removal** — The skimmer shall consist of a structural steel unit spanning between the dispersion box and periphery of the tank and arranged in such a manner as to collect the scum at one point near the periphery of the tank. The skimmer arm shall be provided with neoprene rubber skimming device attached to the skimmer blade. A scum baffle, at least 15 cm above water level, and extending to at least 30 cm below

---

\*Specification for three-phase induction motors ( *third revision* ).

†Specification for single-phase small ac and universal electric motors ( *revised* ).

the water level, shall be provided along the entire periphery for preventing escape of scum with the clarified sewage. A scum trough of mild steel or RCC and of adequate size shall be provided for collection and disposal of scum.

**5.6 Bridge** — If bridge is less than 90 cm high, hand railing shall be provided on top beam so as to make a total height of 1.0 m.

## 6. TESTING OF SCRAPPING MECHANISM

**6.1** Bridge or centre drive shall be run in dry condition to check alignment of traction wheels, rails and mechanical fouling of scrapping arms and blades with floor or walls of the tank. Particular attention shall be given to the traction wheel so that it never slips on the rails. Dry running should be continued for at least 4 to 5 hours.

## 7. PAINTING

**7.1** All fabricated surfaces to be painted shall be thoroughly dried and freed from rust and grease. All steel components shall be given coat of red oxide primer and three coats of finish paint [ see IS : 1477 ( Part I )-1971\* and IS : 1477 ( Part II )-1971† ].

---

\*Code of practice for painting of ferrous metals in buildings : Part I Pretreatment ( *first revision* ).

†Code of practice for painting of ferrous metals in buildings : Part II Painting ( *first revision* ).

( Continued from page 2 )

Waste Water Treatment Equipment Subcommittee, BDC 40 : 2

| <i>Convener</i>  | <i>Representing</i>  |
|--|--|
| DR B. B. SUNDARESAN  | National Environmental Engineering Research Institute ( CSIR ), Nagpur           |
| <i>Members</i>   |  |
| SRI S. K. GADKARI ( <i>Alternate to</i><br>Dr B. B. Sundaresan ) |  |
| SRI R. R. BAGRI  | Institution of Public Health Engineers India,<br>Calcutta                        |
| SRI S. K. NEOGI ( <i>Alternate</i> )                             |  |
| SRI N. S. BHAIKAVAN  | Public Health Engineering Department, Govern-<br>ment of Kerala, Trivandrum      |
| SRI S. P. JAMES ( <i>Alternate</i> )                             |  |
| SRI S. BHOTALINGAM   | Kerala State Board for Prevention and Control of<br>Water Pollution, Trivandrum  |
| SRI J. D. JOYSINGH ( <i>Alternate</i> )                          |  |
| SRI O. P. BISHNOI  | Uttar Pradesh Jal Nigam, Lucknow   |
| SRI S. S. SRIVASTAVA ( <i>Alternate</i> )                        |  |
| CHAIRMAN   | Haryana State Board for Prevention and Control of<br>Water Pollution, Chandigarh |
| MEMBER-SECRETARY ( <i>Alternate</i> )                            |  |
| CHIEF ENGINEER ( SEWERAGE )                                      | Municipal Corporation of Greater Bombay  |
| DEPUTY CHIEF ENGINEER<br>( SEWERAGE ) ( <i>Alternate</i> )       |  |
| SRI M. M. DATTA  | Central Public Health and Environmental Engineer-<br>ing Organization, New Delhi |
| DR I. RADHAKRISHNAN ( <i>Alternate</i> )                         |  |
| SRI M. Y. MADAN  | The Hindustan Construction Co Ltd, Bombay  |
| SRI C. E. S. RAO ( <i>Alternate</i> )                            |  |
| PROF B. L. MAHABAL   | Victoria Jubilee Technical Institute, Bombay                                     |
| SRI R. V. S. MURTHY ( <i>Alternate</i> )                         |  |
| SRI U. C. MANKAD   | M/s Geo-Miller & Co Pvt Ltd, New Delhi   |
| SRI D. K. CHAUDHURY ( <i>Alternate</i> )                         |  |
| MEMBER-SECRETARY   | Central Board for the Prevention and Control of<br>Water Pollution, New Delhi    |
| DR K. R. RANGANATHAN ( <i>Alternate</i> )                        |  |
| SRI D. V. S. MURTHY  | M. P. State Prevention and Control of Water Pollu-<br>tion Board, Bhopal         |
| SRI S. S. NAIK   | Hydraulic & General Engineers Pvt Ltd, Bombay                                    |
| SRI D. R. KENKRE ( <i>Alternate</i> )                            |  |
| SRI R. NATARAJAN   | Hindustan Dorr-Oliver Ltd, Bombay  |
| SRI B. M. RAHUL ( <i>Alternate</i> )                             |  |
| DR N. RAJASEKHARAN   | Pennwait India Limited, Bombay   |
| PROF S. SUBHA RAO  | All India Institute of Hygiene & Public Health,<br>Calcutta                      |
| SRI A. V. RAO ( <i>Alternate</i> )                               |  |
| DR K. RUDRAPPA   | Engineers India Limited, New Delhi   |
| SRI R. N. TIWARI ( <i>Alternate</i> )                            |  |
| SRI V. SATYAMURTHI   | M/s EIMCO-KCP Ltd, Madras  |
| SRI T. SUBRAHMANYAM ( <i>Alternate</i> )                         |  |
| SRI C. L. SASTRI   | Candy Filters ( India ) Ltd, Bombay  |
| SRI D. B. PARMAR ( <i>Alternate</i> )                            |  |

# BUREAU OF INDIAN STANDARDS

## Headquarters:

Manak Bhavan, 9 Bahadur Shah Zafar Marg, NEW DELHI 110002

Telephones: 323 0131, 323 3375, 323 9402

Fax : 91 11 3234062, 91 11 3239399, 91 11 3239382

Telegrams : Manaksanstha

(Common to all Offices)

## Central Laboratory:

Plot No. 20/9, Site IV, Sahibabad Industrial Area, SAHIBABAD 201010

Telephone

8-77 00 32

## Regional Offices:

Central : Manak Bhavan, 9 Bahadur Shah Zafar Marg, NEW DELHI 110002 323 76 17

\*Eastern : 1/14 CIT Scheme VII M, V.I.P. Road, Maniktola, CALCUTTA 700054 337 86 62

Northern : SCO 335-336, Sector 34-A, CHANDIGARH 160022 60 38 43

Southern : C.I.T. Campus, IV Cross Road, CHENNAI 600113 235 23 15

†Western : Manakalaya, E9 Behind Marol Telephone Exchange, Andheri (East),  
MUMBAI 400093 832 92 95

## Branch Offices:

'Pushpak', Nurmohamed Shaikh Marg, Khanpur, AHMEDABAD 380001 550 13 48

‡Peenya Industrial Area, 1st Stage, Bangalore - Tumkur Road,  
BANGALORE 560058 839 49 55

Gangotri Complex, 5th Floor, Bhadbhada Road, T. T. Nagar, BHOPAL 462003 55 40 21

Plot No. 62-63, Unit VI, Ganga Nagar, BHUBANESHWAR 751001 40 36 27

Kalaikathir Buildings, 670 Avinashi Road, COIMBATORE 641037 21 01 41

Plot No. 43, Sector 16 A, Mathura Road, FARIDABAD 121001 8-28 88 01

Savitri Complex, 116 G. T. Road, GHAZIABAD 201001 8-71 19 96

53/5 Ward No. 29, R. G. Barua Road, 5th By-lane, GUWAHATI 781003 54 11 37

5-8-58C, L. N. Gupta Marg, Nampally Station Road, HYDERABAD 500001 20 10 83

E-52, Chitaranjan Marg, C-Scheme, JAIPUR 302001 37 29 25

117/418 B, Sarvodaya Nagar, KANPUR 208005 21 68 76

Seth Bhawan, 2nd Floor, Behind Leela Cinema, Naval Kishore Road,  
LUCKNOW 226001 23 89 23

Patliputra Industrial Estate, PATNA 800013 26 23 05

T. C. No. 14/1421, University P. O. Palayam,  
THIRUVANANTHAPURAM 695034 6 21 17

NIT Building, Second Floor, Gokulpat Market, NAGPUR 440010 52 51 71

Institution of Engineers ( India ) Building, 1332 Shivaji Nagar, PUNE 411005 32 36 35

\*Sales Office is at 5 Chowringhee Approach, P. O. Princep Street,  
CALCUTTA 700072 27 10 85

†Sales Office is at Novelty Chambers, Grant Road, MUMBAI 400007 309 65 28

‡Sales Office is at 'F' Block, Unity Building, Narashimaraja Square,  
BANGALORE 560002 222 39 71