

भारतीय मानक

बंधन सामग्री — चूड़ीदार बंधन सामग्री — इस्पात
संरचनाओं हेतु स्टेप काबले — विशिष्टि

(पहला पुनरीक्षण)

Indian Standard

FASTENERS — THREADED STEEL
FASTENERS — STEP BOLTS FOR STEEL
STRUCTURES — SPECIFICATION

(*First Revision*)

ICS 21.060.01

© BIS 2001

BUREAU OF INDIAN STANDARDS
MANAK BHAVAN, 9 BAHADUR SHAH ZAFAR MARG
NEW DELHI 110002

FOREWORD

This Indian Standard (First Revision) was adopted by the Bureau of Indian Standards, after the draft finalized by the Bolts, Nuts and Fasteners Accessories Sectional Committee and had been approved by the Basic and Production Engineering Division Council.

This standard was originally issued in 1982. Subsequent to the publication, three amendments have been issued. This revision has been taken up to incorporate these amendments as well as to make in line with the actual products which are being used by the electrical transmission and tower erection industries.

Step bolts are used to gain access to the top of steel structures including transmission towers. For safety reasons, while gaining access to the top of the structure, with the help of step bolts, the maximum total weight of a person including the bolts, nuts, tools and tackles that he may carry with him, should not exceed 150 kg.

Hexagon bolts intended for fabrication of general steel structures are covered in IS 6639 'Hexagon bolts for steel structures'.

For the purpose of deciding whether a particular requirement of this standard is complied with, the final value, observed or calculated, expressing the result of a test or analysis, shall be rounded off in accordance with IS 2 : 1960 'Rules for rounding off numerical values (*revised*)'. The number of significant places retained in the rounded off values should be the same as that of the specified value in this standard.

Indian Standard

FASTENERS — THREADED STEEL FASTENERS — STEP BOLTS FOR STEEL STRUCTURES — SPECIFICATION

(*First Revision*)

1 SCOPE

1.1 This standard covers the requirements for step bolt used in steel structures including transmission towers to gain access to the top.

1.2 Each bolt shall be supplied with two hexagon nuts.

2 REFERENCES

The following standards contain provisions which through reference in this text, constitute provision of this standard. At the time of publication, the editions indicated were valid. All standards are subject to revision and parties to agreements based on this standard are encouraged to investigate the possibility of applying the most recent editions of the standards indicated below:

<i>IS No.</i>	<i>Title</i>
1367	Technical supply conditions for threaded steel fasteners:
(Part 2) : 1979	Product grades and tolerances (<i>second revision</i>)
(Part 3) : 1991	Mechanical properties and test methods for bolts, screws and studs with full loadability (<i>third revision</i>)
(Part 9/Sec2) : 1993	Surface discontinuities: Section 2 Bolts, screws and studs for special applications (<i>third revision</i>)
ISO 6157-3 : 1988	
(Part 13) : 1983	Hot-dip galvanized coatings on threaded fasteners (<i>second revision</i>)
(Part 17) : 1996	Inspection, sampling and acceptance procedure (<i>third revision</i>)
(Part 18) : 1996	Packaging (<i>third revision</i>)
1369 : 1982	Dimensions of screw thread run-outs and undercuts (<i>second revision</i>)
2016 : 1967	Plain washers (<i>first revision</i>)
4218	ISO general purpose metric screw threads:
Part 1 : 2001	Basic profile (<i>second revision</i>)
ISO 68-1 : 1998	

IS No.

Title

Part 2 : 2001 ISO 261 : 1998	General plan (<i>second revision</i>)
Part 3 : 1999 ISO 724 : 1993	Basic dimensions (<i>second revision</i>)
Part 4 : 2001 ISO 262 : 1998	Selected sizes for screws, bolts and nuts (<i>second revision</i>)
4759 : 1996	Hot-dip zinc coating on structural steel and other allied products (<i>third revision</i>)
14394 : 1996	Industrial fasteners—Hexagon nuts of product grade C— Hot-dip galvanized—Specification (size range M 12 to M 36)

3 DIMENSIONS AND TOLERANCES

The dimensions and tolerances for step bolts shall be as given in Fig. 1.

4 GRADES

The step bolts shall be of product Grade C as specified in IS 1367 (Part 2).

5 MECHANICAL PROPERTIES

The step bolts shall conform to the requirements of property class 4.6 as specified in IS 1367 (Part 3).

6 MATING NUTS AND WASHERS

6.1 Nuts

The hexagon nuts used (*see 1.2*) with step bolts covered in this standard shall be of property class 5 and conforms to the requirements of IS 14394.

6.2 Washers

6.2.1 The plain washers used on these bolts shall be of Type A punched washers type and conform to the requirements given in IS 2016 except the thickness of washers which shall be 5 ± 1 mm.

6.2.2 The washers supplied along with bolts shall be hot-dip galvanized and in accordance with 8.2.

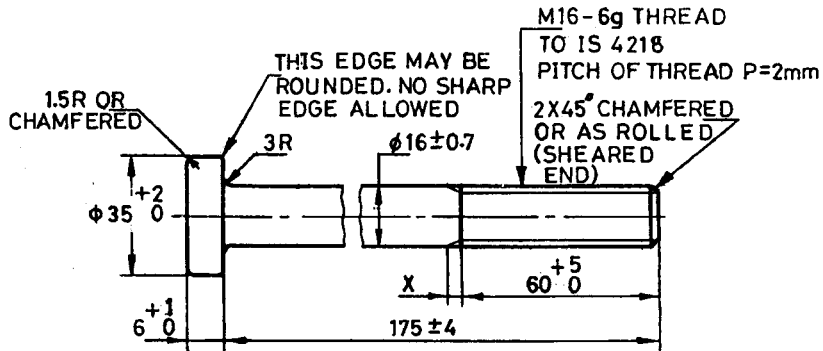

All dimensions in millimetres.
 'x' according to IS 1369

FIG. 1 DIMENSIONS FOR STEP BOLT

7 GENERAL REQUIREMENTS

The permissible surface discontinuities of the step bolts shall conform to IS 1367(Part 9/Sec 2).

8 FINISH

8.1 The step bolts shall be galvanized in accordance with IS 1367 (Part 13). All dimensions given in Fig. 1 shall apply before galvanizing.

8.2 The plain washers supplied alongwith the step bolts covered in this standard shall be hot-dip galvanized in accordance with the requirements of IS 4759.

8.3 Hot-dip galvanized bolts, nuts and washers shall be passivate by dipping, immediately after galvanizing in a 0.15 percent solution of sodium dichromate with

0.5 percent concentrated sulphuric acid maintained at a temperature more than 32°C to provide protection against wetstorage strain.

9 SAMPLING, INSPECTION AND ACCEPTANCE CRITERIA

The sampling, inspection and acceptance criteria shall be in accordance with IS 1367 (Part 17).

10 TESTS

10.1 The step bolts shall not have any permanent set when subjected to the cantilever test as shown in Fig. 2.

10.1.1 Before carrying out the cantilever test, the step bolt shall be loaded with 150 kg for 10 seconds with the set up shown in Fig. 2.

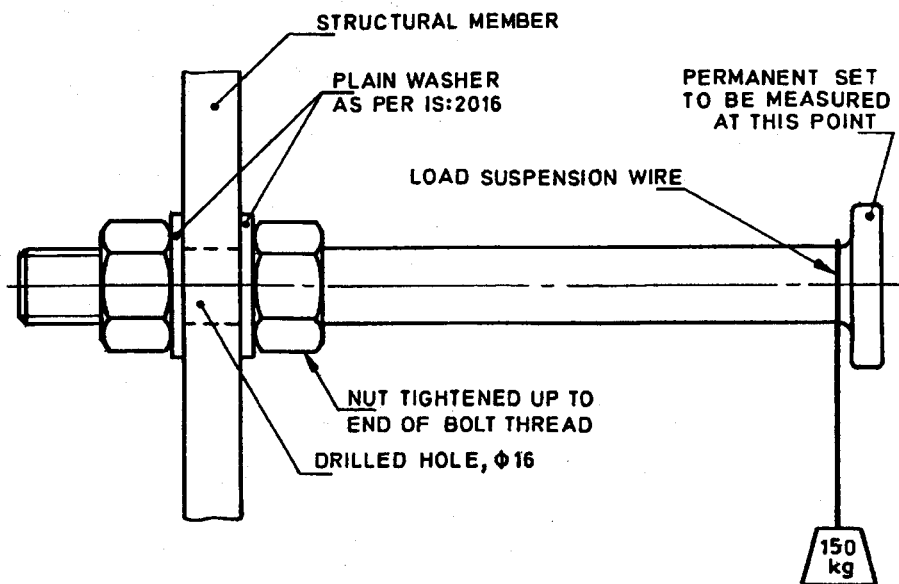

All dimensions in millimetres.

FIG. 2 CANTILEVER TEST

The bolts then shall be loaded again with 150 kg load for 10 seconds and there shall be no permanent set at the point indicated, after withdrawal of the load subject to a tolerance of 30 μ m for measurement error.

Both these loadings shall be done after the step bolts and nuts are tightly fixed as shown in Fig. 2.

11 DESIGNATION

The step bolts shall be designated by the size, length and the number of this Indian Standard. The letter NN shall be added to the designation to indicate supply with two nuts.

Example:

A step bolt of size M16 and length 175 mm with two hexagon nuts shall be designated as:

Step Bolt M16 \times 175 NN IS 10238

12 MARKING

12.1 The marking on the step bolts shall be in accordance with the IS 1367(Part 3).

12.2 BIS Certification Marking

The use of Standard Mark is governed by the provision of the *Bureau of Indian Standards Act, 1986* and Rules and Regulations made thereunder. The details of conditions under which the licence for the use of the Standard Mark may be granted to manufacturers or producers may be obtained from the Bureau of Indian Standards.

13 PACKAGING

The packaging of step bolts shall be in accordance with IS 1367 (Part 18).

Bureau of Indian Standards

BIS is a statutory institution established under the *Bureau of Indian Standards Act, 1986* to promote harmonious development of the activities of standardization, marking and quality certification of goods and attending to connected matters in the country.

Copyright

BIS has the copyright of all its publications. No part of these publications may be reproduced in any form without the prior permission in writing of BIS. This does not preclude the free use, in the course of implementing the standard, of necessary details, such as symbols and sizes, type or grade designations. Enquiries relating to copyright be addressed to the Director (Publications), BIS.

Review of Indian Standards

Amendments are issued to standards as the need arises on the basis of comments. Standards are also reviewed periodically; a standard along with amendments is reaffirmed when such review indicates that no changes are needed; if the review indicates that changes are needed, it is taken up for revision. Users of Indian Standards should ascertain that they are in possession of the latest amendments or edition by referring to the latest issue of 'BIS Catalogue' and 'Standards: Monthly Additions'.

This Indian Standard has been developed from Doc : No. **BP 33 (0092)**.

Amendments Issued Since Publication

Amend No.	Date of Issue	Text Affected

BUREAU OF INDIAN STANDARDS

Headquarters :

Manak Bhavan, 9 Bahadur Shah Zafar Marg, New Delhi 110 002
Telephones : 323 01 31, 323 33 75, 323 94 02

Telegrams : Manaksanstha
(Common to all offices)

Regional Offices :

	Telephone
Central : Manak Bhavan, 9 Bahadur Shah Zafar Marg NEW DELHI 110 002	{ 323 76 17 323 38 41
Eastern : 1/14 C. I. T. Scheme VII M, V. I. P. Road, Kankurgachi CALCUTTA 700 054	{ 337 84 99, 337 85 61 337 86 26, 337 91 20
Northern : SCO 335-336, Sector 34-A, CHANDIGARH 160 022	{ 60 38 43 60 20 25
Southern : C. I. T. Campus, IV Cross Road, CHENNAI 600 113	{ 235 02 16, 235 04 42 235 15 19, 235 23 15
Western : Manakalaya, E9 MIDC, Marol, Andheri (East) MUMBAI 400 093	{ 832 92 95, 832 78 58 832 78 91, 832 78 92
Branches : AHMADABAD. BANGALORE. BHOPAL. BHUBANESHWAR. COIMBATORE. FARIDABAD. GHAZIABAD. GUWAHATI. HYDERABAD. JAIPUR. KANPUR. LUCKNOW. NAGPUR. PATNA. PUNE. RAJKOT. THIRUVANANTHAPURAM.	