

IS : 10108 - 1982
(Reaffirmed 1995)

Indian Standard

**CODE OF PRACTICE FOR
SAMPLING OF SOILS BY THIN WALL SAMPLER
WITH STATIONARY PISTON**

(First Reprint SEPTEMBER 1998)

UDC 624.131.36 : 006.76

© Copyright 1982

**BUREAU OF INDIAN STANDARDS
MANAK BHAVAN, 9 BAHADUR SHAH ZAFAR MARG
NEW DELHI 110002**

Indian Standard

CODE OF PRACTICE FOR SAMPLING OF SOILS BY THIN WALL SAMPLER WITH STATIONARY PISTON

Soil Engineering and Rock Mechanics Sectional Committee, BDC 23

Chairman

DR JAGDISH NARAIN

Representing

University of Roorkee, Roorkee

Members

- | | |
|---|--|
| ADDITIONAL DIRECTOR, IRI | Irrigation Department, Government of Bihar, Patna |
| ADDITIONAL DIRECTOR RESEARCH (F.E.), RDSO | Ministry of Railways |
| DEPUTY DIRECTOR RESEARCH (SOIL MECH), RDSO (<i>Alternate</i>) | |
| SHRI P. D. AGARWAL | Public Works Department, Government of Uttar Pradesh, Lucknow |
| DR B. L. DHAWAN (<i>Alternate</i>) | |
| DR ALAM SINGH | University of Jodhpur, Jodhpur |
| COL AVTAR SINGH | Engineer-in-Chief's Branch, Army Headquarters (Ministry of Defence) |
| LT-COL V. K. KANITKAR (<i>Alternate</i>) | |
| CHIEF ENGINEER (D & R) | Irrigation Department, Government of Punjab, Chandigarh |
| DR G. S. DHILLON (<i>Alternate</i>) | |
| SHRI M. C. DANDAVATE | The Concrete Association of India, Bombay |
| SHRI N. C. DUGGAL (<i>Alternate</i>) | |
| SHRI A. G. DASTIDAR | In personal capacity (5 Hungerford Street, 12/1 Hungerford Court, Calcutta 700017) |
| DR G. S. DHILLON | Indian Geotechnical Society, New Delhi |
| DIRECTOR, IRI | Irrigation Department, Government of Uttar Pradesh, Roorkee |
| SHRI A. H. DIVANJI | Asia Foundations and Construction (P) Ltd, Bombay |
| SHRI A. N. JANGLE (<i>Alternate</i>) | |
| DR GOPAL RANJAN | Institution of Engineers (India), Calcutta |
| DR GOPAL RANJAN | University of Roorkee, Roorkee |
| SHRI S. GUPTA | Cemindia Co Ltd, Bombay |
| SHRI N. V. DE SOUSA (<i>Alternate</i>) | |
| SHRI G. S. JAIN | G. S. Jain & Associates, Roorkee |
| SHRI VIJAY K. JAIN (<i>Alternate</i>) | |

(Continued on page 2)

© Copyright 1982

BUREAU OF INDIAN STANDARDS

This publication is protected under the *Indian Copyright Act (XIV of 1957)* and reproduction in whole or in part by any means except with written permission of the publisher shall be deemed to be an infringement of copyright under the said Act.

(Continued from page 1)

<i>Members</i>	<i>Representing</i>
SHRI A. B. JOSHI DEPUTY DIRECTOR (CSMRS) (<i>Alternate</i>)	Central Water Commission, New Delhi
COL M. V. KAYERKAR SHRI V. B. GHORPADE (<i>Alternate</i>)	Ministry of Defence (R & D)
SHRI O. P. MALHOTRA	Public Works Department, Chandigarh Administration, Chandigarh
SHRI D. R. NARAHARI SHRI B. G. RAO (<i>Alternate</i>)	Central Building Research Institute (CSIR), Roorkee
SHRI T. K. NATRAJAN DR G. B. RAO	Central Road Research Institute (CSIR), New Delhi Indian Institute of Technology, New Delhi
DR K. K. GUPTA (<i>Alternate</i>) RESEARCH OFFICER (B & RRL)	Public Works Department, Government of Punjab, Chandigarh
SHRI K. R. SAXENA	Engineering Research Laboratories, Government of Andhra Pradesh, Hyderabad
SECRETARY DEPUTY SECRETARY (<i>Alternate</i>)	Central Board of Irrigation & Power, New Delhi
SHRI N. SVAGURU SHRI D. V. SIKKA (<i>Alternate</i>)	Roads Wing (Ministry of Shipping and Transport)
SHRI K. S. SRINIVASAN SHRI SUNIL BERRY (<i>Alternate</i>)	National Buildings Organization, New Delhi
SHRI N. SUBRAMANYAM	Karnataka Engineering Research Station, Krishna- rajasagar
SUPERINTENDING ENGINEER (P & DC) EXECUTIVE ENGINEER (SMRD) (<i>Alternate</i>)	Public Works Department, Government of Tamil Nadu, Madras
SHRI G. RAMAN, Director (Civ Engg)	Director General, ISI (<i>Ex-officio Member</i>)

Secretary

SHRI K. M. MATRUJ
Deputy Director (Civ Engg), ISI

The Site Exploration and Investigation for Foundation
Subcommittee, BDC 23 : 2

SHRI V. S. AGGARWAL	Central Building Research Institute, (CSIR), Roorkee
SHRI M. P. JAIN (<i>Alternate</i>) DR ALAM SINGH DEPUTY DIRECTOR RESEARCH (PE), RDSO ASSISTANT DIRECTOR RESEARCH (SOIL MECH), RDSO (<i>Alternate</i>)	University of Jodhpur, Jodhpur Ministry of Railways
DIRECTOR (CSMRS) DEPUTY DIRECTOR (CSMRS) (<i>Alternate</i>)	Central Water Commission, New Delhi
DIRECTOR, PWDRI	Public Works Department, Government of Uttar Pradesh, Lucknow

(Continued on page 18)

Indian Standard

CODE OF PRACTICE FOR SAMPLING OF SOILS BY THIN WALL SAMPLER WITH STATIONARY PISTON

0. FOREWORD

0.1 This Indian Standard was adopted by the Indian Standards Institution on 20 January 1982, after the draft finalized by the Soil Engineering and Rock Mechanics Sectional Committee had been approved by the Civil Engineering Division Council.

0.2 Undisturbed samples of soil are required for a number of soil tests, such as unconfined compression test, consolidation test, permeability test and triaxial compression test. It has been recognized that it is not practicable to obtain a truly undisturbed sample, but if certain procedures and precautions are observed, it is possible to get relatively undisturbed samples which may be considered sufficient keeping in view the nature of tests to be performed on these samples. This code deals with the method of obtaining such samples using this wall sampler with stationary piston, which are normally used for clay and silt formation.

0.3 For the purpose of deciding whether a particular requirement of this standard is complied with, the final value, observed or calculated, expressing the result of a test or analysis, shall be rounded off in accordance with IS : 2-1960*. The number of significant places retained in the rounded off value should be the same as that of the specified value in this standard.

1. SCOPE

1.1 This standard describes the method for obtaining undisturbed soil samples in fine grained soils for laboratory tests using thin wall sampler with stationary piston.

2. TERMINOLOGY

2.1 For the purpose of this standard, the definitions given in IS : 2809-1972† and the following shall apply.

*Rules for rounding off numerical values (*revised*).

†Glossary of terms and symbols relating to soil engineering (*first revision*).

2.1.1 Thin Wall Sampler with Stationary Piston — A sampler having a piston inside the thin wall sampling tube, in which during sampling, the position of the piston remains stationary and the sampling tube penetrates into the soil.

2.1.2 Undisturbed Sample — The sample taken with the minimum disturbance, maintaining the structure and engineering characteristics of soil as close as possible to its conditions *in situ*.

2.1.3 Area Ratio — The area ratio (A_r) represents the volume of soil displaced by the sampler in proportion to the volume of the soil sample and is calculated as follows:

$$A_r (\text{percent}) = \frac{D_e^3 - D_1^3}{D_1^2} \times 100$$

where D_e and D_1 are as shown in Fig. 1.

2.1.4 Inside Clearance — For reducing the friction between the soil sample and inside of the sampler, the inside diameter of the sampling tube is kept slightly bigger than the diameter at its cutting edge. The inside clearance (C_e) is defined as $C_e = \frac{D_1 - D}{D}$, where D_1 and D are as shown in Fig. 1.

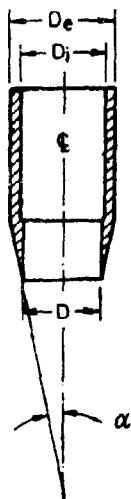

FIG. 1 DETAIL OF CUTTING EDGE

2.1.5 Angle of the cutting edge (α) is defined as the angle made by the outer side of the cutting edge with the centre line of the sampling tube, as shown in Fig. 1.

2.1.6 *Gross Recovery Ratio* — The ratio of the gross length of the sample obtained in the sampling tube to the length of the sampler penetrating into the soil stratum being sampled.

2.1.7 *Effective Length of the Sampling Tube* — The length of the empty sampling tube, left after deducting from its complete length those portions which are used for fixing it with the sampler head and for accommodating the piston in its uppermost position.

3. EQUIPMENT

3.1 *Boring Equipment* — Any equipment capable of making a bore-hole of required depth and diameter, without disturbing the soil which is to be sampled.

3.2 Sampler

3.2.1 The thin wall sampler with stationary piston consists of the sampling tube, sampler head and piston (Fig. 2). The sampling tube must be connected with the sampler head tightly so as to work as a single unit. The piston should slide smoothly in the sampling tube maintaining vacuum.

3.2.2 *Sampling Tube* — The sampling tube shall be a cold drawn seamless pipe made of stainless steel, brass or mild steel chrome plated having the following dimensions (see Fig. 3).

Diameter at the cutting edge, D	74 ± 0.5 mm	49.5 ± 0.5 mm
Inside diameter, D_1	75 ± 0.5 mm	50 ± 0.5 mm
Thickness for steel	1.5 ± 0.1 mm	1.5 ± 0.1 mm
Thickness for brass	2.0 ± 0.1 mm	1.5 ± 0.1 mm
Angle of cutting edge (α)	$10 \pm 1^\circ$	$10 \pm 1^\circ$
Thickness at the edge	0.2 ± 0.05 mm	0.2 ± 0.05 mm
Length, L	75 cm	60 cm

NOTE 1 — In the case of stiff clays or clays mixed with silt or fine sand, if necessary, the thickness of the sampling tube may be increased suitably with reference to Fig. 4, realizing that the increase in area ratio will increase the degree of disturbance of the soil sample.

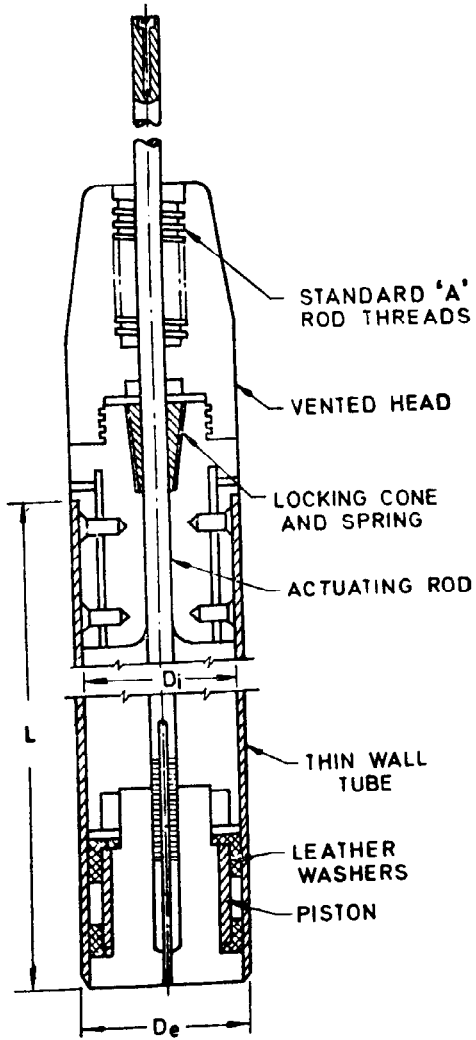

FIG. 2 STATIONARY PISTON SAMPLER

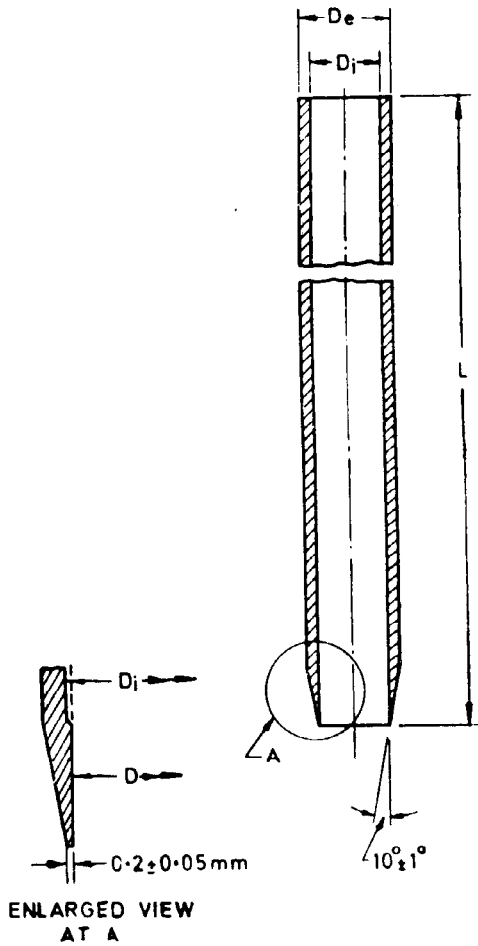

FIG. 3 DIMENSIONS OF SAMPLING TUBE.

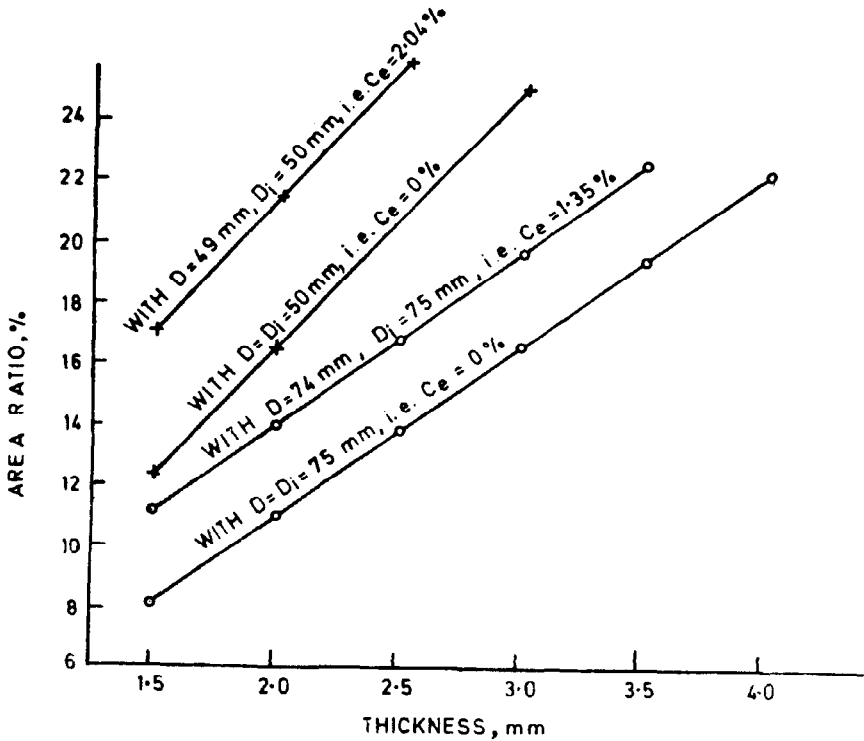

FIG. 4 VARIATION OF AREA RATIO WITH INSIDE CLEARANCE AND THICKNESS OF THE TUBE FOR SAMPLING TUBE OF INTERNAL DIAMETER OF 50 mm AND 75 mm

NOTE 2 — The degree of distortion of the sampling tube should be checked by measuring the maximum and minimum values of the outside diameter with the help of the vernier calliper along the length of the tube. The difference between the maximum and minimum values of the diameter should not exceed 1.5 mm.

3.2.3 Sampler Head — The sampler head is connected tightly with a drill rod at its top and with a sampling tube at its lower end. It is installed with a locking device to allow movement of the piston rod in one direction only and a drain hole through which water is pushed away by the piston.

3.2.4 Piston — The piston, consisting of the piston base, leather packing and piston rod, is connected with piston extension rod to its upper

end. The piston should be equipped with a ventilation arrangement to avoid build-up of negative pressure while the sampler is disconnected after sampling.

3.3 Rod

3.3.1 Drill Rod — The rod to transmit force to push down the sampler must be of any standard size having diameter not less than 40 mm.

3.3.2 Piston Extension Rod — In order to resist downward force applied to a piston while the sampling tube is being pushed into the ground, the piston rod, at its end outside the sampler, is connected to a steel member, known as piston extension (PE) rod, which has the same diameter as that of the piston rod. This rod is generally of 12 mm diameter and it operates inside the hollow drill rod. Joints in the piston extension rod are displaced about 15 cm from joints in the drill rods.

3.4 Locking of Piston Extension Rod — The mechanism shown in Fig. 5 or any other alternative may be used to provide a fixed support to the piston extension rod at the ground surface in order that the piston remains stationary when the sampling tube penetrates into the ground.

3.5 Apparatus to Push a Sampling Tube — An apparatus having a hydraulic jack or working with compressed air or a mechanical jacking is required to provide the necessary force to push a sampling tube, quickly and avoiding shocks, into the soil which is to be sampled.

4. PROCEDURES

4.1 Boring and Cleaning of a Borehole — The borehole shall be made to a desired depth using a suitable method and ensuring that the soil at the bottom of the hole remains undisturbed. Casing pipes and/or bentonite mud may be used to avoid collapse of borehole walls. The cuttings of soil from the borehole shall be removed before sampling.

4.2 Sampling

4.2.1 Inspection and Maintenance of Sampler — The sampler shall be thoroughly inspected before use with particular reference to loosening of components, functioning of piston rod lock device and distortion of sampling tubes. The damaged parts shall be repaired or replaced before using the sampler. The outside diameter of the sampling tube shall be measured at cross-sections at distances of 30, 40 and 80 cm from the edge of the tube. The maximum and minimum inside diameters of the tube shall also be checked.

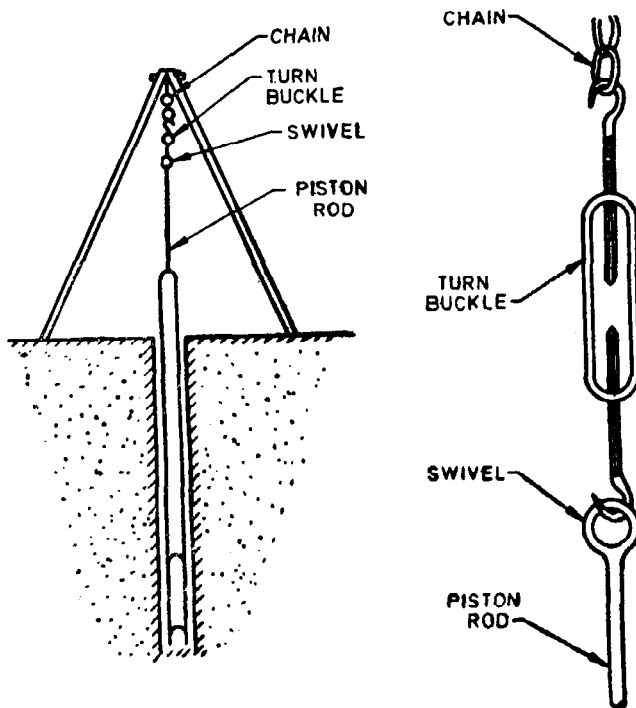

FIG. 5 SUPPORT OF THE PISTON EXTENSION ROD

4.2.2 Assembling of Sampler — In assembling the sampler, close the ventilation arrangement of the piston, and check if the backward and forward movements of the piston inside the sampling tube are without obstruction. Connect it to the sampler head tightly using screws. The assembled sampler shall be stored properly so as to protect the edge of the sampling tube against damage.

4.2.3 The depth of the bottom of the casing, if used below ground level, and water level in the borehole shall be noted.

4.2.4 Sampling shall be done as soon as possible after the clean-out operation and shall not be done after an interval, for example, where a borehole has been cleaned out and left overnight.

4.2.5 Lowering of the Sampler — While lowering the sampler into the borehole, the piston is kept at its lowest point thus closing the lower end of the sampler and preventing the entry of any foreign matter into the

sampler. The conical ball bearing catch, termed as piston rod lock in Fig. 2, prevents the piston rod from slipping downward with respect to the head of the sampler. To prevent upward movement of the piston as the sampler is lowered into the borehole, the piston rod has a short section of left-handed threads which engages a matching section of threads in the sampler head. By rotating the piston extension rod counter-clockwise, the rod is threaded into the sampler head and the piston is locked at the bottom of the sampler. The principle of this operation is explained by a simplified diagram in Fig. 6A. When the sampler reaches the bottom of the borehole, hold the drill rod by a rod holder to prevent sinking of the sampler.

4.2.6 Penetration of Sampling Tube — After lowering the sampler up to the desired depth in the borehole, give several clockwise turns to the piston extension rod, so that the piston gets released from the sampler. Now fix the piston extension rod with the stationary tower, as shown in Fig. 5, so that the piston remains stationary at the level of the bottom of the borehole. Ensure that the tower which supports the piston extension rods is rigid, as any downward movement of the piston at the time of penetration of the sampling tube will cause over-compression of the soil sample. Next, by an apparatus mentioned in 3.5, push the sampling tube into the soil for a length which is at least 90 percent of the effective sampling length of the tube, as explained in 2.1.7. The principle of this operation is explained by a simplified diagram in Fig. 6B. The sampler should be made to penetrate quickly by a continuous action without giving shock to it. The rate of penetration should be preferably 10 to 15 cm per second. In case the penetration has to be stopped midway, record its depth. In case the soil becomes stiffer midway of penetration and the sampler cannot be pushed any more, do not push it by force but terminate sampling at that depth and record the same.

Measure the sampling length which is equal to the extent of displacement of the drill rod with respect to the bench mark on the drill rig.

4.2.6.1 The following precautions during penetration of the sampling tubes may also be taken:

- a) There must not be any rotation of the sampling tube during downward movement and penetration.
- b) The total penetration should not exceed the net length of the sampler.

4.2.7 Lifting the Sampler — The sampler should be teared at its bottom by giving rotation before lifting it out, taking sufficient care not to give any shock to the sampler. After completion of the driving it is advisable

12

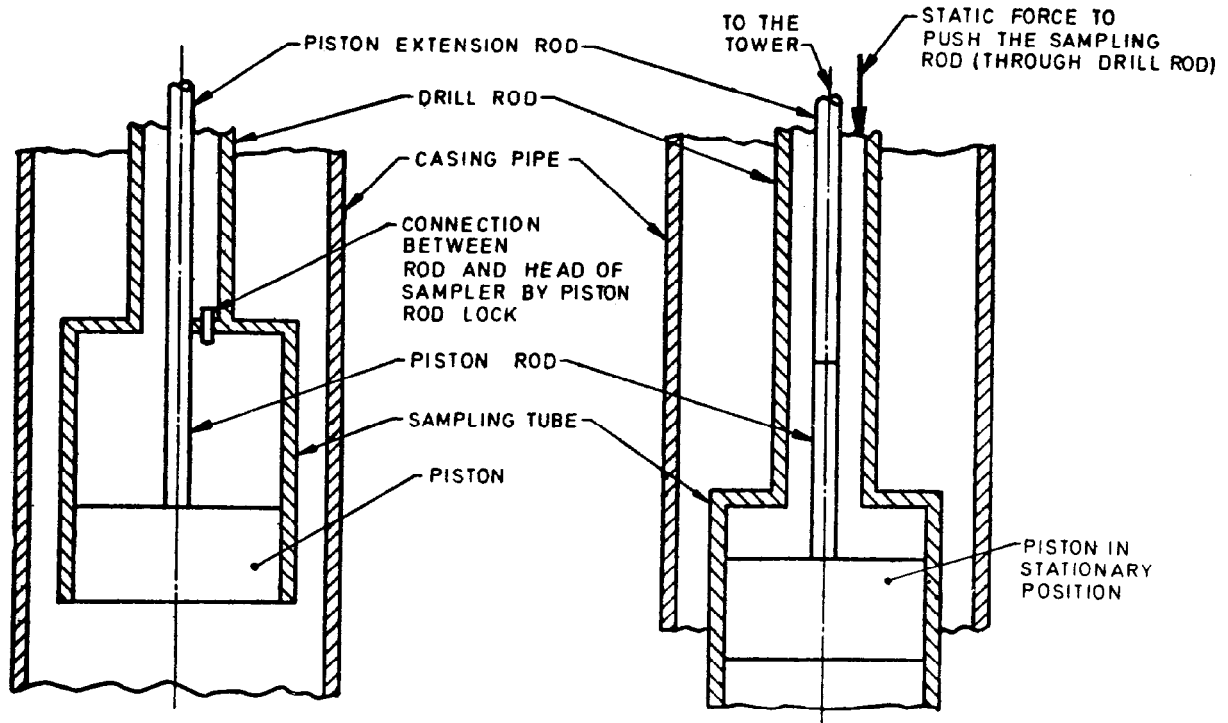

6A During Towing of Sampler

6B During Penetrating the Tube in Soil

FIG. 6 SIMPLIFIED DIAGRAM EXPLAINING PRINCIPLE OF OPERATION OF PISTON SAMPLER WITH STATIONARY PISTON

to wait for 10 to 20 minutes before starting the actual separation and withdrawal operation in order to allow full development of adhesion and friction between the sample and the sampling tube.

4.2.8 Disembarkment of the Sampler — The sampler shall be disconnected after confirming whether the soil sample is secured or partly dropped out. Before extracting the piston from the sampling tube, loosen the ventilation arrangement in the piston, and be careful not to deform the tube or to give shock to the sample.

NOTE 1 — In very loose sand and silty soil below water table, provision of core catcher made of spring leaves at the cutting edge of the sampler, may be necessary to avoid loss of sample while lifting it (see Fig. 7).

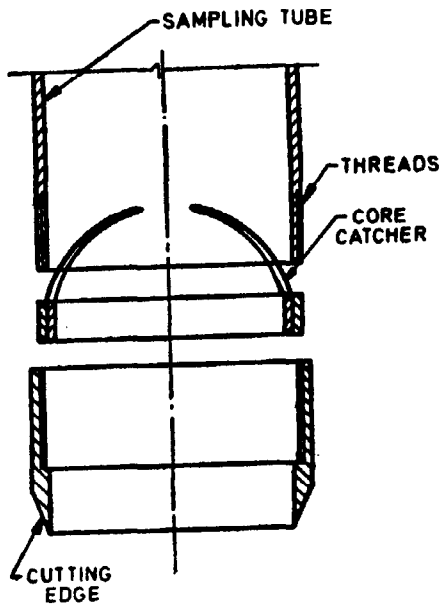

FIG. 7 FIXING CORE CATCHER ON THE INSIDE OF THE CUTTING EDGE OF THE SAMPLER

NOTE 2 — For minimising the disturbances further, the thin wall piston sampler should be operated hydraulically, for which the kit may be modified to suit the principle of operation explained in Fig. 8. It confers two advantages, namely, (a) needs only one set of rods, that is, ordinary drill rods, and (b) at full stroke, a hole in the position rod releases the soil pressure and avoids overdriving.

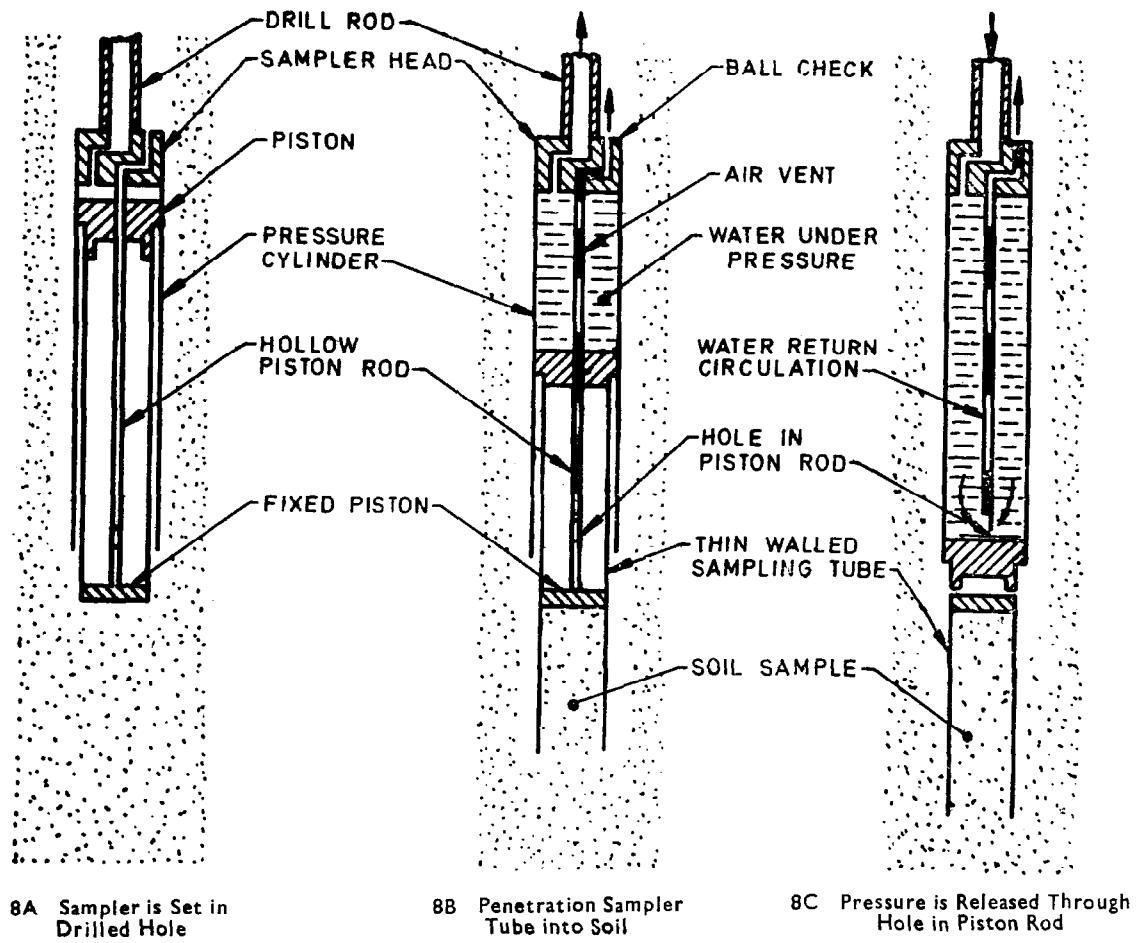

FIG. 8 DIAGRAMATIC SKETCH OF HYDRAULICALLY OPERATED PISTON ROD

4.2.9 Samples shall be taken by repeating the sampling procedures at every change in stratum or at intervals not more than 1.5 m, whichever is less. Samples may be taken at lesser intervals if specified or found necessary; when in between vane shear test is conducted the interval be increased to 3 m.

4.3 Field Observations — Water table information, including ground water level, elevations at which the drilling water was lost, or elevations at which water under excess pressure was encountered, should be recorded on the field logs. Particular mention should be made if these occurred at the time of sampling. Water levels before and after insertion of the casing, where used, should be measured. In sandy soils, the level should be determined as the casing is pulled and then measured at least 30 min after the casing is pulled; in silty soils at least 24 h after the casing is pulled; in clays no accurate water level determination is possible unless pervious seams are present. However, the 24 h level should also be recorded for clays. When drilling mud is used and the water level is desired, casing perforated at the lower end shall be lowered into the hole and the hole bailed down until all traces of drilling mud are removed from inside the casing. Ground water levels shall be determined after bailing at time intervals of 30 min and 24 h.

4.4 Preparation for Shipment

4.4.1 Upon removal of the sampling tube, measure the length of the sample obtained in the sampling tube and from the knowledge of the depth of penetration of the sampler, calculate and record the gross recovery ratio as given in 2.1.6. For a sample acceptable as undisturbed, the gross recovery ratio shall not be less than 95 percent.

4.4.2 Observe both ends of the sampler. If there are some soil fragments sedimented on the top of the sample, remove them and record it.

4.4.3 After reaming the soil at both ends of the tube up to the required extent, seal the ends of the sample with paraffin wax, etc, in order to prevent expansion or displacement of the sample or evaporation of moisture. Any wax that does not have appreciable shrinkage or does not permit evaporation of water from the sample shall be used. Micro-crystalline wax, if available, may be used in preference to paraffin wax. A mixture of paraffin wax and bees wax in the proportion 4 : 1 has also been found to be suitable. Thin discs of steel or brass that are slightly smaller than inside diameter of the tube are desirable for plugging both ends before sealing with wax. Suitable expanding packers may also be used.

The thickness of sealing shall not be less than 1 cm at the lower end of the sampler and not less than 3 cm at its top end.

4.4.4 Record the following on the outside of the sampling tube:

- a) Name of the project,
- b) Number of boring and that of sample,
- c) Depth of sampling,
- d) Date of sampling,
- e) Top and/or bottom end of the sample.

These particulars may preferably be given on a table indicated in IS : 1892-1980*.

4.4.5 When samples are temporarily stored at the work site, be careful not to subject them to serious change of temperature, as by direct exposure to sun.

4.5 Transportation

4.5.1 Sufficient care should be taken not to give impact or serious change of temperature to the samples during transportation.

4.5.2 When the samples are being stored in the laboratory, confirm sufficient sealing on both ends of the samples and then place them in appropriate lots confirming the particulars recorded on the sampling tube. Store the samples in a dark and humid room.

4.6 Extraction of Sample

4.6.1 The sample should be extracted in a humid room shaded from the sunshine. Remove the seal at both the ends and extrude the sample by a suitable extruder continuously, so that there is minimum disturbance to the sample. Also, avoid any cause of bending or breakage of the sample by its own weight.

4.6.2 Examine the extruded sample very closely and locate the relatively disturbed and undisturbed portions of the sample so as to select an appropriate part of the sample which will suit the permissible degree of disturbance of sample for the desired test.

5. REPORT

5.1 All data obtained during the boring and sampling operations shall be recorded in the field and shall include the following:

- a) Job identification;
- b) Date of boring — start, finish;
- c) Boring number and co-ordinates, if available;

*Code of practice for subsurface investigations for foundations (*first revision*).

- d) Surface elevation, if available;
- e) Drilling method;
- f) Sample number and depth;
- g) Method of advancing sampler, penetration and recovery ratio, and pressure required for pushing the sampler, if available;
- h) Type and size of sampler;
- j) Depth to water surface, to loss of water, to artesian head, and times at which readings were made;
- k) Size of casing, depth of cased hole;
- m) Description of soil based on examination of soil removed from the ends of tubes;
- n) Thickness of layer;
- p) Weather conditions; and
- q) Other observations and remarks.

These observations shall be recorded in a suitable proforma. A recommended proforma is given in Appendix A of IS : 2132-1972*.

*Code of practice for thin-walled tube sampling of soils (first revision).

(Continued from page 2)

<i>Members</i>	<i>Representing</i>
EXECUTIVE ENGINEER (DESIGN) V	Central Public Works Department, New Delhi
EXECUTIVE ENGINEER (SMRD)	Public Works Department, Government of Tamil Nadu, Madras
EXECUTIVE ENGINEER (CD) (<i>Alternate</i>)	
SHRI M. D. NAIR	Associated Instruments Manufacturers (India) Private Ltd, New Delhi
PROF T. S. NAGARAJ (<i>Alternate</i>)	
SHRI T. K. NATARAJAN	Central Road Research Institute (CSIR), New Delhi
LT-COL K. M. S. SAHASI	Engineer-in-Chief's Branch, Army Headquarters (Ministry of Defence)
SHRI A. K. CHATURVEDI (<i>Alternate</i>)	
SHRI S. K. SHOME	Geological Survey of India, Calcutta
SHRI P. N. MEHTA (<i>Alternate</i>)	
SHRI N. SIVAGURU	Roads Wing, Ministry of Transport
SHRI P. K. THOMAS (<i>Alternate</i>)	
SUPERINTENDING ENGINEER (IP), NAGPUR	Irrigation Department, Government of Maharashtra, Bombay

BUREAU OF INDIAN STANDARDS

Headquarters:

Manak Bhavan, 9 Bahadur Shah Zafar Marg, NEW DELHI 110002

Telephones: 323 0131, 323 3375, 323 9402

Fax : 91 11 3234062, 91 11 3239399, 91 11 3239382

Telegrams : Manaksanstha
(Common to all Offices)

Central Laboratory :

Plot No. 20/9, Site IV, Sahibabad Industrial Area, Sahibabad 201010 Telephone 8-77 00 32

Regional Offices:

Central : Manak Bhavan, 9 Bahadur Shah Zafar Marg, NEW DELHI 110002 323 76 17

*Eastern : 1/14 CIT Scheme VII M, V.I.P. Road, Maniktola, CALCUTTA 700054 337 86 62

Northern : SCO 335-336, Sector 34-A, CHANDIGARH 160022 60 38 43

Southern : C.I.T. Campus, IV Cross Road, CHENNAI 600113 235 23 15

†Western : Manakalaya, E9, Behind Marol Telephone Exchange, Andheri (East), MUMBAI 400093 832 92 95

Branch Offices::

'Pushpak', Nurmohamed Shaikh Marg, Khanpur, AHMEDABAD 380001 550 13 48

‡Peenya Industrial Area, 1st Stage, Bangalore-Tumkur Road, BANGALORE 560058 839 49 55

Gangotri Complex, 5th Floor, Bhadbhada Road, T.T. Nagar, BHOPAL 462003 55 40 21

Plot No. 62-63, Unit VI, Ganga Nagar, BHUBANESHWAR 751001 40 36 27

Kalaikathir Buildings, 670 Avinashi Road, COIMBATORE 641037 21 01 41

Plot No. 43, Sector 16 A, Mathura Road, FARIDABAD 121001 8-28 88 01

Savitri Complex, 116 G.T. Road, GHAZIABAD 201001 8-71 19 96

53/5 Ward No.29, R.G. Barua Road, 5th By-lane, GUWAHATI 781003 54 11 37

5-8-56C, L.N. Gupta Marg, Nampally Station Road, HYDERABAD 500001 20 10 83

E-52, Chitaranjan Marg, C-Scheme, JAIPUR 302001 37 29 25

117/418 B, Sarvodaya Nagar, KANPUR 208005 21 68 76

Seth Bhawan, 2nd Floor, Behind Leela Cinema, Naval Kishore Road, LUCKNOW 226001 23 89 23

NIT Building, Second Floor, Gokulpat Market, NAGPUR 440010 52 51 71

Patiputra Industrial Estate, PATNA 800013 26 23 05

Institution of Engineers (India) Building 1332 Shivaji Nagar, PUNE 411005 32 36 35

T.C. No. 14/1421, University P. O. Palayam, THIRUVANANTHAPURAM 695034 6 21 17

*Sales Office is at 5 Chowringhee Approach, P.O. Princep Street, CALCUTTA 700072 27 10 85

†Sales Office is at Novelty Chambers, Grant Road, MUMBAI 400007 309 65 28

‡Sales Office is at 'F' Block, Unity Building, Narashimaraja Square, BANGALORE 560002 222 39 71