

*Indian Standard*

SPECIFICATION FOR COMPACTION MOULD  
ASSEMBLY FOR LIGHT AND HEAVY  
COMPACTION TEST FOR SOILS

UDC 624.131.378

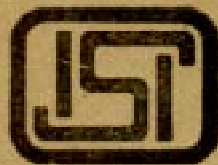

© *Copyright* 1982

**INDIAN STANDARDS INSTITUTION**  
MANAK BHAVAN, 9 BAHADUR SHAH ZAFAR MARG  
NEW DELHI 110002

# Indian Standard

## SPECIFICATION FOR COMPACTION MOULD ASSEMBLY FOR LIGHT AND HEAVY COMPACTION TEST FOR SOILS

Soil Engineering and Rock Mechanics Sectional Committee, BDC 23

<i>Chairman</i>	<i>Representing</i>
DR JAGDISH NARAIN	University of Roorkee, Roorkee
<i>Members</i>	
ADDITIONAL DIRECTOR, IRI	Irrigation Department, Government of Bihar, Patna
ADDITIONAL DIRECTOR RESEARCH ( F. E. ), RDSO	RE- Ministry of Railways
DEPUTY DIRECTOR RESEARCH ( SOIL-MECH ), RDSO ( <i>Alternate</i> )	
SHRI P. D. AGARWAL	Public Works Department, Government of Uttar Pradesh, Lucknow
DR B. L. DHAWAN ( <i>Alternate</i> )	
PROF ALAM SINGH	University of Jodhpur, Jodhpur
COL AVTAR SINGH	Engineer-in-Chief's Branch, Army Headquarters
LT-COL V. K. KANITKAR ( <i>Alternate</i> )	
CHIEF ENGINEER ( D & R )	Irrigation Department, Government of Punjab, Chandigarh
DR G. S. DHILLON ( <i>Alternate</i> )	
SHRI M. C. DANDAVATE	The Concrete Association of India, Bombay
SHRI N. C. DUGGAL ( <i>Alternate</i> )	
SHRI A. G. DASTIDAR	In personal capacity ( 5 Hungerford Street, 12/1 Hungerford Court, Calcutta-700017 )
DR G. S. DHILLON	Indian Geotechnical Society, New Delhi
DIRECTOR, IRI	Irrigation Department, Government of Uttar Pradesh, Roorkee
SHRI A. H. DIVANJI	Asia Foundations and Construction ( P ) Ltd, Bombay
SHRI A. N. JANGLE ( <i>Alternate</i> )	
DR GOPAL RANJAN	University of Roorkee, Roorkee
DR GOPAL RANJAN	Institution of Engineers ( India ), Calcutta
SHRI S. GUPTA	Cemindia Co Ltd, Bombay
SHRI N. V. DE SOUSA ( <i>Alternate</i> )	
SHRI G. S. JAIN	G. S. Jain & Associates, Roorkee
SHRI VIJAY K. JAIN ( <i>Alternate</i> )	

( Continued on page 2 )

© Copyright 1982

INDIAN STANDARDS INSTITUTION

This publication is protected under the *Indian Copyright Act* ( XIV of 1957 ) and reproduction in whole or in part by any means except with written permission of the publisher shall be deemed to be an infringement of copyright under the said Act.

( Continued from page 1 )

<i>Members</i>	<i>Representing</i>
SHRI A. B. JOSHI DEPUTY DIRECTOR ( CSMRS ) ( Alternate )	Ministry of Irrigation
COL M. V. KAYERKAR SHRI V. B. GHORFADE ( Alternate )	Ministry of Defence ( R & D )
SHRI O. P. MALHOTRA	Public Works Department, Chandigarh Administration, Chandigarh
SHRI D. R. NARAHARI	Central Building Research Institute ( CSIR ), Roorkee
SHRI B. G. RAO ( Alternate )	
SHRI T. K. NATRAJAN	Central Road Research Institute ( CSIR ), New Delhi
DR G. V. RAO	Indian Institute of Technology, New Delhi
DR K. K. GUPTA ( Alternate )	
RESEARCH OFFICER ( B & RRL )	Public Works Department, Government of Punjab, Chandigarh
SHRI K. R. SAXENA	Engineering Research Laboratories, Government of Andhra Pradesh, Hyderabad
SECRETARY	Central Board of Irrigation & Power, New Delhi
DEPUTY SECRETARY ( Alternate )	
SHRI N. SIVAGURU	Roads Wing ( Ministry of Shipping and Transport )
SHRI D. V. SIKKA ( Alternate )	
SHRI K. S. SRINIVASAN	National Buildings Organization, New Delhi
SHRI SUNIL BERRY ( Alternate )	
SHRI N. SUBRAMANYAM	Karnataka Engineering Research Station, Krishnarajasagar
SUPERINTENDING ENGINEER ( P & D )	PWD, Government of Tamil Nadu, Madras
EXECUTIVE ENGINEER ( SMRD ) ( Alternate )	
SHRI G. RAMAN, Director ( Civ Engg )	Director General, ISI ( <i>Ex-officio Member</i> )
	<i>Secretary</i>
	SHRI K. M. MATHUR Deputy Director ( Civ Engg ), ISI

### Soil Testing Instruments and Equipment Subcommittee, BDC 23 : 6

	<i>Convener</i>
SHRI H. C. VERMA	Associated Instrument Manufacturers ( I ) Pvt Ltd, New Delhi
	<i>Members</i>
SHRI M. D. NAIR ( Alternate to Shri H. C. Verma )	
DEPUTY DIRECTOR RESEARCH ( SOIL MECH ), RDSO	Ministry of Railways
DIRECTOR ( CSMRS )	Ministry of Irrigation
DEPUTY DIRECTOR ( CSMRS ) ( Alternate )	

( Continued on page 11 )

# *Indian Standard*

## SPECIFICATION FOR COMPACTION MOULD ASSEMBLY FOR LIGHT AND HEAVY COMPACTION TEST FOR SOILS

### 0. FOREWORD

**0.1** This Indian Standard was adopted by the Indian Standards Institution on 20 January 1982, after the draft finalized by the Soil Engineering and Rock Mechanics Sectional Committee had been approved by the Civil Engineering Division Council.

**0.2** The Indian Standards Institution has already published a series of standards on methods of testing soils. It has been recognized that reliable and intercomparable test results can be obtained only with standard testing equipment capable of giving the desired level of accuracy. The Sectional Committee has, therefore, decided to bring out a series of specifications covering the requirements of equipment used for testing soils to encourage its development and manufacture in the country.

**0.3** The equipment covered in this standard is used for determination of water content: dry density relation as covered in IS : 2720 ( Part VII )-1980\* and IS : 2720 ( Part VIII )-1974†.

**0.4** For the purpose of deciding whether a particular requirement of this standard is complied with, the final value, observed or calculated, expressing the result of a test or analysis, shall be rounded off in accordance with IS : 2-1960‡. The number of significant places retained in the rounded off value should be the same as that of the specified value in this standard.

---

### 1. SCOPE

**1.1** This standard covers the requirements of compaction mould assembly used for determination of water content: dry density relation of soils using light and heavy compaction.

\*Methods of test for soils: Part VII Determination of water content: dry density relation using light compaction ( *second revision* ).

†Methods of test for soils: Part VIII Determination of water content: dry density relation using heavy compaction ( *first revision* ).

‡Rules for rounding off numerical values ( *revised* ).

## 2. MATERIALS

2.1 The materials of construction of the different component parts of compaction mould assembly shall be as given in Table 1.

**TABLE 1 MATERIALS OF CONSTRUCTION OF DIFFERENT COMPONENT PARTS OF COMPACTION MOULD ASSEMBLY**

PART	MATERIAL	SPECIFIC REQUIREMENTS, IF ANY	REFERENCE TO INDIAN STANDARD
Mould, Collar, Base plate	{ a) Copper alloy	—	IS : 318-1962*
	{ b) Brass	—	IS : 292-1961†
	{ c) Mild steel‡	Cadmium plated	IS : 513-1973§
Stay rods	Mild steel	Chromium plated	—
Wing nuts	Cast steel/Forged steel	Cadmium plated	—

\*Specification for leaded tin bronze ingots and castings ( *revised* ).

†Specification for brass ingots and castings ( *revised* ).

‡For short term use.

§Specification for cold rolled carbon steel sheets ( *second revision* ).

## 3. TYPES AND DIMENSIONS

3.1 The compaction mould assembly shall be of two types ( Types 1 and 2 ). Dimensions of component parts of compaction mould assembly shall be as detailed in Fig. 1 to Fig. 6. Except where tolerances are specifically mentioned against the dimensions, all dimensions shall be taken as nominal dimensions and tolerances as given in IS : 2102-1969\* shall apply.

## 4. CONSTRUCTION

**4.1 Compaction Mould** — The compaction mould shall be of two types as detailed in Fig. 2. It shall be cylindrical in shape and finished smooth inside. The mould shall have two eyes either cast integral with the body or welded. It shall have suitable seatings at the top end for positioning the collar.

**4.2 Collar** — The collar shall be made from the same material as that of the mould. It shall be made as detailed in Fig. 3. The collar shall be cylindrical in shape and finished smooth inside. Two eyes either cast or welded to the collar to secure it with the mould and base plate shall be provided. It shall have a suitable seating at the lower end for sitting flush with the mould.

\*Allowable deviations for dimensions without specified tolerances ( *first revision* ).

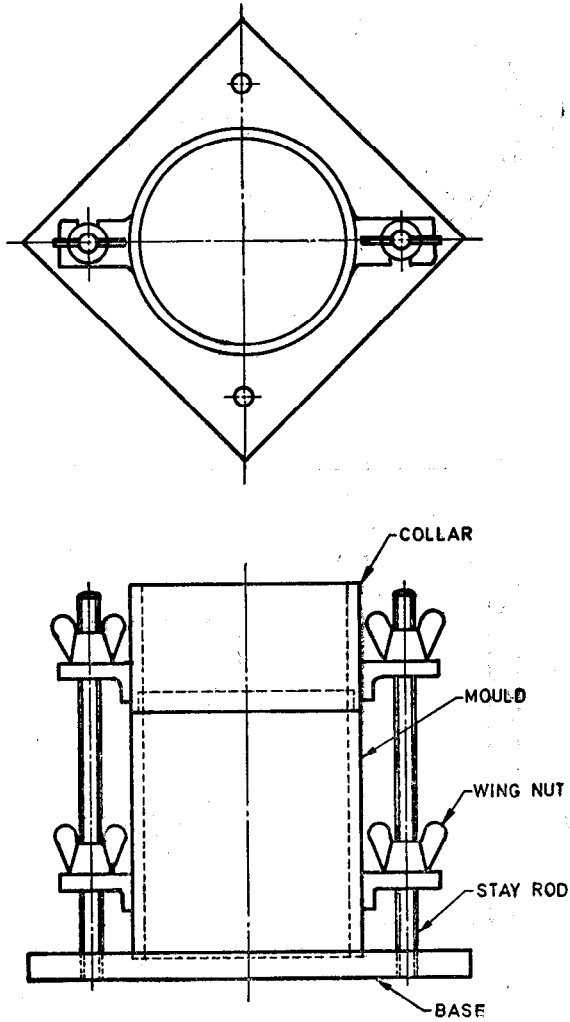
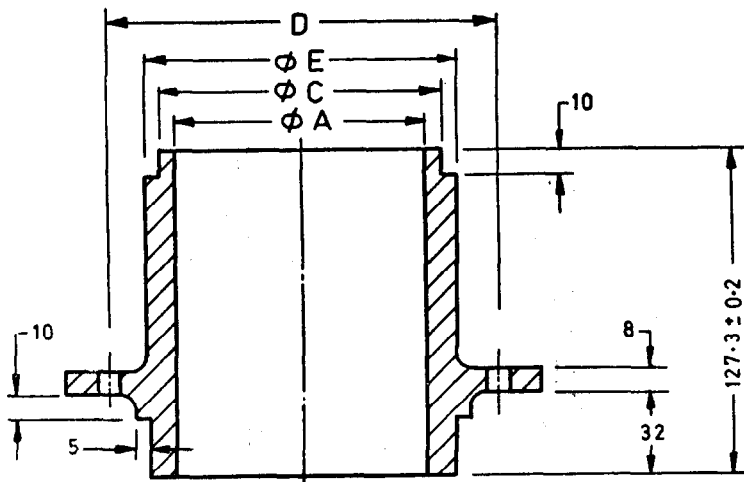
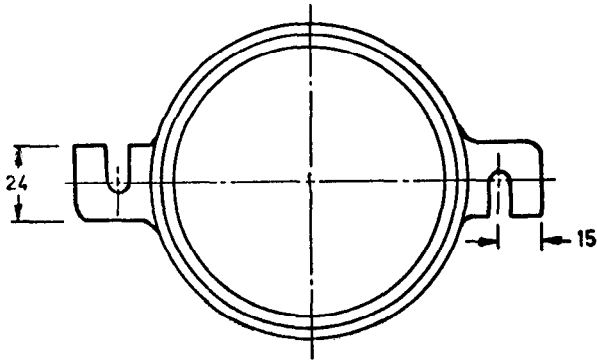

FIG. 1 ASSEMBLY



TYPE	A mm	C mm	D mm	E mm
1	$100 \pm 0.4$	106	150	112
2	$150 \pm 0.4$	156	200	162

All dimensions in millimetres.

FIG. 2 MOULD

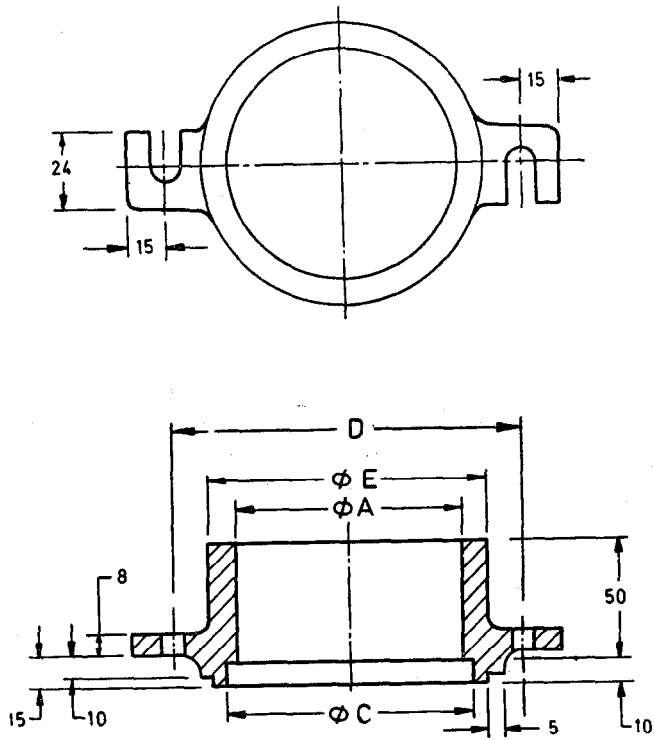

TYPE OF MOULD	A mm	C mm	D mm	E mm
1	$100 \pm 0.4$	106	150	112
2	$150 \pm 0.4$	156	200	162

All dimensions in millimetres.

FIG. 3 COLLAR



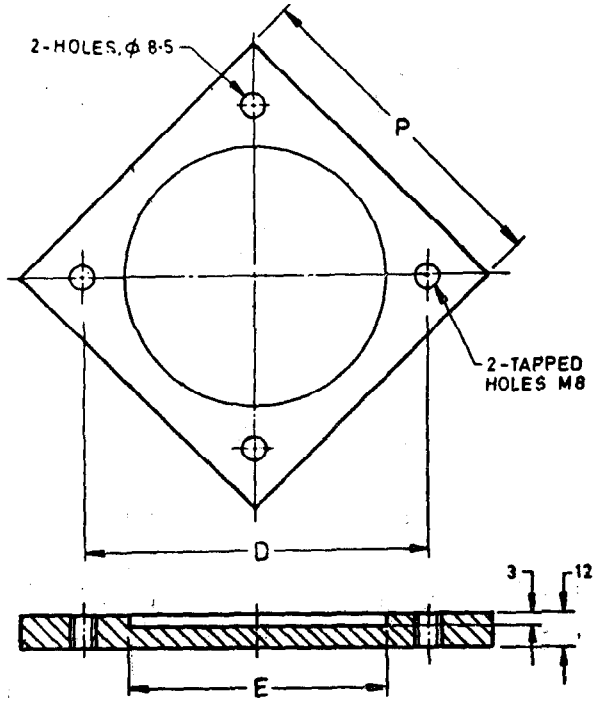

TYPE OF MOULD	<i>D</i> mm	<i>E</i> mm	<i>P</i> mm
1	150	112.5	150
2	200	162.5	200

All dimensions in millimetres.

FIG. 4 BASE PLATE ( SQUARE )

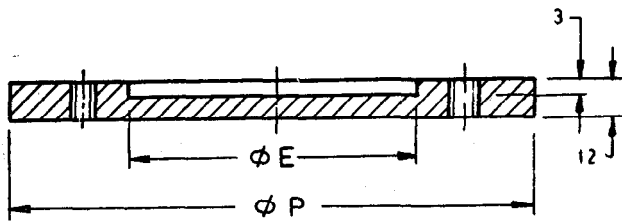
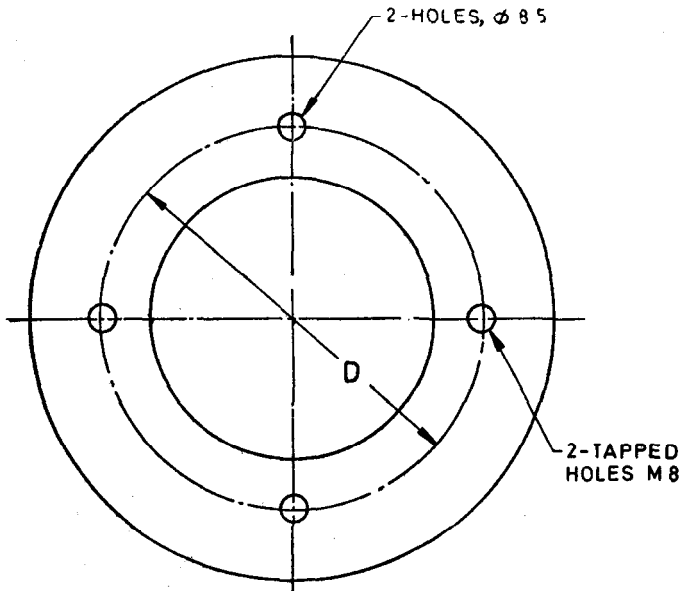

TYPE OF MOULD	$D$ mm	$E$ mm	$P$ mm
1	150	120.5	180
2	200	170.5	230

All dimensions in millimetres.

FIG. 5 BASE PLATE ( CIRCULAR )

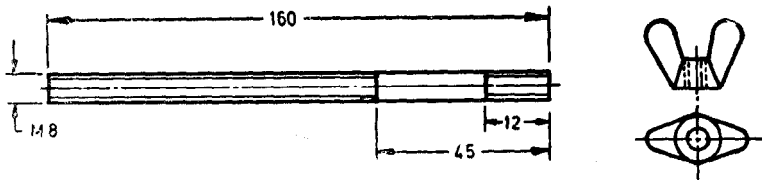

6A Stay Rod

6B Wing Nut

All dimensions in millimetres.

FIG. 6 STAY ROD AND WING NUT

**4.3 Base Plate** — The base plate shall be made from the same material as that of the mould. The base plate shall have a seating 3 mm deep on top face for proper seating of mould. It shall be square in shape and shall be as detailed in Fig. 4. Alternatively, the base plate shall be made circular in shape as detailed in Fig. 5. It shall have two tapped and two plain holes. The tapped holes across the corners or diameter shall be used for fixing the stay rods ( as shown in Fig. 6A ) and the plain holes shall be used to fix the base plate to the base of an automatic compactor. The stay rods shall be fixed to suit the eyes on the mould and collar and four wing nuts ( as shown in Fig. 6B ) shall be used to tighten the mould and collar with the base plate.

## 5. MARKING

**5.1** The following information shall be clearly and indelibly marked on each part of equipment:

- a) Name of the manufacturer or his registered trade-mark;
- b) Type of material used; and
- c) Date of manufacture.

**5.1.1** The equipment may also be marked with the ISI Certification Mark.

**NOTE** — The use of the ISI Certification Mark is governed by the provisions of the Indian Standards Institution ( Certification Marks ) Act and the Rules and Regulations made thereunder. The ISI Mark on products covered by an Indian Standard conveys the assurance that they have been produced to comply with the requirements of that standard under a well-defined system of inspection, testing and quality control which is devised and supervised by ISI and operated by the producer. ISI marked products are also continuously checked by ISI for conformity to that standard as a further safeguard. Details of conditions under which a licence for the use of the ISI Certification Mark may be granted to manufacturers or processors, may be obtained from the Indian Standards Institution.

( Continued from page 2 )

<i>Members</i>	<i>Representing</i>
SHRI H. K. GUHA	Geologists' Syndicate Pvt Ltd, Calcutta
SHRI A. BHATTACHARYA ( <i>Alternate</i> )	
SHRI A. K. GUPTA	Saraswati Engineering Agency, Roorkee
SHRI RAKESH GOEL ( <i>Alternate</i> )	
SHRI S. K. GUPTA	Ministry of Defence ( ENC's Branch, Army Headquarters )
DR S. C. HANDA	University of Roorkee, Roorkee
DR B. R. MALHOTRA	Central Road Research Institute ( CSIR ), New Delhi
SHRI D. S. PATHANIA	Central Scientific Instruments Organization ( CSIR ), Chandigarh
SHRI Y. C. SOOD ( <i>Alternate</i> )	
DR T. RAMAMURTHY	Indian Institute of Technology, Delhi
SHRI RESHAM SINGH	Hydraulic & Engineering Instruments Company, New Delhi
SHRI JATINDER SINGH ( <i>Alternate</i> )	
SHRI S. VENKATESAN	Central Building Research Institute ( CSIR ), Roorkee
SHRI M. R. SONEJA ( <i>Alternate</i> )	

# INTERNATIONAL SYSTEM OF UNITS (SI UNITS)

## Base Units

<i>Quantity</i>	<i>Unit</i>	<i>Symbol</i>
Length	metre	m
Mass	kilogram	kg
Time	second	s
Electric current	ampere	A
Thermodynamic temperature	kelvin	K
Luminous intensity	candela	cd
Amount of substance	mol	mole

## Supplementary Units

<i>Quantity</i>	<i>Unit</i>	<i>Symbol</i>
Plane angle	radian	rad
Solid angle	steradian	sr

## Derived Units

<i>Quantity</i>	<i>Unit</i>	<i>Symbol</i>	<i>Definition</i>
Force	newton	N	1 N = 1 kg.m/s <sup>2</sup>
Energy	joule	J	1 J = 1 N.m
Power	watt	W	1 W = 1 J/s
Flux	weber	Wb	1 Wb = 1 V.s
Flux density	tesla	T	1 T = 1 Wb/m <sup>2</sup>
Frequency	hertz	Hz	1 Hz = 1 c/s (s <sup>-1</sup> )
Electric conductance	siemens	S	1 S = 1 A/V
Electromotive force	volt	V	1 V = 1 W/A
Pressure, stress	pascal	Pa	1 Pa = 1 N/m <sup>2</sup>